

Electronic Theses and Dissertations, 2004-2019

2009

Providing A Better Understanding For The Motorist Behavior Towards Signal Change

Noor Elmitiny
University of Central Florida

 Part of the [Civil Engineering Commons](#)
Find similar works at: <https://stars.library.ucf.edu/etd>
University of Central Florida Libraries <http://library.ucf.edu>

This Doctoral Dissertation (Open Access) is brought to you for free and open access by STARS. It has been accepted for inclusion in Electronic Theses and Dissertations, 2004-2019 by an authorized administrator of STARS. For more information, please contact STARS@ucf.edu.

STARS Citation

Elmitiny, Noor, "Providing A Better Understanding For The Motorist Behavior Towards Signal Change" (2009). *Electronic Theses and Dissertations, 2004-2019*. 3848.
<https://stars.library.ucf.edu/etd/3848>

PROVIDING A BETTER UNDERSTANDING FOR THE MOTORIST BEHAVIOR TOWARDS SIGNAL CHANGE

by

NOOR ELMITINY
B. S. Cairo University Faculty of Engineering
M.S.C.E (Transportation) University of Central Florida

A dissertation submitted in partial fulfillment of the requirements
for the Degree of Doctor of Philosophy
in the Department of Civil, Environmental and Construction Engineering
in the College of Engineering and Computer Science
at the University of Central Florida
Orlando, Florida

Summer Term
2009

Major Professor: Essam Radwan

© 2009 Noor Elmitiny

ABSTRACT

This research explores the red light running phenomena and offer a better understanding of the factors associated with it. The red light running is a type of traffic violation that can lead to angle crash and the most common counter measure is installing a red light running cameras. Red light running cameras some time can reduce the rates of red light running but because of the increased worry of the public towards crossing the intersection it can cause an increase in rear end crashes. Also the public opinion of the red light running cameras is that they are a revenue generator for the local counties and not a concern of public safety. Further more, they consider this type of enforcement as violation of privacy.

There was two ways to collect the data needed for the research. One way is through a tripod cameras setup temporarily placed at the intersection. This setup can collect individual vehicles caught in the change phase with specific information about their reactions and conditions. This required extensive manual analysis for the recorded videos plus data could not be collected during adverse weather conditions. The second way was using traffic monitoring cameras permanently located at the site to collect red light running information and the simultaneous traffic conditions. This system offered more extensive information since the cameras monitor the traffic 24/7 collecting data directly. On the other hand this system lacked the ability to identify the circumstances associated with individual red light running incidents. The research team finally decided to use the two methods to study the red light running phenomena aiming to combine the benefits of the two systems.

During the research the team conducted an experiment to test a red light running countermeasure in the field and evaluate the public reaction and usage of this countermeasure. The marking was previously tested in a driving simulator and proved to be successful in helping the drivers make better stop/go decisions thus reducing red light running rates without increasing the rear-end crashes.

The experiment was divided into three phases; before marking installation called “before”, after marking installation called “after”, and following a media campaign designed to inform the public about the use of the marking the third phase called “after media”

The behavior study that aimed at analyzing the motorist reactions toward the signal change interval identified factors which contributed to red light running. There important factors were: distance from the stop bar, speed of traffic, leading or following in the traffic, vehicle type. It was found that a driver is more likely to run red light following another vehicle in the intersection. Also the speeding vehicles can clear the intersection faster thus got less involved in red light running violations.

The proposed “Signal Ahead” marking was found to have a very good potential as a red light running counter measure. The red light running rates in the test intersection dropped from 53 RLR/hr/1000veh for the “before” phase, to 24 RLR/hr/1000veh for the “after media” phase. The marking after media analysis period found that the marking can help

the driver make stop/go decision as the dilemma zone decreased by 50 ft between the “before” and the “after media” periods.

Analysis of the traffic condition associated with the red light running it revealed that relation between the traffic conditions and the red light running is non-linear, with some interactions between factors. The most important factors included in the model were: traffic volume, average speed of traffic, the percentage of green time, the percentage of heavy vehicles, the interaction between traffic volume and percentage of heavy vehicles.

The most interesting finding was the interaction between the volume and the percent of heavy vehicles. As the volume increased the effect of the heavy vehicles reversed from reducing the red light running to increasing the red light. This finding may be attributed to the sight blocking that happens when a driver of a passenger car follows a larger heavy vehicle, and can be also explained by the potential frustration experienced by the motorist resulting from driving behind a bigger vehicle.

ACKNOWLEDGMENTS

I would like to extend my sincere thanks and gratitude to my advisor Dr. Essam Radwan, for being the most supportive advisor and mentor. When ever I was in need of help he had a listening ear and welcoming hart, in addition to his guiding opinion and supportiveness, his support always drove me to try to get better and reach higher standards. I am proud to join the long line of his successful students. I would also like to extend my thanks to my valued professors and committee members Dr. Amr Oloufa, Dr. Hitham Al-Deek, Dr. Mohamed A. Abdel Aty, and Dr. Nizam Uddin. They taught me how to be a productive person as well as how to be a good scholar.

To my beloved family; my father, my sisters and my wife, their continuous support and absolute faith helped me to get trough the hardest times, thank you.

I would like to thank all my colleagues, friend and professors at the University of Central Florida. Any person would be blessed to have such company in his life.

TABLE of CONTENTS

LIST OF FIGURES	ix
LIST OF TABLES	xi
CHAPTER ONE : INTRODUCTION	1
1.1 Red Light Running Definition	1
1.2 Traffic Facts Related to Red Light Running in the U.S.....	2
1.3 Red Light Running Problem	3
CHAPTER TWO: LITERATURE REVIEW.....	5
2.1 Safety Issues Involved in Yellow Signal Change	5
2.2 Contributing Factors and Characteristics of Red Light Violation	8
2.3 Research Modeling Red Light Running Behavior and Affecting Factors	11
2.4 Characteristics of Red Light Violators	12
2.5 Countermeasures to Decrease Red Light Running	15
2.5.1 Red-light camera	15
2.5.2 Re-timing of Traffic Signal Change Intervals	17
2.5.3 Advance Information of Yellow Change.....	17
2.6 Dilemma Zone Background in Research	20
CHAPTER THREE: ISSUES RELATED TO RED LIGHT CAMERAS ENFORCEMENT SYSTEM	22
3.1 How does the System Work.....	22
3.2 System Effectiveness (Implementation Experience)	23
3.3 System Political Acceptability and Legal Issues	26
3.4 Need for Better Understanding and Implementation	29
CHAPTER FOUR: RESEARCH OBJECTIVES AND METHODOLOGY	31
4.1 Research Objectives.....	33
4.2 Research Tasks.....	34
4.3 Behavior Study for the Proposed Marking	35
4.4 Before and After Study to Evaluate the Effectiveness of the Marking.....	36
4.4.1 Concept of the Marking	37
4.4.2 Experiment Description	37
4.5 The Marking Design Details.....	40
4.6 Relation Between the Marking and the Dilemma Zone.....	44
CHAPTER FIVE: RESEARCH PHASES	48
5.1 Before.....	48
5.2 After Without Media.....	49
5.3 Media Campaign.....	49
5.3.1 University Media Coverage	50
5.4 After With Media.....	53
CHAPTER SIX: METHODS OF DATA COLLECTION	54
6.1 Behavior Study for the Proposed Marking Data Collection	54
6.1.1 Data Collection Using Video-Based System	54
6.1.2 Extracting Data from Videos	56
6.2 Before and After Study to Evaluate the Effectiveness of the Marking.....	60
6.2.1 Traffic Monitoring Camera.....	60
6.2.2 Camera Installation	61

6.2.3	Pilot Observation of Red-light Running	63
6.2.4	Data Output from the Camera System	65
CHAPTER SEVEN: RED LIGHT RUNNING BEHAVIOR DATA ANALYSIS		67
7.1	Data Primary Analysis	67
7.2	Driver Behavior Observation Results and Data Analysis	70
7.2.1	Operating Speed	70
7.2.2	Stop/Go Decision and RLR	72
7.2.3	Tree-based Classification Analysis of Stop/Go Decision and RLR	74
7.2.4	Stop/Go decision Model	76
7.2.5	RLR Model	79
7.2.6	Yellow-entry Time	82
CHAPTER EIGHT: MARKING EFFECTIVENESS ANALYSIS		85
8.1	Effectiveness of the Media Campaign	85
8.2	Effect of the Marking on Driver Behavior	86
8.2.1	Effect of the Marking on Dilemma Zone	88
8.3	Before-After Analysis of Marking Effectiveness Traffic Monitoring Cameras’ Data	90
8.3.1	Red-light Running Trends	91
CHAPTER NINE: TRAFFIC MONITORING CAMERAS’ DATA ANALYSIS		97
9.1	Variables Description	97
9.2	General Data Trends Analysis	98
9.2.1	Change of Red-light Running over the Days of the Week	98
9.2.2	Change of red light running between week ends and working days	100
9.3	Examined Methods of Analysis	102
9.3.1	Linear Regression Model	103
9.3.2	Classification Tree Model	104
9.3.3	Augmented Multivariate Adaptive Regression Splines (MARS)	109
CHAPTER TEN: SUMMARY CONCLUSION AND RECOMMENDATIONS		121
10.1	Research Work Summary	121
10.2	Research Findings	122
10.3	Future Research Suggestions	124
LIST OF REFERENCES		125

LIST OF FIGURES

Figure 1: Advance warning signs	18
Figure 2: Marking design experimented in the simulator	32
Figure 3: Comparison of running RLR with and without marking in the simulator	32
Figure 4: probability to stop based on logistic regression model for 30 mph and 45 mph	33
Figure 5: Location of test and control intersections.....	38
Figure 6: Alafaya Trl. and Gimini Blvd. Intersection layout.....	39
Figure 7: Alafaya Trl. and Central Blvd. intersection layout	39
Figure 8: design of the "signal ahead" marking.....	42
Figure 9: Detailed designs of the letters for "signal ahead"	43
Figure 10: Theoretical location of dilemma zone as the travelling speed changes in an intersection.....	47
Figure 11: marking road side view	50
Figure 12: Marking view from a vehicle	51
Figure 13: Sample of the marking awareness survey ballot	52
Figure 14: Video Based system for data collection	56
Figure 15: Snapshots from camera #1	58
Figure 16: Snapshots from cameras #2 and #3	58
Figure 17: The Iteris wireless Vantage camera.....	61
Figure 18: Intersection configuration and illustration of camera position.....	62
Figure 19: Red light running rate and traffic volume Patens.....	69
Figure 20: Average RLR rate of before period (red light runner/hr/1000veh)	70
Figure 21: Distributions of stop/go decision by distance interval from the intersection ..	73
Figure 22: Distributions of RLR violation by distance interval from the intersection	74
Figure 23: Classification tree diagram for the stop/go decision model	78
Figure 24: Independent variable importance to the stop/go decision model	79
Figure 25: Classification tree diagram for the RLR model.....	81
Figure 26: Independent variable importance for the RLR model.....	82
Figure 27: Relationship between yellow-entry time and vehicle's yellow-onset distance	84
Figure 28: percentage of RLR distribution by distance interval.....	87
Figure 29: Distribution of stopped drivers' percentage over the distance from the stop bar	90
Figure 30: intersection scatter of red light running rate over three periods.....	94
Figure 31: Average RLR rate difference for each time period	95
Figure 32: Red light running trends over the days of the week	100
Figure 33: Red light running trends of working days vs. week end	102
Figure 34: Variables normalized importance of the tree model	105
Figure 35: Red light running classification tree model.....	106
Figure 36: Part (a) of the classification tree, top portion of the tree	106
Figure 37: Part (b) of the classification tree, right portion of the tree	107
Figure 38: Part (c) of the classification tree, central part of the tree	108
Figure 39: Part (d) of the classification tree, left part of the tree.....	109
Figure 40: Relation between traffic volume-Heavy vehicles and red light running.....	117
Figure 41: Relation between traffic volume-Heavy vehicles and red light running different angle plot.....	118

Figure 42: Relation between traffic speed and red light running.....	119
Figure 43: Relation between percentage green time and red light running	120

LIST OF TABLES

Table 1: Probabilistic dilemma zone boundaries*	21
Table 2: Dilemma zone length and location variation with speed.....	46
Table 3: Experiment periods time line.....	48
Table 4: percentage of red light runners before and after.....	59
Table 5: Pilot observation for the control intersection.....	64
Table 6: Example of the Camera data output.....	66
Table 7: Descriptive statistics for operating speed (speed) at the onset of the yellow	71
Table 8: Analysis of variance table for speed.....	72
Table 9: Descriptive statistics for yellow-entry time (Y_TIME).....	83
Table 10: Analysis of variance table for (Y_TIME).....	84
Table 11: Awareness Survey Results.....	86
Table 12: Percentage RLR and overall improvement distributed by distance interval	88
Table 13: Total average RLR rate for different study periods.....	92
Table 14: T-test two-sample assuming unequal variance	96
Table 15: Variables description	98
Table 16: Percentage of time periods with red light running change over days of the week	99
Table 17: Percentage of time periods with red light running change between week ends and working days	101
Table 18: Linear regression model	103
Table 19: Red light runing MARS model.....	114

CHAPTER ONE: INTRODUCTION

A signalized intersection is the most logical type of control used for managing the traffic between two crossing roads especially when traffic volume increases to the limit that a four way stop sign costs the traveling public too much delay. An intersection between a relatively major road and a road of less degree is usually signalized to maintain a steady traveling stream at the major road and only interrupting it when necessary. This provides a safe and clear way for crossing traffic to travel.

On the one hand, the traffic signal affects the traffic stream during the change from one phase to another, as in the change from red phase to green phase would change the traffic from stopped case to motion, on the other hand, the change to yellow phase from green (known as the change period) is giving a warning to the traveling traffic that the signal is about to change and they should be ready to safely clear the intersection or stop at the designated stop line.

1.1 Red Light Running Definition

Red-light running is defined as entering and proceeding through, a signalized intersection after the signal has turned red. According to the National Committee on Uniform traffic Laws and Ordinance, (Uniform Vehicle Code and Model Traffic). A motorist is defined as red light runner if; cross the clearly marked stop bar, enters the cross walk, or enters

the intersection while facing a steady circular red light. The driver should remain standing until an indication to proceed is shown.

1.2 Traffic Facts Related to Red Light Running in the U.S.

Red light running contributes to substantial numbers of motor vehicle crashes and injuries annually on a national basis. Retting et al reported that drivers who ran red light were involved in an estimated 260,000 crashes each year, of which approximately 750 are fatal, and the number of fatal motor vehicle crashes at traffic signals increased 18% between 1992 and 1998, far outpacing the 5% rise in all other fatal crashes (Retting et al', 2002). According to the Federal Highway Administration, the following traffic facts about red light running were posted in its main website:

- Each year, more than 1.8 million intersection crashes occur.
- In 2000, there were 106,000 red light running crashes that resulted in 89,000 injuries and 1,036 deaths.
- Overall, 55.8% of Americans admit to running red lights.
- More than 95% of drivers fear they will get hit by a red light runner when they enter an intersection.

In 2005, the most recent year for which figures are available, 96 people were killed and 6,300 were injured in Florida by motorists who ignored traffic signals (cause of the crash would be “failed to follow the traffic light”). For the same year, nationally red light running caused more than 800 fatality and 165,000 injuries.

Red light running is not only a highly dangerous driving act but also it is the most frequent type of Police reported urban crash. A study provided 5,112 observations of drivers entering six traffic controlled intersections in three cities. Overall, 35.2% of observed light cycles had at least one red light runner prior to the change phase this rate represented approximately 10 violators per observation hour (Bryan et al., 2000).

The reaction of the driver to the change in signal light from green to yellow differs from one driver to another. Each driver try to evaluate his position from the intersection, vehicle speed, surroundings conditions and many other factors to decide whether to stop or go on yellow light in an intersection. Some times the driver has only few seconds to take the stop or go decision and as an aggressive driver may run the red light leading to a right angle crash exposure at the intersection, an over defensive driver who decide to rapidly decelerate to stop may cause rear-end crash.

1.3 Red Light Running Problem

The change interval creates an area just upstream of the traffic light where a large number of drivers do not know the right decision to make. This area is known as the dilemma zone. Many of the crashes on or near intersections are related to the motorist behavior in this zone resulting from red light running.

A study by Richard A. Retting et. al. in 1995 showed that red light running is a major reason for urban crashes, the research aimed to define and classify the types of urban

crashes and the reasons associated with them, the study found that out of fourteen identified crash reasons the top five types accounts for (69%-81%) of the total crashes the ran red light reason was one of the most common crash type if not the most important (Retting et. al., 1995).

This research aims to build a model representing the motorists' behavior and their reaction towards the signal change interval. The outcome of the effort may provide a better understanding of the reasons and circumstances associated with the red light running incidents. Modeling the motorists' behavior should allow us to measure the effectiveness of different treatments for reducing the red light running rates and thus their related crashes.

CHAPTER TWO: LITERATURE REVIEW

Numerous factors contribute to red light running. Many different scholars tackled the subject from multiple points of view. Conclusively most of research done in the area of red light running can be divided into three major types of research. The first type is finding the relationship between red light running and crashes; this usually is concluded from studying the intersection crash data and the most common reason for crashes. The second type is studies that try to model the red light running behavior and determine factors associated with it. The third type of studies attempt to evaluate different countermeasures to reduce the number of red light runners and hence decrease the crash exposure.

In a survey by (Bryan E. Porter and Thomas D. Berry 2001), they conducted a phone survey for 880 licensed drivers and found that one out of each five drivers admitted to have run red light in the last ten intersections, which is a good indication of how common red light running is.

2.1 Safety Issues Involved in Yellow Signal Change

The yellow signal change at signalized intersections is used to warn approaching drivers of an imminent change in right-of-way. At the onset of the yellow signal indication (amber phase), drivers who are close to intersections may clear the intersections before the signal indication changes to red (also known as change period), while drivers who are

far enough from the intersections should stop at the intersections. Drivers' incorrect decisions of crossing the intersections at the onset of the yellow change may lead to red light running violations or traffic conflicts with the vehicles in front of them whose drivers decide to stop at the intersections.

On a national basis, red-light running and rear end crashes contribute to substantial numbers of severe injuries and property damages crashes. Retting et al reported that drivers who run red lights were involved in an estimated 260,000 crashes each year, of which approximately 750 are fatal. Also in their research they found that the number of fatal motor vehicle crashes at traffic signals increased 18% between 1992 and 1998, far outpacing the 5% rise in all other fatal crashes (Retting et al., 2002).

Also Retting R.A. et al, in 1999 studied crash data of five years period and found that a total of 3753 fatal crashes in FARS met the red light running definition. These crashes resulted in 4238 deaths. This represents approximately 3% of all fatal crashes. A total of 97% of the red light running crashes involved two or more vehicles; 3% involved pedestrians or bicyclists. The number of fatal red light running crashes increased 15% from 702 in 1992 to 809 in 1996. Their research also showed that red light running crashes were twice as likely as other fatal crashes to occur on urban roads and were more likely than other fatal crashes to occur during the day.

A study provided 5,112 observations of drivers entering six traffic-controlled intersections in three cities (Porter and England, 2000). The result showed that 35.2% of

observed light cycles had at least one red-light runner prior to the onset of opposing traffic. This rate represented approximately 10 violators per observation hour. Based on the Florida Crash Database (FCD), it was found that red-light running is particularly relevant to urban crashes (69.89%) and the crash risk in urban area could be 25 percent higher than rural area. Additionally, the most crashes happened at intersections with the 45 mph speed limit (31.22%), followed by the 35 mph (24.1%), and the least crashes happened for the 55 mph (2.2%) (Yan et al., 2005).

Rear-end crashes are also among the most common of types of crashes, accounting for 30.5% of all police-reported crashes in the US (1.89 million) in 2004 and resulting in 2083 fatal crashes and 555,000 injury crashes (National Highway Traffic Safety Administration, 2006). Rear-end accidents are the most common accident type at signalized intersections since the diversity of actions taken increases due to signal change. It was found that rear-end crashes constitute 40.2 percent of all reported intersection crashes based on the crash history of 1531 signalized intersections in the state of Florida (Abdel-Aty et al., 2005).

According to the FCD analysis, it showed a clear trend that as the speed limit increases, the risk of the rear-end accidents increases, especially when the speed limit is higher than 40 mph (Yan et al., 2005).

Red light violations may occur at the beginning of the red phase or at a random time point during the red phase. Most of red light running research focused on the former case

which is correlated with the decision of crossing the intersections at the onset of the change period and are more likely influenced by engineering countermeasures or enforcement. Furthermore, reducing red light running rate at the beginning of the red phase would also lead to a decrease in rear end crashes due to the signal change.

2.2 Contributing Factors and Characteristics of Red Light Violation

The law as stated in the Uniform Vehicle Code (UVC) is considered a permissive yellow law, meaning that the driver can enter the intersection during the entire yellow interval and be in the intersection during the red indication as long as he/she entered the intersection during the yellow interval (FHWA, 2003). As of 1992, permissive yellow rules were followed by at least half of the states. However, in other states there are two types of restrictive yellow laws that apply, namely:

Vehicles can neither enter the intersection nor be in the intersection on red; or

Vehicles must stop upon receiving the yellow indication, unless it is not possible to do so safely.

The FHWA report also pointed out that researchers reviewed the police reports of 306 crashes that occurred at 31 signalized intersections located in three states. Traffic-signal violation was established as a contributing factor and the reason for the violation was provided in 139 of the crashes. The distribution of the reported predominant causes is as follows:

- 40% did not see the signal or its indication;

- 25% tried to beat the yellow-signal indication;
- 12% mistook the signal indication and reported they had a green-signal indication;
- 8% intentionally violated the signal;
- 6% were unable to bring their vehicle to a stop in time due to vehicle defects or environmental conditions;
- 4% followed another vehicle into the intersection and did not look at the signal indication;
- 3% were confused by another signal at the intersection or at a closely spaced intersection; and
- 2% were varied in their cause.

The above research results show that red-light running is a complex problem. There is no simple or single reason to explain why drivers run red lights. However, they can be classified into two types, intersection factors and human factors.

A study's objective was to examine selected intersection factors and their impact on RLR crash rates and to establish a relationship between them. The results obtained from the model show that the traffic volume on both the entering and crossing streets, the type of signal in operation at the intersection, and the width of the cross-street at the intersection are the major variables affecting red-light running crashes (Yusuf Mohamedshah, 2000). The FHWA report summed that, among intersection factors are intersection flow rates, frequency of signal cycles, vehicle speed, travel time to the stop line, type of signal

control, duration of the yellow interval, approach grade, and signal visibility (FHWA, 2003).

Bonneson et al. (2002) concluded that the following factors influence the frequency of red-light-running and related crash frequency:

- flow rate on the subject approach (exposure factor),
- number of signal cycles (exposure factor), phase termination by max-out (exposure factor)
- probability of stopping (contributory factor),
- yellow interval duration (contributory factor),
- all-red interval duration (contributory factor),
- entry time of the conflicting driver (contributory factor), and
- flow rate on the conflicting approach (exposure factor).

Human factors that can contribute to the occurrence of crashes include physical or physiological factors (e.g., strength, vision), psychological or behavioral factors (e.g., reaction time, emotion), and cognitive factors (e.g., attention, decision making) (Quiroga et al., 2003).

How intersection factors and human factors interact to increase or decrease the risk of red-light running varies considerably from intersection to intersection. Those factors point to the need to implement engineering countermeasures to improve traffic flow, improve visibility, help drivers make driving maneuvers and reduce conflicts. Other

factors, especially related to deliberate illegal driving behaviors, point to the need to also implement strategies such as improved enforcement and public awareness.

2.3 Research Modeling Red Light Running Behavior and Affecting Factors

Many researches attempted to determine the behavior of the red light violators and the factors that lead to this phenomenon. In 1996 Retting R.A. and Allan F. Williams compared the characteristics of the motorists that violated red light with those who had a chance to run red light and did not. Retting R.A. and Allan F. Williams in their work defined a set of variables that are related to red light running behavior such as: age of the driver, seat belt use, type and size of the vehicle. In 2006 Martinez K.L. and Porter addressed the issue of red light running characterization in a photo enforcement program adding two more variables to the ones mentioned before and these two variables were the presence of red light running camera and the volume of traffic. It was found that a violation is more likely to occur in an intersection without a red light camera and if the violation occur, the violator's car is more likely to be in a higher traffic volume (Martinez K.L. and Porter 2006). Also in 2006 a study by Panagiotis Papaioannou found that high percentage of speeding drivers result in larger dilemma zone and increase the probability of red light running (Panagiotis Papaioannou 2006).

2.4 Characteristics of Red Light Violators

Bonneson (2001) divides red-light runners into two categories. The first is the intentional violator who, based on his/her judgment, knows they will violate the signal, yet he/she proceeds through the intersection. This type of driver is often frustrated due to long signal delays and perceives little risk by proceeding through the intersection. The second type of driver is the unintentional driver who is incapable of stopping or who has been inattentive while approaching the intersection. This may occur as a result of poor judgment by the driver or a deficiency in the design of the intersection. Bonneson further indicated that intentional red-light runners are most affected by enforcement countermeasures while unintentional red-light runners are most affected by engineering countermeasures.

A previous study by Baugley (1988) classified red light violators into three groups:

- (1) Those that could have cleared the intersection before the red, but were delayed either by their own indecision or by slower traffic in front of them,
- (2) Those trapped in the zone in which they could neither stop comfortably nor clear the intersection safely before the onset of the red signal indication, and
- (3) Those that could have stopped comfortably, but chose to run the red light deliberately.

The risk of accidents resulting from the first two types can be reduced by proper signal timing designs; specifically, by deploying the non-dilemma zone change interval. The third type, however, has to be controlled by enforcement and driver's education.

(Tarek Tarawneh and Mohammed Tarawneh 2002) conducted both field observation and survey studies to analyze drivers' compliance and comprehension of the yellow signal indication. It was found that the overall compliance rate was nearly 13%. Female drivers were significantly more compliant than male drivers. Age significantly contributed to compliance, with young male drivers having the worst compliance rate. The survey revealed that 73% of all respondents knew the correct meaning of the yellow signal indication. However, only 21% knew the correct penalties associated with violating it.

Regarding the meaning of yellow signal indication, and the awareness of penalties associated with violating it, the survey revealed that older age, female gender, higher education, longer driving experience, and private license classification were all significantly associated with better understanding. Young male drivers particularly were the least aware of the meaning of the yellow signal indication and penalties associated with violating it. Another study indicated that red light runners, as a group, were younger, less likely to wear seat belts, had poorer driving records, and drove smaller and older vehicles than the drivers who did not run red lights (Retting and Williams, 1996).

Martinez and Porter (2006) investigated the effects of photo enforcement cameras on reducing red light running and characterized the typical red light runner throughout photo enforcement program implementation. Predictors of red light runners included being at a site without a camera or at an intersection before deployment of cameras, being under the age of 26, being from a non-camera city (the driver is not used to the enforcement system), not using a safety belt, and driving in more traffic. While overall red light

running decreased at camera sites, characteristics of the typical red light runner remained the same at camera and non-camera locations.

Using 1999-2001 Florida traffic crash databases, (Yan et al. 2005) examined the overall characteristics of red-light running crashes based on Quasi-induced exposure analysis. The analysis showed that the risk of red-light running crashes for 6-lane highways is higher than 2-lane and 4-lane highways. The relative crash involvement ratio for night is apparently lower than daytime and the crash ratio for weekend is higher than weekdays. Compared to the clear weather, the crashes more likely occur under the cloudy weather and are less involved in rain weather. Geometric configuration of the intersection can also influence the accident occurrence. Especially during daytime, complex intersection geometric conditions such as up/downgrade and horizontal curve may contribute to the higher crash involvement rate. Moreover, Red-light running crashes are more relevant to urban area and most likely happen with 30 and 35 mph speed limits. The results indicated that the younger and older drivers (55 years and over) are over involved in red-light running crashes. There is general consensus among researchers that older drivers tend to process information and take a corresponding action more slowly than younger driver. Slower reaction times for older versus younger drivers contribute to a disproportionately heightened degree of risk especially when older drivers are faced with two or more choices of action. However, younger drivers are more likely related to aggressive driving attitude, speeding, and careless driving. Those behaviors greatly contribute to the red-light running violation and crash occurrence. Generally, while the younger drivers tend to drive in situations conditions that increase their risk, older drivers tend to avoid adverse

conditions in an attempt to compensate for the decline in their driving capability. This concept explained why younger drivers have a larger crash propensity for cloudy or rain weather, but older drivers are less involved in worse weather. Although the driver gender is not a main effect factor associated with the crash risk, it has interaction effects with driver age, vehicle type, and alcohol/drug use. Young male and old female groups are overrepresented in the crashes, and for middle age groups (26-45 years), gender has no apparent crash propensity. Based on vehicle type, vans and light trucks have relatively higher crash risk and large size vehicles have the smallest crash propensity. Considering the interaction effect with gender, male drivers have larger crash propensities for light trucks and large size vehicles.

2.5 Countermeasures to Decrease Red Light Running

Researchers widely debate the best means to decrease red light running. Since the red light running is one of the leading causes for angle collisions numerous researchers and engineers tried to develop methods to reduce its rates. In general these countermeasures can be classified into two main categories. First category focused on enforcement and the second explored design and operation related countermeasures.

2.5.1 Red-light camera

In recent years, numerous attempted to evaluate the effect of red-light camera implementation. A review of the effectiveness of those systems reveals that red light

cameras are effective deterrence tools and have a positive safety impact. Even where the implementation of engineering countermeasures had not preceded the installation and operation of cameras (Quiroga et al., 2003). The review also shows that red light cameras can contribute to an increase in the number of rear-end crashes. The additional rear-end crashes might result from non-uniform changes in the driver behavior. If drivers stop more often and too conservatively for red lights, they may be struck from behind by drivers not intending to stop. Another report (The Red-light Running Crisis: Is it Intentional, 2001) questions whether motorists identified in institute studies as red-light violators are, in fact, innocent drivers who were unable to stop in time to comply with the signals. The fact is that red-light cameras are designed to identify only deliberate violators, those who enter intersections well after the end of a yellow signal phase.

A recent study involved an empirical bayes (EB) before-after research using data from seven jurisdictions across the United States to estimate the crash and associated economic effects of RLC systems. The study included 132 treatment sites, and specially derived rear end and right-angle unit crash costs for various severity levels. Crash effects detected were consistent in direction with those found in many previous studies: decreased right-angle crashes and increased rear end ones (Council et al., 2005). In reviewing the international literature (Retting and Ferguson, 2003), it was summarized that red light camera enforcement is highly effective in reducing red light violations and right-angle injury crashes associated with red light running. Rear-end crashes increased in many studies, but rear-end injury crashes increased less and were more than offset by the reductions in right-angle injury crashes.

2.5.2 Re-timing of Traffic Signal Change Intervals

One of the suggested countermeasures involves configuring traffic signal cycles according to the Institute of Transportation Engineers (ITE) recommendations. By timing traffic signal cycles following these recommendations and possibly increasing the duration of the yellow and red light intervals, the number of red light runners may decrease (Retting and Greene, 1997). In one study, retiming signals led to a decrease in red light runners and was linked to a 12% reduction in injury crashes and a 37% reduction in pedestrian and bicycle crashes (Retting et al., 2002).

2.5.3 Advance Information of Yellow Change

To help drivers make stop/go decision at the onset of the yellow phase, some motorists' information countermeasures are implemented by enhancing the signal display or by providing advance information to the driver about the signal ahead. With the additional information, the probability that a driver will stop for a red signal may increase. The two most prevailing and controversial countermeasures, pre-yellow signal indication and advance warning signs, are ranked at the top of the list.

Advance warning signs are traffic control devices placed near high speed signalized intersections that provide information to drivers regarding whether they should prepare to stop at the upcoming traffic signal or proceed through, as shown in Figure 1. (Smith

2001) employed the Human Factors Research Lab's driving simulator to investigate effects of Advance Warning Flashers at signalized intersections on simulated driving performance. The researcher concluded that AWFs often improve stopping behavior at intersections, but variability in human response resulted in some drivers making a more aggressive—and risky—decision to proceed through the intersection. Sayed et al. (1999) utilized and analyzed data from British Columbia to evaluate AWF effects. The results indicated that intersections with AWFs have a lower frequency of crashes, but the difference between those with AWFs and those without is not statistically significant.

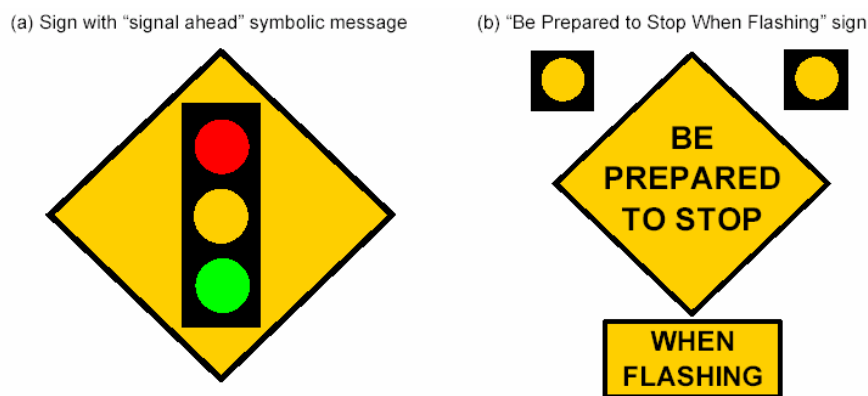

Figure 1: Advance warning signs

The Traffic Light Change Anticipation System (TLCAS) utilizes flashing amber during the last few seconds of the green phase. The flashing amber is considered to be a legal green signal, and is used to warn drivers of the impending termination of the green phase. Some findings indicated that this pre-yellow signal indication could help drivers react more safely to the impending onset of yellow change interval; however, other evaluations showed that the flashing yellow change interval was associated with an increase in rear-end crashes and negligible changes in right-angle collisions (Quiroga et al., 2003).

Another research study used a driving simulator to study the efficiency of TLCAS. Eighteen males and twenty-three females were drawn from the student and staff population at Arizona State University (Newton et al., 1997). The results of the experiment showed an increased variability in first response five times larger than the regular program. This finding, in conjunction with traditional measures, indicates that the TLCAS system performs comparably to an increased yellow change interval by increasing the potential for conflicting decisions between successive drivers approaching an intersection. Altogether, the results suggested that this alternative signal-phasing program would not improve intersection safety.

Over all the reports done by the Institute of transportation Engineers and the Federal Highway Administration “*Making Intersection Safer*” the report stated that there is a need for better red light running database and also that all countermeasures should be studied thoroughly for each intersection before application, the report also stated that the solution to red light running problem should be treated by working on the three Es “education, enforcement and engineering, this means that one of these three will not offer a solution for the problem alone.

In general previous research shows that there is a gap between red light running factors and counter measures. Although research refers to confusion as a major reason for running red light, yet offers “more strict enforcement” as counter measure. While helping motorist through there confusion or hesitation when encountering the change period may

be a very promising way to decrease the number of red light runners and improve intersection safety.

2.6 Dilemma Zone Background in Research

The dilemma zone as defined by the Federal Highway Administration is the area upstream the stop bar at signalized intersections in which the drivers are indecisive about the stop or go decision, (Traffic Detector handbook: Third Edition, October 2006). Also it is described as a zone based on a probabilistic function by Zegeer in 1977. Zegeer in his research defined the dilemma zone as the zone upstream the stop bar where more than 10% and less than 90% of the drivers make the stop decision.

According to the traffic detector handbook the probabilistic dilemma zone varies according to the intersection approach speed as listed in Table 1. This means that the dilemma zone location and width changes with the approach speed. A change of 5 mph changes the can lead to a change up to 56% in the length of the dilemma zone. (Traffic Detector handbook, 2006)

Table 1: Probabilistic dilemma zone boundaries*

Approach speed mph	Distance from intersection for 90% probability of stopping (feet)	Distance from intersection for 10% probability of stopping (feet)	Distance (feet)	Percentage change
35	245	102	143	21.67
40	284	172	112	-56.25
45	327	152	175	-3.42
50	353	172	181	16.02
55	386	234	152	21.67

* (Source: Traffic Detector handbook chapter 4)

Because the traveling speed in an approach near an intersection varies with the change in the volume most of the researchers found that the dilemma zone defined in terms of time can lead to a more uniform determination. In a field study Tim J. Gates et al, tested the stopping characteristics of vehicles 2.5 s to 5.5 s upstream of signalized intersections at start of yellow interval defining this zone as the indecision or dilemma zone. Also Hesham Rakha et. al. 2008 suggested that the dilemma zone should be increased to the time of 1.5 s to 5.5 s. In general the definition of the dilemma zone as time interval increases the uniformity in the numbers and allows the researchers to group data from more than one traveling speed.

CHAPTER THREE: ISSUES RELATED TO RED LIGHT CAMERAS ENFORCEMENT SYSTEM

Red light running cameras system is the most implemented red light running counter measure. It also raises privacy and legitimacy concerns by the general public. This chapter addresses the issues related to implementing the system and examining deferent states, cities and counties experiences.

3.1 How does the System Work

According to Nicholas J. Garber et al, the red light running camera enforcement system have many labels like; photo red enforcement, automated enforcement or several other terminologies. This system mainly consists of one more camera that detects the vehicle running the red light and then takes a photograph of the license plate of violating vehicles that enter the intersection after the signal turns red. Usually the system starts after a given fraction of a second called the “grace period”. The system also record some other information about the violation like time of the violation, date of the violation, speed of the violating vehicle, license plates, and the time elapsed after the onset of the red signal. All this information is recorded along with the photo of the violating vehicle. The data will then be reviewed and validated hence the approved violation sent to the vehicle registered owner.

Some other states promote the responsibility of the driver, in such case a camera must face the front side of the vehicle to prove the identity of the driver. In such case the ticket issued by the system is equal to the ticket issued by a police officer on site including fine value, point, license suspension etc.

3.2 System Effectiveness (Implementation Experience)

The red light camera enforcement system has been implemented in some communities in the United States of America like Virginia, Maine, Georgia, Arizona, and Iowa. Also many countries have been using the system as a possible counter measure for the red light running problem. In the following section we will summarize some of the locations that implemented the system and their findings.

In 1995 Virginia's General Assembly authorized the use of photo-red light monitoring as a demonstration program in 10 jurisdictions in the commonwealth. The program was implemented in 7 jurisdictions from the year 1997 through 2003. Virginia Traffic Research Center prepared several reports on the program and found that often the rear-end crashes increased and in general the number of crashes at the monitored intersections increased also at some intersections the number of injury crashes increased as well.

In Georgia the system was authorized to be used in 2003 and in a study conducted by the Red Light Camera Subcommittee of the Georgia section ITE Safety Committee, although reporting the sample size of the study is not statistically significant, the study found that

the rear-end crashes increased in general with the exception of one location and the other aspects of safety varied from one location to another. The study showed that the system achieved effectiveness in some locations while nearly did not have any effect in other locations.

In Iowa the system was first implemented in 2004 and since then three communities have implemented their systems. In a study by Center of Transportation Research and Education “Iowa state university” it was found that the camera system is highly effective in reducing red light running related crashes and also it succeeded in reducing the rear end crashes at the monitored intersections. The study found that the monitored intersections observed 40% reduction in overall crashes while intersections that did not have the system observed only 12% crash reduction. Also the intersection with red light cameras had 90% reduction in red light running related crashes while the other intersections did not have any reduction. The study found that the monitoring system is effective also in reducing the rear –end crashes as intersections with the system observed 40% reduction in rear-end crashes while the control intersections suffered a 29% increase in the rear end-crashes. This is however the first study to report the reduction in rear-end crashes as a measure of effectiveness for the red light camera system.

Also in Arizona a study was conducted to evaluate the effectiveness of the red light camera system. The study found that the intersection with red light cameras had a decrease in the angle crashes resulting from red light running and increase in the rear end crashes. But the study also stated that there is many confounding factors related to safety

issue and the red light trend at intersections with no red light monitoring cameras might observe reduction in number of crashes related to red light because what is known as the spillover effect. Also the study suggested that the effect of the red light cameras should be evaluated as a system of intersections performance rather than an intersection by intersection. (Kangwon Shin and Simon Washington, 2007)

A study conducted in Australia compared five years before the red light camera system was implemented and five years after the system implementation. The study did not find any overall reduction in the number of crashes resulting from the system. Low crash sites suffered increase in the crash rate and high crash sites experienced decrease in the number of crashes. Also there was significant increase in the rear end crashes (Andreassen, 1995).

Most of the studies agreed that the red light cameras increased the rear end crashes (except Iowa State). And while some of them reported effectiveness in reducing red light related crashes some other studies reported very little or no improvement. It is to be noted that some State treats the citation differently by holding the driver responsible for the violation rather than the vehicle registered owner enabling legal treatment of camera citation as if a police officer issued an in site citation. Most of the other red light camera systems send the citation to the vehicle registered owner regardless of who was driving the car at the moment, usually because of this reason caps have to be put on the fines limit and sometimes no points counted and no insurance reporting.

3.3 System Political Acceptability and Legal Issues

The use of red light camera system to cite motorists for violating red light signal requires legal issues to be addressed by the local authorities in each community to organize the operations and the boundaries of operating the system. In the publication “Guidance for using red light cameras” by Federal Highway Administration and the National Highway Traffic safety Administration, addressing the legal requirements for the red light camera system was pointed out. Some of the issues highlighted by the publication were; privacy, citation distribution and types of penalties. These issues should be thoroughly addressed and resolved prior to the system use start up.

At the present time, there are two approaches that have been adopted by States in the deployment and operation of red light camera systems:

- Driver Responsibility. Where law enforcement alleges a driver has committed a violation and receives a citation, there should be photographic evidence that allows the driver to be identified. This requires that one or more red light camera(s) is/are located so that a frontal view of the vehicle is recorded as it runs the red light. Further, the recorded view should allow the driver and vehicle identities to be clearly determined. If the recorded view of a driver is obstructed or not clear, no citation should be issued. Additionally, a method should be provided through which the registered owner can certify that he or she was not the driver at the time of the violation.

In States where red light cameras are applied as described above, red light violations recorded by red light cameras are considered to be moving violations with citations carrying the same penalties as citations as those issued by law enforcement officers, including "points" and holds on vehicle registration or driver license renewals for unpaid fines.

- Registered Owner Responsibility. Where the registered owner is responsible for the citation, only photographic evidence that identifies the vehicle and its license number is required. Typically, States where red light cameras have been adopted in this manner have enacted legislation at the state level that authorizes the use of red light cameras or permits local agencies to enact local ordinances for use of red light camera systems.

Because the system photographs need to be thoroughly reviewed by a police officer before issuing the ticket in North Carolina for example it was reported that in the first year of system implementation only 40.3% of the number of vehicles caught on cameras were issued a ticket. This number is to be considered a reasonable estimate of the number of the percentage of citations that can really be issued from the system.

Some of the legal issues that relates to the use of red light cameras as stated by the Federal Highway Administration are:

- Authentication of photographs
- Chain of evidence of photographs
- Compliance with enabling statutes
- Foundation: device reliability (maintenance, checks for accuracy, training of personnel involved in the process)
- Misuse or dissemination of photographs
- Municipal drafting, notice – compliance with applicable state rules for service
- Proper notice of use of photo red light enforcement (signs)
- Standing – who can bring an action, when, and where

Most of the legal issues relates to the right of the authorities to issue a ticket based on a photo versus the direct citation by a police officer. This belief of unfair citation may lead to more court challenges and thus increase the burden on the police officers because they will be required to appear at the court for court hearings. Unless this issue is resolved and the public is educated about the fairness of the system and how the citation system works authorities risk increasing the burden on the police officers.

In a report “The Red Light Running Crisis’ by the Office of the Majority Leader U.S. House of Representatives May 2001, the following statement appeared “We are told to accept the idea that our laws should be administered by machines—not human beings—because it is a matter of safety. We must accept this expansion of government and this Orwellian threat to our privacy because cameras are the solution to the so-called red light running crisis.” Such a statement show the public concern about the idea of issuing

citations based only on computer decisions. Thus the public should be made fully aware that the citations are issued by a police officer after reviewing the photos and confirming that there is hard evidence of the violation.

3.4 Need for Better Understanding and Implementation

Some studies proved that there is significant decrease in the number of crashes due to the use of the red light running camera system, on the other hand there is a question about the validity of implementing the system and whether it just a way to tax the motorist rather than promoting safety. Also some studies associated the cameras with significant increase in the number of rear-end crashes. However none of the studies tried to draw a conclusion about the system effectiveness based on the circumstances during which the system was implemented. Such a study can classify the intersections and situations where the red light cameras were effective leading to better implementation of the system and better outcome.

Using the red light camera system is associated with several legal and privacy concerns thus these issues should be addressed, and the public should be educated about how the system works before the system is implemented. It should also be cleared that the cameras are just a way to help police officers monitor the intersection more extensively and that the system does not issue tickets on its own.

Although very few studies reported benefits from the red light camera system, the system should not be discarded altogether. Studies should try to identify when it is justified to use the cameras to achieve better driving conditions for the road users. This research offer a better understanding of the red light running issue and a suggested counter measure that can help reduce red light running rates without increasing neither rear-end crashes nor public anxiety.

CHAPTER FOUR: RESEARCH OBJECTIVES AND METHODOLOGY

When a motorist encounters the change interval at an intersection, he/she is required to evaluate if the distance to the intersection is close enough to cross safely or is he/she supposed to stop. Based on personal evaluation, a motorist is required to make the correct decision in a matter of seconds or shorter. But often there is a chance that the distance to entering the intersection is confusing to the motorist (it is relatively not very close to the stop bar and yet it is not too far), this creates some confusion to the driver which may cause the motorist to run red light.

In a previous study done by Dr. Xuedong Yan a marking placed at calculated distance from the stop bar to help the motorist take a better stop/go decision. Figure 2 shows the view of the tested marking as seen by subjects in the driving simulator. Asking number of subjects to go through a set number of scenarios some of them containing the proposed marking and some are without the marking. Each subject was asked to drive all the scenarios with different speed limits. The marking proved successful in the driving simulator and taking it to the field is the next step of testing its effectiveness as a red light running counter measure. The next section documents in details the previous study carried out in the UCF driving simulator.



Figure 2: Marking design experimented in the simulator

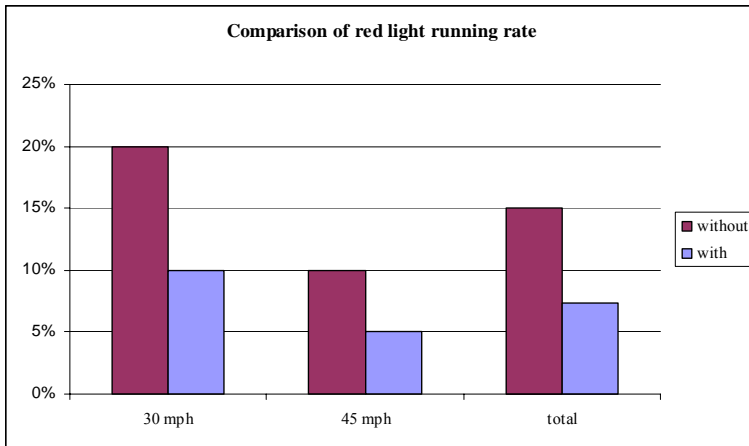

Figure 3: Comparison of running RLR with and without marking in the simulator

Figure 3 shows the reduction in the red light running rate between the “with marking” scenario and “without marking” scenario. Over different speed limits there was 50% reduction in the red light running rate.

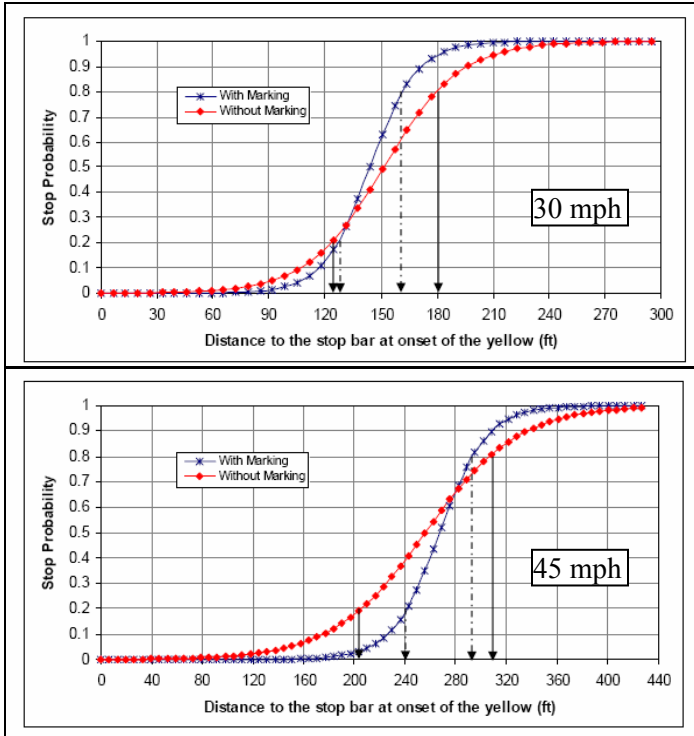

Figure 4: probability to stop based on logistic regression model for 30 mph and 45 mph

Also a logistic regression model was developed and it showed that the probability of the indecision zone or the confusion zone have been reduced for the “with marking” scenarios versus the “without marking” scenario as shown in Figure 4.

4.1 Research Objectives

- 1) Field-test a new marking design that proved to reduce red-light running frequency in a simulation experiment.
- 2) Collect data using appropriate cameras to determine pattern of red light running violations.

3) Observe behavior of red light running phenomena and statistically evaluate the different factors and their impact on red light violations.

4.2 Research Tasks

1) Select two intersections.

One intersection used as the test location for the new marking and the other as control for the experiment.

2) Collect data from the “before” phase.

Collect traffic data related to red light running from both intersections for the period before installing the marking in real world.

- Number and rate of violations (using Iteris Cameras)
- Stop and go probability (using video tapes)

3) Collect data from “after” period without media campaign.

Collect the same type of traffic data after installing the marking at the test intersection before informing the public with media campaign.

4) Media campaign period.

Advertise the new marking purpose to the public through various media portals for example: Central Florida Future, Orlando Centennial, local TV channels and others.

5) Collect data from “after media campaign” period.

Collect more traffic red light running related data to evaluate the effect of the marking as counter measure for red light running.

6) Evaluate market penetration.

Conduct a survey to measure degree of awareness about the new marking in the campus community which is believed to be the major contributor to traffic going through the test intersection.

7) Assess the effectiveness of marking.

Compare the different periods to conclude the potential effect of the marking in decreasing the red light running rate thus increasing safety at the intersections.

8) Develop a statistical model for violations as a function of relevant factors like: traffic composition, speed, volume.

Use statistical methods to model the effect of different traffic aspects on the red light running rate.

4.3 Behavior Study for the Proposed Marking

There are a large number of factors that affect the phenomenon of red light running as indicated in the literature. Factors related to human aspects like; age, gender or aggressiveness of the driver some other factors are related to traffic and surrounding conditions like; traffic density or velocity of traffic. As indicated, there are numerous factors with different influence to the red light running. While an engineer offer a countermeasure to reduce the red light running explores all the engineering factors related to the phenomenon, he/she will attempt to target the correct counter measure and the red light running type to target.

Knowing the factors that pertains the most to red light running is the first step to introduce proper countermeasure. This study focused on the Engineering factors related to red light running.

The study team chose to concentrate on the following factors:

- DISTANCE (in ft): vehicle's distance from the intersection at the onset of the yellow indication;
- SPEED (in mph): vehicle's operating speed at the onset of the yellow;
- ST_GO: driver's stop/go decision;
- Y_TIME (in sec): time elapsed from the onset of the yellow until the vehicle entered the intersection, if the vehicle crossed intersection;
- RLR: whether the going vehicle ran a red light or not;
- LD_FL: whether the vehicle was in a leading position or a following position in the traffic flow;
- L_POSITION: the vehicle's lane position (left, middle or right);
- V_TYPE: vehicle type;

4.4 Before and After Study to Evaluate the Effectiveness of the Marking

The new marking designed to help the drivers make the stop/go decision as the driver approach the intersection during change phase. The marking is designed to help the motorists caught in the confusion zone make a stop/go decision. As mentioned before,

this design was previously tested in the CATSS simulator and proved successful in helping the drivers assess their ability to clear the intersection or make a safe stop.

4.4.1 Concept of the Marking

The marking tackles the problem of confusion and hesitation in the stop/go decision near intersection. This is usually defined as drivers in the dilemma zone during yellow onset. While using time to define the dilemma zone boundaries yields more uniform definition, time to stop bar is not tangible in the real world. Using the time to the stop bar is really dividing the distance from the stop bar by the vehicle traveling speed, this can be a good approximation to create uniformity in the data for analysis proposes. But to create a counter measure the designer must consider distance as the primary factor that the driver relates to when taking the stop/go.

The marking should be positioned at a distance that will allow the drivers upstream to make a safe comfortable stop; at the same time it should be placed as close to the stop bar as possible allowing drivers downstream to clear the intersection safely.

4.4.2 Experiment Description

The method suggested to conduct this experiment is monitoring two relatively similar intersections for a period of time to measure the red light running rates. After a monitoring period we name it as the ‘before’ period, the marking was installed to one of

the two intersections and the other intersection was used as a control intersection to the experiment. Both of the intersections will then be monitored for another three month without informing the motorists about the marking. A media campaign is to follow for educating the motorists about the existence of the marking and how they should use it to make better stop go decisions.

The two intersections that were used to conduct the field experiment are located on a three lane highway in the east Orlando metropolitan area (N. Alafaya Trl.). The two intersections “Alafaya Trl. and Gemini Blvd.” and “Alafaya Trl. and Central Blvd.” were picked because they both have similar geometric characteristics and posted speed limit. The first intersection was used as test intersection and the second was used as experiment control. Figure 5, Figure 6 and Figure 7 show the intersections chosen for the study both have three lanes of through traffic and dedicated right turn and left turn lanes.

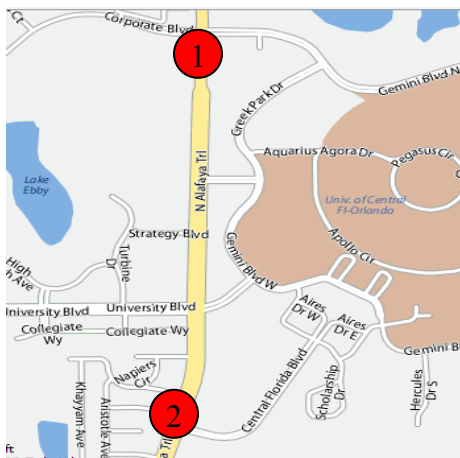

Figure 5: Location of test and control intersections



Figure 6: Alafaya Trl. and Gimini Blvd. Intersection layout



Figure 7: Alafaya Trl. and Central Blvd. intersection layout

4.5 The Marking Design Details

Figure 2 shows a snapshot of the marking as it was tested in the CATSS simulator. The marking location relative to the stop bar depends on the design and operational speed of the roadway section. To be able to achieve maximum benefit the marking should be positioned with careful balance. The marking should be close enough so that if the driver has crossed it when the signal turns yellow the driver is able to cross the intersection safely without running the red light or causing conflicts with the crossing traffic. At the same time it must be positioned far enough to provide adequate stopping distance for the vehicles that have not crossed it when the signal turns yellow. The distance from the marking to the stop bar is calculated by the following equation:

$$X_s = Vt + \frac{V^2}{2d} \quad (1)$$

Where:

X_s = distance from the marking to the stop bar, ft

V = design speed, 5 mph higher than speed limit, ft/sec

t = reaction time, (typically 1.0 s)

d = comfortable deceleration rate, (typically 11.2 ft/sec²)

In case that operation speed is higher than speed limit, design speed ($v_d = v + 5mph$) is used. According to the equation (1), calculations for the marking spacing from the

intersection stop bar for road ways operating at 45 mph are shown as the following:

For 45 mph speed limit (50 mph design speed): $X = 314.2 \text{ ft (95.8 m)}$

Suggested distance of the marking centerline is 315 ft.

According to the MUTCD manual, the following recommendations are listed for word and symbol markings:

- Large letters and numerals should be a minimum of 6 feet in height. Larger lettering and symbols improve visibility.
- No more than three lines of information should be presented at one location.
- If more than one line of message is included, the first word should be nearest approaching drivers.
- Spacing between words or symbols should be at least four times the height of those characters for low speed roads, but never more than ten times that height.
- Words and symbols should cover no more than one lane width, except for School markings, which may extend over two lanes.

Because of the long approval procedures required by the DOT for any new proposed message given on the US highways the research team decided to go with already standard marking in use approved by the DOT and there is no safety liability issues in using it verses other more direct messages like “stop on yellow” or “yellow ahead” will require a separate study to determine the comprehensibility before implementation.

The detailed design of the “signal ahead” marking is illustrated in Figure 8. Based on FDOT Design Standards for pavement marking (Sheet No. 1, Index No. 17346), the detailed design of the letters for “signal ahead” is illustrated in Figure 9.

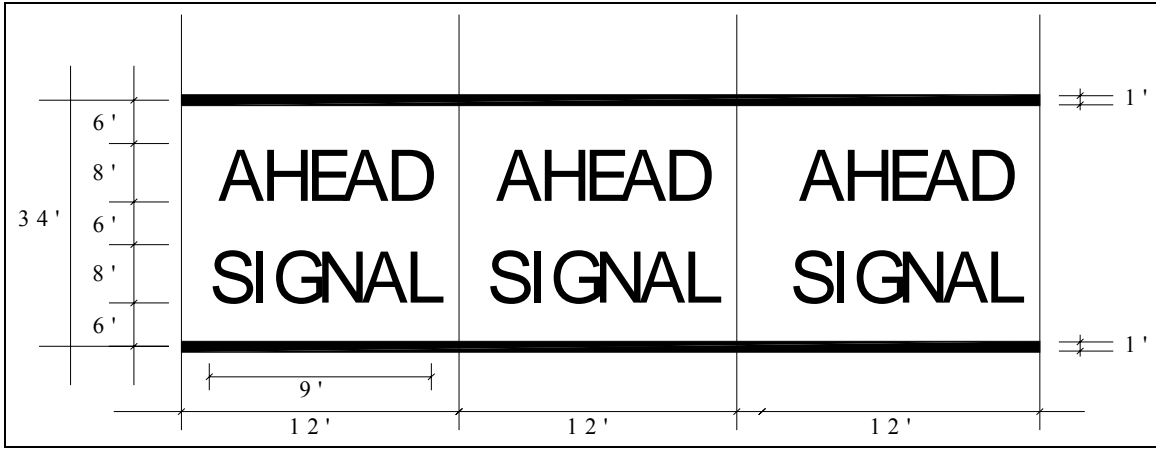

Figure 8: design of the "signal ahead" marking

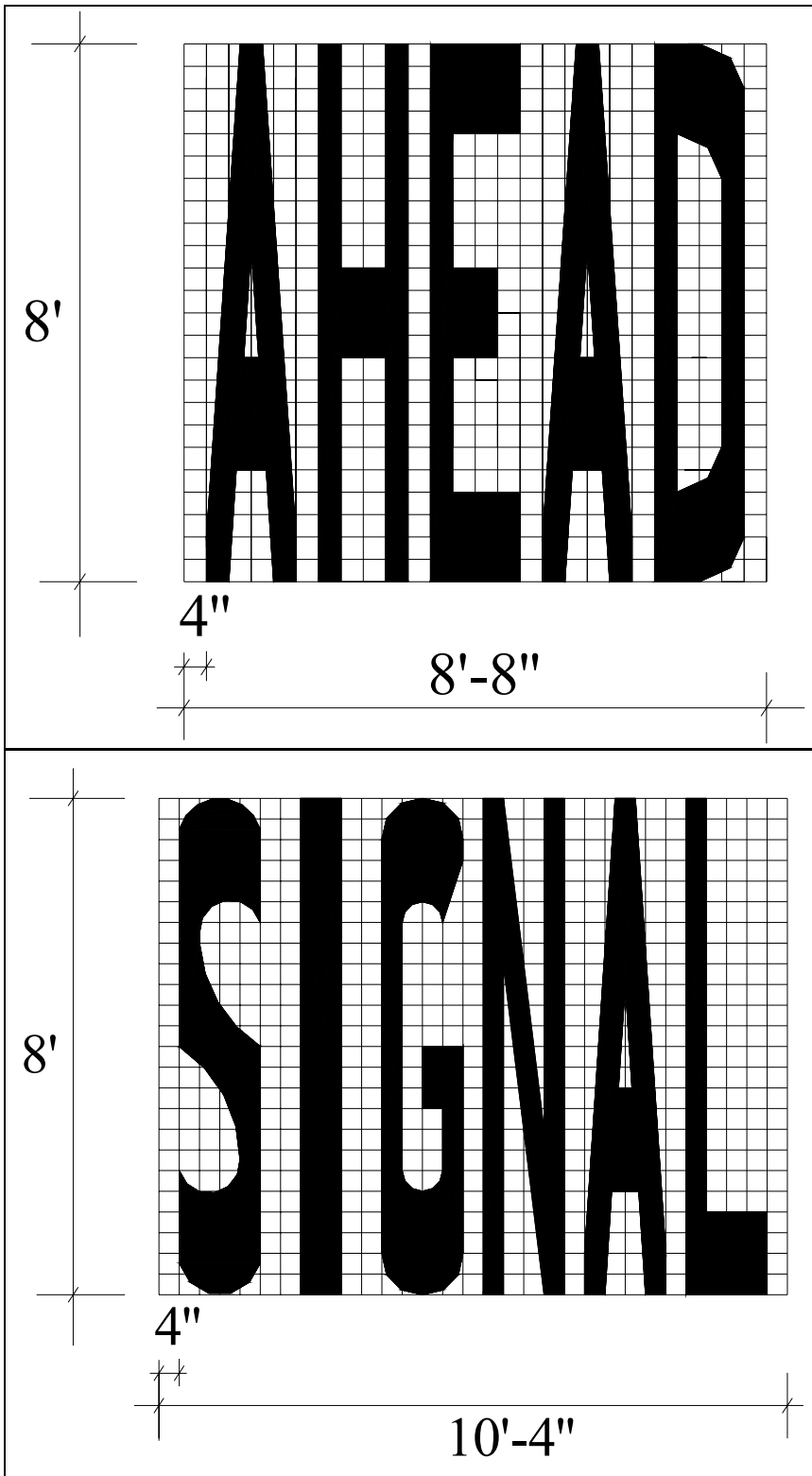

Figure 9: Detailed designs of the letters for "signal ahead"

4.6 Relation Between the Marking and the Dilemma Zone

The dilemma zone is defined as the zone upstream the intersections where the drivers get confused about the stop go decision; this zone can be calculated for every specific intersection. The lower limit of this zone is the stopping sight distance (X_s) and the upper limit is the clearance distance (X_c). This clearance distance is the farthest distance from which a driver can clear the intersection safely (depends on the width of the intersection and the vehicle length).

X_s can be calculated using equation (1) and X_c can be calculated as following (Traffic Detector handbook chapter 4):

$$X_c = V(Y + R) - (W + L) + \frac{a(Y + R - t)^2}{2} \quad (2)$$

Where:

X_c = clearance distance, ft

t = perception and reaction time (typically 1 sec)

a = acceleration rate, ft/s²

Y = yellow change interval

R = red clearance interval (all red)

W = effective width of intersection, ft

L = length of the vehicle, ft

V = approach speed, ft/s

When $X_c=X_s$, the dilemma zone vanishes and the sum of the yellow change interval and red clearance interval expression is simplified as shown in the following equation (Traffic

Detector handbook chapter 4):

$$Y + R = t + \frac{V}{2d} + \frac{(W + L)}{V} \quad (3)$$

Where:

Y = yellow change interval

R = red clearance interval (all red)

t = perception and reaction time (typically 1 sec)

V = approach speed, ft/s

d = comfortable deceleration rate, (typically 11.2 ft/sec²)

W = effective width of intersection, ft

L = length of the vehicle, ft

Assuming an intersection with approach posted speed limit of 45 mph (a corresponding design speed of 50 mph), it has effective width $W=40$ ft, and vehicle length of $L=20$ ft., the traveling speed through the intersection usually varies, and thus the dilemma zone varies from one vehicle to another. Dilemma zone calculations are show in Table 2.

Table 2: Dilemma zone length and location variation with speed

Traveling speed									
mph	fps	t s	d ft/s ²	W ft	L ft	$Y+R$ s	X_s ft	X_c ft	Zone length ft
55	80.67	1	11.2	40	20	5.092	371.19	392.62	21.4306
50	73.33	1	11.2	40	20	5.092	313.38	355.24	41.8587
45	66.00	1	11.2	40	20	5.092	260.46	317.92	57.45848
40	58.67	1	11.2	40	20	5.092	212.33	280.59	68.26103
35	51.33	1	11.2	40	20	5.092	168.95	243.22	74.27127
30	44.00	1	11.2	40	20	5.092	130.42	205.90	75.47284

The dilemma zone location as the traveling speed changes is plotted in Figure 10. Using the 315 feet proposed marking location; we can clearly see that using 50 mph for calculation of the position of the marking from the stop bar allow vehicles traveling between 45-50 mph to use it safely, while vehicles traveling at 55 mph can not make a comfortable stop using the marking. Hence the argument that it is safer to use the design speed over using the posted speed is appropriate.

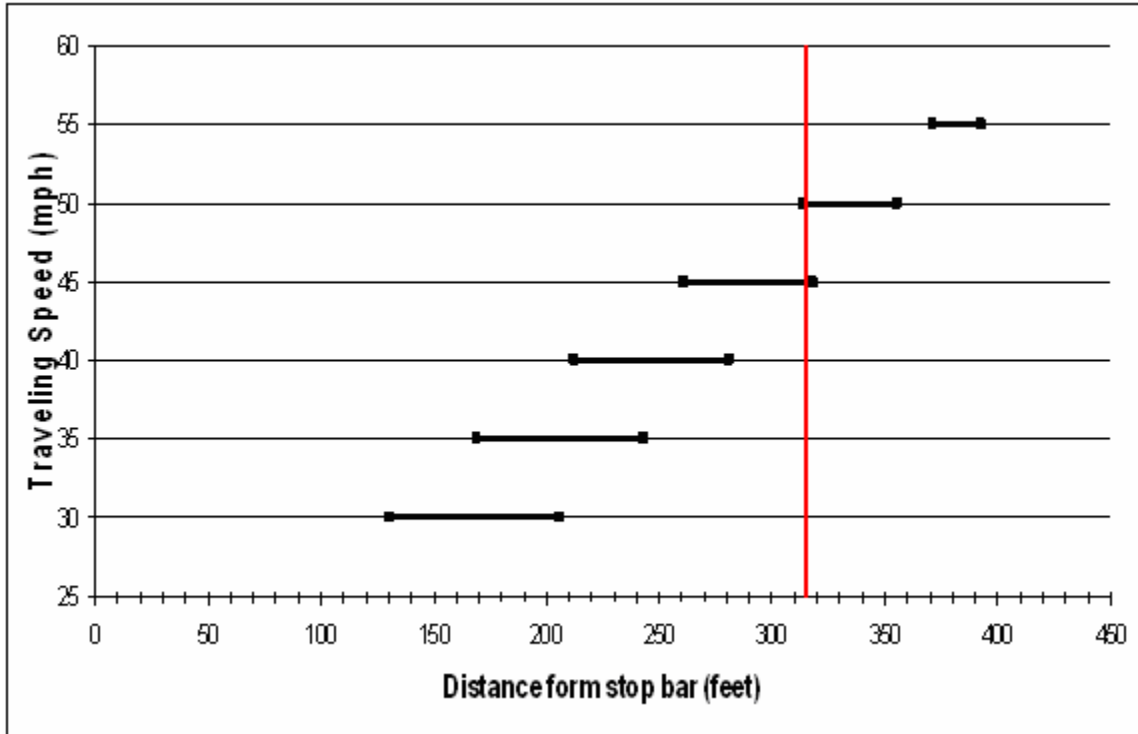

Figure 10: Theoretical location of dilemma zone as the travelling speed changes in an intersection

CHAPTER FIVE: RESEARCH PHASES

To test the marking effectiveness we divided the study time frame in to three time periods: “before”, “after”, and ”after media”. The first period “before” was monitoring the selected intersection before installing the marking to get the RLR rates before the marking. The “after” period was monitoring the intersection just after installing the marking. Following the “after” period, a media campaign was conducted to educate the public about the marking and its purpose. Lastly, an “after media” period was conducted to determine the full potential effect of the marking. The experiment time line is illustrated in Table 3.

Table 3: Experiment periods time line

year	2007							2008					
Month	Jun	Jul	Aug	Sep	Oct	Nov	Dec	Jan	Feb	Mar	Apr	May	Jun
“before” period													
“after” Period													
Media campaign													
“after media”													

5.1 Before

The “Before” phase is essential to determine the RLR rate at the experiment intersections before the marking installation. This mainly establishes a datum to which the RLR rate after installing the marking should be compared to. The “Before” phase is monitoring the

intersection without any interference from the study group and see how the traffic behaves normally. This phase lasted for three month June, July and August 2007.

5.2 After Without Media

The marking was installed in September 4th at the test intersection and the control intersection was left unchanged, ending the “Before” Phase and starting the “After” Phase. This phase is designed to monitor the change in the traffic behavior after the marking installation. It should be noted that in this phase there was no information released to the public motorist about the marking and its purpose. This phase lasted for 4 months September, October, November and December of 2007.

5.3 Media Campaign

The wftv.com⁹ covered the story for starters; their coverage included the reason of the marking and details about how it should be used. The news on the website also included a complete description of the experiment and its different phases.

The website coverage can be found at the following link:

http://www.wftv.com/video_legacy/15195881/index.html

5.3.1 University Media Coverage

The “Central Florida Future” newspaper is the University of Central Florida on campus official newspaper for the student body and faculty. Through this news paper the new marking was covered extensively. The research topic was first page topic on Wednesday, February 6 2008. The University of Center Florida News and Information website have the story published online with two photographs illustrating how the marking look on the pavement. Figure 11 and Figure 12 show the marking as it appears in the intersections the two photos were taken from the online media coverage at UCF news and information.



Figure 11: marking road side view



Figure 12: Marking view from a vehicle

In addition to that all the UCF students, Staff and Faculty received an email explaining the marking and what its purpose is through the daily circular email sent to all the university body.

The media campaign was followed by a survey to examine the success in the campaign in educating the public about the marking. Figure 13 shows a sample of the survey sheet.



Marking Awareness Survey



1. Do you drive by this intersection? Yes() No()

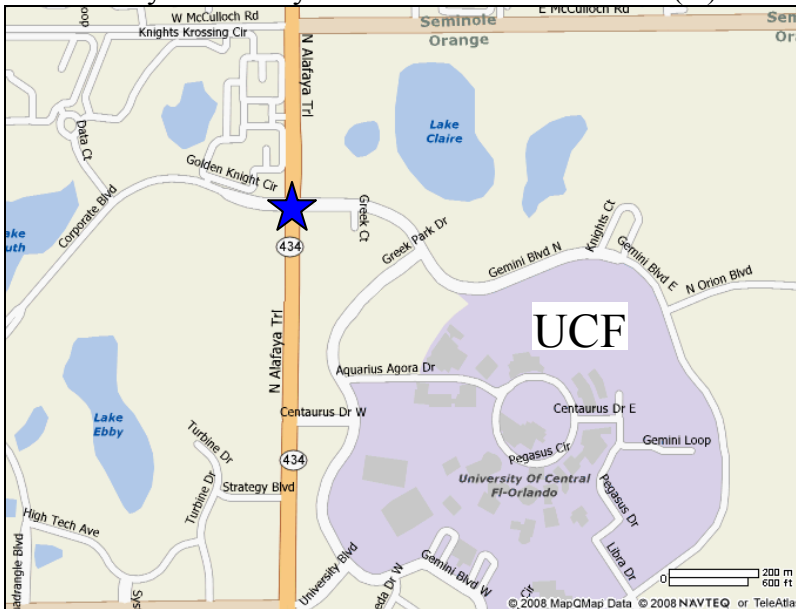

2. Did you notice this marking? Yes() No()



3. Do you know its function? Yes() No()

4. How did you come to know about the marking?

Figure 13: Sample of the marking awareness survey ballot

5.4 After With Media

After the media campaign the “After media” phase started. This phase was to examine the full effect of the marking as a red light running counter measure after the media campaign. This phase lasted for February, March April, May and June of 2008. This is the final phase of data collection and was followed by extensive data analysis.

CHAPTER SIX: METHODS OF DATA COLLECTION

The research had two data collection methods; the tripod video tape cameras and the iteris traffic monitoring cameras. The regular video tape cameras offer a precise data collection method because through its system an observer can extract a vehicle by vehicle data plus it has the flexibility of capturing traffic video from different angles. On the other hand, regular cameras are not weather proof and require extensive manual handling and monitoring. The iteris traffic monitoring cameras offer the data of 24 hours monitoring at both intersection at the same time but aggregating the data output every 15 min giving less precise data but more extensive information. Thus the research team decided to use both systems to cover as much information as possible.

6.1 Behavior Study for the Proposed Marking Data Collection

A video-based system consists of three cameras was used to record the driving behaviors associated with the signal change.

6.1.1 Data Collection Using Video-Based System

As shown in Figure 14, camera #1 was positioned toward the traffic signal heads to film signal phasing status and vehicles around the stop line; cameras #2 and #3 were positioned in the left side of the approach and vertically toward the highway to film the traffic approaching the intersection during the signal change. Moreover, a marker system

represented by continuous yellow flags at 20-ft intervals along the approach was utilized as relative coordinates, which can help researchers clearly identify the vehicles' distances from the intersection and accurately extract vehicles' speeds at the onset of the yellow. Both cameras #2 and #3 can well support 80-ft distance range. To cover a larger space to obtain stop/go probability as a function of approaching distance, we shifted the locations of the cameras #2 and #3 between 160-320 ft span and 320-480 ft span alternatively at each time of data collection. In this method, the whole video-filming space utilized for driving behavior analysis ranged from 160 ft to 480 ft upstream from the intersection.

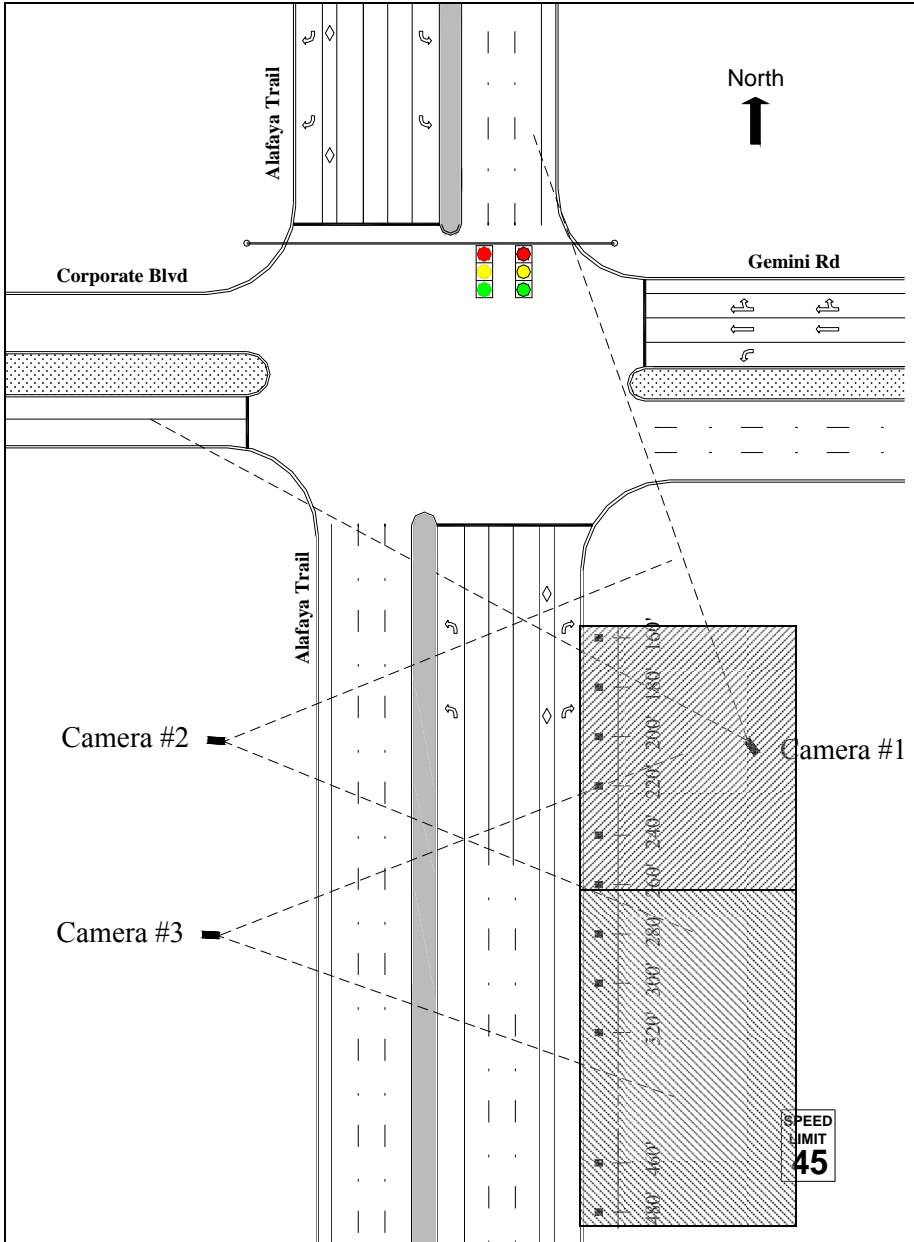

Figure 14: Video Based system for data collection

6.1.2 Extracting Data from Videos

A total of 36 one-hour videos including 28 off-peak hours (1:30 pm to 4:30 pm) and 8 peak hours (4:30 pm to 6:00 pm) were filmed during weekdays. Adobe Premiere Pro software was used to upload and compress the videos for computer storage in Window's

WMV format. The video data collection methodology may produce higher quality traffic data than manual methods. With a video rate of 30 frames per second, the error caused by the video program is estimated to 0.03 sec for the event-times data. Due to the analyst's visual judgment error for vehicle positions, the total possible error for the event-times data could be up to 0.1 sec.

Two computers were used simultaneously for video analysis in the Adobe Premiere Pro software. One computer was used to analyze the videos from the camera #1. As shown in Figure 15, the snapshots indicate the moment of signal change status and the moment at which a vehicle is entering the intersection during the yellow or red. From the time-lapse photography, researchers can accurately record yellow or red entry time for the vehicle entering the intersection after green, vehicle size, which lane the vehicle was traveling in, and whether the vehicle was leading or following vehicle in the traffic flow. The other computer was used to analyze the videos from the cameras #2 and #3. As shown in Figure 16, the snapshots indicate the vehicles' positions at the moment that the signal displays a green termination. Based on the marker system (with predefined distances from the intersection) and the corresponding reference lines (with a perspective effect of the two-dimensional graph), researchers can identify vehicle's distance from the intersection. Furthermore, the vehicle's speed can be calculated using an 80-ft distance interval divided by the elapsed time during which the vehicle passed the interval from the beginning point to the end point. A previous study indicated that the video-based speed measurements yield data of comparable quality to the radar speed measurements.

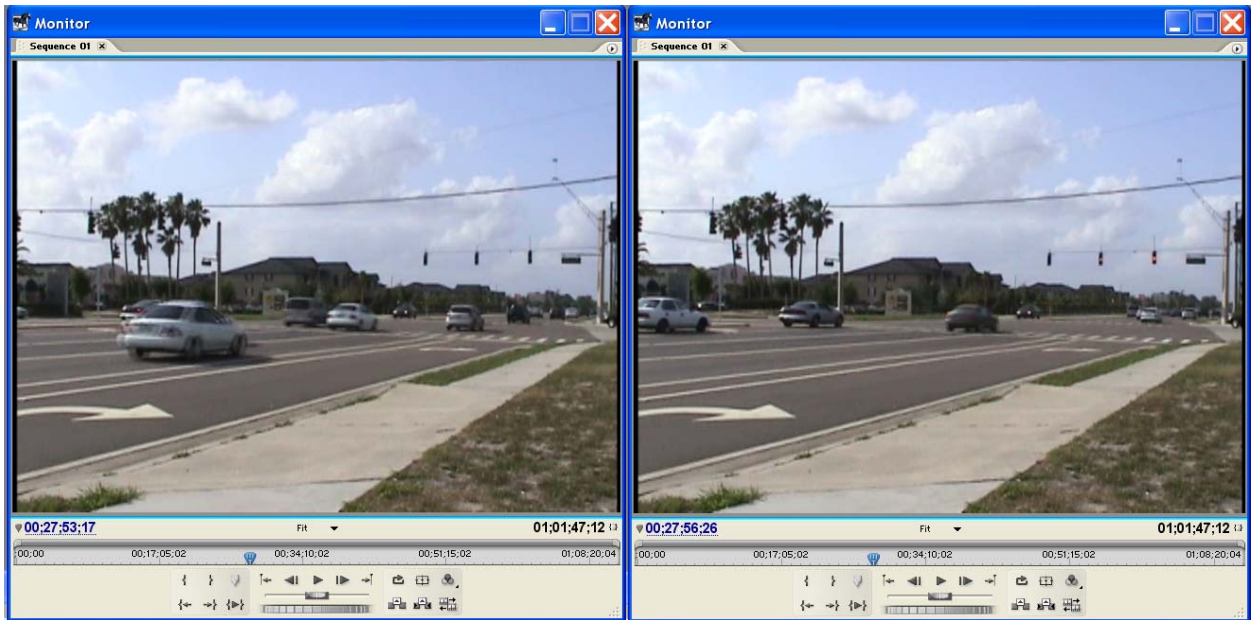

Figure 15: Snapshots from camera #1

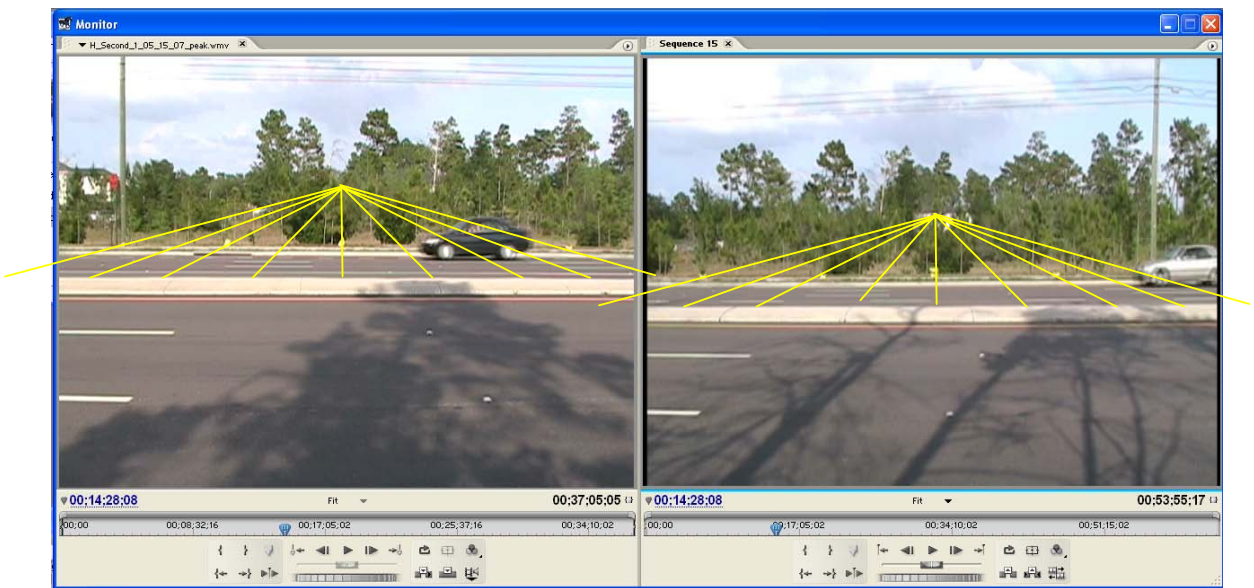

Figure 16: Snapshots from cameras #2 and #3

Using this method for extracting data from videos, a total of 1,292 vehicles for the before period and 493 vehicles for the after period were extracted from the recorded video.

Vehicles that ran the red light or had the chance to run the red light but decided to stop,

were recorded and analyzed. The size of sample does not include vehicles forced to stop by the vehicle in front of it.

Table 4: percentage of red light runners before and after

	Before	After
Percent of red light runners	$p_1=16.65\%$	$p_2=14.22\%$
Percent of non red light runners	$q_1=83.35\%$	$q_2=85.78\%$

From Table 4 we can calculate the sample size necessary to distinguish between the before and after periods. Assuming desired degree of confidence $\alpha=0.05$ and accuracy $H=0.1$ the required sample size is ≈ 101 vehicles (the data set already has adequate number of observations).

$$n = \left(\frac{z_{\alpha/2}}{H} \right)^2 (p_1q_1 + p_2q_2) = \left(\frac{1.96}{0.1} \right)^2 (0.1665 * 0.8335 + 0.1422 * 0.8578) = 100.17$$

For each vehicle whose driver had a chance to make a stop/go decision at the onset of the yellow, the data extracted from the videos were organized into the following variables:

- DISTANCE (in ft): vehicle's distance from the intersection at the onset of the yellow indication;
- SPEED (in mph): vehicle's operating speed at the onset of the yellow;
- ST_GO: driver's stop/go decision (stop = 0; go =1);
- Y_TIME (in sec): time elapsed from the onset of the yellow until the vehicle entered the intersection, if the vehicle crossed intersection;
- RLR: whether the going vehicle ran a red light or not (No = 0; Yes = 1);

- LD_FL: whether the vehicle was in a leading position or a following position in the traffic flow (Leading = 0; Follow = 1);
- L_POSITION: the vehicle's lane position (left lane = 0; middle lane = 1; right lane = 2);
- V_TYPE: vehicle type [passenger car (PC) = 0; light truck vehicle (LTV) = 1; larger size vehicle (LSV) = 2];

6.2 Before and After Study to Evaluate the Effectiveness of the Marking

6.2.1 Traffic Monitoring Camera

The Iteris wireless Vantage camera (Figure 17) was selected for use in this research. Iteris is a leading provider of continuous traffic information which includes current traffic speeds, traffic accidents, roadway construction, travel times, and streaming video traffic cameras. The Vantage® Camera offers the all-round performance for the detection of vehicles in a variety of lighting and weather conditions. Camera is mounted tilted down 20°, or more, below horizontal to avoid direct view of sun or horizon. Usable video is produced for scenes with luminance from 1.0 to 10,000 lux. The camera also includes automatic gain control. The camera's image is normally adjusted to view up to 4 or 5 lanes of traffic. From this image, the Vantage video detection processor can be configured to detect the presence, motion, speed and classification of vehicles. The Vantage V2 rack provides a space-saving solution where a single or dual camera input video detection system is deployed. The V2 rack uses Vantage Edge2 processors and

optionally the Edge2 I/O module. Collected and processed data can be extracted through the on-board EIA-232 serial port.



Figure 17: The Iteris wireless Vantage camera

6.2.2 Camera Installation

For the test intersection, the cameras were installed on the top of the mast arm at which the camera can monitor 4 or 5 northbound traffic lanes. For the control intersection, since there is no signal mast arm can be used, a small camera mast arm used to flexibly hold the cameras were attached on the concrete pole located at the Northeast corner of the intersection. The intersections' configurations and geometries and the camera positions are illustrated in Figure 18.

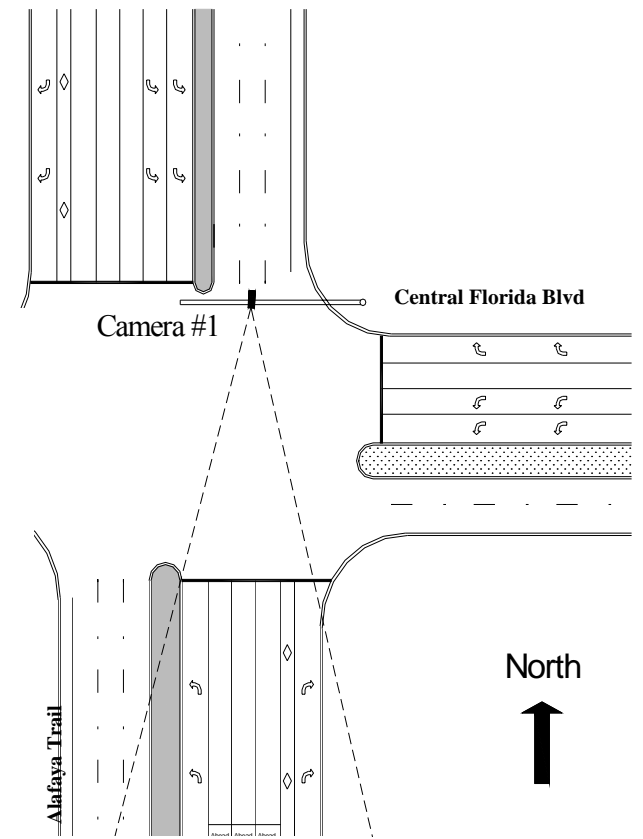
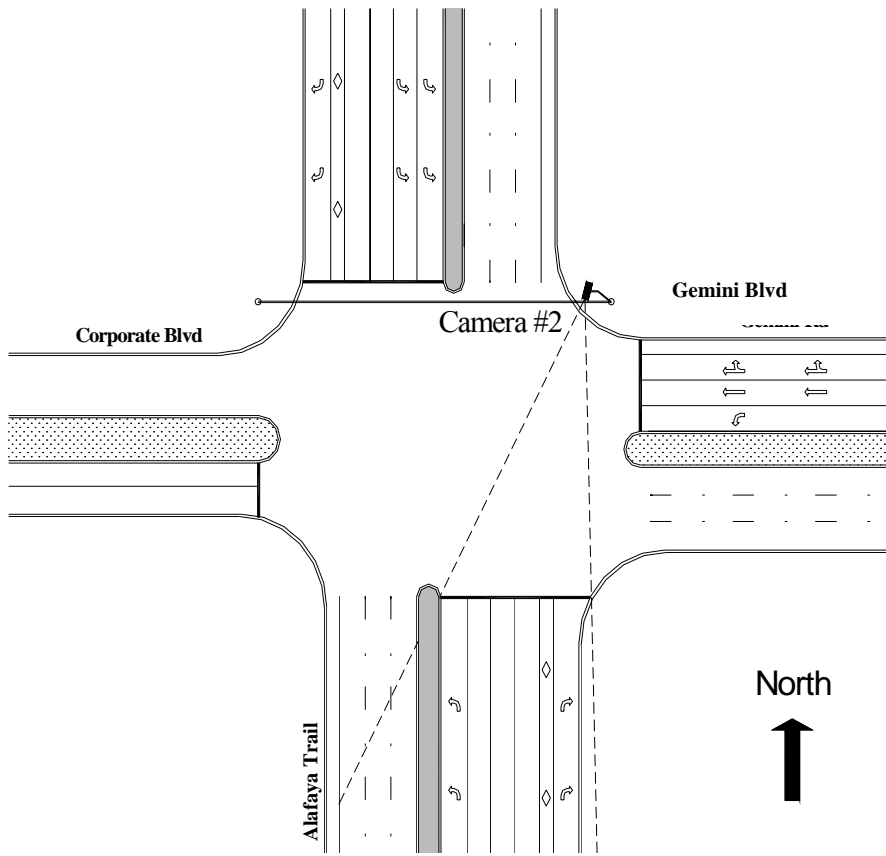

Figure 18: Intersection configuration and illustration of camera position

6.2.3 Pilot Observation of Red-light Running

To ensure that the two selected intersections are proper for a red-light running study, we conducted a pilot observation at the control intersection between 4:00 pm and 5:26 pm on November 15, 2006. The observation results are listed in Table 5. During the one and half hours, we observed 25 red-light running (RLR) violations, which are equivalent to 16.7 RLR per hour or 9.5 RLR per 1000 vehicles. Since the test intersection has more traffic than the control intersection, one can expect that there will be a higher RLR rate at the test intersection. The finding in this pilot study supported our data collection plan. After installing the cameras at the two intersections, we can efficiently collect the data related to RLR violations.

Table 5: Pilot observation for the control intersection

Observation time: 4:00-5:26 pm, Nov 15th, 2006		Location: Northbound approach of Alafaya Trail & Corporate Blvd Intersection (Control Intersection)	
Observer: Xuedong Yan and Noor Elmetiny			
Cycle ID	# of vehicles	Cycle length	# of red-light running
1	57	85	0
2	80	90	0
3	73	72	4
4	101	75	1
5	93	80	0
6	67	77	1
7	88	90	1
8	70	100	1
9	73	80	0
10	77	72	2
11	73	76	1
12	17	40	0
13	59	60	0
14	95	60	1
15	84	55	1
16	84	60	0
17	94	92	2
18	77	67	3
19	105	75	0
20	93	110	1
21	89	62	0
22	81	65	2
23	105	75	0
24	103	65	1
25	114	63	0
26	130	83	2
27	96	65	0
28	130	74	1
29	132	85	0
30	103	65	0
Sum	2643	2218	25
RLR per hour = 16.7			
RLR per 1000 Veh = 9.5			

6.2.4 Data Output from the Camera System

Table 6 shows the data provided by the cameras installed at the test intersections. The cameras record traffic data continually aggregated every 15 min. The variables recorded by the cameras are:

- Lane ID (left lane=1, middle lane=2 and right lane=3)
- Date (date of the recording)
- Time (time aggregated every 15 min)
- Count (volume of traffic)
- Speed (Average traffic speed)
- Count of small vehicles (number of small vehicles in traffic)
- Count of medium size vehicles (number of medium vehicles in traffic)
- Count of large size vehicles (number of large vehicles in traffic)
- Green time
- Number of red light runners

Table 6: Example of the Camera data output

Lane ID	Date	Time	Count	Speed	Occup	Count sm	Count Med	Count lar	Green	Video	Status	RLR
1	6/1/2007	0:00:00	49	28	3	31	9	9	785	Video	OK	0
2	6/1/2007	0:00:00	46	34	2	30	7	9	785	Video	OK	0
3	6/1/2007	0:00:00	19	28	0	17	0	2	785	Video	OK	0
1	6/1/2007	0:15:00	49	28	4	28	12	9	804	Video	OK	1
2	6/1/2007	0:15:00	36	31	3	18	6	12	804	Video	OK	1
3	6/1/2007	0:15:00	25	28	1	13	6	6	804	Video	OK	0
1	6/1/2007	0:30:00	65	28	4	40	16	9	841	Video	OK	0
2	6/1/2007	0:30:00	47	32	3	28	10	9	841	Video	OK	0
3	6/1/2007	0:30:00	26	34	1	13	11	2	841	Video	OK	0
1	6/1/2007	0:45:00	54	27	3	36	9	9	758	Video	OK	0
2	6/1/2007	0:45:00	29	28	2	21	4	4	758	Video	OK	0
3	6/1/2007	0:45:00	20	28	1	14	3	3	758	Video	OK	0
1	6/1/2007	1:00:00	47	30	2	36	10	1	793	Video	OK	0
2	6/1/2007	1:00:00	38	35	3	23	5	10	793	Video	OK	0
3	6/1/2007	1:00:00	25	33	1	15	6	4	793	Video	OK	0
1	6/1/2007	1:15:00	37	28	2	25	5	7	836	Video	OK	0
2	6/1/2007	1:15:00	27	29	2	21	5	1	836	Video	OK	0
3	6/1/2007	1:15:00	19	34	1	7	8	4	836	Video	OK	0
1	6/1/2007	1:30:00	53	28	3	39	8	6	825	Video	OK	0
2	6/1/2007	1:30:00	34	34	2	16	12	6	825	Video	OK	1
3	6/1/2007	1:30:00	16	25	1	9	5	2	825	Video	OK	0
1	6/1/2007	1:45:00	38	26	2	29	7	2	840	Video	OK	0
2	6/1/2007	1:45:00	38	36	2	14	11	13	840	Video	OK	0
3	6/1/2007	1:45:00	19	36	1	11	3	5	840	Video	OK	0
1	6/1/2007	2:00:00	41	26	2	28	9	4	811	Video	OK	1
2	6/1/2007	2:00:00	37	32	2	21	7	9	811	Video	OK	0

CHAPTER SEVEN: RED LIGHT RUNNING BEHAVIOR DATA ANALYSIS

As the data was collected over more than one phase for different periods of times, some of the data was analyzed as collected (if the data was suitable to analyze alone), however most of the data needed to be analyzed collectively to reflect the difference between the phases and the effectiveness of the marking. This section analyze the data collected using tripod cameras for the before period.

7.1 Data Primary Analysis

Since RLR is a rare event in its nature and primarily depends on the number of drivers who encounter signal change and make the wrong decision (as the traffic volume increase the probability of encountering a signal change increase) thus more drivers have a chance to run red light in heavier traffic conditions. The traffic volume was used as a measure of this chance to run red light. The higher the volume, the higher the probability of encountering a yellow signal change thus increasing the probability of RLR. As a measure of effectiveness for this study it was decided to use the RLR rates, calculated as (RLR rate = number of RLR vehicles / the volume of traffic * 1000; units of the RLR rate is RLR/hr/1000veh). This rate uses the volume of traffic to normalize the red light running over the different times of the day.

Analyzing the “before” period data (June, July and August 2007), each data point contains the number of RLR in certain 15 min period and the corresponding volume of

traffic that passed through the intersection (data is recorded for each lane separately). Each data point was then multiplied by four to get equivalent hourly rates.

Plotting the RLR rate (average of each hour for three months) in comparison to the volume we observe that both the test and control intersections had the peak RLR rate during the lowest traffic volume conditions as shown in Figure 19 (a) and (b). Although both intersections agree on this RLR phenomena behavior, this finding should not be generalized because more intersections need to be analyzed before determining any conclusive relations between the red light running and the volume.

Examining the RLR rate at the test and control intersections, it was observed that the test intersection has higher RLR rate than the control intersection as Figure 20 shows. To determine the effectiveness of the marking the research group decided to use the RLR rate difference between the two intersections. The average difference between the test and the control intersection for the “before” period is 53 red light runner/hr/1000 veh. More statistics about the rate difference between the two intersections is to be discussed later in this document.

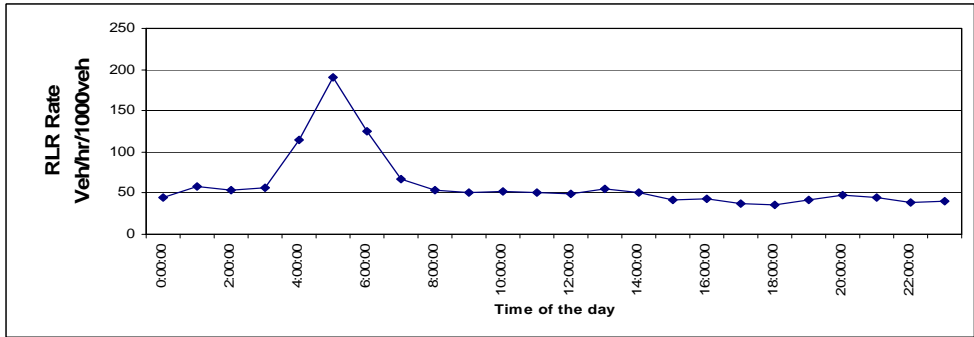
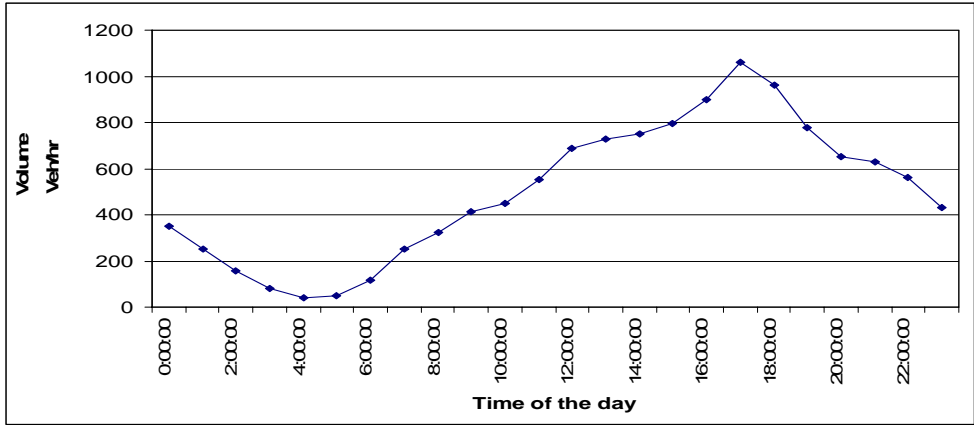

(a) Test Intersection

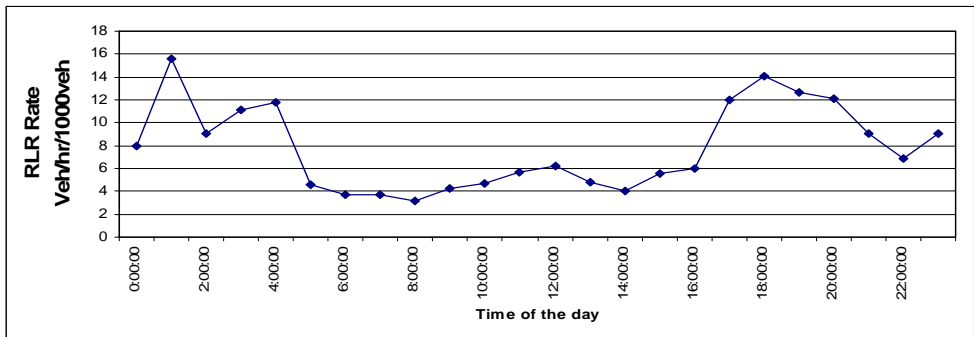
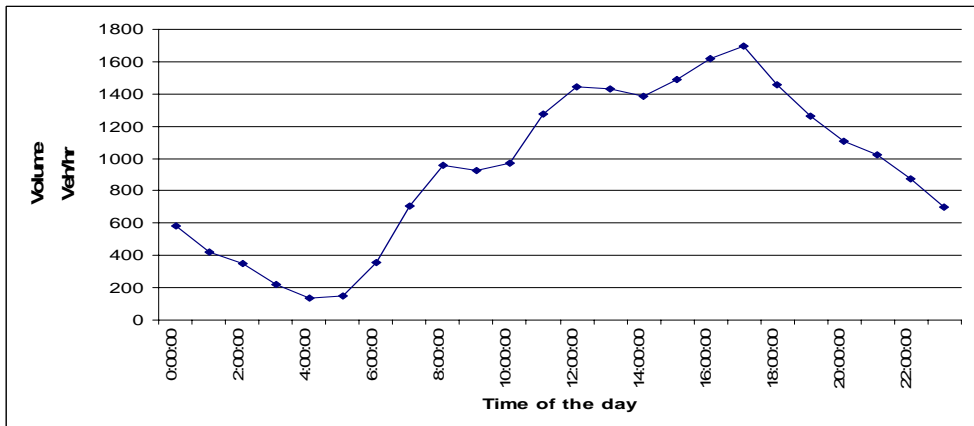

(b) Control Intersection

Figure 19: Red light running rate and traffic volume Patens

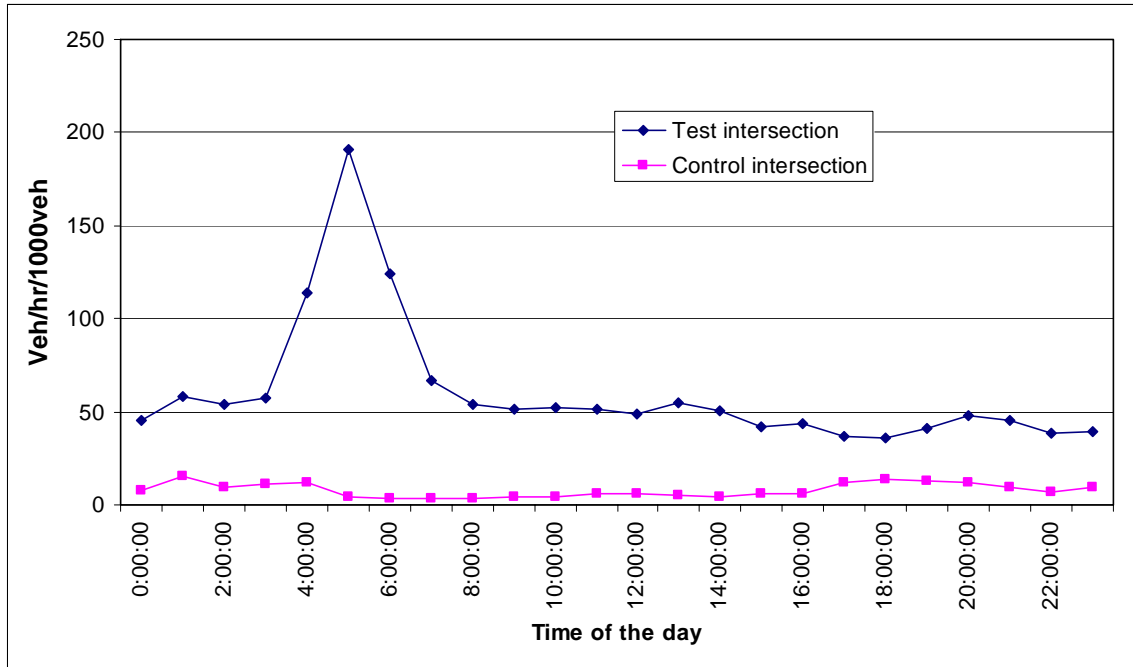

Figure 20: Average RLR rate of before period (red light runner/hr/1000veh)

7.2 Driver Behavior Observation Results and Data Analysis

7.2.1 Operating Speed

Table 7 lists the statistical summary of the operating speeds of vehicles at the onset of the yellow. The mean operating speed at the approach is 48.7 mph, slightly higher than the 45-mph speed limit. As mentioned before, a 50-mph speed limit sign is posted at only 1,000 ft distance downstream from the intersection; therefore, many local drivers tend to speed early before reaching the speed limit sign. In the subsequent statistical analysis, an ANOVA was used to investigate differences between factors (see Table 8). The ANOVA results show that traffic factors including ST_GO ($p < 0.001$), LD_FL ($p < 0.001$),

L_POSITION ($p < 0.001$), V_TYPE ($p < 0.001$) have significant effects on the operating speed, but the mean speed of red-light runners is statistically similar to that of non-red-light runners ($p = 0.323$).

Table 7: Descriptive statistics for operating speed (speed) at the onset of the yellow

Factor	Sub-level	N	Mean	Std. Deviation	Minimum	Maximum
ST_GO	Stop	692	47.8	4.8	25.4	62.8
	Go	600	49.8	5.0	30.2	65.3
RLR	No	1065	48.5	4.9	25.4	62.8
	Yes	227	49.5	5.4	30.2	65.3
LD_FL	Leading	579	49.4	5.0	32.7	65.3
	Following	713	48.1	5.0	25.4	62.8
L_POSITION	Right	470	47.5	5.3	25.4	65.3
	Middle	458	49.7	4.8	32.7	62.8
	Left	364	49.0	4.7	30.2	62.8
V_TYPE	PC	726	49.0	5.0	31.4	62.8
	LTV	538	48.4	5.0	25.4	65.3
	LSV	28	45.5	4.6	36.0	52.7
Total		1292	48.7	5.0	25.4	65.3

Comparisons among sublevels in the traffic factors indicate that the mean speed for vehicles with go decisions ($M = 49.8$ mph, $SD = 5.0$ mph) is higher than that with stop decisions ($M = 47.8$ mph, $SD = 4.8$ mph); the mean speed for the leading vehicles ($M = 49.4$ mph, $SD = 5.0$ mph) is higher than that for the following vehicles ($M = 48.1$ mph, $SD = 5.0$ mph); the mean speed of vehicles traveling at the left lane ($M = 49.0$ mph, $SD = 4.7$ mph) and the middle lane ($M = 49.1$ mph, $SD = 4.8$ mph) is higher than that at the right lane ($M = 47.5$ mph, $SD = 5.3$ mph); and the mean speeds of light-truck vehicles ($M = 48.4$ mph, $SD = 5.0$ mph) and passenger cars ($M = 49.0$ mph, $SD = 5.0$ mph) appear to be not significantly different, but apparently higher than that of large-size vehicles ($M = 45.5$ mph, $SD = 4.6$ mph). These results are consistent with general traffic characteristics

of operating speed at intersections. Furthermore, although the operating speed is independent of RLR, the mean speed of red-light runners ($M = 49.5$ mph, $SD = 5.4$ mph) is statistically higher ($p < 0.001$) than that of vehicles with stop decisions ($M = 47.8$ mph, $SD = 4.8$ mph).

Table 8: Analysis of variance table for speed

Source	Type III Sum of Squares	df	Mean Square	F	Sig.
Corrected Model	3962.368(a)	7	566.053	25.315	.000
Intercept	467346.922	1	467346.922	20900.949	.000
ST_GO	1729.169	1	1729.169	77.333	.000
RLR	21.836	1	21.836	.977	.323
LD_FL	1017.471	1	1017.471	45.504	.000
L_POSITION	890.048	2	445.024	19.903	.000
V_TYPE	485.301	2	242.650	10.852	.000
Error	28710.345	1284	22.360		
Total	3098143.040	1292			
Corrected Total	32672.713	1291			

a R Squared = .121 (Adjusted R Squared = .116)

7.2.2 Stop/Go Decision and RLR

Driver's stop/go decision at the onset of the yellow change is the most essential behavior at signalized intersections. The drivers, who make incorrect go decisions, result in RLR violations. During the data-collection period the following was observed: among the 1,292 drivers who encountered the yellow change 601 drivers made stop decisions, 691 drivers made go decisions, and 227 RLR violations were observed (the driver was identified to have encountered Yellow change if was located between the range of 160-480 ft upstream of the intersection. Drivers closer than that are not likely to stop at the intersection and further away drivers will make the stop as was found by a pilot study

conducted in the field range shown in Figure 14). Figure 21 and Figure 22 illustrates distributions of stop/go decision and RLR violation by yellow-onset distance interval from the intersection. Figure 21 shows that as the distance from the intersection increases, the probability of stop decision increases, but the probability of go decision decreases. When drivers are located in the distance interval of 280 ft to 320 ft, the probabilities of both stop and go decisions are close to 0.5. This similarity means that the 280 ft to 320 ft area is considered the zone where the driver shows largest variability in stop/go decision. Figure 22 shows that most red-light runners were concentrated in the distance interval of 280 ft to 380 ft. When the green signal terminates, drivers close to the intersection are less likely to run red lights unless the vehicles' speeds are very slow; also, drivers far away from the intersection are also less likely to run red lights except for those very aggressive drivers.

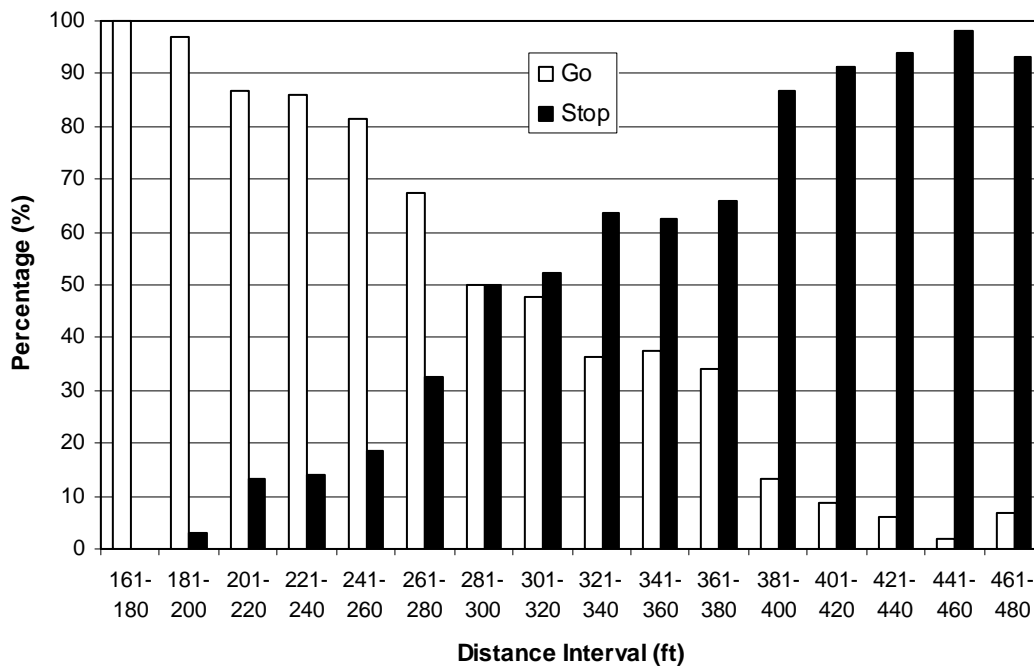

Figure 21: Distributions of stop/go decision by distance interval from the intersection

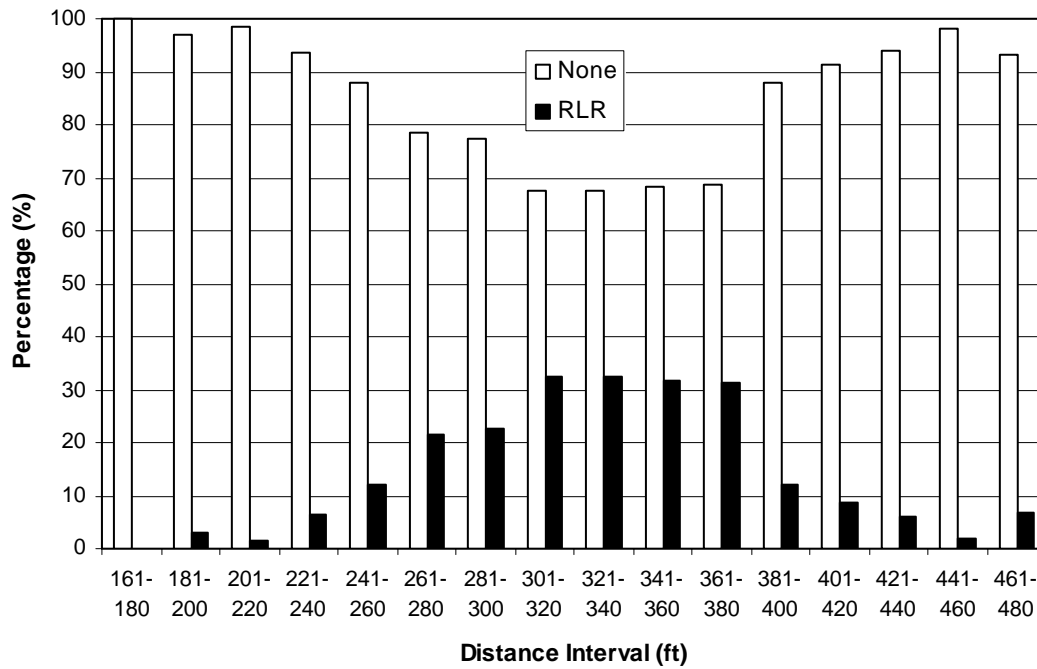

Figure 22: Distributions of RLR violation by distance interval from the intersection

7.2.3 Tree-based Classification Analysis of Stop/Go Decision and RLR

Classification trees, also called decision trees, are among popular statistical tools that emerged from the field of machine learning and data mining. A classification tree classifies observations by recursively partitioning the predictor space. The resultant model can be expressed as a hierarchical tree structure. Due to its nonparametric nature and easy interpretation, decision trees have received wide popularity from various fields, especially since the introduction of the Classification and Regression Trees (CART). The advantage of using classification trees over many of the other methods is the effectiveness to construct classifications of driver behavior through segmenting the data set into smaller and more homogeneous groups. For a classification tree, the target variable takes its values from a discrete domain, and for each leaf node the classification

tree associates a probability for each class (i.e. value of the target variable). In tree-structured representations, a set of data is represented by a node, and the entire dataset is represented as a root node. When a split is made, two child nodes are formed, which correspond to partitioned data subsets. If a node is not to be split any further, it is called a terminal node that is associated with a group membership; otherwise, it is an internal node. The tree structure is constructed following a set of decision rules applied sequentially. Each decision rule is used to form branches (i.e. splitting) connecting the root node to the terminal node at a certain level of the tree. More detailed descriptions of these decision tree algorithms are beyond the scope of the present study. For further discussions of tree methodology, the reader is referred to Breiman et al.

In this study, the classification tree analyses were carried out using the SPSS software package (version 13.0; SPSS Inc., Chicago, IL, USA). The classification trees were developed based on the CART approach, and the Gini criterion (or index) was used as a measure of split criteria. With the CART method, one can avoid over fitting the model by “pruning the tree.” In this study, the tree is trimmed automatically to the smallest sub-tree based on one standard error as the specified maximum difference in risk. Since the data size is not very large, the minimum number of cases for parent nodes was set as 30 and the minimum number of cases for child nodes was set as 10. Additionally, the cross-validation method (10 folds) was used to assess how well the tree structure generalizes to a larger population. The Gini index equation for a discrete probability function $f(y)$, where y_i $i=1$ to n , are the points with nonzero probabilities and which are indexed in increasing order ($y_i < y_{i+1}$):

$$G = 1 - \frac{\sum_{i=1}^n f(y_i)(S_{i-1} + S_i)}{S_n}$$

Where:

$$S_i = \sum_{j=1}^i f(y_j) y_j \text{ and } S_0 = 0$$

Based on these inputs, two binary classification tree models were developed for driver's stop/go decision and RLR, respectively. For the stop/go decision model, the target variable is ST_GO (stop = 0; go =1); for the RLR model, the target variable is RLR (No = 0; Yes = 1). The classification results are depicted and discussed in the following.

7.2.4 Stop/Go decision Model

Figure 23 illustrates the classification tree diagram for the stop/go decision model, which includes 6 terminal nodes. The model generates the following classification rules for the stop/go decision:

If the vehicles' yellow-onset distances are smaller than 287.5 ft, most of drivers (80.9%, 389 veh) would cross the intersection.

If the vehicles' yellow-onset distances are larger than 372.5 ft, most of drivers (92.2%, 317 veh) would stop at the intersection.

If the vehicles' yellow-onset distances are between 287.5 ft and 372.5 ft, the operating speed plays an important role on stop/go decision. If operating speeds are lower than 50.55 mph, drivers are more likely to stop (73.8%, 220 veh); on the contrary, if the

drivers are speeding (higher than 50.55 mph) at the onset of the yellow, they are more likely to cross the intersection (63.3 %, 107 veh).

An interesting finding shows that the speeding drivers are more likely to cross the intersection when they are the following drivers in traffic flows than when they are the leading drivers (74.2%, 66 veh vs. 51.2%, 41 veh).

Furthermore, for the speeding drivers who are the leading drivers in traffic flows, vehicle types have a significant effect on their stop/go decisions: light-truck vehicles are more likely to cross the intersection than passenger cars and large-size vehicles (71.4%, 20 veh vs. 40.4%, 21 veh).

Additionally, Figure 24 shows the independent variable importance to the stop/go decision model. According to the importance order in the figure, DISTANCE, SPEED, and LD_FL are the most important variables to predict drivers' stop/go decisions; however, V_TYPE and L_POSITION are less significant.

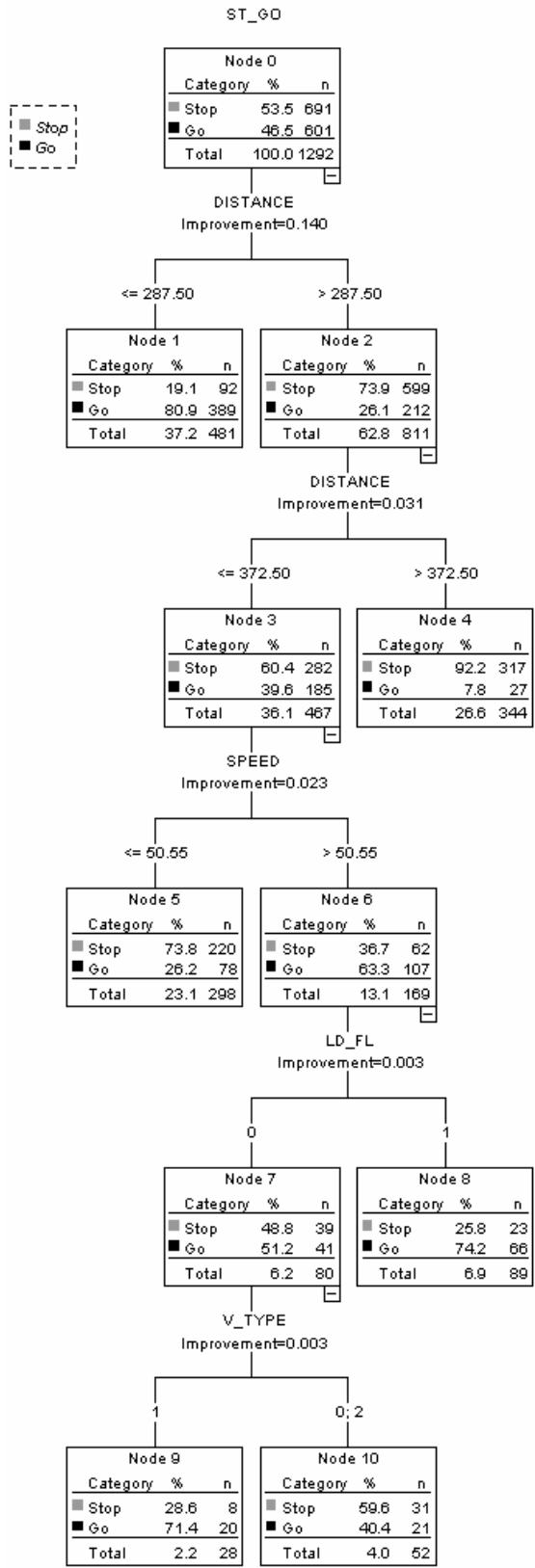

Figure 23: Classification tree diagram for the stop/go decision model

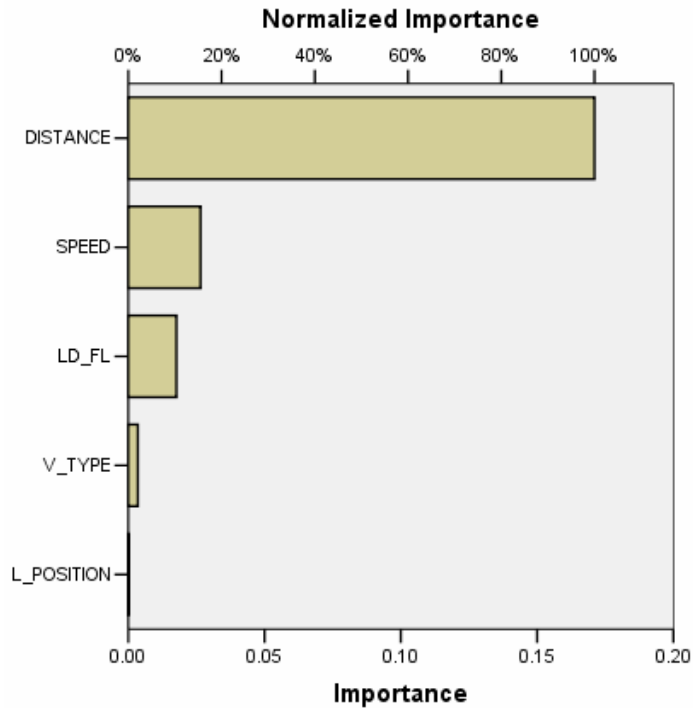

Figure 24: Independent variable importance to the stop/go decision model

7.2.5 RLR Model

Figure 25 illustrates the classification tree diagram for the RLR model, which includes 7 terminal nodes. The model generates the following classification rules to predict the RLR probability

If the vehicles are in the leading positions in traffic flows, the drivers are less likely to run red lights (9.8%, 57 veh).

For the following vehicles, if the yellow-onset distances are smaller than 267.5 ft, few drivers (9.7%, 27 veh) would run red-lights; if the yellow-onset distances are larger than 372.5 ft, 8.7% drivers would have more sever RLR violations (8.7%, 113 veh).

If the following vehicles are located in the distance interval between 267.5 ft to 372.5 ft, the operating speed is significantly associated with the RLR probability, and drivers are categorized into four speed-distance subgroups.

If the vehicle speeds are lower than 46.9 mph and located in the distance interval between 267.5 ft to 282.5 ft, 72.2%, 13 veh drivers run red lights presumably due to the effect of dilemma zone;

If the vehicle speeds are lower than 46.9 mph and located in the distance interval between 282.5 ft to 372.5 ft, 19.3%, 22 veh drivers would run red-lights;

If the vehicle speeds are higher than 46.9 mph and located in the distance interval between 267.5 ft to 292.5 ft, 23.9%, 11 veh driver would run red-lights; and

If the vehicle speeds are higher than 46.9 mph and located in the distance interval between 292.5 ft to 372.5 ft, 56.2%, 81 veh drivers would run red-lights. This subgroup includes 81 RLR observations, which account for 35.5% (81/228) of overall RLR violations.

Figure 26 shows the independent variable importance to the RLR model. According to the importance order, DISTANCE, LD_FL, and SPEED are the most important variables to predict the RLR rate. The difference from the stop/go decision model is that LD_FL plays a more important role than SPEED in the RLR model.

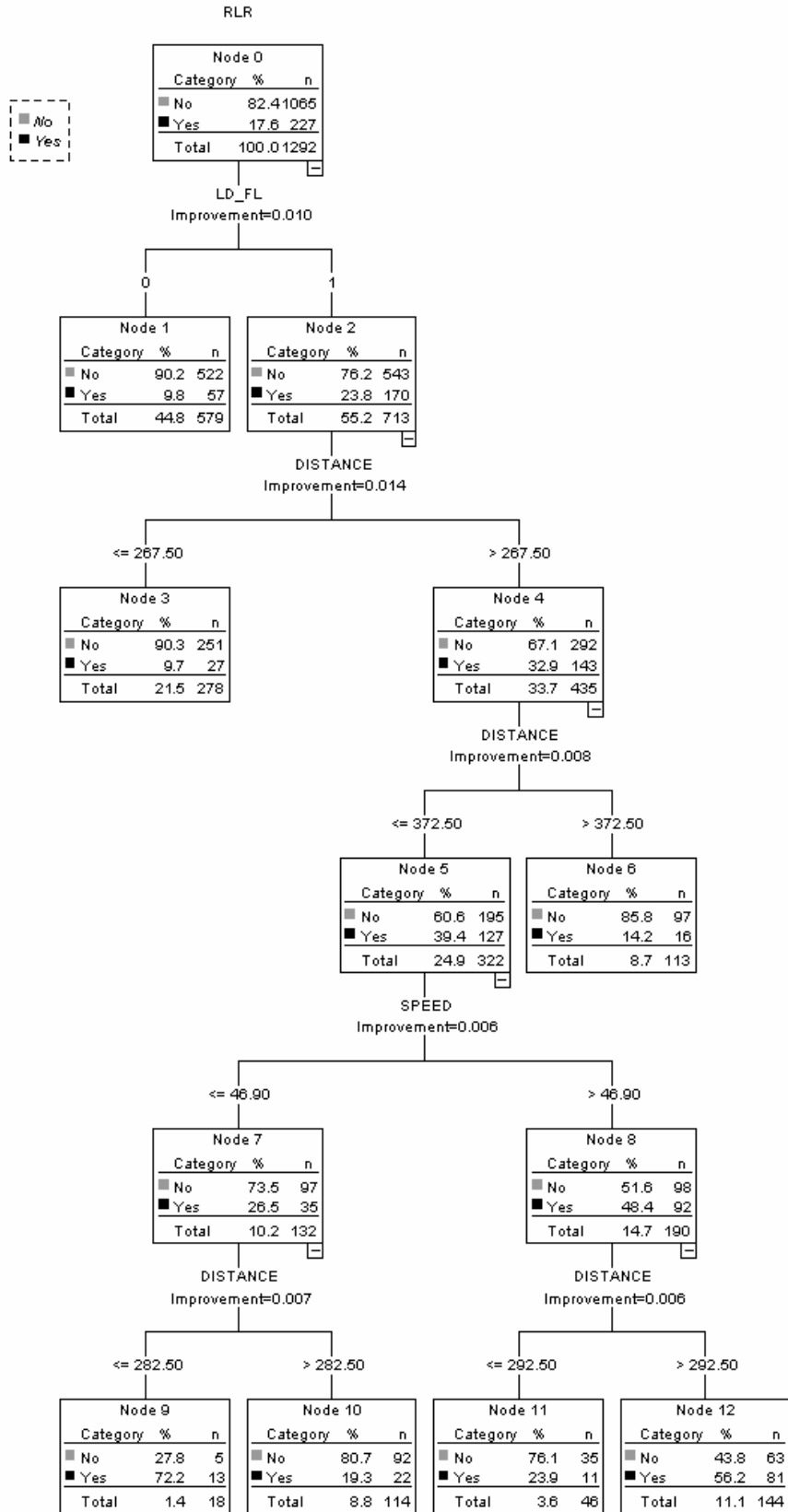

Figure 25: Classification tree diagram for the RLR model

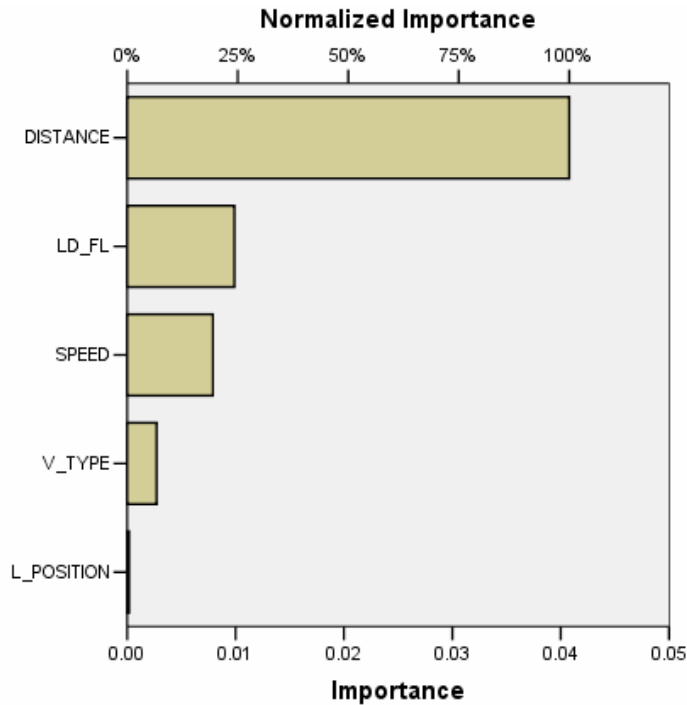

Figure 26: Independent variable importance for the RLR model

7.2.6 Yellow-entry Time

Yellow-entry time is an important measure to analyze the RLR tendency at an intersection. At this intersection, the yellow phase length is 4.3 sec, and therefore, any entry times larger than this value indicate a RLR violation. Furthermore, the later a vehicle enters the intersection after the red, the more likely the conflicting traffic will be moving through the intersection, and the more likely a RLR crash will occur. The descriptive statistics of yellow-entry time is presented in Table 9. The ANOVA result (see Table 10) shows that factors including LD_FL ($p < 0.001$), V_TYPE ($p = 0.037$) are significantly associated with the yellow-entry time, but L_POSITION ($p = 0.215$) is not ($p = 0.204$). It was found that the average entry time for the leading vehicles in traffic flows ($M = 3.8$ sec, $SD = 0.8$ sec) is shorter than that for the following vehicles ($M = 4.0$

sec, SD = 0.8 sec); and the average entry times of light-truck vehicles (M = 4.0 sec, SD = 0.8 sec) and passenger cars (M = 3.9 sec, SD = 0.8 sec) are similar, but slightly shorter than that of large-size vehicles (M = 4.2 sec, SD = 0.7 sec). Additionally, the ANOVA result shows that DISTANCE ($p < 0.001$) and SPEED ($p < 0.001$) as two continuous variables are significant covariates associated with the yellow-entry time. Intuitively, yellow-entry time is positively related to the yellow-onset distance. Figure 27 illustrates a relationship between yellow-entry time and vehicle's yellow-onset distance. However, yellow-entry time is negatively related to the operating speed. Given a same yellow-onset distance from the intersection, the vehicles traveling at higher speeds would result in shorter yellow-entry times than those traveling at lower speeds.

Table 9: Descriptive statistics for yellow-entry time (Y_TIME)

Factor	Sub-level	N	Mean	Std. Deviation	Minimum	Maximum
LD_FL	0	182	3.8	0.8	2.1	5.8
	1	419	4.0	0.8	2.4	7.2
L_POSITION	0	209	4.0	0.8	2.1	7
	1	219	4.0	0.8	2.4	7.2
	2	173	3.9	0.7	2.5	6
V_TYPE	0	325	3.9	0.8	2.1	7.2
	1	260	4.0	0.8	2.4	6
	2	16	4.2	0.7	2.5	5.5
Total		601	4.0	0.8	2.1	7.2

Table 10: Analysis of variance table for (Y_TIME)

Source	Type III Sum of Squares	df	Mean Square	F	Sig.
Corrected Model	299.091(a)	7	42.727	297.828	.000
Intercept	54.347	1	54.347	378.821	.000
LD_FL	2.493	1	2.493	17.376	.000
L_POSITION	.457	2	.228	1.592	.204
V_TYPE	.954	2	.477	3.323	.037
SPEED	26.100	1	26.100	181.931	.000
DISTANCE	290.862	1	290.862	2027.444	.000
Error	85.073	593	.143		
Total	9787.750	601			
Corrected Total	384.164	600			

a R Squared = .779 (Adjusted R Squared = .776)

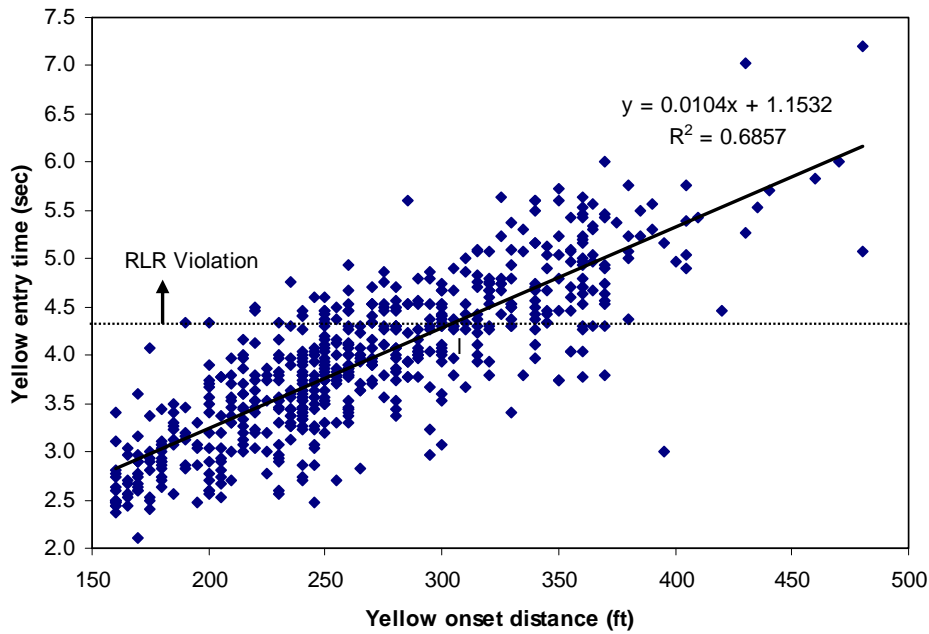

Figure 27: Relationship between yellow-entry time and vehicle's yellow-onset distance

CHAPTER EIGHT: MARKING EFFECTIVENESS ANALYSIS

This chapter concludes all the analysis for the performance of the proposed marking as red light running counter measure. The analysis of the data collected during the three experiment time-periods (“before”, “after” and “After media”) using the data collected from both the tripod video cameras and the traffic monitoring cameras.

8.1 Effectiveness of the Media Campaign

As mentioned before the research team conducted a media campaign to educate the public about the new marking and how to use it to make better stop/go decision. The first step before analyzing the data the research team had to determine the market penetration of the media campaign because the effect of the marking in reducing the red light running rates will be limited to the effect of the media campaign.

To follow the effect of the media campaign a survey was designed to measure the degree of penetration that the media campaign has reached.

The survey had four main questions:

- Do you drive through the subject intersection?
- Did you notice the marking?
- Do you know what the marking is for?
- How did you come to know about the marking?

Results from the media follow up survey included 100 subject of the school on campus community. Total 82% of the subjects use the intersection either on regular or daily bases, shown in Table 11.

Table 11: Awareness Survey Results

	Percentage (Yes)	Percentage (No)
Drive through the intersection	82%	18%
Notice the marking	32%	68%
Know the marking purpose	70%	30%
Three yeses	23%	77%

The survey shows that almost 70 % of the sample was aware of the marking function through media campaign but only 32% of the people who drive through the intersection recognized the marking, thus reducing the percentage of people who had the three yeses (drive through the intersection, saw the marking and know its use) to only 23% percent of the total survey population. We considered the percentage of people with three yeses on the survey as the percentage of people that the media campaign succeeded in conveying the message to and can benefit from the new marking. Still 23% was considered a fair penetration percentage.

8.2 Effect of the Marking on Driver Behavior

The distribution of the red light runners over the distance intervals for the before period was shown in Figure 22 showing a concentration of red light running violators in the intervals of 301-320, 321-340, 341-360 and 361-380. These four intervals had nearly

constant 30% red light running from the population that encountered the signal change, suggesting that drivers caught in this zone are too confused to take proper stop/go decision. Figure 28 shows that there was a drop in the percentage of red light runners in the confusion zone especially in the “after media” period.

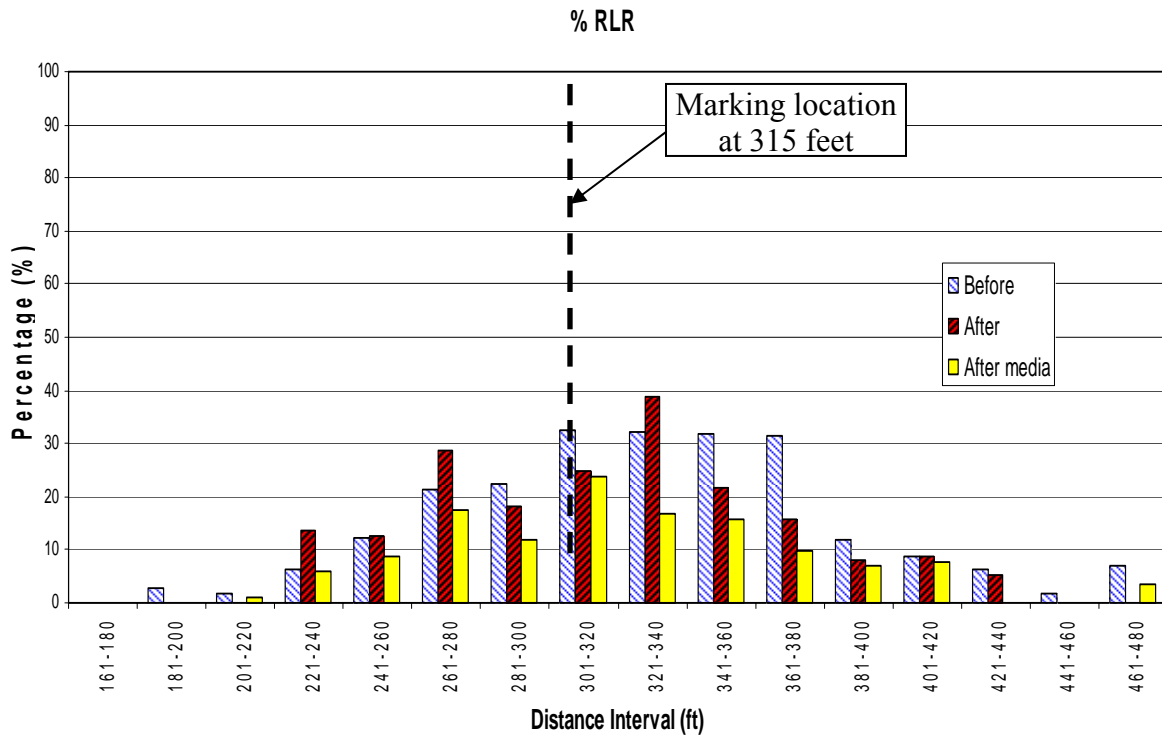

Figure 28: percentage of RLR distribution by distance interval

Table 12 shows that the after media percentage of red light runner is lower than the before marking installation period. The distance intervals 301-320, 321-340, 341-360, 361-380 and 381-400 have the most improvement. This means the area 300-400 ft up stream of the intersection have the most improvement suggesting that drivers in the 100 ft upstream of the marking benefit from the marking most. This area had the most number

of red light runners and thus the marking can be claimed effective in reducing the level of confusion and helping the driver make proper stop/go decisions.

Table 12: Percentage RLR and overall improvement distributed by distance interval

Distance Category	Percentage red light runners			% improvement
	Before	After	After Media	
161-180	0	0	0	0.00%
181-200	2.86	0	0	100.00%
201-220	1.64	0	1.09	33.54%
221-240	6.35	13.64	6.06	4.57%
241-260	12.20	12.50	8.82	27.70%
261-280	21.50	28.57	18.50	13.95%
281-300	22.55	18.18	17.65	21.73%
301-320	32.38	38.17	16.67	48.52%
321-340	32.29	25.00	23.81	26.26%
341-360	31.78	21.62	15.79	50.31%
361-380	31.30	15.63	9.68	69.07%
381-400	12.05	8.00	7.14	40.75%
401-420	8.70	8.70	7.69	11.61%
421-440	6.15	5.26	0	100.00%
441-460	1.75	0	0	100.00%
461-480	6.90	0	3.57	48.26%

8.2.1 Effect of the Marking on Dilemma Zone

The percentage of drivers who take the stop decision at a yellow signal onset increases as the distance up stream of the intersection increases. Generally the distribution follows the shape of an S-curve, close to the stop bar very low percentage of the drivers decide to stop, this percentage increases as the drivers are further away from the stop bar until you reach a point where nearly all the drivers decide to stop. This stop/go decision is based on the driver estimation of the time needed to cover the distance separating him/her from the stop bar.

The percentage of drivers making the stop decision at the intersection was plotted in Figure 29 showing the shift in the trend of the drivers' behavior between the different research phases ("before", "after" and "after media").

If we follow the probabilistic definition of dilemma zone developed by Zegeer in 1977, in his work he defined the dilemma zone as the zone upstream the stop bar where more than 10% and less than 90% of the drivers make the stop decision. Looking at Figure 29 we see that the marking also reduced the size of the dilemma zone by at least 50ft, meaning that in addition to reducing the red light running rate the marking helped drivers make better stop/go decision. Drivers very close to the stop bar made the go decision easier and more decisively eliminating the probable increase of rear end crashes caused by over defensive drivers making unnecessary sudden stops at the intersection when they could have cleared safely.

The shift between the "before" and "after" periods was not noticeable while the shift after the "after media" period was more recognizable, leading to the conclusion that motorist were very comfortable following the guide line provided by the marking to make the stop/go decision once they learned about it.

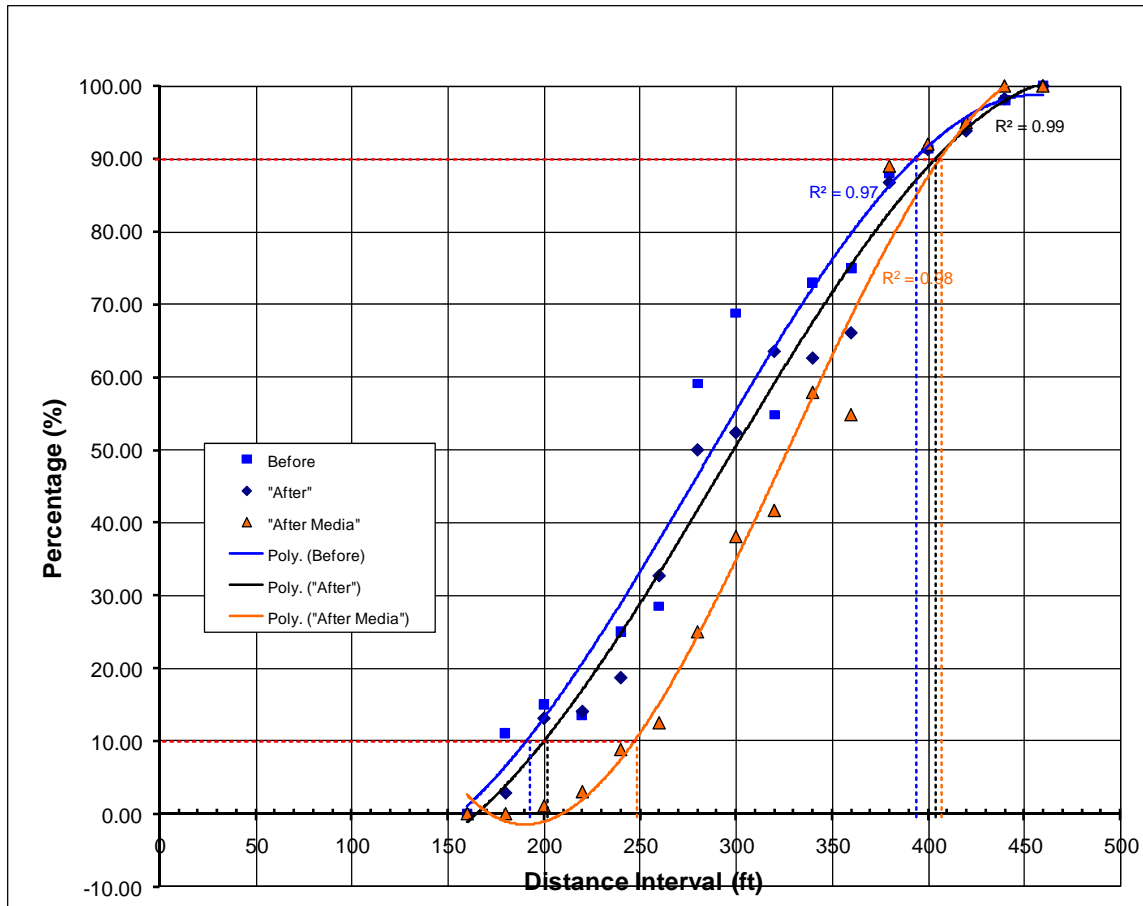

Figure 29: Distribution of stopped drivers' percentage over the distance from the stop bar

8.3 Before-After Analysis of Marking Effectiveness Traffic Monitoring Cameras' Data

The “after media” period followed the media campaign and the survey started in February and extended over March, April, May and June. Due to monitoring camera difficulties and adverse weather condition March data could not be recovered from one of the cameras thus March data was excluded from the analysis. This makes the “after media” period consists of February, April, May and June.

8.3.1 Red-light Running Trends

For the experiment two intersections charts of Average volume, number of red light runners and red light running rates were plotted to examine the relation between volume and number of red light running (the volume factor was very hard to collect from manual cameras due to the extensive manual work required). The test intersection has a single afternoon peak while the Control intersection has two less defined peaks during the day. Considering that the cameras are only monitoring the north bound through traffic it is normal to see a single peak trend like in the test intersection meaning that the Test intersection mainly peaks at the afternoon peak while the Control intersection is affected by different type of traffic peaks.

Generally the red light running volume is higher during the peak operation hours in both intersections but because the traffic volume is higher. That means that there is more Chance of encountering red change period than in the off peak operation hours. The traffic volume was used as normalizing factor to get a feeling of which periods have higher expectancy of running red light.

For this purpose the red light running rate (veh/hr/1000veh) is used as a measure to reflect the times of the day which has the most dangerous red light running behavior.

$$RLR_Rate = \frac{N_R \times 1000}{V}$$

Where:

N_r =Number of red light running vehicles in one hour

V=the volume of traffic Vehicle per hour

RLR_Rate=Number of red light runners per thousand entering vehicle per hour

Analyzing the “before”, “after” and “after media” periods, data each 15 min was considered a separate data point then multiplied by 4 to get equivalent hourly rate. As mentioned before the number of RLR vehicles is divided by the corresponding volume and multiplied by one thousand to get RLR rate per hour per one thousand vehicles.

Table 13: Total average RLR rate for different study periods

Study Period	Test intersection (rlr/hr/1000 veh)	Percentage change	Control Intersection (rlr/hr/1000 veh)	Percentage change
Before	66.59	--	13.82	--
After	49.57	-25.56%	17.70	(+28.08)%
After media	36.12	-45.76%	12.07	-12.66%

The average number of red light runners in the test intersection for the “before” period was 66.59 rlr/hr/1000 veh and for the control intersection during the same time frame was 13.82 rlr/hr/1000 veh. For the “after” period (after marking installation) the RLR decreased in the test intersection to 49.57 rlr/hr/1000 veh recording 25.56% decrease. During the same period RLR increased at the control intersection to 17.70 rlr/hr/1000 veh; recording an increase of 28.08% in the RLR at this location. For the “after media” time period the RLR rate decreased at the test intersection to 36.12 rlr/hr/1000 veh a 45.76% improve, and the control intersection RLR decreased to 12.07 rlr/hr/1000 veh, only 12.66% improvement. Comparison of the average rates is shown in Table 13.

The red light running data was plotted in a scatter diagram versus the time of the day to visually detect any pattern change in motorists' red light running rates behavior. From Figure 30 (a) the test intersection had a change in the red light running distribution after the marking installation. There was a tangible decrease in the red light running during the red light running rate peak (late night). This means that the marking works best during low traffic volume conditions and specially drivers driving at or near the speed limit. Furthermore, the proposed marking design appears to have great potential in helping motorist make better stop/go decision.

For the control intersection there was no change in the red light running rates trend over all the experiment periods. Since all the data scatters plotted are nearly identical in the control intersection as shown in Figure 30 (b), the research team can conclude that the traffic behavior in the study area did not undergo a major change, thus the RLR rates decrease at the test intersection can be claimed a result of the marking existence.

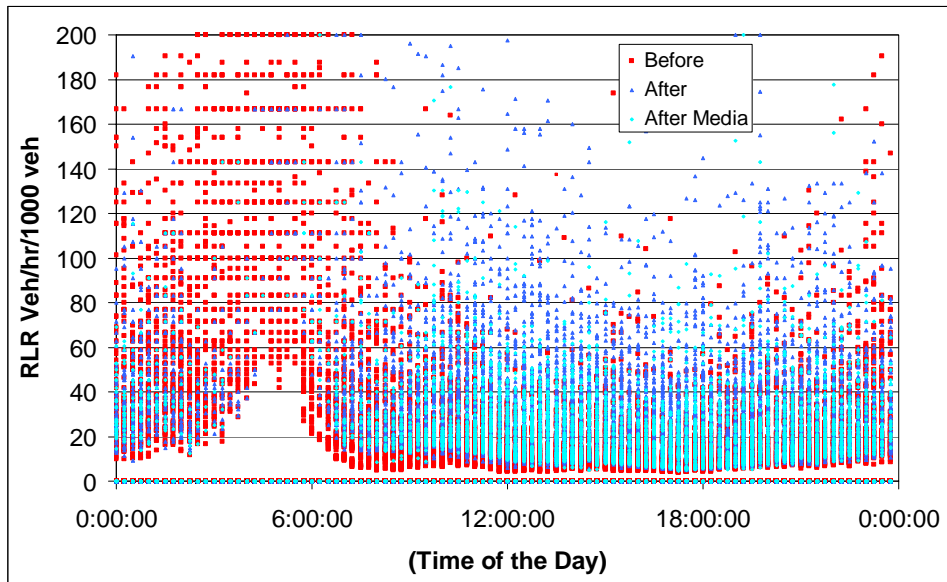

(a) Test intersection RLR rate

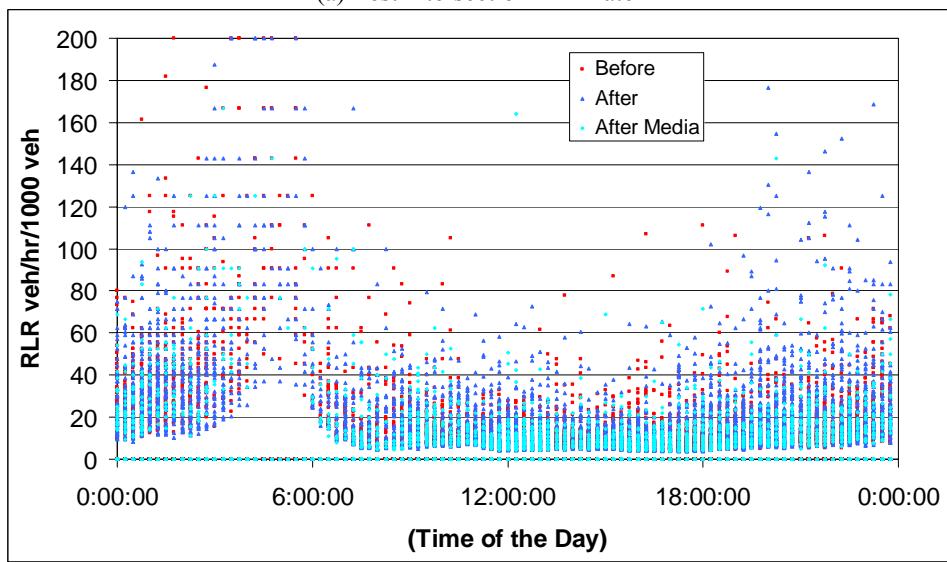

(b) Control Intersection RLR rate

Figure 30: intersection scatter of red light running rate over three periods

As mentioned before, the control and test intersections have different RLR rates and it was decided to use the distribution of the difference between the two intersections RLR rates as a measure of marking effectiveness. As can be observed from Figure 31 the average difference in RLR rate for the “before” period was 53 rlr/hr/1000 veh, for the

“after” period the difference was 32 rlr/hr/1000 veh (decrease of 39.62% from the “before” period), and for the “after media” period the difference between the two intersection decreased to 24 rlr/hr/1000 veh (decrease of 54.72% from the “before” period and decrease of 25.00% from the “after” period).

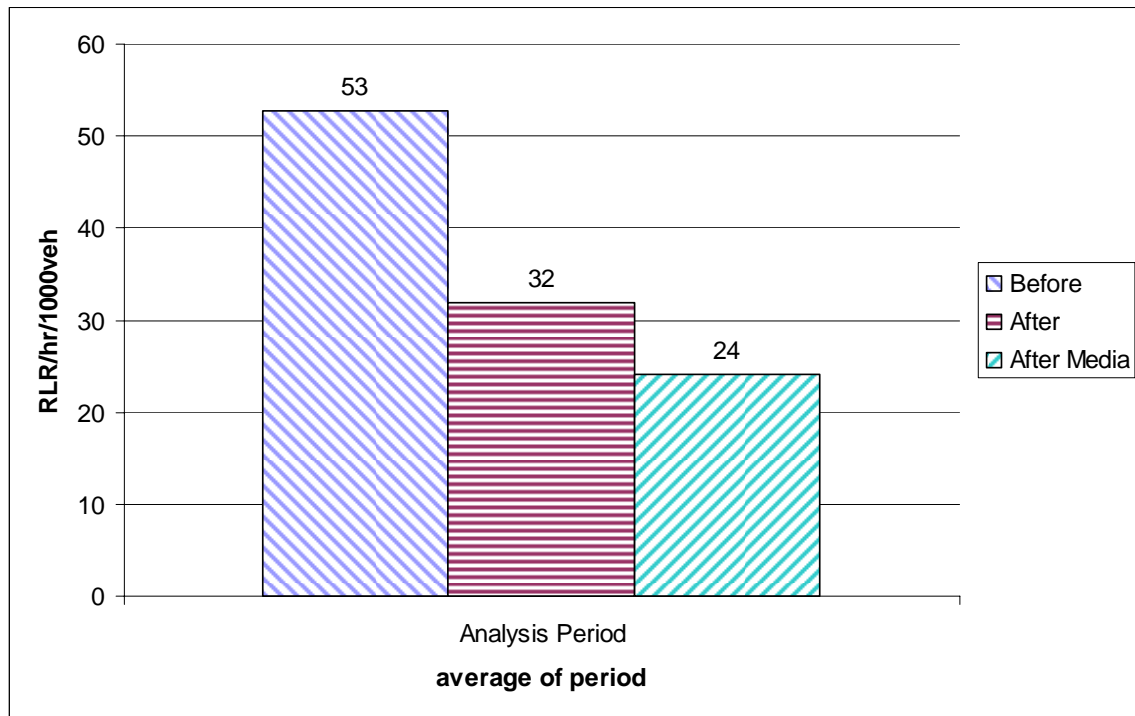

Figure 31: Average RLR rate difference for each time period

Conducting t-test for two sample assuming unequal variances of samples as in Table 14 parts (a), (b) and (c) we can conclude that the improvement after the marking installation (between “before” and “after” periods) is significant with $P\text{-value}=2.10 \times 10^{-19}$. The overall reduction in RLR rate due to the marking (between “before” and “after media” periods) is significant with $P\text{-value}=3.50 \times 10^{-38}$. The effect of the media campaign alone can be concluded significant as well with $P\text{-value}=4.77 \times 10^{-11}$.

Table 14: T-test two-sample assuming unequal variance

(a) "before" and "after" periods		
	<i>Variable 1</i>	<i>Variable 2</i>
Mean	52.77	31.87
Variance	121650.75	31232.85
Observations	27354	33555
Hypothesized Mean Difference	0	
df	38622	
t Stat	9.01249428	
P(T<=t) one-tail	1.05E-19	
t Critical one-tail	1.64	
P(T<=t) two-tail	2.10E-19	
t Critical two-tail	1.96	
(b) "before" and "after media" periods		
	<i>Variable 1</i>	<i>Variable 2</i>
Mean	52.77	24.04
Variance	121650.75	7060.72
Observations	27354	14559
Hypothesized Mean Difference	0	
df	32909	
t Stat	12.94	
P(T<=t) one-tail	1.75E-38	
t Critical one-tail	1.64	
P(T<=t) two-tail	3.50E-38	
t Critical two-tail	1.96	
(c) "after" and "after media" Periods		
	<i>Variable 1</i>	<i>Variable 2</i>
Mean	31.87	24.04
Variance	31232.86	7060.72
Observations	33555	14559
Hypothesized Mean Difference	0	
df	47751	
t Stat	6.58	
P(T<=t) one-tail	2.39E-11	
t Critical one-tail	1.64	
P(T<=t) two-tail	4.77E-11	
t Critical two-tail	1.96	

CHAPTER NINE: TRAFFIC MONITORING CAMERAS' DATA ANALYSIS

Traffic monitoring cameras collected traffic data and corresponding red light running rates every 15 min for almost one year. The data from the control intersection plus the data collected from the test intersection before the marking installation was combined to examine the traffic characteristics pertaining to the red light running phenomena. This chapter explains the data analysis and models used to explain the relation between traffic conditions and red light running.

9.1 Variables Description

Variable are summarized in Table 15, their explanation as follows;

“Number of red light runners”: number of cars that ran red light during the recording period of 15 min,

“Traffic volume”: the number of vehicles passed through the intersection during the recording period of 15 min,

“Average traffic speed”: the average speed of traffic passing through the intersection every 15 min,

“Percentage of medium vehicles”: the percentage of SUVs and pickup trucks in the total volume,

“Percentage of heavy”: the percentage of large size vehicles in the traffic,

“Percentage of heavy and medium”: combination of both medium and large size vehicles,

“Percentage of green”: percentage of time the signal is green for the traffic,

“day of the week”: week day versus weekends.

Table 15: Variables description

Variable	Unit	Variable Type
Number of red light runners	vehicle	Continuous
Traffic volume	vehicle	Continuous
Average traffic speed	mph	Continuous
Percentage of medium vehicles	-	Continuous
Percentage of heavy vehicles	-	Continuous
Percentage of heavy and medium	-	Continuous
Percentage of green time	-	Continuous
Day of the week	week day vs. week end	Categorical

9.2 General Data Trends Analysis

Collected data set consisted of 102,822 data points (rows) after filtration. Red light running incidents occurred 21.77% of the time and 78.23% the cameras did not record any red light running incidents.

9.2.1 Change of Red-light Running over the Days of the Week

From Table 16 and Figure 32 we can see that the highest day with red light running incidents was Friday, with 24.11% of the data collected having red light running incidents this can be explained by the end of the week frustration as people are more eager to get to the week end. However the shift in the percentage cannot be deemed recognizable leading to the belief that the day of the week is not a main factor affecting the red light running trends but rather it is associated with other factors that can cause variations in the trends of red light running.

Table 16: Percentage of time periods with red light running change over days of the week

day	Monday	Tuesday	Wednesday	Thursday	Friday	Saturday	Sunday
%RLR	21.82%	22.54%	22.11%	22.95%	24.11%	21.05%	17.97%

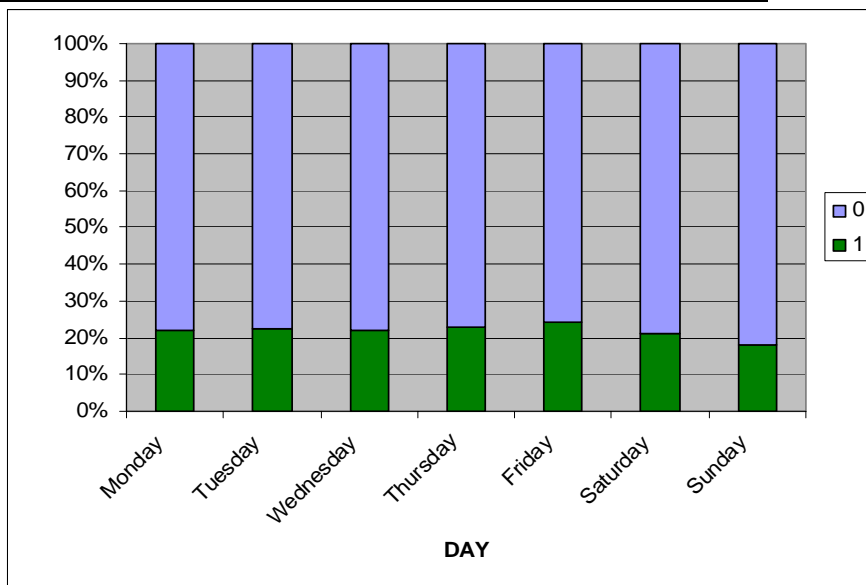
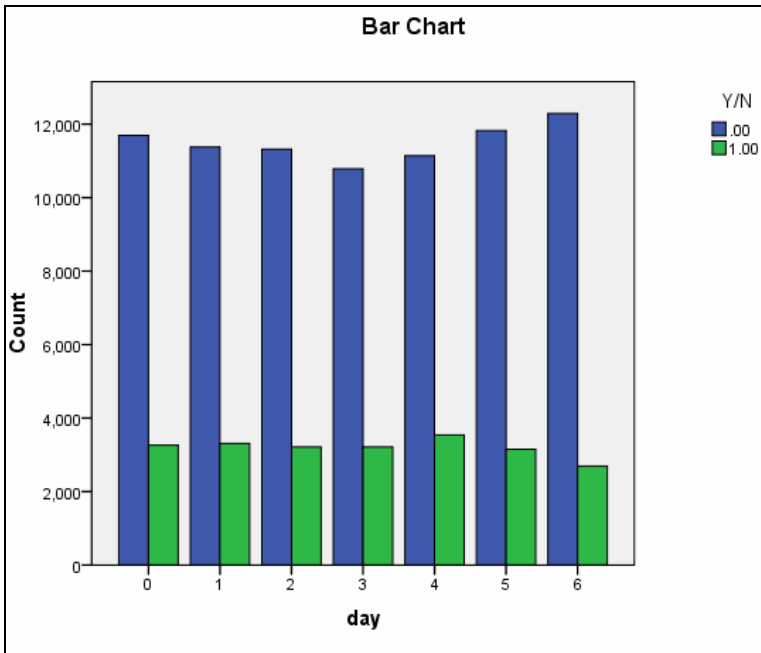

Figure 32: Red light running trends over the days of the week

9.2.2 Change of red light running between week ends and working days

The percentage of time periods that observed red light running during the working days is higher in general than the percentage during the week-end days as Table 17 and Figure

33. However because our two selected intersections are located in area near the University of Central Florida main campus the conclusions drawn from this observations should only be observed as description of red light running trends of these two particular intersections and not as a general trend of all intersections.

Table 17: Percentage of time periods with red light running change between week ends and working days

Day	Working	Weekend
%RLR	29.98%	26.12%

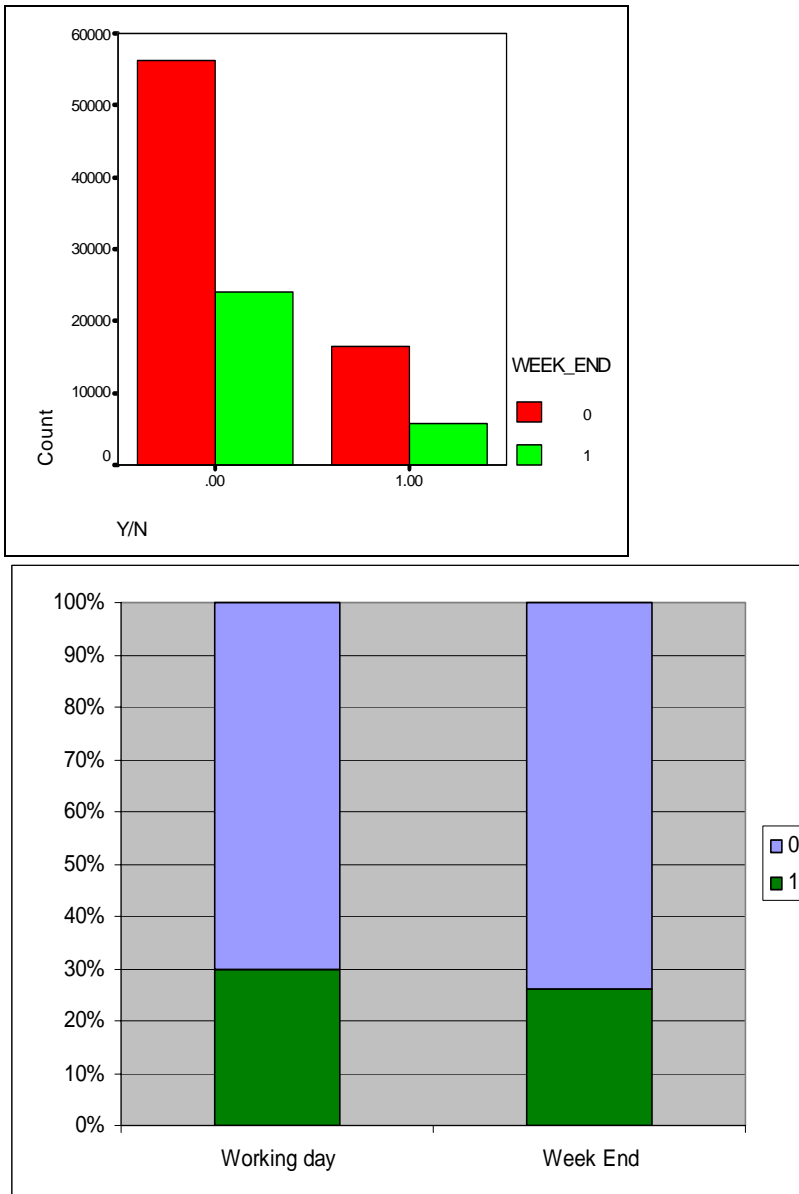

Figure 33: Red light running trends of working days vs. week end

9.3 Examined Methods of Analysis

There are several methods available for fitting models with continuous responses. Among others, multiple linear regression, regression trees, neural networks, support vector

machine (SVM) are also found practical useful in high-dimensional scenarios where many predictor variables of mixed types are involved.

9.3.1 Linear Regression Model

Linear regression assumes a linear relationship between the dependent and independent variables. Owing to its simplicity, easy interpretability, and sound theoretical treatment, linear regression has fundamental and wide applications in various fields. However, in situations where the relationship is strongly nonlinear, linear approximation may give rather unsatisfactory fit performance. For the research purpose an attempt to fit the data to linear regression model was felt as a necessary step to insure that going for a more complex modeling techniques is justified.

Table 18: Linear regression model

Model	Un standardized Coefficients		Standard Zed Coefficients	t	Sig.
	B	Std. Error	Beta		
(Constant)	41.358	1.991		20.771	0.000
LANE_ID	-2.22E-03	0.002	-0.004	-1.09	0.274
DATE	-3.06E-09	0.000	-0.064	-20.642	0.000
TIME	2.900E-03	0.000	0.018	4.636	0.000
COUNT	1.270E-03	0.000	0.174	34.455	0.000
SPEED	-2.68E-03	0.000	-0.041	-10.709	0.000
%GREEN	-0.162	0.015	-0.041	-10.768	0.000
%LAR	0.132	0.017	0.033	7.838	0.000
%HVY	6.729E-02	0.012	0.025	5.791	0.000

Adjusted R-square=0.044

The linear model parameters and coefficients is shown in Table 18, although the model found most of the factors significant but the overall poor performance of the model of R-squared less than 0.05 made exploring a non linear modeling technique an appropriate next step.

9.3.2 Classification Tree Model

Classification tree is a technique for modeling non linear relations avoiding the normal distribution of variables assumption. Figure 35 shows the model developed, the model found that the volume of the traffic is most important factor followed by the hour of the day and then the %green time as the variables importance appears in Figure 34.

The tree model, although it classified the importance of the variables, the model did not have any end node with more red light running incidents than non-red light running ones. In other words, all the pure nodes had the non-red light running dominating. This means that the model cannot explain what exactly increases the red light running rates in the traffic conditions.

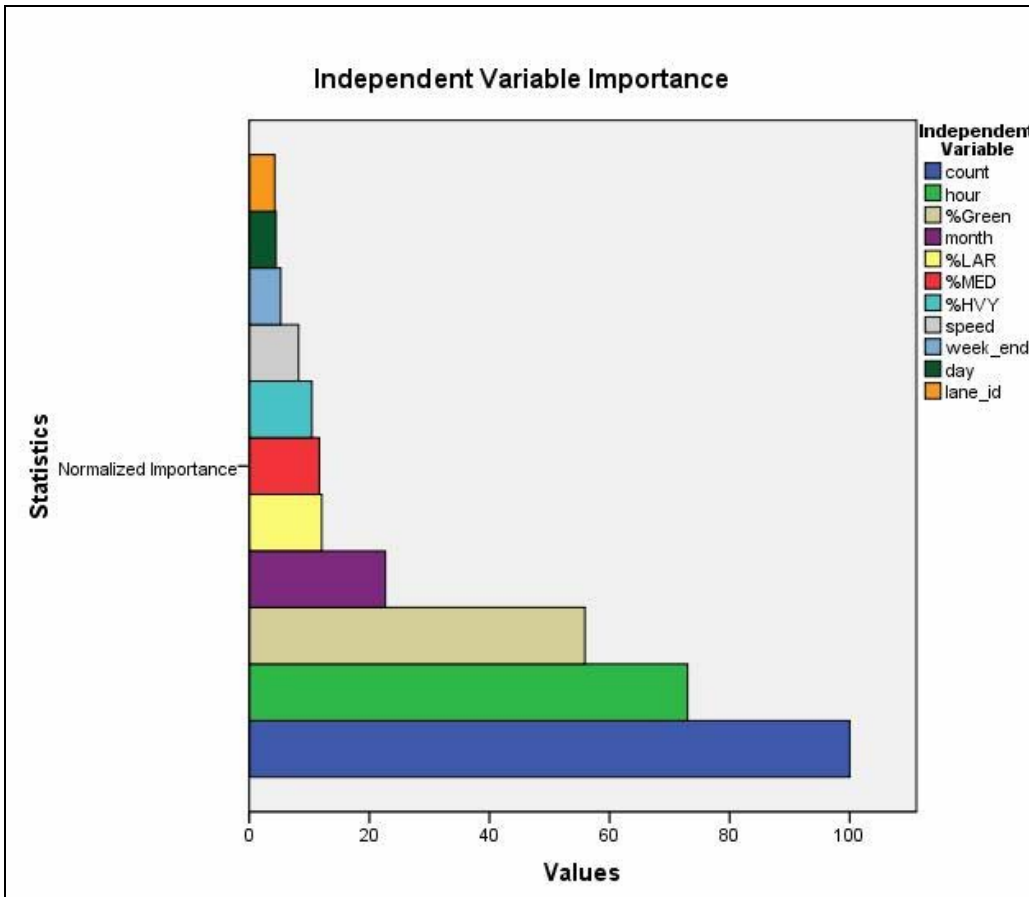

Figure 34: Variables normalized importance of the tree model

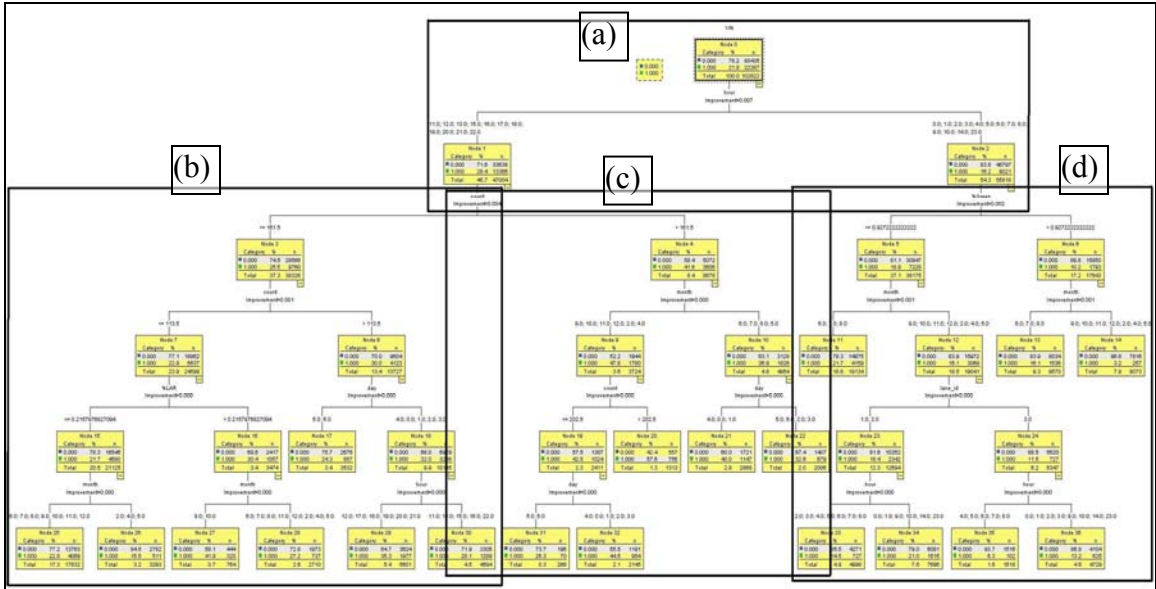

Figure 35: Red light running classification tree model

The first split variable in the classification tree is the hour of the day as shown in Figure 36. The am hours have less red light running percentages than the pm hours.

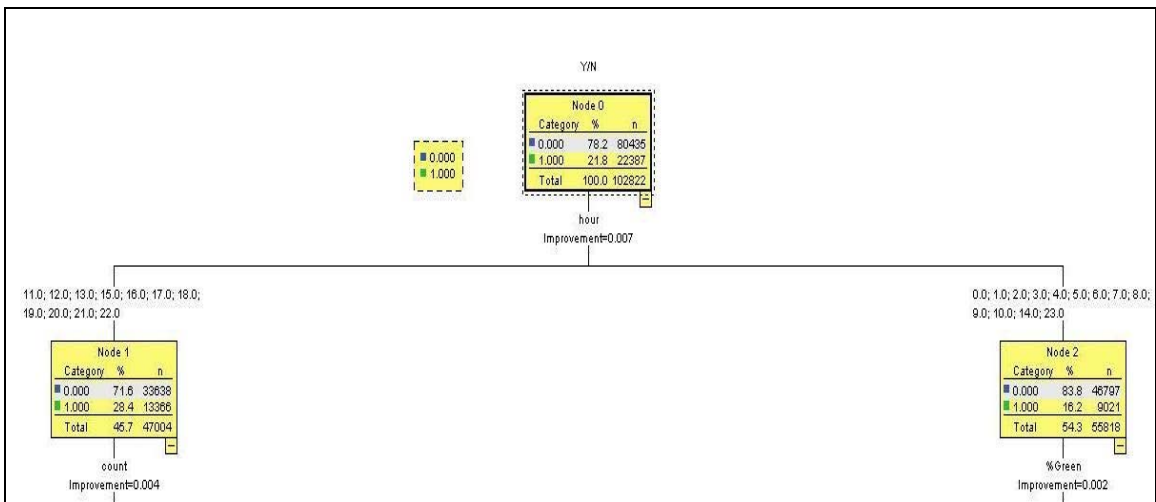

Figure 36: Part (a) of the classification tree, top portion of the tree

The second split is shown in Figure 37 is the low volume traffic, split goes through several other variables but ending with all leaves having 15%-35% red light running.

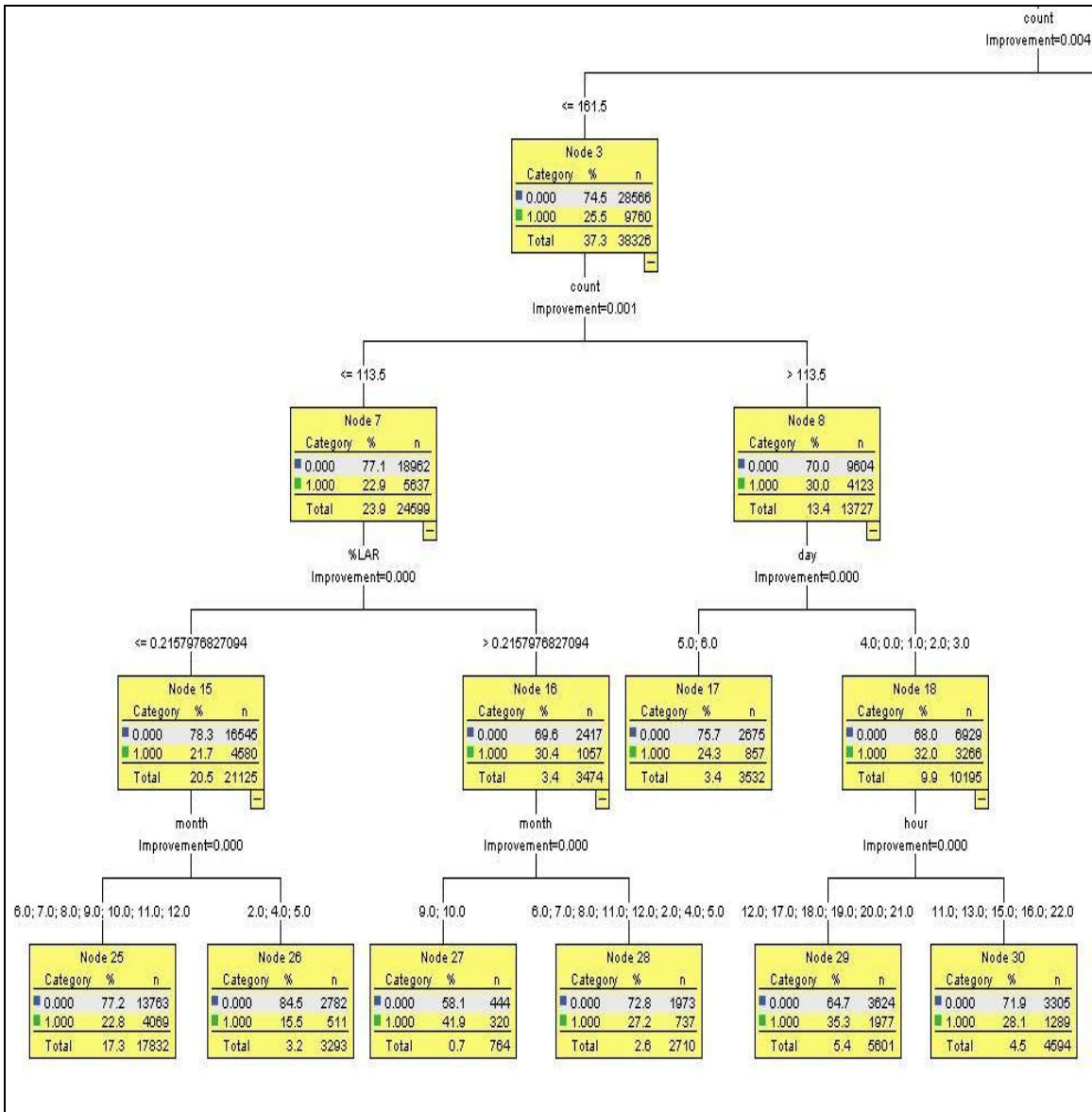

Figure 37: Part (b) of the classification tree, right portion of the tree

Figure 38 continues the second split, for high traffic volume the leaves end with red light running 30%-45%.

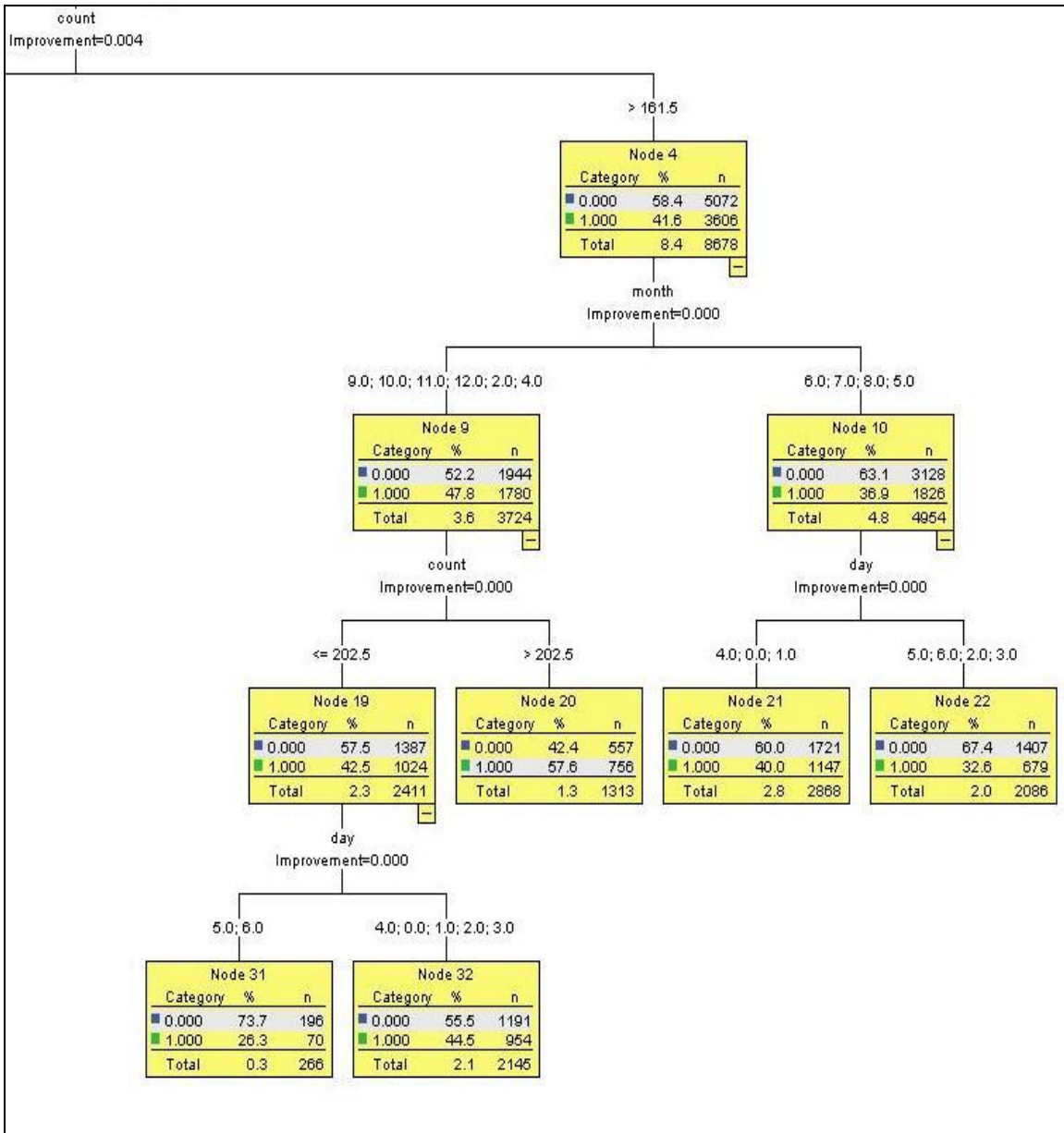

Figure 38: Part (c) of the classification tree, central part of the tree

Figure 39 shows the last portion of the tree ending with leaves 7%-15% red light running.

Although the end pure leaves had different red light running percentages, none of the leaves had red light running rate domination. This means that the model could not identify variables that can lead to high red light running rate probability.

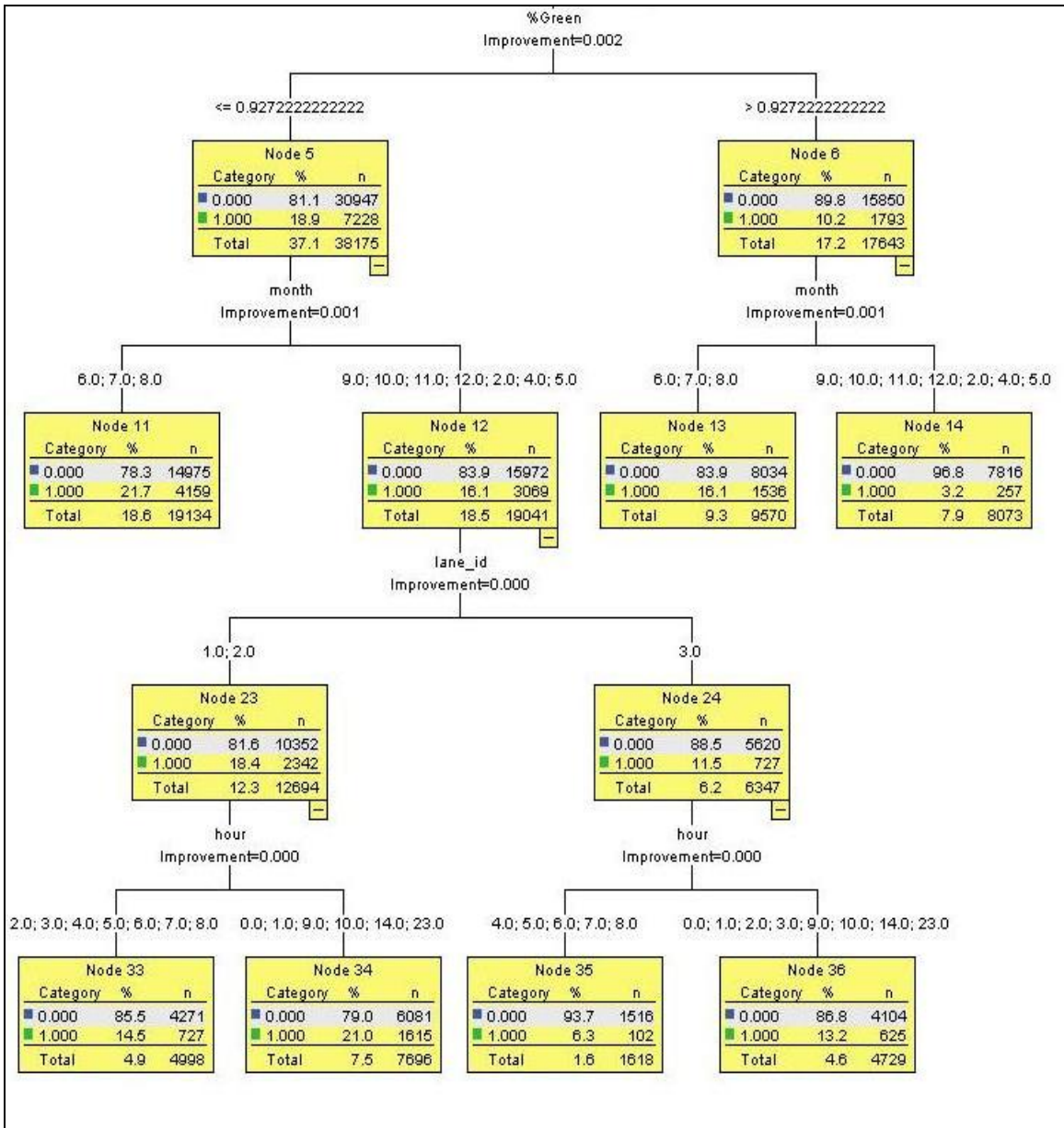

Figure 39: Part (d) of the classification tree, left part of the tree

9.3.3 Augmented Multivariate Adaptive Regression Splines (MARS)

The Augmented Multivariate Adaptive Regression Splines cumulative logit model (MARS-Augmented cumulative logit model) is an appropriate technique to analyze

participation of the traffic conditions to the red light running incidents. Multivariate Adaptive Regression Splines (*MARS*) provides a continuous broken-line approximation to the underlying regression function. It is a flexible nonparametric regression procedure with few statistical assumptions and it is able to catch nonlinear pattern and interactions and provide satisfactory prediction accuracy. Moreover, the final MARS model can be explicitly expressed and interpretation regarding effects of predictors can be extracted. Interested readers are referred to Friedman ((1991) and Friedman and Roosen (1995) for more information about this technique and how it compares to other modeling tools.

Multivariate Adaptive Regression Splines (MARS)

MARS is a nonparametric regression procedure that makes no assumption about the underlying functional relationship between the dependent and independent variables. The relationship between the continuous processing time (denoted by y^*) with all the predictors can be generally described as

$$y^* = f(x_1, \dots, x_p) + \varepsilon,$$

where f is an unspecified smooth function and ε is the random error with $E(\varepsilon) = 0$.

The multivariate adaptive regression splines makes a continuous piecewise linear approximation to f by using the basis functions of form $(x-t)_+$ and $(t-x)_+$. Here,

$$(x-t)_+ = \max(x-t, 0) = \begin{cases} x-t & \text{if } x > t \\ 0 & \text{otherwise} \end{cases} \quad \text{and} \quad (t-x)_+ = \begin{cases} t-x & \text{if } x < t \\ 0 & \text{otherwise.} \end{cases} \quad (4)$$

In conventional regression splines, they are termed as the truncated power basis functions (of first order). Each pair of such functions involves a knot at the value t .

Since $(x-t)_+ - (x-t) = (t-x)_+$, it would be equivalent if ones works with the pair $(x-t)_+$ and x instead.

The general form of MARS models can be expressed as

$$f(x_1, \dots, x_p) \equiv f(\underline{x}) = \beta_0 + \sum_{m=1}^M \beta_m B_m(\underline{x}), \quad (5)$$

Where $B_m(\underline{x})$ can be one single basis function given in equation (4) or a product of two or more such functions. Given $B_m(\underline{x})$'s, the model reduces to linear regression models, which can be directly fit by least squares. The most difficult part is how to determine the $B_m(\underline{x})$ terms in the final model.

To approach, the MARS algorithm consists of three major steps. First a large model f_\wedge is constructed with a forward selection procedure. At each step, a greedy search is performed to identify the best pair and an existing term $B(\underline{x})$ in the current model such that adding their products to the current model yields the best fit to the data. The detailed procedure is outlined in Algorithm 1 as follows:

-
- Fit model $y^* = \beta_0 + \varepsilon$, i.e., $B_0(\underline{x}) = 1$
 - Find predictor x_j and knot t_1 such that, when adding the pair $(x_j - t_1)_+$ and $(t_1 - x_j)_+$ are added, the model $y^* = \beta_0 + \beta_1 \cdot (x_j - t_1)_+ + \beta_2 \cdot (t_1 - x_j)_+ + \varepsilon$ best fits to the data.
 - Do till a large model f_Λ containing many number of basis functions is obtained.
 - Suppose that the current model contains K basis functions. Let $B(\underline{x})$ denote any one of them, including the choice $B(\underline{x}) = 1$.
 - Perform a greedy search for predictor $x_{j'}$, knot t_k , and an existing term $B(\underline{x})$, that yields the best fit to the data when terms

$$B(\underline{x}) \cdot (x_{j'} - t_k)_+ \text{ and } B(\underline{x}) \cdot (t_k - x_{j'})_+$$
 are added to the current model.
 - Update the model.
 - End Do.
-

This large model f_Λ typically over fits the data. In the second step, MARS applies a backward deletion procedure in order to determine the final model form, a task termed as *regularization* in machine learning. At each stage of the backward deletion, the term whose exclusion results in the minimal increase in the sum of squared errors is removed from the model. This leads to a nested sequence of models $\{f_\lambda : \lambda = 0, 1, \dots, \Lambda\}$, where $f_0 = \beta_0$ corresponds to the null model. Let $\{\hat{f}_\lambda : \lambda = 0, 1, \dots, \Lambda\}$ denoted the fitted model.

The third step of MARS is to select the final model from the nested sequence of models.

While many validation methods are available, MARS employs generalized cross-validation (GCV) criterion (R-statistics software algorithm was used), given as

$$GCV(\lambda) = \frac{\sum_{i=1}^n (y_i - \hat{f}_\lambda(x_i))^2}{(1 - C(\lambda)/n)^2}, \quad (6)$$

Where the effective number of degrees of freedom $C(\lambda)$ is 3 or 5 times the number of the non-constant basis functions in the model and n is the sample size. The final MARS model is the one with the smallest GCV.

The model developed using the above explained algorithm and technique results are shown in Table 19. The R-squared of the model was 0.25 which can be considered high comparing to 0.044 of linear regression. The model yielded four factors that have significant effect pertaining to red light running. These factors are:

X_1 =Traffic Volume

X_2 =Average Speed

X_3 =Per. Time Green

X_5 =Per. Large veh.

Table 19: Red light runing MARS model

	pred1	knot1 (t)	pred2	knot2(t)	Coefs(β)	SE	t-value	$\beta(X-t)_+$
	0	NA	0	NA	20.1772	0.11399	177.0084	
BF1	X_3	NA	0	NA	-75.2472	0.772435	-97.4156	= -75.2472 X_3
BF2	X_3	0.253333	0	NA	100.4728	1.951841	51.4759	= 100.4728 (X_3 -0.253333)
BF3	X_1	NA	0	NA	0.0008	0.00012	6.767192	= 0.0008 X_1
BF4	X_3	0.312222	0	NA	-26.2855	1.555768	-16.8955	= -26.2855 (X_3 -0.312222)
BF5	X_1	168	0	NA	0.0066	0.000449	14.78508	= 0.0066 (X_1 -168)
BF6	X_5	NA	0	NA	-0.6888	0.097219	-7.08519	= -0.6888 X_5
BF7	X_1	NA	X_5	NA	0.0143	0.000869	16.46157	= 0.0143 $X_1 * X_5$
BF8	X_3	0.816667	0	NA	2.3728	0.288495	8.224796	= 2.3728 (X_3 -0.816667)
BF9	X_5	0.153061	0	NA	0.7219	0.115744	6.236883	= 0.7219 (X_5 -0.153061)
BF10	X_2	NA	0	NA	-0.1237	0.009606	-12.8804	= -0.1237 X_2
BF11	X_2	15	0	NA	0.1217	0.009684	12.56897	= 0.1217 (X_2 -15)
BF12	X_3	0.872222	0	NA	-2.1204	0.343761	-6.16824	= -2.1204 (X_3 -0.872222)

R-squared=0.25

The model shows non-linear relations between the red light running and the traffic speed, also there is a significant non-linear relation between the percentage of green time and the red light running, but the model shows a complex relationship between the traffic volume and the percentage of heavy vehicles on one side and the red light running on the other side. This means that the relation is non linear and there is an interaction between the traffic volume and the percentage of heavy truck.

The equation in the model that describes the relation between volume, heavy vehicle and the red light running is:

$$f(X1, X5)=0.0008X1+0.0066(X1-168)+0.0143(X1*X5)-0.6888X5+0.7219(X5-0.153061)$$

The equation is better interpreted through a graphical plot. The equation was plotted in 3 dimensions, plots Figure 40 and Figure 41 show the relation from two different angles.

The plot shows that the red light running is at its maximum with heavy traffic and large percentage of heavy vehicles, but one can observe that when the volumes are very low the increase in the heavy vehicle percentage tends to decrease the red light running this can be better observed from Figure 41, while the increase of heavy vehicle percentage in heavier traffic tends to increase the red light running.

Following observations can be made:

- Light traffic conditions with low heavy vehicle percentages the red light running is very low.
- Increase in heavy vehicle percentage in low traffic conditions reduces the number red light running.
- As the traffic volume increases the percentage of heavy trucks tends to reverse the trend. Instead of reducing red light running it increases it.

It is speculated that heavy truck traffic tends to have two possible effects, first it might increase frustration to motorists, and second it blocks the vertical view of the car driving behind it too closely. These two effects can explain the interaction between the volume of traffic and the percentage of heavy vehicles. Because in low traffic volumes and high heavy traffic conditions you get less chance of small vehicles getting stuck behind a larger vehicle thus fewer vehicles with obstructed view. Alternatively, when traffic volume increases, the probability of red light running increases. Having a high percentage of heavy traffic increases the chance of a small vehicle getting stuck behind a heavy vehicle and the increase in red light running reflects the frustration and sight obstruction effect on the red light running.

It is also hypothesized that the decrease in the red light running in low traffic conditions with high heavy vehicle percentage can be attributed to the more careful behavior of the heavy vehicles drivers specially that they are required to keep higher safety standards to maintain their commercial driving license. One more thing to be added and this is the two

intersections used in this study are located near the University of Central Florida main campus and there is a number of K-12 schools in the area. It is possible that some of the vehicles classified as heavy vehicles by the cameras can be school buses and their drivers tend to be extra careful drivers, meaning that if the study was conducted on or near a heavy commercial or industrial area we may find different red light running trends at low volume and high heavy traffic conditions.

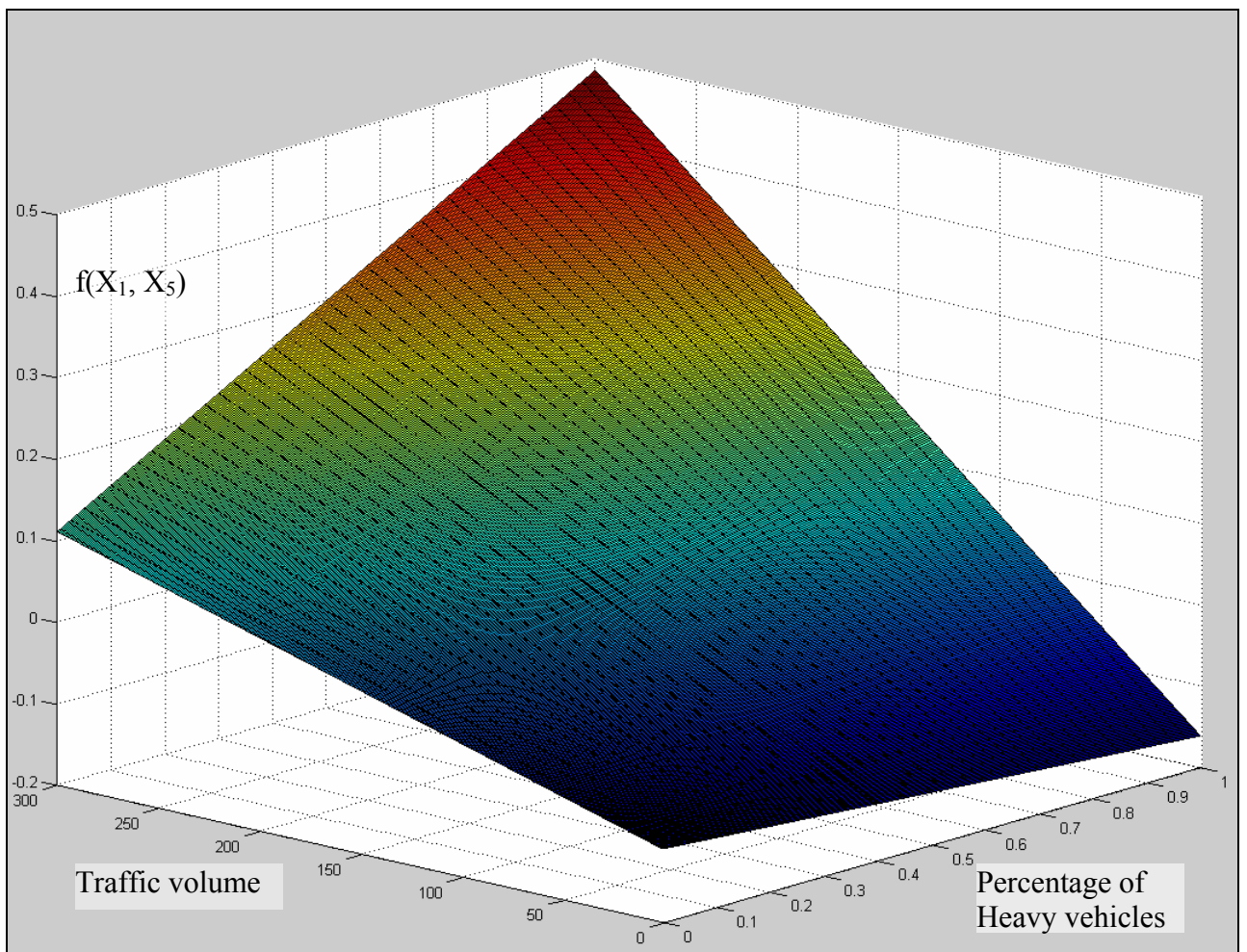

Figure 40: Relation between traffic volume-Heavy vehicles and red light running

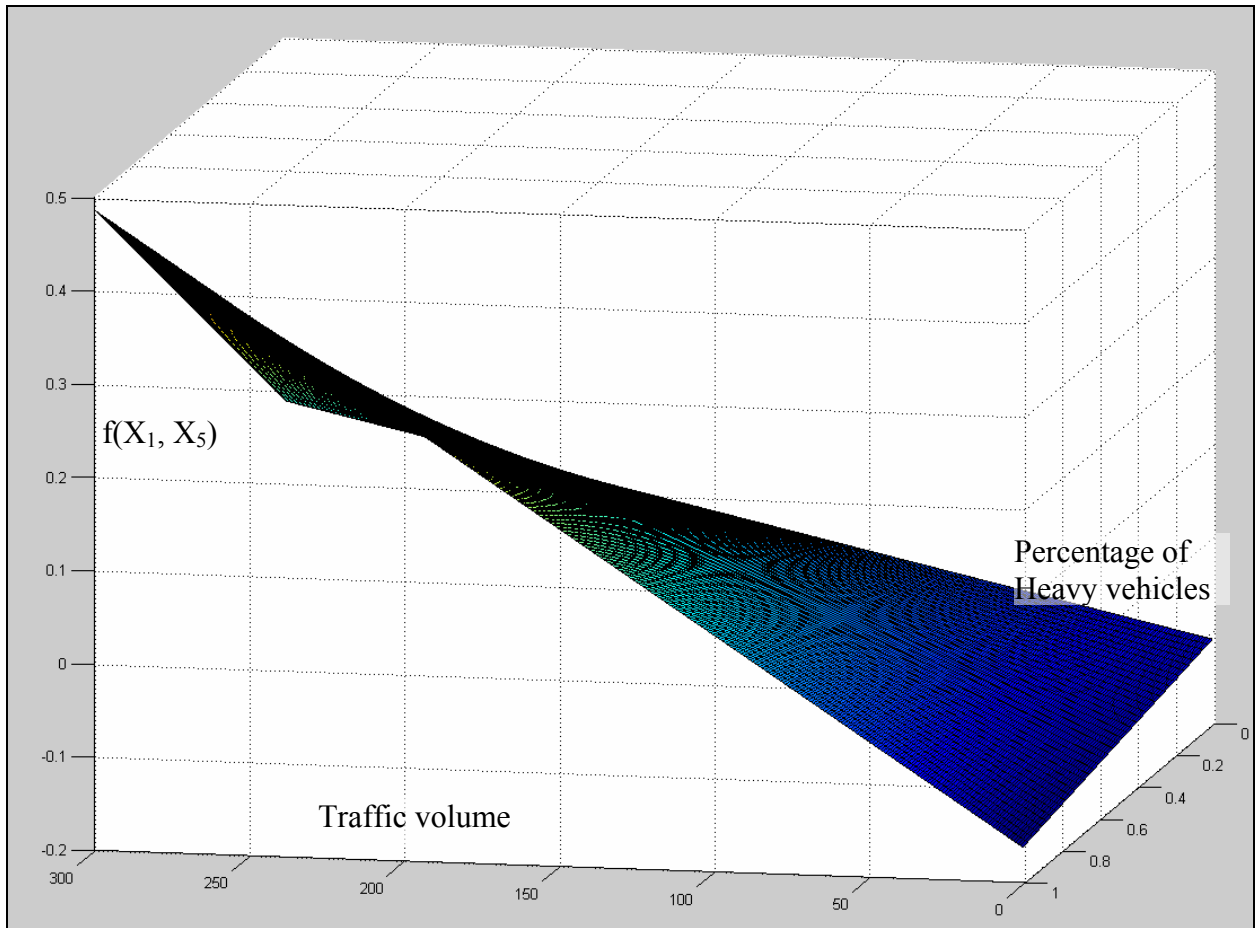

Figure 41: Relation between traffic volume-Heavy vehicles and red light running different angle plot

The relation between the average traffic speed and the red light running in the model represented by:

$$f(X_2) = 0.1217 (X_2-15)_+ -0.1237 X_2$$

The relation is plotted in Figure 42 and it can be observed that as the average speed of the traffic increase the red light running decrease. This agrees with the findings of the behavior study that indicated that vehicles running above the speed limit have fewer tendencies to run red light because they can reach the stop bar faster.

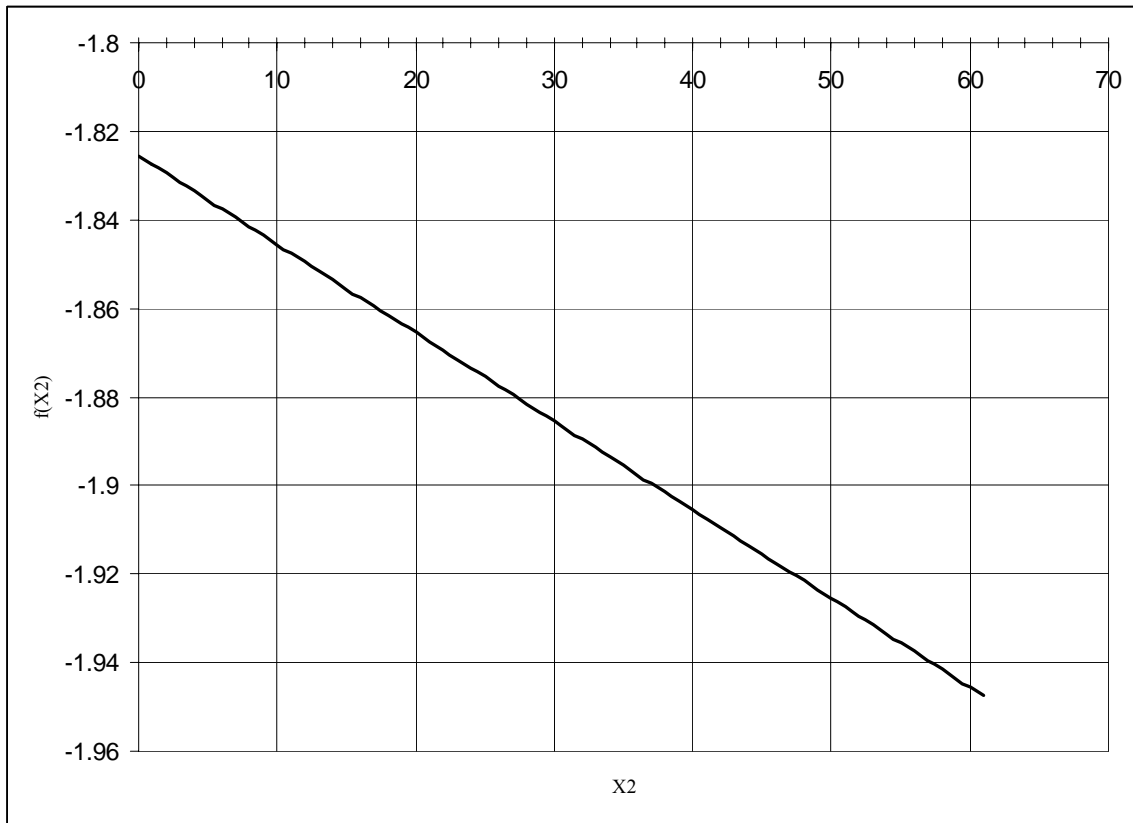

Figure 42: Relation between traffic speed and red light running

The relation between the percent of green time and the red light running in the model represented by:

$$f(X_3) = -75.2472 X_3 + 100.4728 (X_3 - 0.253333)_+ - 26.2855 (X_3 - 0.312222)_+ + 2.3728 (X_3 - 0.816667)_+ - 2.1204 (X_3 - 0.872222)_+$$

The relation is plotted in Figure 43 and it can be observed that as the percent of time the signal stays green increases the red light running decrease. This can be explained by the exposure factor. The increase in green time means fewer interruptions by cross traffic and thus fewer vehicles encountering the yellow change.

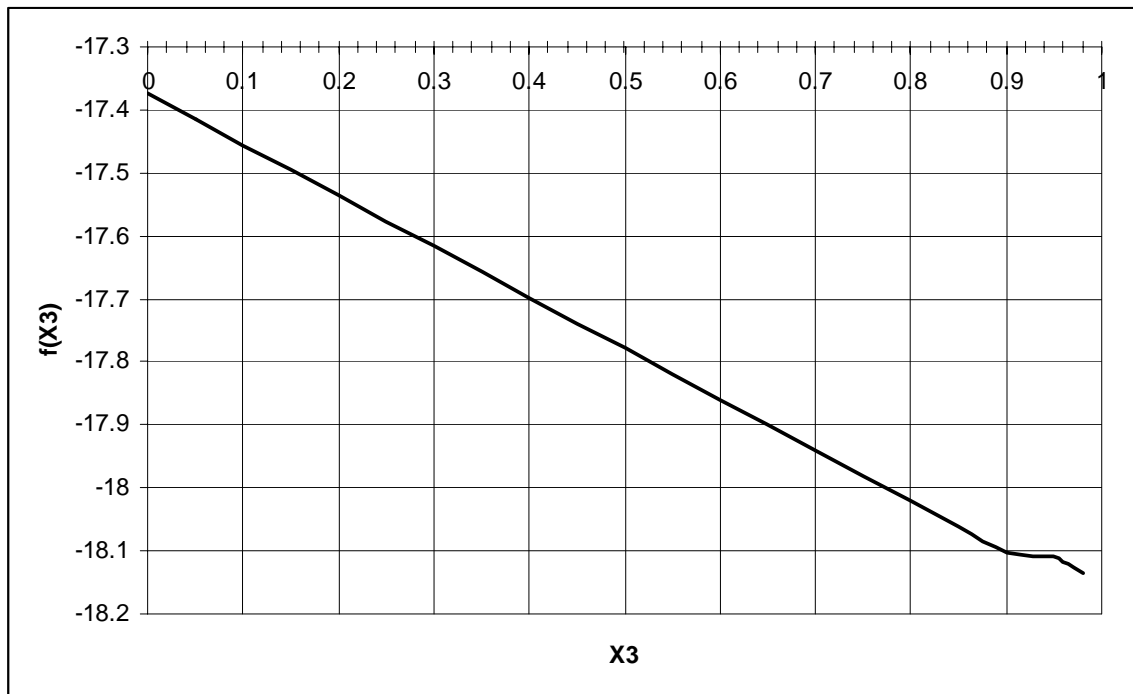

Figure 43: Relation between percentage green time and red light running

CHAPTER TEN: SUMMARY CONCLUSION AND RECOMMENDATIONS

10.1 Research Work Summary

This research aimed to explore the red light running phenomena and offer a better understanding of the factors associated with it. The red light running is a type of traffic violation that can lead to angle crash and the most common counter measure is installing a red light running cameras. Red light running cameras some time can reduce the rates of red light running but because of the increased worry of the public towards crossing the intersection it can cause an increase in rear end crashes. Also the public opinion of the red light running cameras is that they are a revenue generator for the local counties and not a concern of public safety. Furthermore, they consider this type of enforcement as violation of privacy.

There was two ways to collect the data needed for the research. One way is through a tripod cameras setup temporarily placed at the intersection. This setup can collect individual vehicles caught in the change phase with specific information about their reactions and conditions. This required extensive manual analysis for the recorded videos plus data could not be collected during adverse weather conditions. The second way was using traffic monitoring cameras permanently located at the site to collect red light running information and the simultaneous traffic conditions. This system offered more extensive information since the cameras monitor the traffic 24/7 collecting data directly. On the other hand this system lacked the ability to identify the circumstances associated

with individual red light running incidents. The research team finally decided to use the two methods to study the red light running phenomena aiming to combine the benefits of the two systems.

During the research the team conducted an experiment to test a red light running countermeasure in the field and evaluate the public reaction and usage of this countermeasure. The marking was previously tested in a driving simulator and proved to be successful in helping the drivers make better stop/go decisions thus reducing red light running rates without increasing the rear-end crashes.

The experiment was divided into three phases; before marking installation called “before”, after marking installation called “after”, and following a media campaign designed to inform the public about the use of the marking the third phase called “after media”

10.2 Research Findings

The behavior study that aimed at analyzing the motorist reactions toward the signal change interval identified factors which contributed to red light running. There important factors were:

- Distance from the stop bar,
- Speed of traffic
- Leading or following in the traffic

- Vehicle type

It was found that a driver is more likely to run red light following another vehicle in the intersection. Also the speeding vehicles can clear the intersection faster thus got less involved in red light running violations.

The proposed “Signal Ahead” marking was found to have a very good potential as a red light running counter measure. The red light running rates in the test intersection dropped from 53 RLR/hr/1000veh for the “before” phase, to 24 RLR/hr/1000veh for the “after media” phase. The marking after media analysis period found that the marking can help the driver make stop/go decision as the dilemma zone decreased by 50 ft between the “before” and the “after media” periods.

Analysis of the traffic condition associated with the red light running it revealed that relation between the traffic conditions and the red light running is non-linear, with some interactions between factors. The most important factors included in the model were:

- Traffic volume,
- Average speed of traffic,
- The percentage of green time,
- The percentage of heavy vehicles,
- The interaction between traffic volume and percentage of heavy vehicles.

The most interesting finding was the interaction between the volume and the percent of heavy vehicles. As the volume increased the effect of the heavy vehicles reversed from reducing the red light running to increasing the red light. This finding may be attributed to the sight blocking that happens when a driver of a passenger car follows a larger heavy vehicle, and can be also explained by the potential frustration experienced by the motorist resulting from driving behind a bigger vehicle.

10.3 Future Research Suggestions

The following research can test the suggested marking further to try different intersections geometric setups, speed limits and traffic type zones (semi-rural or CBD for example). The marking proved to have a good potential as a red light running counter measure but needs to be tested in larger number of intersections with more control intersections.

The sight blockage issue caused by driving behind larger vehicle need to be examined further to develop possible counters measures aimed to further reduce the red light running.

LIST OF REFERENCES

- Abdel-Aty, M., Lee, C., Wang, X., Nawathe, P., Keller, J., Kowdla, S., Prasad, H., 2005, *Identification of intersections' crash profiles/patterns*, FDOT Final Report.
- Baugley, C. J., 1988, *Running the Red at Signals on High-Speed Roads*, Traffic Engineering Control, Vol. 29, pp. 415–420.
- Bonneson, J., Brewer M., and Zimmerman, K., 2001. *Review and Evaluation of Factors that Affect the Frequency of Red Light-Running*, FHWA/TX-02/4027-1, Washington, DC, Federal Highway Administration.
- Bonneson, J.A., Zimmerman, K.H., and Brewer, M.A., 2002. *Engineering Countermeasures to reduce red-light-running*, Research report 4027-2. Texas Transportation Institute, college station, TX. August 2002.
- Breiman L., Friedman J.H., Olshen R.A. and Stone C.J, 1984, *Classification and regression Tree*, Chapman and Hall.
- Bryan E. Porter and Thomas D. berry, 2001, *A Nationwide Survey of Self-Reported Red Light Running: measuring prevalence, predictors, and Perceived Consequences*, Accident Analysis and prevention Vol. 33, .2001.
- Christopher M. Cunningham and Joseph S. Hummer, 2004. Evaluating the use of red light photographic enforcement using collisions and red light violations final report. Institute for Transportation Research and Education, North Carolina State University, 2004.
- Council, F. M., Persaud, B., Eccles, K., Lyon, C., and Griffith, M. S, *Safety Evaluation of Red Light Cameras*, Report No.: FHWA-HRT-05-048/ HRDS-02/04-05(500)E, Federal Highway Administration, Washington, D.C. 2005.

- David Andreassen, 1995. A long term study of red-light cameras and accidents.
Australian Road research Board, February 1995.
- Eric J. Fitzsimmons, Shauna Hallmark, Thomas McDonald, Massiel Orellana, and David Matulac, 2007. The Effectiveness O Iowa's automated red light enforcement program final report. Center of Transportation and Education Iowa State University, December 2007.
- Federal Highway Administration. Guidance for using red light cameras. National Highway Traffic Safety Administration February 2003.
- Federal Highway Administration (FHWA), Website:
http://safety.fhwa.dot.gov/fourthlevel/pro_res_srlr_facts.htm, access date, Aug 2003
- Federal Highway Administration (FHWA), 2003. *Making Intersection safer: A Toolbox of Engineering Countermeasures to Reduce Red-light Running*, Institute of Transportation Engineers. ISBN: 0-935403-76-0.
- Friedman, J. H. (1991). "Multivariate Adaptive Regression Splines" (with discussion). *Annals of Statistics* 19, 1-142.
- Friedman, J. H. and Roosen, C. B. (1995). An introduction to multivariate adaptive regression splines. *Statistical Methods in Medical Research*, 4(3): 197-217.
- Hesham Rakha, Ahmed Amer and Ihab El-Shawarby, *Modeling Driver Behavior within a Signalized Intersection Approach Decision-Dilemma Zone*, Transportation Record: Journal of Transportation Research, Volume 2069, 2008.
- Kagwon Shin and Simon Washington, 2007. The impact of red light cameras on safety in Arizona. *Accident Analysis and Prevention* issue 39 2007.

- Making Intersections Safer, a Tollbox of Engineering Countermeasure to Reduce red light Running*, Federal Highway Administration and Institute of transportation Engineers, information report 2003.
- Martinez K.L. and Porter B.E., 2006, *Characterizing red light running Following Implementation of a Photo Enforcement Program*, Accident Analysis and Prevention, volume 38(5):862-70.
- National Highway Traffic Safety Administration, 2006. *Traffic safety facts 2004: a compilation of motor vehicle crash data from the fatality analysis reporting system and the general estimates system*, 2004 Final Edition. Washington, DC.
- Newton, C., Mussa, N. R. Sadalla, K. E., Burns, K. E, and Matthias, J., 1997, *Evaluation of an alternative traffic light change anticipation system*, Accident Analysis & Prevention, Vol. 29, pp. 201-209.
- Nicholas J. Garber, John S. Miller, R. Elizabeth Abel, Saeed Eslambolchi and Santhosh K. Korukonda, 2007. *The Impact of red light cameras (photo-red enforcement) on crashes in Virginia final report*. Virginia Transportation Research Council June 2007.
- Office of the Majority Leader, 2001. *The Red Light Crisis, Is it International?*. U.S. House of Representatives May 2001.
- Pnagiotis Papaioannou, 2006, *Driver Behavior, Dilemma Zone and Safety Effects at Urban Signalized intersections in Greece*, Accident Analysis and prevention, 2006.
- Porter, B. E. and England, K.J., 2000. *Predicting Red-Light Running Behavior: A Traffic Safety Study in Three Urban Settings*, Journal of Safety Research, Vol. 31, pp. 1-8.

- Quiroga, C., Karaus, E., Schalkwyk, I.V., and Bonneson, J., 2003, *Red Light Running- A policy review*, CTS-02/150206-1, March 2003.
- Retting A. R. et al, 1995, *Classifying Urban Crashes for Countermeasure Development*, Accident Analysis and prevention Vol. 27.
- Retting R.A. and Allan F. Williams, 1996. *Characteristics of Red Light Violators: Results of a Field Investigation*, Journal of Safety Research, Vol. 27, No. I, pp. 9-15, 1996
- Retting, R.A., Greene, M.A., 1997. *Influence of signal timing on red-light running and potential vehicle conflicts at intersections*. Transportation Research Record 1595, 1-7.
- Retting R.A. et al, 1999, *Prevalence and Characteristics of red Light Crashes in the United States*, Accident Analysis and Prevention Vol. 31, 1999
- Retting, R.A., Chapline, J.F., and Williams, A.F., 2002. *Changes in Crash Risk Following re-timing of Traffic Signal Change Intervals*, Accident Analysis & Prevention, Volume 34, pp. 215-220.
- Retting R.A. and Susan A. Ferguson, 2003. *Effects of Red Light Cameras on Violations and Crashes: A Review of the International Literature*, Traffic Injury Prevention, Vol. 4 pp. 17-23.
- Sayed, T., Vahidi, H., and Rodriguez, F., 1999. *Advanced Warning Flashers: Do They Improve Safety?*, Transportation Research Record 1692, Washington, DC: Transportation Research Board, 1999.
- Smith, T., 2001. *Effects of Advanced Warning Flashers at Signalized Intersections on Simulated Driving Performance*, Advanced Transportation Technologies Seminar

- Series, Fall 2001,
<http://www.its.umn.edu/Events/SeminarSeries/2001/Fall/Articles/Smith.html>
, Access date, Jul 2007.
- Tarek M. Tarawneh and Mohammed S. Tarawneh, 2002. *Compliance and Comprehension of the Yellow Signal Indication: A Case Study from Jordan*, Traffic Injury Prevention, Vol. 3, pp. 298-302.
- The Red Light Running Crisis: Is it Intentional?*, Office of the Majority Leader, U.S. house of Representatives, May 2001.
- Time J. Gates, David A. Noyce, Luis Laracuenta and Erik V. Nordheim, Analysis of Behavior in Dilemma Zone at signalized Intersections, Transportation Record: Journal of Transportation Research, Volume 2030, 2007.
- Traffic Detector handbook: Third Edition-Volume I*, Federal Highway Administration, Publication number FHWA-HRT-06-108, October 2006.
- Traffic National Committee on Uniform Traffic Laws and Ordinances, *Uniform Vehicle Code and Model*.
- Washburn, S.S., and Courage, K.G. 2004, *Investigation of Red light Running Factors*, Southeast Transportation Center, University of Tennessee, Knoxville, Tennessee.
- Xuesong Wang and Mohamed Abdel-Aty, 2006. *Temporal and spatial analyses of rear-end crashes at signalized intersections*. Accident Analysis & Prevention, In Press, Corrected Proof, Available online 13 June 2006.
- Yan, X., Radwan, E. and Birriel, E., 2005. *Analysis of Red-light Running Crashes Based on Quasi-induced Exposure and Multiple Logistic Regression Method*. Transportation Research Record 1908. pp. 70-79.

Yan, X., Radwan, E. and Abdel-Aty, M., 2005. *Characteristics of rear-end accidents at signalized intersections using multiple logistic regression model*. Accident Analysis & Prevention, Vol. 37, pp. 983-995.

Yusuf M. Mohamedshah, Li Chen and Forrest M., *Association of selected intersection factors with red-light-running crashes*, Highway safety information system (HSIS) Summary report, FHWA-RD-00-112, May 2000.

Zegeer, C., *Effectiveness of green-extension systems at high-speed intersections*, Kentucky Department of Transportation, Research Report 472, 1977.