

STARS

University of Central Florida
STARS

Retrospective Theses and Dissertations

Fall 1981

An Evaluation of a Visual Training Technique for Female Volleyball Players

Diane G. Burbank
University of Central Florida

 Part of the [Industrial and Organizational Psychology Commons](#)
Find similar works at: <https://stars.library.ucf.edu/rtd>
University of Central Florida Libraries <http://library.ucf.edu>

This Masters Thesis (Open Access) is brought to you for free and open access by STARS. It has been accepted for inclusion in Retrospective Theses and Dissertations by an authorized administrator of STARS. For more information, please contact STARS@ucf.edu.

STARS Citation

Burbank, Diane G., "An Evaluation of a Visual Training Technique for Female Volleyball Players" (1981). *Retrospective Theses and Dissertations*. 541.
<https://stars.library.ucf.edu/rtd/541>



AN EVALUATION OF A VISUAL TRAINING
TECHNIQUE FOR FEMALE VOLLEYBALL PLAYERS

BY

DIANE G. BURBANK
B.A., University of Central Florida, 1979

THESIS

Submitted in partial fulfillment of the requirements
for the Master of Science degree in Industrial Psychology
in the Graduate Studies Program of the College of Arts and Sciences
University of Central Florida
Orlando, Florida

Fall Term
1981

Acknowledgments

I would like to express my appreciation to my committee members, Dr. Jack McGuire and Dr. Edwin Shirkey and to Dr. Marc Sherman, visual training therapist, for their time and suggestions. I would also like to express my gratitude to my committee chairman, Dr. Wayne Burroughs for his patience, interest, kindness, and advice, not only during the course of this study, but throughout my graduate career.

I am especially grateful to the University of Central Florida women's volleyball coach, Carmen Pennick, and the young women of the U.C.F. volleyball team, for their cooperation and enthusiasm and for making this study possible.

I want to express thanks to Dennis Nichols for his time, interest, and suggestions, particularly in regard to the visual training apparatus used for this study.

Finally, I want to acknowledge the University of Central Florida Library and its librarians who I found to be competent, fast, and always courteous to those who come to them for help.

Table of Contents

	Page
List of Tables	v
Introduction	1
Method	9
Results	15
Discussion	21
Appendices	
A. Background Information	25
B. Peripheral Vision Enhancement Training Device	27
C. Training Data Sheet	29
D. Peripheral Vision Test Score Sheet	31
E. Peripheral Vision Test Placement Sheet	34
F. Peripheral Vision Test Scoring Instructions	37
G. Participant's Evaluation Form	39
H. Samples of Positive, Neutral, and Negative Comments from the Participant's Evaluation Questionnaire	42
Reference Notes	46
References	48

List of Tables

Table	Page
1. Demographic Breakdown of Experimental and Control Groups	10
2. Peripheral Vision Posttest Results for Experimental and Control Groups	16
3. Peripheral Vision Posttest Results for Top Third and Bottom Third Experimental Group . .	17

Introduction

Visual Skills and Athletic Performance

The relationship between optimal visual skills and optimal athletic performance is becoming increasingly popular with physical educators in the United States. An ongoing program of optometric participation has been established by the United States Olympic team at their Olympic Training Centers in Colorado Springs, Colorado and Squaw Valley, California (Sherman, 1980). At the National Sports Festival in July 1979, the American Optometric Association participated in a three day visual screening of prospective Olympic athletes. At this screening, results indicated that as many as 60% of these athletes could improve their eye-hand coordination by improving their visual acuity (Parker, 1980).

Research studies show significant correlations between athletic performance and certain visual attributes. In a review of Russian studies of vision in relation to sports (Graybiel, Jokl, & Trapp, 1955), a significant correlation was found between athletic efficiency of tennis and soccer players and their depth perception. Moreover, the more skillful players perceived depth more accurately than the less skillful players. In the Russian studies of javelin

and discus throwers, it was observed that when peripheral vision was blocked, there was poorer performance in distance of throw and coordination of movement. Also, peripheral vision measured before and after motor performance indicated an increase in peripheral field after the performance. Athletes tested before and after a 1000-meter race showed an increase in visual acuity of as much as 45% in 73% of the athletes (27% remained unchanged). The greatest sharpness was found immediately (within 10 minutes) after the competition (Graybiel et al., 1955). In a more recent study, Trachtman (1973) discusses the relationship between ocular motilities and batting averages of Little League baseball players. A highly significant correlation was observed between ocular motility and the batting average of the players. Beals, Mayyosi, Templeton, and Johnston (1971) studied correlations between basketball shooting accuracy and dynamic visual acuity (the ability to discriminate an object when there is relative movement between the observer and the object), static (or standard) visual acuity, depth perception (perception of the relief of objects in which they appear to be in three dimensions rather than as flat objects), and size constancy. They found a significant correlation existing between the basketball players' dynamic visual acuity scores and their field goal shooting average. It was concluded that the

ability of the player to shoot baskets from the field was highly dependent on dynamic visual acuity.

Visual Skills of Athletes and Non-Athletes

The relationship between vision and athletic performance is further strengthened by studies comparing the visual skills of athletes and non-athletes. Olsen (1956) studied three groups of college males designated as athletes, intermediates, and non-athletes who were given tests designed to measure reaction time, depth perception, and span of apprehension (the number of objects that can be recognized in a single fixation of the eye to permit immediate report of what has been seen). Analysis of the test data revealed significant differences between the three groups. Athletes were found to be superior to non-athletes in all tests and superior to intermediate athletes in reaction time. Stroup (1957) compared the "field of motion perception" of basketball players and non-basketball players. Five skill test items and their scores on these items and the visual measurements were compared with basketball ability rating scores. Visual measurements showed a relationship with basketball ability, and when combined with test items, "made a substantial contribution to the forecasting efficiency of the battery" (p. 76). In a study of the relationship between selected sport skills in soccer, basketball, volleyball, and baseball of junior high school boys and the psychological tests, reaction time,

depth perception, and peripheral vision, Ridini (1968) found that athletes had significantly better peripheral fields, depth perception and faster reaction time. Williams and Thirer (1975) found that both vertical and horizontal peripheral visual fields were superior for athletes as compared to non-athletes.

Vision Training and Sports

The role of vision in sports and the need for visual training of athletes is supported in the optometric literature.

Preciseness of eye muscle coordination from inner-vational patterns leads to precision of movements allowing the organism maximum sensory input to get the information necessary to perform the task. (Pitts, 1974, p. 11)

Although most collegiate and professional athletes have good visual abilities or they would not be successful athletes, optometrists report 15-28% of athletes fail general visual screening standards (Bauscher, 1968; Bennett, 1979; Garner, 1977; Martin, 1968). Martin (1968) reports the results of the first visual program for the Boston Red Sox baseball team in 1964. Of 135 players receiving complete vision examinations, 18% failed. Thirteen players needed glasses for the first time, six needed their prescriptions increased and five had a high degree of muscle imbalance and lack of depth perception.

Even athletes with adequate vision can be taught to have superior visual skills and better performance will result (Getz, 1978). All the necessary visual abilities for sports are trainable and enhanceable by visual training (Getz, 1978; Parker, 1980; Sherman, 1980). Studies of effects of vision training show promising results. Harrison (1977) taught baseball players to see the ball better using visual training techniques such as "pursuit fixations." He also used on-the-field tips such as watching the release zone of pitchers, concentrating on the middle of the ball, and centering on the ball with minimal peripheral awareness. Revien (cited in Sherman, 1980) reports the results of a visual training program for the New York Sandlot Baseball Club. The first year the non-trained players had an average strike out every 4.5 times at bat, and a year after that, once every 4.6 times at bat. The visually trained players had one strike out every 5.8 times at bat the first year, and the second year had one out of every 10.6 times at bat. White (1977) discusses a vision therapy program used to enhance the visual acuity of six UCLA baseball players. All six players were given 12 hours of vision therapy and showed substantial improvement in batting average, pitching and defense. One player's batting average improved from .220 to .300 and another increased from .186 to .250. One player who did not complete the therapy had a reduction of his batting average

from .271 to .180. In a study designed to investigate the effects of visual simulation training on baseball players, Burroughs (Note 1) found that visual performance at bat can be enhanced in a short period of training time. Twenty-two college baseball players were involved in a training program to improve recognition of baseball pitch and visual extrapolation ability (perception of the pitch's location). Gain scores between the experimental group and the control group showed significant improvement in visual extrapolation ability for the group receiving simulation training. There was a lack of significant improvement of players' recognition scores which may have been because there was little room for improvement in this area (both control and experimental groups averaged 18 out of 20 correct on pretesting). In a study to design a visual simulation training film for baseball batters to improve their visual extrapolation ability, Burroughs (Note 2) found that extrapolation skills were enhanced for the group receiving the simulation training. Burroughs (Note 3), in an evaluation of a visual training device designed for batters to practice visual recognition and extrapolation skills on a regular basis, found that batting performance improved for batters on training days as opposed to non-training days. In this study, a questionnaire was also designed to evaluate the effectiveness of the training. Subjects rated the overall value of visual training 5.8 on a 1 to 7 behaviorally

defined rating scale. Responses to open-ended questions on the value of the training program were overwhelmingly positive. Burroughs comments that the importance of the task used in the training should highly simulate the actual performance task.

Visual Skills That Are Related to Ball Playing Sports

Task performance in ball playing sports has been closely correlated with dynamic visual acuity (Burg, 1966; Douglas, 1972; Ridini, 1968; Whiting & Sanderson, 1974), in particular, baseball (White, 1977; Burroughs, Note 3) and basketball (Beals et al., 1971; Dippner, 1973; Morris & Kreighbaum, 1977; Tussing, 1940). It has been called the most important visual ability in sports (Sherman, 1980; White, 1977). Other visual skills cited in research reports with respect to ball playing sports are peripheral vision (Deshaies & Pargman, 1976; Getz, 1978; Graybiel et al., 1955; Leonard, 1975; Ralston, 1977; Ridini, 1968; Sherman, 1980; Stroup, 1957; Williams & Thirer, 1975) and depth perception (Beals et al., 1971; Graybiel et al., 1955; McLaughlin, 1979; Miller, 1960; Montebello, 1960; Olsen, 1956; Runniger, 1980; Shick, 1971).

Certain researchers have stressed the need to show the relationship of specific visual skills to specific sports and sport skills within the sport (Beals et al., 1971; Getz, 1978; Graybiel et al., 1955; Morris & Kreighbaum, 1977; Olsen, 1956; Ridini, 1968; Stroup, 1957; Tussing,

1940). Though there is little research to date, the visual skills of dynamic visual acuity, peripheral vision and depth perception have been correlated specifically with the sport of volleyball (Morris & Kreighbaum, 1977; Ridini, 1968).

The purpose of this study is to determine if a two-day training program in peripheral vision enhancement training leads to improved peripheral vision on the court for female volleyball players.

Method

Subjects

Subjects were a group of 30 high school girls that ranged from age 13-17 and attended high school in the southeast United States. These subjects are from a group of approximately 150 girls who attended a summer volleyball training camp at the University of Central Florida during a 3 1/2 day session in early August. The subjects were asked to volunteer to participate in the study and then were randomly assigned to experimental and control groups of 15 each. Demographic breakdown of the experimental and control groups are presented in Table 1. This information was extracted from the Background Information Form (Appendix A) completed by each subject prior to the commencement of the training program. Average level of volleyball skill was determined by assigning scores of 1 (low), 2 (average) or 3 (high), according to the number of awards received by the subject or her home team. No awards received by the subject or her team equalled 1; awards received by the subject or her team equalled 2; and awards received by both subject and her team counted as 3.

Table 1
Demographic Breakdown of Experimental
and Control Groups

Group	<u>N</u>	Avg. Age	Avg. Grade in School	Avg. Yrs. Volley- ball Trng.	Avg. Level Volley- ball Skill ^a
Experimental	15	15.3	10.4	1.4	1.5
Control	15	15.0	10.1	1.7	1.4

^a3 = High, 2 = Medium, 1 = Low.

Apparatus

Training. The Peripheral Vision Enhancement Technique (P.V.E.T.) was designed to improve the peripheral vision of volleyball players. It employs the use of the P.V.E.T. training device (Appendix B). This device has sides which are 40 inches long, 10 inches high, and are joined at a 70° angle by a center post containing a black circle 1 inch in diameter. It has a built-in stand which is 10 inches high, containing a chin rest and joining the sides at their mid-way point, 20 inches from the 1 inch black circle. On the interior of both right and left sides are movable black circles 1/2 inch in diameter. On the exterior of both sides is the equipment for moving the 1/2 inch circles plus a measuring means the length that the black circle can travel (32 inches). The P.V.E.T. device is painted a flat neutral off-white color.

Posttest. The posttest, conducted on the volleyball court, includes a covered volleyball net, the peripheral vision test score sheet (Appendix D), the peripheral vision test placement sheet (Appendix E), and the peripheral vision test scoring instructions (Appendix F).

Evaluation questionnaire. A seven-item questionnaire (Participant's Evaluation Form) was designed to allow subjects to rate the training program (Appendix G). Two items used a 7-point rating scale to determine the effectiveness

of the program. Five items encouraged open-ended written responses.

Procedure

Prior to the start of the training session, subjects were acclimated to the P.V.E.T. equipment. Training periods were held twice a day, for two days, meeting from 8 a.m. to 9 a.m. and 1 p.m. to 2 p.m., during the girls' free time at camp. Training time per subject approximated 10 minutes per training period, a total of 40 minutes per subject.

The P.V.E.T. training device was designed specifically for this experiment. Four training devices were built and used simultaneously to better facilitate the number of subjects being trained at one time. Each of the training devices were used in a one-to-one situation between trainer and subject. The four trainers were members of the U.C.F. Women's Volleyball Team and received training in the use of the P.V.E.T. training equipment prior to the program.

Each subject was instructed to sit at the desk with the training device, put her chin in the chin rest and focus her sight directly ahead on the 1 inch black circle. As the trainer operated the device, the subject was instructed to call out "left" or "right" at the moment the 1/2 inch moving black circles appeared in her field of peripheral awareness right or left sides. The point of peripheral awareness for right and left sides was then noted by the

trainer on the Training Data Sheet (Appendix C). Each subject received 12 trials during each of the 4 training sessions. The 12 trials were interspersed with "dummy" trials using only one of the 1/2 inch black circles. These dummy trials were not recorded.

The Peripheral Vision Test for volleyball players was also designed specifically for this experiment. Each subject received a set from a setter of the U.C.F. Women's Volleyball team on the volleyball court, the covered net occluding vision below net height. On the back half of the occluded side of the volleyball court, two aides using the Peripheral Vision Test Placement Sheet (Appendix E) situated themselves on the court according to the individual test being performed. Each of the test boxes represent the back half of the volleyball court. The back half is divided into three large sections or rectangles, and each large section is divided into four smaller subsections. In each case the occluded volleyball net is below or at the bottom of the half-court represented on the Placement Sheet. Subjects were instructed to hit and place the ball in an open area, simultaneously observing the placement of the aides by using peripheral vision. The subjects were told that they would be scored on both the placement of the ball in an open area and their observation of the placement of the two aides. Immediately following each hit, the subject filled out the appropriate test on

the P.V. Test Score Sheet (Appendix D), marking an X in the corresponding section of the court where she observed the two aides, and leaving blank the area that she observed to be the open area. Each subject was allowed one trial test and then received Tests 1 through 12. Tests 13, 14, and 15 were used as backup tests. Subjects were scored using the P.V.T. Scoring Instructions (Appendix F), each subject receiving a higher score for not placing an X in the open area. Experimental and control groups received the Peripheral Vision Test during the last hour on the last day of the training camp; total test time per subject was equal to 10 minutes. Due to time constraints, the research design did not allow for pretesting of these groups.

The second measure of the study was the Participant's Evaluation Questionnaire (Appendix G). Subjects from the experimental group were asked to fill out this questionnaire following their last training period.

Experimental Design

The design, a randomized control-group posttest only design (Campbell & Stanley, 1966), is illustrated below.

	<u>Training</u>	<u>Test</u>
Experimental Group	X	X
Control Group		X

Results

Peripheral Vision Test

Means and standard deviations for the experimental and control groups on the Peripheral Vision Test are shown in Table 2. In order to test for significant differences a t test for independent samples was calculated. The test showed no significant difference between the two groups, $t(28) = 1.37, p > .05$.

Since there was no significant difference between the experimental and control groups on the posttest it appeared reasonable to conduct a further analysis to investigate the relationship between the training data and the posttest data.

A t test for independent samples was therefore calculated on the posttest scores of the top third of the training group and the bottom third of the training group as determined by their gain scores (last training session score minus first session score) using the P.V.E.T. training apparatus. Means and standard deviations for these groups are shown in Table 3. The t test showed no significant differences between the two groups, $t(8) = 1.82, p > .05$.

Table 2

Peripheral Vision Posttest Results for Experimental
and Control Groups

Group	<u>N</u>	\bar{X}	<u>S</u>	<u>t</u>
Experimental	15	-1.5	5.8	1.37
Control	15	1.1	4.5	

Note. The highest possible posttest score was +24, and the lowest possible score was -24.

Table 3

Peripheral Vision Posttest Results for Top Third and Bottom Third Experimental Group

Group	<u>N</u>	<u>\bar{X}</u>	<u>S</u>	<u>t</u>
High Third	5	1.0	6.6	1.82
Low Third	5	-7.2	3.7	

Note. The highest possible posttest score was +24, and the lowest possible score was -24.

Participant's Evaluation

Means for the Participant's Evaluation Questionnaire received from the experimental group were calculated on the items where ratings were required. Comments on open-ended questions were categorized as positive, neutral, or negative by two independent raters. There was 95% agreement between the raters.

The Participant's Evaluation Questionnaire (Appendix G) results are presented below, keyed to the questions asked on the form. A more complete list of positive, neutral, and negative comments can be found in Appendix H.

Question A1: Can vision training improve skill in playing volleyball? The mean evaluation for this question was 5.4 on the 7 point rating scale. It appeared that all of the training subjects became more educated in the use of visual skills training for sports through participating in this program. Comments included becoming "aware of using vision to your advantage."

Question A2: Will this particular training improve your volleyball skill? The mean evaluation was 4.6 on the 7 point rating scale. Comments ranged from, "Yes, because you'll know where your teammates are," to, "I really don't know, I'll have to test it out in a game."

Question B1: Length of the training program. This open-ended question was categorized as a neutral response

by the two independent raters. Several girls thought the program was "too short," and, "you didn't have time to improve very drastically."

Question B2: Scheduling of the training program. The training program was scheduled to meet during the girls' free time from 8-9 a.m. and 1-2 p.m. Responses were categorized as positive by the raters. The twice a day schedule was very acceptable but there were comments that the 8 a.m. session "found them barely awake."

Question B3: Use of the training program by the home team. This received a neutral response categorization by the raters. Girls with negative responses felt that their home teams would not take the training seriously: "People on my home team aren't dedicated enough, or don't have the incentive to want to use this training."

Question B4: Duration of training during volleyball season. For those who responded positively to Question B3, twice a week was selected for the use of the training program by the home team. Raters categorized it as a positive response. Twelve of the 15 girls said it should be used before the season begins.

Question B5: Additional comments. Eight subjects made no additional comments. Raters rated two responses as negative. One suggested more variety in the training and one complained of "feeling dizzy" and getting a headache

after training. Five responded positively, two suggesting that it was "beneficial to more sports than just volleyball."

Discussion

The study utilized two measurement tools to evaluate the effectiveness of the training program, the on-the-court Peripheral Vision Test and the Participant's Evaluation Questionnaire.

Peripheral Vision Test

It is suggested that the lack of improvement by the experimental group on the Peripheral Vision Test may be due to the fact that the training program was limited to a two day period. Since there were also no significant differences between the top third of the training group and the bottom third of the training group on their posttest scores, it is suggested that this posttest may not be a true measure of the training effects experienced. This, however, may instead be due to the small size of the top and bottom third of the training group, $N = 10$. Scheduling needs also affected the concentration of the test participants as the time period allowed for the test fell on the last hour of the last day of the camp.

Participant's Evaluation Questionnaire

The Participant's Evaluation Questionnaire results show that the trainees were in favor of visual skills

training for volleyball. The fact that they were unsure if this particular training program would help them appeared to be based on the two day time period. They were in favor of a twice a week training schedule beginning prior to the volleyball season and lasting throughout the season. Several suggested it would be necessary to educate their coaches and their home teams on the benefits of visual skills training in sports before a program could be successful.

Implications

An implication of this study was the necessity of matching the skills taught in training to the evaluation procedure. The similarity in training and testing could be strengthened through the use of moving targets in the Peripheral Vision Enhancement Device, more closely simulating the horizontal and vertical movement of action on the volleyball court. Through the development of the study, the difficulty in developing an on-the-court criterion measure for peripheral vision was experienced. However, the value of using such a measure became more fully realized. This measure could be adjusted according to the average age and level of ability of the subjects involved in subsequent peripheral vision enhancement procedures.

It is hoped that this training program can be utilized for improving volleyball skill for girls and in developing other visual training programs to improve sports performance.

Appendices

Appendix A
Background Information

Background Information

Your cooperation is asked in filling out this form as completely and honestly as possible. All information will be treated as completely confidential.

1. Name: _____
2. Age: _____
3. City and State you are from: _____
4. Year in School: (please check)
 - a. 9th grade _____
 - b. 10th grade _____
 - c. 11th grade _____
 - d. 12th grade _____
 - e. Other _____
5. Years playing on Volleyball Team: _____
6. Awards, scholarships, etc., in volleyball you or your team have received:

You

Team

BOLD
OLD CORNET BEE



Appendix B

Peripheral Vision Enhancement Training Device

Peripheral Vision Enhancement Training Device

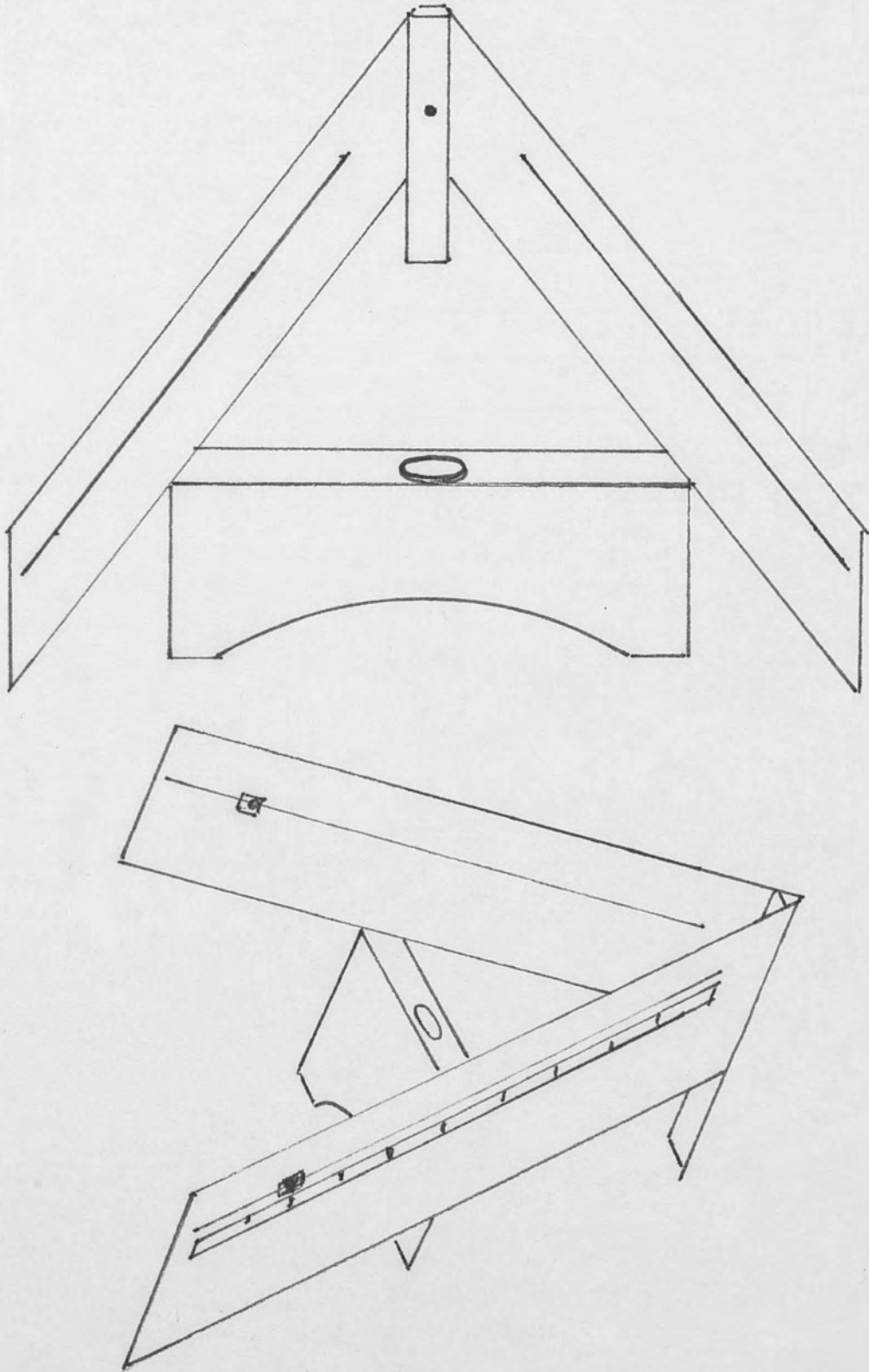

NEW YORK LIBRARY
BOARD
OF GOVERNMENT LIBRARIANS



Appendix C

Training Data Sheet

Training Data Sheet

Name: _____

Training Session 1Trials
(Results in Inches)

L	R	L	R	L	R	L	R	L	R	L	R
1		2		3		4		5		6	
7		8		9		10		11		12	

Training Session 2

Trials

L	R	L	R	L	R	L	R	L	R	L	R
1		2		3		4		5		6	
7		8		9		10		11		12	

Training Session 3

Trials

L	R	L	R	L	R	L	R	L	R	L	R
1		2		3		4		5		6	
7		8		9		10		11		12	

Training Session 4

Trials

L	R	L	R	L	R	L	R	L	R	L	R
1		2		3		4		5		6	
7		8		9		10		11		12	

100% COLONY LIBER
POINT
AND QUALITY LIBER



Appendix D

Peripheral Vision Test Score Sheet

Peripheral Vision Test Score Sheet

Name: _____

Trial
Test

Test
1

Test
6

Test
2

Test
7

Test
3

Test
8

Test
4

Test
9

Test
5

Test
10

Test
11

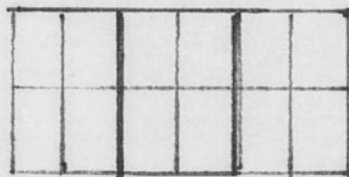

Test
12

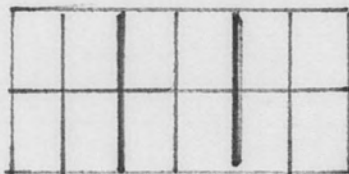

Test
13



Test
14



Test
15

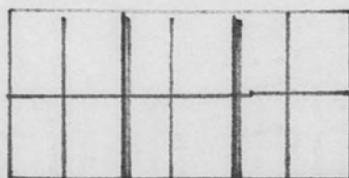

Appendix E

Peripheral Vision Test Placement Sheet

Peripheral Vision Test Placement Sheet

Aide: _____

Trial
Test

	X				
			X		

Test
1

X					
				X	

Test
6

X				X	X

Test
2

		X			
					X

Test
7

				X	
			X		

Test
3

	X		X		

Test
8

	X				
					X

Test
4

					X
X					

Test
9

X					
		X			

Test
5

	X	X			

Test
10

X				X	

Test
11

			X		
X					

Test
12

				X	
	X				

Test
13

		X			
				X	

Test
14

X					
					X

Test
15

	X				
			X		

Appendix F

Peripheral Vision Test Scoring Instructions

Peripheral Vision Test Scoring Instructions

- +2 = Two correct X's in subsections of backcourt, no X in open area
- +1 = One correct X in subsections of backcourt, no X in open area
- 0 = No correct X's in subsections of backcourt, no X in open area
- 1 = One correct X in subsections of backcourt, X in open area
- 2 = No correct X's in subsections of backcourt, X in open area

Appendix G

Participant's Evaluation Form

Participant's Evaluation Form

Your honest and critical evaluation of the vision training program you have just completed will help in developing similar programs designed to improve volleyball performance. Please complete each section carefully.

A. Answer each question using the scale marked from 1 to 7 by choosing the number closest to how you feel. Put the number you choose on the line next to the question.

1. Do you think that vision training can improve skill in playing volleyball? Answer _____

No, I
defi-
nitely
don't
think
so

No, I
don't
think
so

Yes, I
think
so

Yes, I
defi-
nitely
think
so

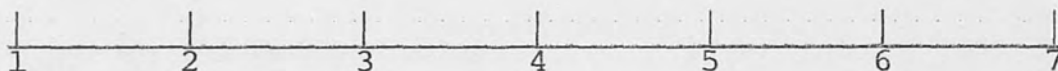

Comments:

2. Do you think that this particular vision training program will improve your skill in playing volleyball? Answer _____

No, I
defi-
nitely
don't
think
so

No, I
don't
think
so

Yes, I
think
so

Yes, I
defi-
nitely
think
so

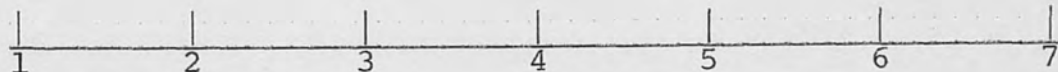

Comments:

B. Please answer each question as completely as possible.

1. Describe your reaction to the length of the training program. Was it too long? Too short? How long do you think it should be?

2. Describe your reaction to the scheduling of the training program. Was the training held too often or not often enough each day? Would you recommend a different schedule? If so, what type?

3. Would you recommend that this training program be used by your home volleyball team? (check one)

Very definitely _____
 Definitely _____
 Probably _____
 Maybe _____
 No, not at all _____

Why do you feel this way:

4. If you recommend this training program be used by your home volleyball team, how often during the season do you think it should be used? (check one)

Daily _____
 Twice a week _____
 Once a week _____
 Once every two weeks _____
 Once a month _____

Do you think it should be used before the season begins?

5. Please use the following space for any additional comments you may have.



Appendix H

Samples of Positive, Neutral, and Negative Comments from
the Participant's Evaluation Questionnaire

Samples of Positive, Neutral, and Negative Comments from
the Participant's Evaluation Questionnaire

Question A1: Can vision training improve skill in playing volleyball?

Positive: Because it helps you to realize that you can see a player on both sides of you.

You have to be aware all the time what everyone else is doing. You have to be able to really watch a part of your opponent and see another part or player.

I think it's helped me to be aware of using vision to your advantage.

Neutral: I don't know too much about this but I'm interested.

Negative: None.

Question A2: Will this particular training improve your volleyball skill?

Positive: I think it will help because you'll know where your teammates are.

I think it helps you to be more aware of your surroundings.

Neutral: I really don't know. I'll have to test it out in a game.

I'm not really sure if it would help me in volleyball, or volleyball players in general but it could be useful in other sports. I think it could help soccer players a great deal.

Negative: I don't really know, it doesn't seem like it has anything to do with volleyball.

Question B1: Length of the training program

Positive: I think it was just long enough, because if you had it too long they would get bored with it, and if it was too short they wouldn't learn enough.

I think it was O.K., not too long and it still let us in on our free time.

Neutral: At first it seemed too long but to help yourself it probably should be done a lot.

It was just about right. It gets a little boring though.

Negative: I thought it was too short and you don't have time to improve very drastically. It probably should have been over a longer time.

The program was too short but a longer training session would help your vision even more.

Question B2: Scheduling of the training program

Positive: The schedule of training seemed perfect to me, the twice a day routine was often enough yet it didn't become tedious.

The schedule was fine. It gave you something to look forward to, something different.

Neutral: The scheduling was good to fit into other schedules.

I think you should schedule two sessions but the first session is too early because some of us were barely awake.

Negative: I think the program was held too often but time might interfere.

Too often. Should have been only once a day.

Question B3: Use of the training program by the home team

Positive: I feel that this training teaches us to be aware of what is going on around us and we learn to know what to expect from our opponents and teammates.

Neutral: I don't know if this experiment really helps or not. The experiment was a great idea and I do have thoughts both ways if it does any good.

Negative: I don't think our school takes the volleyball program that serious.

I'm not sure the players would feel it was important, and we would need someone who understood this type training.

Question B4: Duration of training during volleyball season

Positive: Should be used twice a week.

Training should be used before the season begins in order to get started before games, where it would pay off.

It should be used twice a week and before the season begins to get used to doing it.

Neutral: Should be used once a week and before the season begins if it shows an effect.

Negative: None.

Question B5: Additional comments

Positive: This is a good idea and can be extremely beneficial to more sports than just volleyball.

Neutral: I thought this was okay. I can't say much because I don't know the results yet.

Negative: It gives you a headache doing it so many times one after the other.

Reference Notes

Reference Notes

1. Burroughs, W. A. Improvement of baseball hitters' visual skills through slow motion visual simulation training. Paper presented at the Southeastern Psychological Association convention, March 1979.
2. Burroughs, W. A. Visual simulation training of baseball hitters. Paper presented at the Southeastern Psychological Association convention, March 1980.
3. Burroughs, W. A. Evaluation of a visual training technique for collegiate baseball batters. Paper presented at the Southeastern Psychological Association convention, March 1981.

References

References

- Bauscher, W. Vision and the athlete. Optometric Weekly, 1968, 59, 21-25.
- Beals, R. P., Mayyosi, A. M., Templeton, A. E., & Johnston, W. L. The relationship between basketball shooting performance and certain visual attributes. American Journal of Optometry, 1971, 48, 585-590.
- Bennett, I. Optometry's role in sports. Optometric Management, 1979, 15(6), 35-49.
- Burg, A. Visual acuity as measured by dynamic and static tests. Journal of Applied Psychology, 1966, 50, 460-466.
- Campbell, D., & Stanley, J. Experimental and quasi-experimental designs for research. Chicago: Rand McNally, 1966.
- Deshaies, P., & Pargman, D. Selected visual abilities of college football players. Perceptual and Motor Skills, 1976, 43, 904.
- Dippner, R. The relationship between basketball ability and visual acuity in the unicorn. American Journal of Optometry, 1973, 50, 656-661.
- Douglas, D. Effect of basketball hitting of limiting vision of the path of the ball (Masters thesis, University of Oregon, 1972). Masters Abstracts, 1972, 11, 105. (University Microfilms No. 13-04,030)
- Garner, A. I. Visual aid prescribing for the athlete. California Optometrist, 1977, 3(6), 18-19.
- Getz, D. J. Vision and sports. Journal of the American Optometric Association, 1978, 4, 385-388.
- Graybiel, A., Jokl, E., & Trapp, C. Russian studies of vision in relation to physical activity and sports. Research Quarterly, 1955, 16, 212-223.

- Harrison, W. Vision dynamics and baseball. Success Motivation Institute, Inc., 1977. (Cassette)
- Leonard, G. The ultimate athlete. New York: Viking Press, 1975.
- Martin, W. F. What the coach should know about the vision of athletes. Optometric Weekly, 1968, 61, 558-560.
- McLaughlin, R. Bright ideas. Physical Educator, 1979, 36(2), 103-104.
- Miller, D. The relationship between some visual-perceptual factors and the degree of success realized by sports performers (Doctoral dissertation, University of Southern California, 1960). Dissertation Abstracts, 1960, 21, 1455. (University Microfilms No. 60-04,484)
- Montebello, R. The role of stereoscopic vision in some aspects of basketball playing ability. Unpublished masters thesis, Ohio State University, 1960.
- Morris, G., & Kreighbaum, E. Dynamic visual acuity of varsity women volleyball and basketball players. Research Quarterly, 1977, 5, 481.
- Olsen, E. A. Relationship between psychological capacities and success in college athletics. Research Quarterly, 1956, 27, 79-89.
- Parker, R. L. Optometrist's role in the 1980 Olympics. Journal of the American Optometric Association, 1980, 51, 655-656.
- Pitts, D. The role of vision in sports and recreational activities. Southern Journal of Optometry, 1974, 16(11), 11-15.
- Ralston, D. Six weeks to a better level of tennis. New York: Simon & Schuster, 1977.
- Ridini, L. M. Relationship between psychological functions tests and selected sport skills of boys in junior high school. Research Quarterly, 1968, 39, 674-683.
- Runniger, J. Eyes on the ball: An oversimplification. Journal of the American Optometric Association, 1980, 7, 667.

- Sherman, A. Overview of research information regarding vision and sports. Journal of the American Optometric Association, 1980, 7, 661.
- Shick, J. Relationship between depth perception and hand-eye dominance and free-throw shooting in college women. Perceptual and Motor Skills, 1971, 33, 539-542.
- Stroup, F. Relationship between measurements of field of motion perception and basketball ability in college men. Research Quarterly, 1957, 28, 72-76.
- Trachtman, J. N. The relationship between ocular motilities and batting averages in Little Leaguers. American Journal of Optometry, 1973, 50, 914-919.
- Tussing, L. The effect of football and basketball on vision. Research Quarterly, 1940, 11, 16-18.
- White, V. W. Visual acuity vs. visual skill in athletic performance. California Optometrist, 1977, 3(6), 22-23.
- Whiting, H., & Sanderson, F. Dynamic visual acuity and performance in a catching task. Journal of Motor Behavior, 1974, 6, 87-94.
- Williams, J., & Thirer, J. Vertical and horizontal peripheral vision in male and female athletes and non-athletes. Research Quarterly, 1975, 46, 200-205.