Electronic Theses and Dissertations, 2004-2019

2015

"Build Your Own Adventure" ACT Prep Manual: Beating the Odds of High-Stakes Standardized Assessments

Natalie Holter
University of Central Florida



Part of the [Education Commons](#)

Find similar works at: <https://stars.library.ucf.edu/etd>

University of Central Florida Libraries <http://library.ucf.edu>

This Doctoral Dissertation (Open Access) is brought to you for free and open access by STARS. It has been accepted for inclusion in Electronic Theses and Dissertations, 2004-2019 by an authorized administrator of STARS. For more information, please contact STARS@ucf.edu.

STARS Citation

Holter, Natalie, "'Build Your Own Adventure" ACT Prep Manual: Beating the Odds of High-Stakes Standardized Assessments" (2015). *Electronic Theses and Dissertations, 2004-2019*. 676.

<https://stars.library.ucf.edu/etd/676>



“BUILD YOUR OWN ADVENTURE” ACT PREP MANUAL:
BEATING THE ODDS OF
HIGH-STAKES STANDARDIZED ASSESSMENTS

by

NATALIE HOLTER
B.A. Yale University, 1997
M.L.S. Rollins College, 2010

A dissertation in practice submitted in partial fulfillment of the requirements
for the degree of Doctor of Education
in the College of Education and Human Performance
at the University of Central Florida
Orlando, Florida

Summer Term
2015

Major Professor: David Boote

© 2015 Natalie Holter

ABSTRACT

Today's focus on high-stakes standardized tests has had a massive impact on education throughout America, and standardized test preparation is one of the ugly, open secrets of education. Ever since 2001 when President Bush signed into law No Child Left Behind (NCLB), a bipartisan reauthorization of Johnson's landmark Elementary and Secondary Education Act of 1965, students have been bombarded with standardized tests from the earliest grades. Politicians believe these measures are the only way to remedy the perceived weaknesses in the education system because "stringent accountability mandates... [provide] vital levers of change, inclusiveness, and transparency of results" (Education Week, 2011, para. 15). Yet as time progresses, the quantity and importance of the exams increase to such proportions that, by the time students are in high school, their performance dictates whether they will graduate or attend college. While proponents of such exams say that they only test the skills that students ought to be learning anyway, the reality tends to be that teachers start to focus only on the specific questions the test will cover, and thereby lose the ability to provide full, comprehensive education. "Teaching to the test" is the much-maligned experience of most high schools. In order to combat the pressure students feel to perform and teachers feel to shortchange the learning experience, a "Build Your Own Adventure" manual designed around research-based principles demonstrated to improve student learning gains will allow students to focus on the key areas needed to improve test performance, demystify the test itself, and thus help students obtain score improvement. In so doing, students will not only perform better on standardized assessments, but ultimately be able to attend more elite colleges.

TABLE OF CONTENTS

LIST OF FIGURES	vi
LIST OF TABLES	vii
CHAPTER ONE: PROBLEM OF PRACTICE AND ORGANIZATIONAL ANALYSIS	1
Problem of Practice	1
Organizational Context	2
Local History and Conceptualization of the Problem	5
National/International History and Conceptualization of the Problem	15
CHAPTER TWO: DESIGN CONSIDERATIONS AND JUSTIFICATION	28
Digital Manual.....	36
CHAPTER THREE: EVALUATION AND DISCUSSION	44
Evaluation Plan	44
Instrumentation.....	47
Instrument 1: Course Evaluation Survey by Student.....	49
Instrument 2: Teacher Interview Protocol.....	51
Instrument 3: Student Interview Protocol.....	52
Limitations	53
Discussion and Implications.....	53
APPENDIX A: IRB APPROVAL LETTER	56
APPENDIX B: MANUAL EXEMPLAR	58

APPENDIX C: IMPLEMENTATION OF DESIGN ELEMENTS.....	97
APPENDIX D: CURRICULUM FLOW OF FULL MANUAL.....	104
REFERENCES	107

LIST OF FIGURES

Figure 1. National merit analysis, total test takers versus recognized top performers	6
Figure 2. Influence of coaching on college admissions.....	24
Figure 3. Impact of anxiety level on mathematical scores.....	35
Figure 4. Model of memory as augmented by multimedia learning	37
Figure 5. Learning environments as driven by curriculum format.	38

LIST OF TABLES

Table 1. Demographic Data of TFA as compared to the city of Orlando.....	3
Table 2. Millman's Outline of Test-Wiseness Principles.....	33
Table 3. Mayer's Principles for Designing Effective Instructional Multimedia Materials	41
Table 4. Evaluation Questions / Data Sources and Methods	45
Table 5. Logic Model.....	46

CHAPTER ONE:

PROBLEM OF PRACTICE AND ORGANIZATIONAL ANALYSIS

Problem of Practice

At The First Academy (TFA), a Christian private school in Orlando, Florida, the end-game for the most high school students does not vary, regardless of race, socio-economic status, or gender: their goal is to be admitted to a quality college. Obviously there are various components necessary to successfully complete the application process, and as such the school has provided extensive resources to aid students in the creation of resumes, college essays, and other items. Yet despite the importance the school has placed on the process, one particular piece remains elusive: strong student performance on high-stakes assessments. Standardized exams like the PSAT, SAT, and ACT have, rightly or wrongly, played a significant role in whether students are admitted to college, especially at the most elite universities in the country. Yet TFA, like nearly every private school, looks at the admission rates of students to these elite schools as more than just a point of academic interest. In a very real sense, it is as important to the school from the business standpoint as the price of tuition or number of enrolled students, because to the parents who trust TFA with their children's academic future and the other schools against whom it competes for the top students in the area, these rates become very real indicators of success.

Clearly these exams are important to more than just the students themselves. Yet they have long been plagued by accusations of bias and lack of transparency. Likewise, the very notion that a "snapshot" of student performance at one moment in time will indicate student success in college has also come under fire. TFA thus has had no choice but to make improved standardized test performance a priority, particularly for juniors and seniors, and has in turn

encouraged students to seek outside coaching if necessary to raise their scores. Yet these programs do not come often without significant cost and only haphazard success. If President Obama's dream of universally available college is to be realized (Mason, 2015) and TFA is to further develop its reputation as a serious academic institution, an alternative must be developed that will provide all students—not just the wealthy—with the ability to understand the nuances of these exams and improve their performance.

Organizational Context

The First Academy (TFA) in Orlando, Florida, has been providing a quality Christian education to its students for over 25 years. Approximately 1,200 students attend the school, and that number has only increased every year in the last decade, despite the concurrent economic recession that has threatened the financial environment for most private schools nationwide. The school operates six distinct divisions: Preschool (ages 8 weeks to 3 year), Lower School (K4 to 6th grade), Middle School (7th and 8th grade), Upper School (9th to 12th grade), Classical School (hybrid homeschool/class environment for K to 12th grade), and First Hope (a program for special needs children for K to 12th grade). Specifically, the high school division itself has increased in enrollment by nearly 100 percent over the same time period, and now houses approximately 420 students each year. Racially, the school deviates significantly from the surrounding Orlando area, with a higher proportion of White (non-Hispanic) students, and fewer Black and Hispanic students, as the table below indicates.

Table 1. Demographic Data of TFA as compared to the city of Orlando

Race	Orlando	TFA
White (non-Hispanic)	41.30%	70.27%
Black or African American	28.10%	7.58%
Hispanic or Latino	25.40%	7.86%
Asian	3.80%	3.51%
Two or More Races	3.40%	4.45%
American Indian and Alaska Native	0.40%	0.19%
Native Hawaiian and Other Pacific Islander	0.10%	0.47%
Unknown	*	5.68%

Sources: US Census Bureau, 2014; T. DeBoom, personal correspondence, September 26, 2014¹

Although the admissions department does not capture demographic data on its families regarding income, in general they are affluent, paying \$16,437 on average for annual tuition (The First Academy, 2014), plus activity fees. Yet, not every student fits this mold. Tim DeBoom, Business Administrator for the school, indicates that approximately 25 percent of TFA’s students receive tuition assistance, and that the average award is approximately 50 percent of the annual tuition cost (personal communication, September 26, 2014). All these families do share one important trait, though: a desire for an academic environment that is simultaneously religious. In fact, the school’s mission pervades every aspect of its operation: "The First Academy is a Christ-centered, college-preparatory school whose mission is to prepare children for life as Christian leaders who choose character before career, wisdom beyond scholarship, service before self, and participation as a way of life" (The First Academy, 2013, para. 1). For many years, the moral component of this mission proved more seminal than the academic. Classroom activities took

¹ The Orlando data was drawn from 2010 census information as reported by the Census Bureau, which did not report any “unknown” races; TFA data was drawn from school records captured on admissions applications.

second place to athletic outings and class-building activities. Teachers would not push challenging learning activities on their students for fear of hurting grade point averages. Ultimately, TFA developed a reputation as a country club school that produced "nice kids" who performed reasonably well in the classroom, but were not likely to win major academic accolades from the universities they would attend.

That changed about 10 years ago when Dr. Steven Whitaker took over as Headmaster. He recognized that TFA faced coming difficulties due to its rigidity in subjugating academics to the ethical goals of the school. While the moral development of students must be paramount, there need not be a competition between that and scholarly achievement as these goals are not mutually exclusive. Effective organizations need to provide a central focus on key missional elements, but simultaneously provide autonomy to individuals to best serve individual needs as they arise, because those cannot always be totally anticipated by directors (Canales, 2014). As Owens & Valesky (2011) indicate, "In a world characterized by rapid change, [inflexible] organizations tend to be viewed as unhealthy; they emphasize maintenance of the organization at the expense of the need for constant adaptability to keep pace with the change in the demands and expectations of its external environment" (p. 182). Thus under the leadership of Dr. Whitaker and the collection of like-minded administrators he gathered together to aid him, the school fundamentally adjusted its academic expectations. Class time became as sacrosanct as weekly chapel. Extracurricular activities and athletic events could no longer take place in lieu of the regular daytime school schedule. Academic rigor grew with the implementation of Advanced Placement courses in the high school. These and many other changes fundamentally altered the atmosphere of the school, and TFA developed the reputation as a strong college-preparatory school across the curriculum but did not lose the Christian morality so fundamental to its

mission. The effects of these changes manifested almost immediately. The school has always boasted a 100 percent college acceptance rate for its graduates, but the quality of the colleges the students attended post-graduation improved. TFA can now report admissions to some of the most elite colleges in the country, including Yale, Princeton, the University of Pennsylvania, and the US Naval Academy. The amount of scholarship money awarded to its students has grown exponentially as well, reaching \$17.1 million last year, or over \$140,000 per graduate. The fledgling AP programs instituted just a few years ago likewise have grown from the handful of students who sat for the first test to more than 400 exams administered last year, achieving pass rates that exceeded the national average.

Local History and Conceptualization of the Problem

Despite the laudatory achievements TFA has achieved to date, one arena that could confirm the academic turnaround of the last decade remains tantalizing aloof: The performance of the typical student on high-stakes standardized assessments like the PSAT, SAT, and ACT. The number of PSAT National Merit Scholars the school produces each year exemplifies the problem. This accolade is earned by very narrow percent of elite students each year, based on their performance on the PSAT/NMSQT, as the figure below indicates. Of all PSAT test-takers each year, only approximately 0.5 percent will actually achieve National Merit status (College Compass, 2012, para. 1).

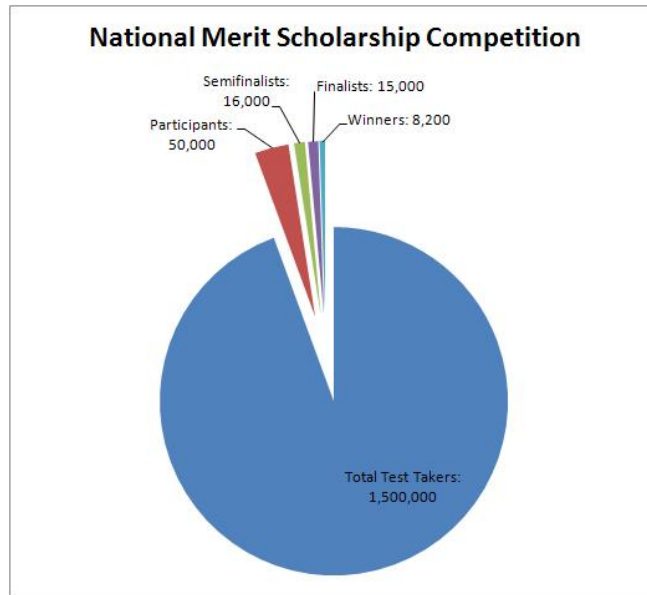

Figure 1. National merit analysis, total test takers versus recognized top performers

Source: College Compass, 2012, para. 1

These scholars exemplify the goals of the National Merit Scholarship Corporation to "promote a wider and deeper respect for learning in general and for exceptionally talented individuals in particular, [and] to shine a spotlight on brilliant students and encourage the pursuit of academic excellence at all levels of education" (National Merit Scholarship Corporation, 2013, para. 3). Past recipients of this award have included such notable individuals as Microsoft's Bill Gates, Chief Justice John Roberts, Amazon.com founder Jeff Bezos, film director and producer M. Night Shyamalan, and Federal Reserve Chairman Ben Bernanke, among others (National Merit Scholarship Corporation, 2013). TFA has sought to increase the number of students who qualify for this award not only for the students' benefit, but also to demonstrate as an objective measure just how far the school has come in terms of academics. The importance placed on statistics like these emphasize the current state of education and its dominant focus on standards-based reform and data-driven decision making.

This focus on standards-based reform came to the forefront in the late 20th century as the US started to lag in international measures of academic performance. Educational reformers pointed to reports such as *A Nation at Risk* and predicted grave decline in the future if strict changes were not implemented immediately. Ultimately, these concerns led to the institution of No Child Left Behind (NCLB), a bipartisan reauthorization of Johnson's landmark Elementary and Secondary Education Act of 1965. NCLB mandates that public schools demonstrate certain measures of student success in the form of standardized assessments. Yet despite this bureaucratic focus on public schools, private schools, at least those like TFA that wish to compete academically as sincere college-preparatory institutions that attract the best students, become just as heavily affected by such legislation. One major consideration is the pocketbook: At rigorous institutions like TFA, parents pay a lot of money and therefore have high expectations for student performance. If those parents become dissatisfied with student learning, they withdraw their children, and the school flounders financially. Prior to the NCLB-era focus on standardized assessment, they might have accepted a high college acceptance rate and a few Ivy League matriculations as evidence of success. Now, however, that is not enough; they want high standardized test scores as well. Even the National Association of Independent Schools, the preeminent accreditation service and political advocate for non-public schools in the country, has identified this shift in consciousness on the issue: "The pressure for measurable accountability is clearly increasing.... Accreditation at both the university and school levels has come under attack on the grounds of 'cronyism' (a small and collegial group is called upon to conduct accreditation visits) and on the charge that the process largely measures inputs (library volumes, faculty credentials, computers per student) rather than outputs (evidence of student learning)" (Bassett, 2004). Therefore, schools such as TFA have no choice but to embark voluntarily on the

standardized assessment bandwagon that public schools have been pulled into involuntarily, and the number of National Merit Scholars that the school produces has become one of the more visible indicators of academic rigor in the last decade.

While there have been some students at TFA in the recent past to achieve this milestone—two in 2011, two in 2012, three in 2013, one in 2014, and one in 2015, for example, represent the most recent—that simply does not provide enough evidence to prove that the school has made the dramatic turnaround academically that our stakeholders require because this particular indicator has symbolically taken on a more significant meaning. Bolman & Deal (2008) argue that one of the basic assumptions underpinning the symbolic frame is the concept that "events... are often more important for what is expressed than for what is produced. Their emblematic form weaves a tapestry of secular myths, heroes and heroines, rituals, ceremonies, and stories to help people find purpose and passion" (p. 253). This has certainly become the case for the PSAT. The actual benefits of achieving National Merit status—a possibility of earning up to \$2000 in scholarship money, hardly worth mentioning in comparison to the expense of most elite colleges in the country—pale in comparison to the importance high schools and colleges place on the achievement as illustrative of something much deeper. Private schools and, in turn, their families and academic competitors, use this as a measure to demonstrate the caliber of academic achievement engendered at any individual school because it derives from an objective standard of accomplishment beyond easy means of manipulation or misrepresentation. Such external evaluation bears heavier weight than any internal measure of success; "Evaluation assures spectators that an organization is responsible, serious, and well managed" (Bolman & Deal, 2008, p. 304). Likewise, the ritualistic significance the celebration of said accomplishments takes on reinforces to stakeholders both internal and external the importance

this test has for the school. It reveals otherwise unspoken perceived value inherent to the accomplishments of an organization and thus can become a mechanism by which the organization is either lauded or derided (Dandridge, Mitroff, & Joyce, 1980).

The PSAT is a fairly accurate predictor of performance on the SAT and even the ACT, though to a lesser degree. Thus the school's intention to improve PSAT scores, though perhaps initiated for somewhat self-serving reasons, should have the additional benefit of improving those tests as well, ultimately leading to more student admission to more selective colleges. Yet improving test scores can be viewed as both an individual and an organizational enterprise, which of course complicates any attempts to raise them. On the individual level, all domains (cognitive, motivational, behavioral, and cultural) oftentimes conspire to hurt student performance. From a cognitive standpoint, student learning in high school bears little resemblance to the type of content frequently tested. The types of skills are different, the manner of expression varies, and the limiting timing for each section makes it difficult for students to just "adapt" unless they have at least some previous experience with the structure and format of the test. Likewise, from a metacognitive standpoint, the students who go in blind to take tests like the SAT and ACT have to learn the various test-taking strategies and approaches for each, as well as their own unique strengths and weaknesses in regards to the types of questions typically presented. The different scoring rules, varying sections, etc., often create cognitive overload, and students struggle to recover quickly given the high-pressure nature of the test. "The nature of the cognitive process depends on the subject matter to which it is applied" (Anderson & Krathwohl, 2001, p. 88), meaning that even though students have taken standardized tests of various kinds for years, that experience will not necessarily transfer to new situations because of how context driven such skills tend to be. Therefore even students who are quite successful in a traditional

academic setting may not be able to easily transfer that knowledge and cognitive ability to a different standardized test.

Motivation seems like it would be the one area working in a student's favor, but this proves not the case. This erroneous common opinion has been frequently touted in research: “Because SAT scores are widely used in college admissions decisions, potential examinees (often urged on by their parents) are highly motivated to perform as well as they possibly can” (Becker, 1990, p. 373). The assumption underpinning statements such as these suggests that students belonging to a group of high-performing learners tend to be highly motivated to perform well on high-stakes assessments without any external interference; when students have achieved a high degree of academic success as underclassmen, the innate drive and high college aspirations tend to naturally follow. Yet despite this interest, high motivation to perform well on standardized tests does not necessarily lead to actual improved performance because even though the most serious students certainly do want to go to better colleges, that fact does not necessarily translate into the motivation needed to actually engage in the behaviors that will lead to success on the test (Ryan, Ryan, Arbuthnot, & Samuels, 2007). In addition, students often lack positive feelings of self-efficacy, or “one's beliefs about accomplishing a task and can influence choice of activities, effort, persistence, and achievement” as originally described by Bandura (Schunk, 1995, p. 112), in the content areas being measured, and—wrongly—believe that they will not be able to improve performance, even if they tried. This likewise connects to the broader cultural attitude that, frankly, companies like College Board have tried to promulgate: that you cannot improve performance on tests like the SAT because you cannot change your innate reasoning and logic skills (College Board, 2014b). Either you're good at the test or not, so don't bother looking more deeply or trying any harder.

While politicians and college admissions experts justify their focus on the use of high-stakes assessments based on ideal students who will always be motivated to perform at their best, those ideal students are more commonly outnumbered by real individuals who struggle with the perceived implications of the test in ways probably not intended originally by the test writers. “Real test takers are students who may not be sure about what they know, whether they want to do well, or how they feel. . . . There is a psychological dimension to the way real test takers respond to tests and items” (Ryan, Ryan, Arbuthnot, & Samuels, 2007, p. 11). As individuals begin to work on a given task, the feedback they receive on their success informs their continued learning and performance. If that feedback loop reinforces feelings of alienation or lack of ability, motivation drops; if the loop reinforces feelings of accomplishment or success, motivation improves. The challenge comes in providing authentic feedback to students that points out negative performance traits in such a way that students are encouraged to continue trying without giving into frustration or a sense of futility.

Lastly from a motivation standpoint, the behavioral element that hinders the individual is the same that afflicts students in any academic environment: it is not as fun to prepare for a four-hour test as it is to do almost anything else. Students face issues of endurance, distraction, the competing time obligations so common for today's teens, and any other multitude of things striving to divert the attention. Likewise, since students already do not feel empowered in their ability to make substantive improvement on the test as discussed above, other behavioral issues and disruptions can manifest as a means to mask their perceived lack of intelligence (Steele, 2011).

The individual concerns are only part of the problem. Many organizational issues can affect the difficulty of preparing students more adequately for standardized tests as well. The

financial concerns related to the potential loss of tuition dollars also introduce a political element to the situation. Bolman & Deal (2008) identify the allocation of scarce resources as a significant factor in organizational behavior, particularly because diverse groups begin to compete for those resources. “Consensus around how to achieve curricular improvements, or whether improvement is even necessary, remains an ongoing discussion” (Lyon, Nadershahi, Nattestad, Kachalia, & Hammer, 2014, p. 43). The tuition dollars at risk should TFA fail to demonstrate academic success across all its facets—especially in terms of performance on the high-risk standardized assessments that have become so commonplace in the educational arena—therefore heightens the challenge the school currently faces. The multitude of other schools vying for those same families, not to mention the public schools which families could attend for free, means that in a very real sense the school could face economic disaster should a perceived lack of academic rigor result in even a minor exodus of enrollment. This issue becomes especially pertinent considering the economic downturn the country experienced in the last decade, as "the concept of scarce resources suggests that politics will be more salient and intense in difficult times" (Bolman & Deal, 2008, p. 196). With fewer families able to bear the financial burden of private school tuition, every family lost becomes even more important and potentially irreplaceable.

The problem can also be construed as a human resources problem at the organizational level. Teachers tend to focus on their content in class—whether it be a foreign language, science, or physical education—and do not want to be involved with anything they might be able to articulate as "teaching to the test" (Bonds, 2008). As a result, on standardized tests that focus more on skills and critical analysis, rather than pure academic content, students can flounder because they have not been trained in class in that manner. While standards-based reform can positively impact educational environment by allowing teachers to streamline content covered,

critics complain that the actual impact of such high-stakes exam in the classroom is the unacceptable narrowing of curricular content to only the few skills actually assessed on the test. Teachers also complain that they lack any sort of autonomy to teach what is uniquely appropriate for their students because of the focus they have on the lowest quartile of student performers, “moving the bubble kids” out of the danger zone in keeping with NCLB (Desimone, 2013).

To return to the situational context in this situation, despite the obvious challenges the students and school face in regards to standardized tests, frankly TFA more or less ignored the problem of standardized test scores and the associated impact they had on the organization as a whole until about ten years ago. At that point, The First Academy was still in its nascent stages as an organization, and was focused more or less on establishing the practices necessary for the school to survive and ultimately thrive in the tough economic environment of private schools. However, once Dr. Whitaker took the helm, he realized that performance on standardized tests is a key element of perceived success in the community. If the students who graduate from TFA's halls are not able to achieve the academic success they want in college because they simply could not be admitted, that would lead to fewer enrollments, fewer tuition dollars, and thereby less stability.

As such, intentional organizational changes have been implemented. Specifically in the mathematic and English departments at the high school, numerous personnel changes have occurred in the attempt to find the right mix of content and skill needed to reach the students. Likewise, optional electives are offered during the class day specifically focused on one element of the SAT, like grammar or reading. Those electives allow students to acquire credits for graduation while simultaneously addressing the areas of weakness a student might encounter on

the test. However, these organizational changes only tangentially address the individual issues a student might face.

Based on the research about standardized tests that has been conducted and the growing importance that such high-stakes assessments have seen in recent years, the administration at TFA opted to take a direct approach in attempting to increase the number of National Merit Scholars it produces each year. It endeavored to develop a classroom course specifically directed at the highest performing high school students currently enrolled. As such, the school intends to provide specific test guidance to its strongest students so that they may excel on the assessment. The development of this sort of program reflects a structural approach to the question, hardly surprising given that educational institutions tend to be highly focused on this organizational frame. Bolman & Deal (2008) identify two major assumptions that underlay this approach: organizations can achieve heightened performance objectives through the appropriate delegation of labor, and that any inadequacies discovered can be remedied through thoughtful restructuring. The highly hierarchical organization of TFA easily lends itself, then, to a structural solution to the problem. By "promulgat[ing] clear plans and schedules for participants to follow" and "develop[ing] clear written rules and procedures to set standards and guide actions" (Owens & Valesky, 2011, p. 15), TFA hopes to literally create a recipe for success that outfits the most outstanding of its underclassmen with the specific knowledge they need to succeed, the curricular materials to teach and reinforce that knowledge, and the motivation to make them want to achieve the goal that would benefit the school, arguably, more than themselves.

This last point returns the conversation to that of the human resources frame according to Bolman & Deal (2008), who would point to motivation and individual goals as indicative of that arena. "People and organizations need each other" (p. 122), and that certainly proves to be the

case in this situation. Students need TFA to be strong academically and otherwise in order to achieve any aspirations they may hold of elite college attendance; TFA needs strong students who can perform to the rigor demanded of the PSAT in order to achieve the acclamation of its stakeholders. The question then becomes how best to harness student interest, motivation, and learning skills effectively to create the standardized test superstars the school desires.

National/International History and Conceptualization of the Problem

The institutional desire to craft a successful test prep program, while key to TFA's success as a private school in a competitive environment, is obviously not unique. While research on standardized tests and student performance has been conducted since almost immediately after the inception of the first multiple choice exam, it became more common in the 1980s in the wake of *A Nation At Risk* and the ensuing era of education reform. In this day and age of data-driven decision making, students have been bombarded with standardized tests from the earliest grades. Politicians believe these measures are the only way to remedy the perceived weaknesses in the education system and, by the time students are in high school, their performance will dictate whether they will ever be able to actually graduate or attend college. Some people view these high-stakes assessments as the only fair way to judge both students and schools objectively, but others point to the innate flaws in any such assessment to accurately represent student performance. Likewise, various groups debate vigorously whether specific knowledge leads to higher scores, or whether coachable test-taking strategies have a greater impact on student performance. Regardless of which side of the issue researchers argue, there is more or less uniform agreement that student performance on standardized assessments are affected by quite a number of factors seemingly unrelated to intelligence or academic acumen.

Behrendt, Eisenach, & Johnson (1986) summarized the key components that influence student performance by identifying seven key variables unrelated to education itself that strongly impact test scores: higher median family income correlates to higher scores; higher number of households headed only by a female negatively correlates; higher number of siblings negatively correlates; high state population that has completed a four-year college positively correlates; high percentage of state population that has resided in that state for less than five years negatively correlates; high minority composition of the area negatively correlates; and high percentage of population living in urban centers negatively correlates.

Such diverse, non-controllable attributes as race, gender, and socio-economic status, among others, have called many critics to question the fundamental validity and reliability of the exam. Yet despite this controversy, the SAT continues to have significant importance in the college admissions process and the PSAT growing importance in high school placement to academically challenging AP, Dual Enrollment, and Honors courses. "Using PSAT results and other student performance data to help identify students who can benefit from AP courses" (Vaughn, 2010, p. 398) has become typical at most educational institutions, and guidance professionals justify the practice by claiming a high correlation between standardized scores and grade point average (Palin, 2001). A vicious circle has therefore developed among high performers: Students have to perform well on standardized assessments to get into classes that will develop their critical thinking skills, yet oftentimes they haven't yet developed the critical thinking skills they need to do well on standardized assessments.

Proponents of such exams like College Board, the writer of both the SAT and PSAT, defend these assessments and their predictive elements of success in challenging high school and college courses on the basis that they measure innate ability. "When students take the PSAT,"

College Board (2013) states, "They are not required to recall facts—even the math formulas needed are supplied to them. Instead, the PSAT/NMSQT measures reasoning skills—for instance, knowing when to choose one of those math formulas and how to use it to arrive at the correct answer" (para. 1). As such, the company argues, it is a valid and reliable predictor of student academic success across the races and genders, because the concept of reasoning ability being tied to one's gender or race is anathema in the modern world. However, this logic comes under attack in light of actual performance of minorities and women on the exam. "Only a tiny percentage of the high scorers [on the PSAT] are black" (Will the Changes, 1996, p. 62), and that percentage does not equate to the demographic representation of minorities in the United States. In addition, the relatively poor performance of African-Americans and Hispanics on the SAT and PSAT flies in the face of other evidence that suggests academic parity between the groups, such as grade point average. This tendency seems to indicate that the actual construction of the exam, and not a student's fundamental reasoning ability, creates obstacles for one group of students that do not exist or are substantially mitigated for another. "A standardized test may be culturally biased when one group (typically a minority population) performs consistently lower than some reference population—typically, the White population.... A test is considered statistically biased if two individuals (e.g., one African American, one White) who get the same test score nevertheless perform differently on some criterion external to the test, such as school grades" (Freedle, 2003, p. 2).

Some research suggests that the problem is further exacerbated by the socioeconomic status of the families and level of parental education (Hannon, 2015). Often, members of traditionally disadvantaged groups have little recourse for test preparation beyond repetition of old copies of exams made available either at school or in the library. However, even though

exposure to typical test problems can help students prepare for exams, the lack of direction in correcting errors and the mere repetition leads to burnout that negatively impacts test performance more often increased skills that aids it (Rhone, 2006).

Because of the scoring discrepancy among the races, instead of trying to address the underlying issues related to test formulation on its exams, College Board instituted the National Achievement Scholarship Program for Outstanding Negro Students in 1964. Even though blacks represent approximately 10 percent of both the US population and standardized test takers, analysis of student performance yearly indicates that only about 1 percent of the highest scores are achieved by black students. To remedy this perceived bias, College Board instituted this alternate track by which more black students would be recognized annually. However, this program has come under severe criticism by minority organizations and scholars for its insinuation that minorities need a separate scale in order to be viable because when placed side by side with their white peers they cannot compete (Garrigues, 1994). College Board itself seems almost ashamed of this affirmative action, Civil Rights-era program which, while still very much active, has absolutely no mention on its website. Anecdotally the guidance counselors at TFA have never received any information regarding this program from the College Board (R. Hensley & T. Laegeler, personal correspondence, October 1, 2014). Similarly, since standardized test scores are frequently used in the allocation of college scholarship funds, blacks are shortchanged as well. “The predominantly white National Merit Scholarship Program includes \$18 million in corporate-sponsored awards and \$14.9 million in college-sponsored scholarships. In contrast, only \$1.3 million in corporate-sponsored awards and \$1 million in college-sponsored awards were given out in the Achievement Program” (Garrigues, 1994, p. 64). When combined with the fact that the median black household income equals only approximately 59 percent that of its

white counterparts (DeSilver, 2014), the inequality in scholarship distribution becomes even more significant.

However, racial minorities have not been the only group victimized by the supposed bias of the test. Women likewise score more poorly than their male counterparts. This calls into question very readily the predictive claims of the test writers, given that on average women have higher grade point averages in college than men. “To those of us in the academic community who rely on the SATs to guide us in our admissions tasks, it is troubling to discover not only that the tests lead to flawed predictions of female performance relative to that of males but that this problem has been well known to insiders for over a quarter century” (Leonard & Jiang, 1999, p. 376). The problem has become so severe that the American Civil Liberties Union actually took successful legal action against New York State, claiming sex discrimination in the awarding of college scholarship on the basis of SAT scores as they have demonstrably underpredicted female performance (Sheehan & Gray, 1992). Interestingly, this problem has become particularly damaging for women seeking admission to colleges in the last decade. As the number of female applicants has risen and the number of male applicants has plateaued and even started to drop, colleges have begun to raise the expectations for females in order to admit fewer of them. This reverse affirmative action stems from the attempt to maintain equal proportion of the sexes on campus. “The Supreme Court is poised to release its opinion on an affirmative-action case that could forever change the way public colleges and universities consider race in admissions. But even if, as some predict, the justices issue a broad ruling slapping down the use of race in admissions, an open secret in higher education—that many colleges lower their admissions standards for male applicants—remains unchallenged and largely unremarked upon” (Goodwin,

2013, para. 1). So women simultaneously face a gender gap on a test biased against them, and higher standards of admission.

Even more challenging than the apparent racial and sexist bias in the test is stereotype threat—the phenomenon in which individual know about the perceived discrepancies between races or genders and unintentionally self-fulfill them. When minorities hear statistics that indicate that stereotypically they are likely to perform worse than their white counterparts, or women hear comments about how traditionally they will score lower in math than males, they can become anxious and fearful about their success, inadvertently depressing what otherwise could have been a typical score performance (Rhone, 2006; Steele, 2011). Thus stereotype threat occurs when previous underperformance either by the individual or by those similar to the individual in race, gender, or other societally constructed basis creates self-fulfilling prophecies which cyclically lead to continued underperformance for future generations. Steele (2011), an expert in this area, has done research that indicates minorities, though just as rigorously prepared as whites at some of the most elite universities in the country, consistently underperformed across the academic curriculum. Blacks did not achieve the same grades as their comparable white peers, and white women underperformed as compared to white men in advanced math and science classes. Steele hypothesized that the problem was not academic potential or prior training, but rather the threat of living up to the stereotype associated with each group: that blacks are not as intelligent as whites, or women not as skilled in math and sciences as men. To prove his theory, he began conducting tests between these various groups, presenting some activities as having no bias based on race to obviate the perceived stereotype threat, and presenting others as measures of intelligence or mathematical ability, to thereby remind the test-takers of the stereotype that abounds. His findings confirmed his expectations: when

reminded of the negative stereotype associated with their race or gender, participants performed more poorly than the group who had been explicitly informed that race, gender, etc., did not influence the results of the test.

Based on this work, then, Steele (2011) used the concept of stereotype threat as his basis for exploring the phenomenon across its many manifestations. Women in math classes, blacks in critical thinking, whites in athletic competitions, etc., all became party to his research, and all demonstrated the same findings: that a negative stereotype would depress the performance of the stigmatized group if they felt that they might reinforce or validate that stereotype by their performance: “When they were in situations where those stereotypes could apply to them, they understood that one false move could cause them to be reduced to that stereotype, to be seen and treated in terms of it. That’s stereotype threat, a contingency of their identity in these situations” (Steele, 2011, p. 13). He also found that these individuals would often make excuses for themselves before the test—explain they weren’t feeling well, or hadn’t gotten much sleep the night before—almost as if in preparation for justifying why their performance did not live up to the performance of the non-stigmatized group. Therefore, fundamentally, stereotypes related to standardized tests cause many bright minority and female students to withdraw from challenging academic activities not because they are not capable of performing well, but rather because the challenge of not reaffirming the negative stereotype provides too much stress.

Not only are there issues related to the achievement of various groups on standardized assessments, but also some indications suggest colleges try to use them interpretatively in ways that they were not intended, thus creating even more biases that impact admissions decisions. Thus, even if College Board can in the future substantiate its claims that its tests accurately measure students’ verbal and mathematical abilities, those results can still be used invalidly as

indicators of ability that even the test writers themselves don't claim (O'Loughlin, 2011). College Board has provided guidance to what it calls "test data users" to understand that standardized tests are only one imperfect measure of a student, but nonetheless stipulates that even with that inherent uncertainty, it is ultimately the college's responsibility to ensure appropriate utilization of the data such tests provide. There is little research to identify the exact usage of standardized test data by colleges, simply because the colleges themselves are loath to release information about their admissions policies and thus tend to generally indicate that all decisions are made on a case-by-case basis. Yet there does seem to be some evidence that suggests "applicants' entry scores were not considered in relation to other relevant individual factors," especially at schools that receive thousands of applications each cycle (O'Loughlin, 2011, p. 159). However, universities are not the only institutions who would do well to remember that test scores are only one shallow measure of student performance; lawmakers and politicians are allocating millions of dollars and an equally impressive amount of pressure on schools based on these same measures, but do not necessarily understand the limitations of the assessments to accurately predict student achievement.

However, despite concerns that standardized tests will lead to inappropriate college admissions decisions and political policies, or that coaching will skew test results in an inappropriate way, the same argument can be made for any guidance provided to students during the admissions or testing process itself. Should teachers not proofread student essays? Should adults not provide references to students because other students might not have access to those with the same qualifications? Instead of bemoaning the inequality inherent to the college admissions process, test prep naysayers would do better, some claim, to identify the components

of test prep that are most impactful and easily transferrable, and thereby make them more accessible to a broader span of the population.

Some have attempted to do just that. This perceived bias, though continually challenged by the College Board and other proponents of standardized tests, has prompted many reform advocates to “consider the consequences of bias in a measure that is used to determine college admissions and to question the opacity of testing organizations’ release of test data” (HER Editorial Board, 2008, p. 392). Attempts to find the key to success on the tests have been rampant. Everything from the common sense importance of a good night's sleep and healthy breakfast (College Board, 2013), to developing musical ability (Elpus, 2013) or the long-term benefits of breastfeeding (Davis, Gamble, Humphries, Mitchell, & Pendergrass, 2013) have been floated as important strategies that elevate student performance. More extreme suggestions have come from other advocates seeking to calculate minority and female scores on a different, more liberal scale to artificially eliminate the achievement gap (Freedle, 2003), much like the National Achievement Scholarship Program for Outstanding Negro Students program implemented fifty years ago by College Board. Yet few of these suggestions have as much research evidence to substantiate their claims to successfully improve scores as do those in the test preparation industry.

"With the increasing pressure from various individuals and institutions to improve performance, schools and private companies have attempted to respond to the criticism by creating test preparation courses and materials" (Wronkovich & Hess, 1990, p. 17). This growing field has spawned organizations charging top dollar for guaranteed improvements on the test, which in theory should lead to admission to more selective colleges. In fact, standardized test preparation is one of the ugly, open secrets of education that some view as somehow unethical or

unfair, since it is not available to all sectors of the general population (Bond, 2008): However, Bond (2008) acknowledges, that “so long as tests are used in college admissions decisions, employment, and professional certification, people will continue to seek a competitive advantage” (p. 223). In these sorts of courses, part of the focus is content, but even more of it is on strategy and motivation. By learning how to “game” the test, students will be able to improve their scores and thereby increase the odds of acceptance to more selective colleges. He likewise itemizes the very real outcomes of coaching from the college admissions standpoint, as indicated in the figure below.

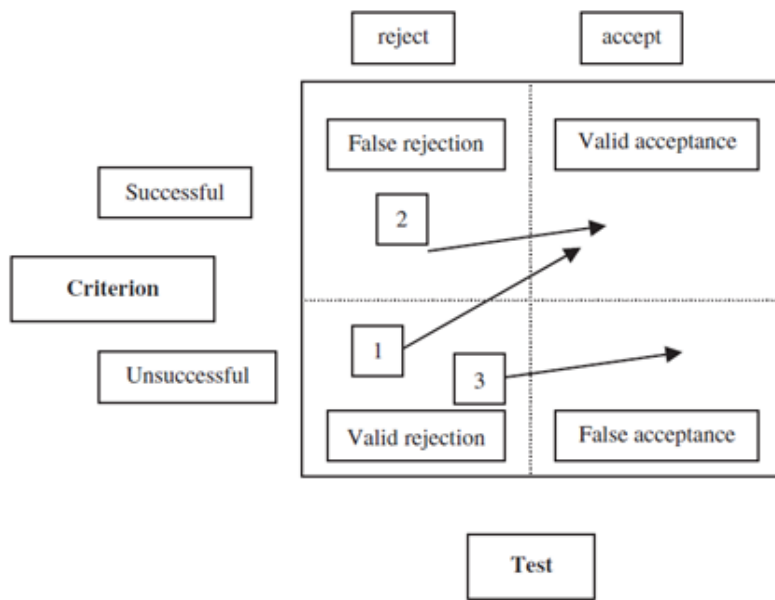

Figure 2. Influence of coaching on college admissions.

Source: Bond, 2008, p. 221

The four quadrants of the figure indicate the three possible outcomes of test coaching. The horizontal axis reflects college admission decisions, with rejection on the left and acceptance on the right. The vertical axis reflects whether a student successfully or unsuccessfully performed in school. The bottom left quadrant, therefore, would represent a “correct” college decision because poor students can expect rejection; the top right quadrant would likewise represent a “correct” college decision because a good student can expect acceptance. Coaching impact is indicated by the three students’ movement from the quadrant they should have been in based on academic performance to the quadrant they were able to achieve based on coaching. Student 1 was a poor student who should have been rejected for admission to college based on his academic performance. However, he sought coaching and after diligent work improved his score sufficiently to perform well on the exam, and thus obtain a college acceptance. The hope with this student is that if he is motivated enough to seek coaching and remains equally diligent in college, this becomes a valid acceptance and thus an appropriate employment of coaching. Student 2 was an excellent student who also initially performed poorly on the exam (and thus would have invalidly been rejected for admission to college) and sought coaching. After diligent work, he too improved his score and was able to obtain the college acceptance he should have had all along. This, too, is an appropriate employment of coaching. Neither of these two scenarios are problematic to most observers. It is Student 3, a poor student who essentially “tricked” his way into college by using coaching to game the test that raises concerns (Bond, 2008).

Large companies like The Princeton Review and Kaplan have become multi-billion dollar companies by critically examining the test and identifying strategic holes that can be manipulated to increase student scores. College Board has consistently insisted that coaching has

little or no effect on student performance, going so far as to release specific publications attacking the claims of test prep organizations to increase final scores significantly (Becker, 1990; Wronkovich & Hess, 1990). To this day, College Board posts specific advice to its test-takers to avoid coaching due to what it claims is the ineffectiveness of the process and generally significant cost involved: "Coached students are only slightly more likely to have large score gains than uncoached students. In addition, about 1/3 of students experience no score gain or score loss following coaching" (College Board, n.d., para. 1). Yet external researchers have not universally corroborated College Board's claims. "Results from a nationwide study showed that students who took private SAT prep classes averaged scores 60 points higher on their SAT tests compared to those who didn't take those classes" (Grabmeier, 2006, para. 2). Field leaders like Becker (1990) have established through statistical meta-analysis that if students find the results of the test relevant to their future success, that coaching can have a positive impact on their performance, particularly in math. However, the actual impact of the coaching varies widely depending on which program is employed. For example, the number of individuals involved in the student cohort negatively correlates to individual results more strongly than the actual intervention employed (Kim & Becker, 2010). There is also a stronger correlation between the amount of time spent in test prep and score improvement than there is in the type of intervention and score improvement (Wronkovich, & Hess, 1990). Thus, it seems clear that coaching which treats content and strategy as complementary components to score improvement can positively influence student performance, and the number of student contact hours on task correlates to the degree of gain (Reynolds, Oberman, & Perlman, 1988; Millman, Bishop, & Ebel, 1965). Likewise, empowering students to understand the test can help them both cognitively with the content they need to master as well as emotionally with the motivation to "beat" the test:

“Students need to be aware of *why* they need to take these tests, *how* they need to take them, *what* the tests require, and the *connection* between the test and students’ own commitment to do well” (Rhone, 2006, p. 235). The emotional component of convincing students they are capable of doing well on the test is, sadly, the most time-intensive part of the process. Students are so convinced that they cannot perform on standardized assessments that the self-defeating attitude they develop all but ensures that they will not succeed (Wronkovich & Hess, 1990).

The effects of coaching differ significantly based on various situations, as Brunner, Artelt, Krauss, & Baumert (2007) identified:

- Motivation. Students who receive coaching for tests that high personal significance (for example, college admission tests for academically motivated students who wish to attend highly selective schools) demonstrate higher score gains than for students who receive coaching on tests that lack that personal significance.
- Content. Students who receive coaching for math are more likely to show score gains than those who receive coaching for verbal content areas like reading and grammar.
- Test types. Students who receive coaching for SAT are less likely to show score gains than those who receive coaching for other test types

So while there is no one absolute panacea that will guarantee score improvement for every student, there is obvious opportunity to use coaching to improve student scores, especially in math, on tests that are of high personal significance to the student, and in smaller groups with more contact areas.

CHAPTER TWO: DESIGN CONSIDERATIONS AND JUSTIFICATION

As TFA has chosen a structural approach to attempt to increase standardized test performance, and research seems to indicate that such coaching can successfully improve scores in various contexts, it is essential to identify what components must be included in the program to achieve the highest score improvement. Scholars have attempted to identify the key elements involved in successful test prep, and the consensus tends to identify consistently the same three areas: familiarity (ensuring that students understand how logistics of the test, like the instructions, time limits, question formats, etc.), content (the type of academic material that will appear on the test), and test-wiseness (using the design elements of the test to improve performance) (Brunner, Artelt, Krauss, & Baumert, 2007). Becker (1990) suggests that test-wiseness is in fact the most critical factor to coaching success, while Wronkovich & Hess (1990) identify the same traits with the addition of anxiety relief/development of self-confidence. The scholarly focus on familiarity, content, test-wiseness, and confidence as the principle indicators of success suggest that they should underpin the development of any content intended to help students improve on any standardized test.² The specific considerations for each of these areas are discussed in depth below:

² Eventually the “Build your own Adventure” manual will provide preparation for students regardless of test-type. In this initial form, it will focus on the ACT because the PSAT and SAT are currently in a state of flux, with the former being totally overhauled effective October 2015 and the latter January 2016. Thus, it makes little sense to develop a lot of new content focused on the prior incarnations of those exams. In addition, initial indications from College Board, the author of both exams, seems to suggest that the changes coming will make the exams much more like the ACT than previously.

Familiarity. The only component of test-prep actually endorsed by College Board is this familiarity approach, in which students know what they are expected to do prior to attempting to do it, thereby decreasing cognitive load and allowing students to more fully engage with the content being assessed. This idea has been validated by research: “In studies with alternate forms of the same test, there is a tendency for the second score to be higher” (Anastasi, 1981, p. 1087). For this reason, College Board provides sample questions and test descriptions for free on its website, as well as more in-depth test descriptions and samples for a fee (College Board, 2014a). Something as basic as administering a pre-test, then, can qualify as coaching and have positive impacts for student performance, because this familiarity approach exposes students to “typical test instructions, items, time limits, and question-and-answer formats by training under authentic conditions” (Brunner, Artelt, Krauss, & Baumert, 2007, p. 112). However, despite this concurrence and the fact that students have access to some materials at no cost, most admit to not making use of these resources at all, or doing so in only a minimal way (Anastasi, 1981). So even the minor test prep that College Board endorses apparently tends to be ignored.

Familiarity also relates to the metacognitive aspect of standardized testing. Metacognitive knowledge relates to how the student conceptualizes his own learning to control and adapt to various situations (Anderson & Krathwohl, 2001). Anecdotally, it appears that the average student has no knowledge of either this concept or the way in which it applies to a new educational experience as it relates to standardized tests (S. Toenges, personal communication, January 25, 2015). For example, when a student sits down to attempt the ACT for the first time, he has to not only be able to answer the questions being posed correctly, but also has to identify the types of knowledge being accessed, switch among various subject matter seamlessly, and not expend precious time in the process.

One way to build test familiarity is through implementation of full-length practice exams for both formative and summative assessment. Yet, the summative application would not be without some risk. Positive results would result in reinforcement of student activities throughout the manual, and thereby increase motivation to continue application of the new strategies. However, negative results might challenge the self-efficacy that the course is attempting to build, causing students to not employ the new strategies they learn. The ability to master new content and repetition of learning strategies that the full post-test would provide justify its use in the manual.

Content. Studies focusing on the impact of coaching identified that success varied significantly with the type of content being taught as well as the background of the students involved in the coaching. Students with stronger academic backgrounds benefit less from coaching than their weaker counterparts, and students exposed to content that most closely resembles the actual test itself will fare better in score improvement (Anastasi, 1981). There is little evidence to suggest that coaching for a specific standardized assessment improves student performance in other cognitive areas or translates to academic success in general. Content approach naysayers argue that any coaching program that employs this approach is fundamentally ruining the value of any standardized test: “Drilling students on a specific set of test items destroys our ability to generalize to the larger domain” (Bond, 2008, p. 217), thus jeopardizing the results of any generalizability a test may claim. However, focusing on the types of content that are likely to appear on a given assessment has demonstrable power in raising scores, especially in math (Brunner, Artelt, Krauss, & Baumert, 2007).

Likewise, finding ways to successfully integrate both content and familiarity (test-taking strategy) into curricular materials can be challenging. This material needs to incrementally

scaffold off prior student learning by adapting to each individual student’s zone of proximal development (Vygotsky, 1997; Cocking, Mestre, & Brown, 2000). This zone represents the optimal area of potential learning for the individual—at a low enough level that students can build from the knowledge they already possess to understand the content without inappropriate levels of frustration, yet at a high enough level that students’ understanding and ability grow as a result of the exercise. Making the material fun and engaging, while simultaneously apt and beneficial, will allow student interest, motivation, and learning capabilities to be harnessed effectively. Despite John Locke’s belief otherwise, students are not absolute blank slates; even infants are born with “sophisticated cognitive architecture” (Cocking, Mestre, & Brown, 2000, p. 3) in place into which new experiences are integrated. Only by scaffolding on these pre-existing mental processes at an incremental and developmentally appropriate rate can students successfully learn.

Lastly, repetition of the new techniques is critical to student retention of the material. The course needs to provide specific homework sets that allow for application of techniques introduced each day, as well as reinforcement of material covered previously.

Test-wiseness. Scholars tend to concur that test-wiseness is the most effective component of successful test prep, especially when coupled with familiarity (Brunner, Artelt, Krauss, & Baumert, 2007). In a seminal article on the subject published 50 years ago, test-wiseness was identified as the primary indicator of student success on standardized assessments—independent of a student’s subject matter knowledge and level of confidence or anxiety (Millman, Bishop, & Ebel, 1965). Test-wiseness refers to “effective problem-solving behavior, such as careful analysis of problems or questions; consideration of all alternatives, relevant details, and implications in arriving at a solution; deliberate rather than impulsive formulation of choice or

solution; and the application of high standards in evaluating one's own performance” (Anastasi, 1981, p. 1091), and are the keys to success in the high-stakes testing environment yet is not something individually discovered by the student commonly unless he has been exposed to some manner of coaching. This one fact alone explains why most strong academic performers in high school do not tend to perform correspondingly well on the SAT, for example. One compelling trial that demonstrates how powerful test-wiseness can be was a 1954 study looking at intelligence tests: randomly chosen students who received coaching scored on average of nine IQ points higher than their uncoached peers (Vernon, 1954). Given that intelligence is supposed to be a fixed attribute at any given point in time, such a score gain is obviously significant.

Ultimately the goal of the program should be authentic, compelling exemplars of the test so that students can not only recognize the specific examples they have seen in prep situation but also extend the concept to any new examples they encounter in the future (Bonds, 2008). Bonds (2008) continues to indicate that “not spending too much time on any one item, familiarity with separate answer sheets, checking all alternatives before deciding upon one’s answer, and, where random guessing is penalized in the scoring process, guessing only if at least one alternative can be eliminated” (p. 219) function as relatively simple behavioral modifications that can have significant impact on student performance. One quasi-experiment in which randomly selected students were provided with general problem solving techniques, such as a review of the types of questions they would encounter and logical reasoning, but *not* provided with any additional content-specific knowledge, made significant gains on tests nonetheless as compared to their non-test-wise colleagues (Millman, Bishop, & Ebel, 1965). Such findings clearly challenge any claims to generalizability that an instrument may proffer. The following table summarizes the test-wiseness guidance that tends to yield the best results:

Table 2. Millman's Outline of Test-Wiseness Principles.

Elements independent of test constructor or test purpose	
<i>Time-using strategy</i>	Begin to work as rapidly as possible with reasonable assurance of accuracy
	Set up a schedule for progress through the test
	Omit or guess at items which resist a quick response
	Mark omitted items, or items which could use further consideration, to assure easy relocations
	Use time remaining after completion of the test to reconsider answers
<i>Error-avoidance strategy</i>	Pay careful attention to directions, determining clearly the nature of the task and the intended basis for response
	Pay careful attention to the items, determining clearly the nature of the question
	Check all answers
<i>Deductive reasoning strategy</i>	Eliminate options which are known to be incorrect and choose from among the remaining options
	Choose neither or both of two options which imply the correctness of each other
	Choose neither or one (but not both) of two statements, one of which, if correct, would imply the incorrectness of the other
	Restrict choice to those options which encompass all of two or more given statements known to be correct
	Utilize relevant content information in other test items and options

Source: Adapted from Millman, Bishop, & Ebel, 1965, pp. 711-713

Other elements of test-wiseness tend to be counter-intuitive and thus hard for students to accept. For example, students have a tendency is to rush through critical material at a fast pace in order to address more of the content and strategy necessary for success. However, the result of this rapid pace may push students beyond their appropriate zone of proximal development and thereby decrease self-efficacy. While this does limit the amount of material that can be covered, it ensures that students will have a much better likelihood of actual retention and application of the material covered, as well as reduces the level of frustration that might reduce motivation.

Confidence. Test anxiety has the tendency to depress student performance due to factors that have nothing to do with a student's ability, and thus is the one domain that even coaching opponents do not challenge as inappropriate (Bond, 2008). Sadly a vicious circle ensues because anxiety and stress in a competitive environment generally depresses standardized test scores, which in turn creates more anxiety and stress for subsequent sittings. There appears to be a connection between familiarity with the test and the confidence with which a student performs (Anastasi, 1981). The explanation proffered by researchers links the experience of taking the same standardized test previously with debunking some of the strangeness or discomfort that artificially decreased student performance initially. Presumably, students may have also developed better test-taking techniques after the experience with prior exams, too. However, test anxiety itself seems to only be increasing across the nation. "Severe cases of test anxiety, however, represent a clinical problem that may require individual treatment" (Anastasi, 1981, p. 1088), and the increased incidence of testing accommodations may be a sign that the growing number of attention-deficit disorder diagnoses may correlate in part to the growing focus on standardized assessments through a student's educational career. Systematic desensitization can help effectively stem the impact of anxiety on performance, but the time required to successfully achieve success can be extensive.

Student performance on standardized tests is affected by much more than innate academic ability. A student's psychological and physiological components affect success on these exams, as well as the cultural environment in which students function. Given that high-stakes exams are supposed to measure innate ability, the idea that something as subjective as confidence could impact performance draws obvious questions about the validity of the scores. Yet one component that appears to be highly correlated to confidence is emotional self-efficacy

(Galla & Wood, 2012). In examining the impact of student perception on objective tests of math ability, Galla & Wood (2012) found that students who believed they were going to perform badly on the assessment did indeed score significantly lower than their less-anxious peers, as illustrated in the figure below.

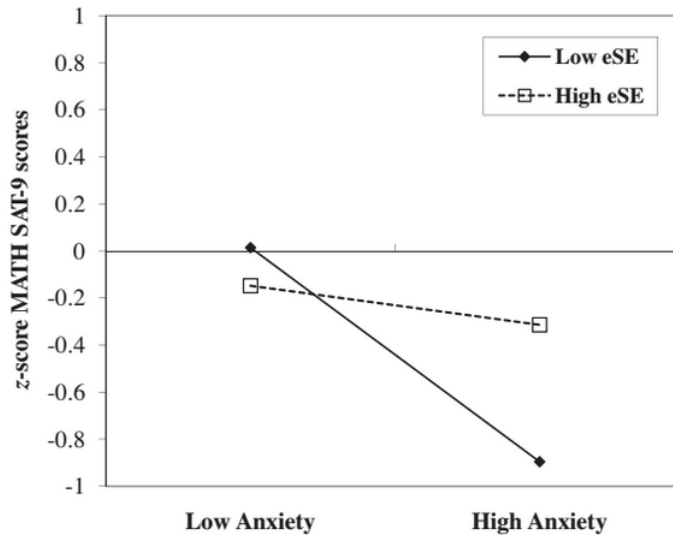

Figure 3. Impact of anxiety level on mathematical scores.

Source: Galla & Wood, 2012, p. 120

Based on these findings, the researchers argue that “anxiety reduces executive cognitive abilities, such as working memory, which in turn explains the negative associations between anxiety and academic performance” (Galla & Wood, 2012, p. 121). Thus, students who suffer from anxiety artificially decrease test performance in a way not concomitant with actual ability. So while a confident student may not have the ability to perform well, an anxious student may possess the ability and just not be able to actually demonstrate that ability. Likewise, students with less confident outlooks have lower expectation of academic success and more test anxiety,

which of course feeds into the same vicious circle of depressing future assessments (Urhahne, Chao, Florineth, Luttenberger, & Paechter, 2011).

The impact that confidence has on performance has grown so pronounced that it has even entered popular culture. The movie *The Perfect Score*, while a critical failure, resonated with high school students facing their anxiety about taking the SAT. A group of six students mastermind a scheme to steal the answers to test because it is the only thing standing in the way of achieving their dreams, and, as the narrator explains, “[The SAT is] not about who you are, it's about who you'll be” (Birnbaum, Glickman, Robbins, & Tollin, 2004). The perception that your score on the test reflects who you are as a student proves unfair, the movie writers suggest, given that scores are negatively impacted by “race bias, gender bias, [and] ‘stereotype vulnerability,’ leading some groups to score badly simply because they are aware that they are expected to. There is the failure to measure creativity” (Lewin, 2004, para. 18).

Digital Manual

Creating a digital manual that students can use independently and obtain easily will reach a much broader audience than other options available. While technological integration into education has become trendy and frequently lauded as the panacea to all societal woes, the use of technology alone does not guarantee any independent learning gains; rather, the manner in which technological solutions are implemented can benefit or hurt the student (Issa et al., 2011). The primary value of technological applications tends to revolve around their multimedia component—the integration of words and pictures in conjunction to bolster student apprehension and scaffold towards learning and retention (Sung & Mayer, 2012). The primary theory that

underpins most relevant research in this field at present is Mayer’s Cognitive Theory of Multimedia Learning, first articulated in 2009, which essential argues that words and graphics in conjunction will more effectively convey learning objectives to students than just words or just graphics alone.

Combining various delivery modalities, then, can substantially increase learning gains when done effectively. This relates to the cognitive load theory. Essentially, humans possess two separate channels through which new information is processed and assimilated: one visual/pictorial and the other auditory/verbal. However, “each channel has predetermined limited capacity to process incoming information” (Issa et al., 2011, p. 819), and thus learning gains can be increased if the instructor leverages both channels simultaneously (Plass, Heidig, Hayward, Homer, & Um, 2014). The figure below diagrams these complementary paths.

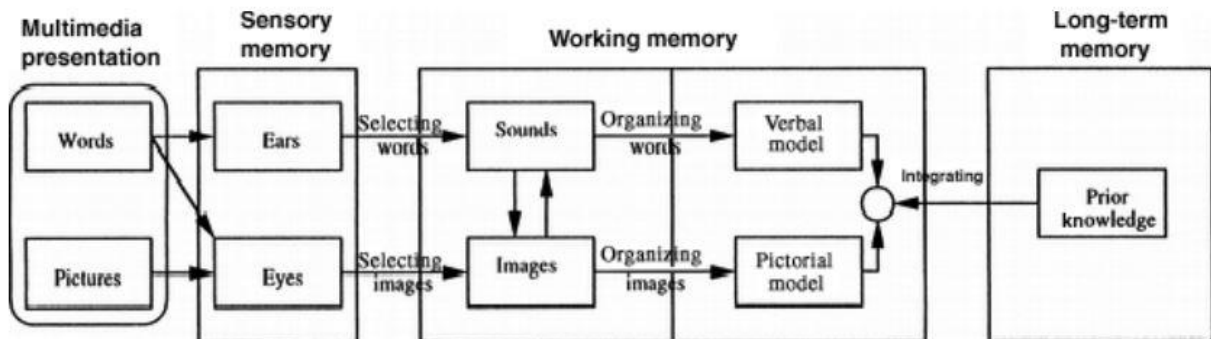

Figure 4. Model of memory as augmented by multimedia learning.

Source: Issa et al., 2011, p. 820

A multimedia-rich, digital manual, therefore, will take advantage of the cognitive paths that pre-exist within the student to reinforce learning in a variety of modalities. Technology can also connect students with a variety of resources to help reinforce learning and demonstrate other applications of knowledge (Cocking, Mestre, & Brown, 2000). The changing nature of educational practice as a result of technologically driven initiatives is illustrated in the following figure:

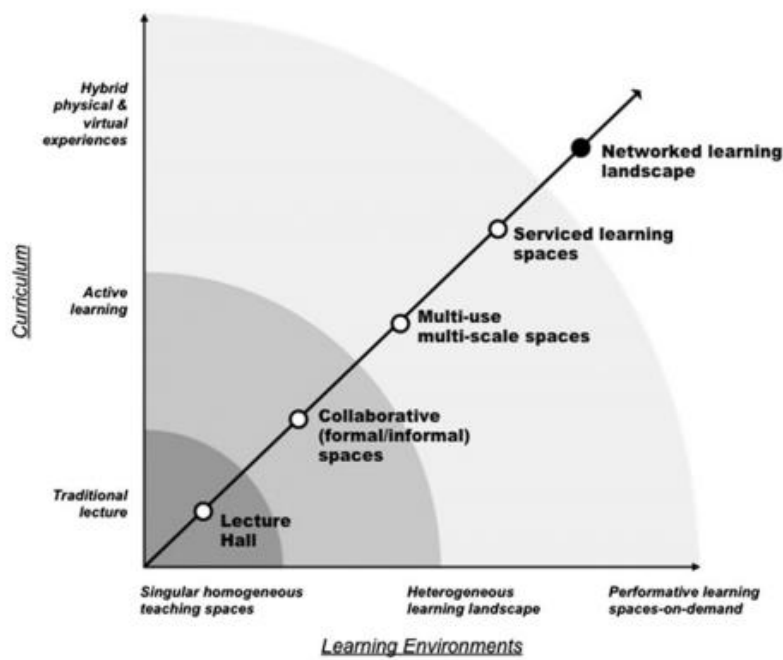

Figure 5. Learning environments as driven by curriculum format.

Source: Nordquist & Laing, 2015, p. 341

Students are no longer functioning solely in a traditional, lecture-driven environment, but the new hybrid spaces into which they are moving require them to adapt to different and sometimes overwhelming environments in an unprecedented way. This shift alone can cause cognitive overload if students don't have support in the transition their learning gains can suffer.

Multimedia-rich, digital paradigms such as the one to be employed in this manual, fortunately,

have been shown to actually reduce the cognitive load at a metacognitive level, because students will have an expert guide and easily accessible interface experience the various components of the exam prior to the actual administration and thus develop extensive knowledge of “general strategies that may be used for different tasks, the conditions under which these strategies may be used, the extent to which the strategies are effective, and self-knowledge” (Anderson & Krathwohl, 2001, p. 43). Perhaps most importantly, such multimedia-rich, multimodal curriculum allows students of varying learning styles to make use of the material in the way most efficacious for them, thereby improving learning gains (Hauptman & Cohen, 2011). While most traditional manuals appeal almost exclusively to visual learners, the online components of a digital manual such as this will likewise cater to auditory and kinesthetic learners as well in a much higher degree.

Yet not all multimedia graphics are equally effective in achieving the desired learning outcomes. Sung & Mayer (2012) identify three types of illustrations: instructive (“directly relevant to the instructional goal”), seductive (“highly interesting but not directly relevant to the instructional goal”), and decorative (“neutral but not directly relevant to the instructional goal”) (p. 1619). While any instructive graphics have been found to have a positive impact on student recall, decorative images had no statistically significant impact and seductive illustrations actually hindered student recall (Sung & Mayer, 2012; Mayer, 2013). Thus, this study suggests that curriculum design should provide instructive graphics primarily with some decorative images throughout to aid in the readability of a given text, but should avoid seductive graphics as they actually work in opposition to long-term learning outcomes. Additionally, making use of instructive graphics coupled with positive affect, using humorous or colorful details, for

example, leads to both higher comprehension and higher transfer performance on learning tasks (Plass, Heidig, Hayward, Homer, & Um, 2014).

Additionally, graphics that have been based on emotional design principles tend to be more effective in achieving student learning goals (Mayer & Estrella, 2014). The concept of emotional design revolves around personifying non-human elements in more human-like ways. It also incorporate more appealing, mostly primary colors. Using these elements results in students generally viewing the material as more approachable and less difficult, and led to statistically significant increases in student gains as demonstrated by pre- and post-test scores (Mayer & Estrella, 2014). It is essential, however, that these graphics don't stray into the area of seductive: "Graphics should be redesigned to be appealing and personified as long as the redesign focuses learners' attention on the relevant aspects of the graphic" (Mayer & Estrella, 2014, p. 17).

Another major method that will require some design considerations is the use of a digital, internet-based manual. Such electronic manuals have become common; however, only rarely are they more than just scanned pages of text that take little advantage of the digital world into which they claim entrance. This manual will not be one of those. Instead, it will be fully interactive with the student and provide frequent opportunity for self-check and feedback. When developing such a manual, it is essential to realize that whatever the delivery method, the pedagogy underlying the material must be sound and uncompromised by the medium and offer students assessment that is relevant and obviously connected to the content (Churches, 2011). As he puts so clearly, "The emphasis is not on the technology, but what the technology allows you to do" (Churches, 2011, p. 35). The myriad of options available in a virtual setting allows students to customize their learning as never previously possible (Nordquist & Laing, 2015), but most online textbooks and manuals are little more than scanned versions of traditional texts. In

an attempt to maximize the benefits an online manual can offer, certain key design elements of online spaces have been articulated by Mayer and generally agreed upon as effective by the research community, as itemized in the table below.

Table 3. Mayer's Principles for Designing Effective Instructional Multimedia Materials

Eliminate external distracters	
Coherence principle	Exclude extraneous words, pictures and sounds
Signalling principle	Highlight essential material
Redundancy principle	Do not add on-screen text to narrated animation
Spatial contiguity	Place printed words next to corresponding graphs
Temporal contiguity	Place corresponding narration and animation at the same time
Encourage learners to establish 'mental frames' for the material	
Segmenting principle	Present animation in learner-paced segments
Modality principle	Present words as narration instead of printed text
Pre-training principle	Prepare/read ahead of time
Facilitate integration of new material with prior established knowledge	
Multimedia principle	Present words and pictures rather than words alone
Personalisation principle	Employ conversational style instead of formal dry style to present words

Source: Issa et al., 2011, p. 820

Review the material in [Appendix C](#) for detailed exposition on how and where the principles were employed.

Closely aligned with the multimedia component of digital manuals is the length of materials. Shorter periods of instruction completed more frequently tend to produce higher levels of student retention than do longer, less frequent periods of instruction, even though the net amount of instructional time remains constant (Mayer, 2009; Issa et al., 2011).

Lastly, a key element needed to inform the design of the manual is that of the authorial persona. The “personality” adopted in conveying the material to students can fundamentally impact how well or how poorly a student responds and adapts to the various content. The way in which a teacher interacts with students in any educational environment can decidedly impact how well learning objectives are achieved. The myriad of activities that the teacher engages in include creation and maintenance of an environment that is conducive to learning, helping children separate significant from insignificant information, connection of diverse learning experiences into one codified whole, and helping children function independently (Sherwood, Kinzer, Hasselbring, & Bransford, 1987). Even though the manual will function independently of a literal instructor when students make use of it, the persona of instructor will be imbedded in it very literally in the style in which the manual is written and the manner in which the video segments are taught. Previous studies in this area have suggested that individuals respond to interactive media very similarly to how they respond to an actual person (Wang, Johnson, Mayer, Rizzo, Shaw, & Collins, 2008). As such, it is beneficial to identify which sort of teacher mannerisms will best encourage student learning and retention and thereby embed those traits into manual.

One major aspect of teacher personality with demonstrated benefit is informality. Rigid, teacher-centered teaching environments that focus on lecture and passive student engagement tend to have diminished student learning gains as compared to those that focus on activity-driven, student-centered activities (Sherwood, Kinzer, Hasselbring, & Bransford, 1987). Likewise, the tone associated with the teacher can seriously impact the student’s unconscious response to the lesson. In what has been attributed to the so-called “politeness effect,” some studies have indicated that learning gains improve for all students working with a polite

instructor (Wang, Johnson, Mayer, Rizzo, Shaw, & Collins, 2008), whereas others narrow the range of affected students to only lower-scoring students showing the benefit (McLaren, DeLeeuw, & Mayer, 2011a). The logic behind this finding seems to stem from the level of confidence a student has. Lower-scoring students know that they are struggling with the content, so therefore a more polite tutor will help minimize the threat of material while simultaneously explaining challenging content. However, a higher-scoring student does not have the same apparent fear of the content, therefore they are more comfortable being challenged in a more direct fashion but a less-polite tutor. However, there is no evidence that the politeness effect actually negatively impacts higher-scoring students; it simply seems to have limited to no impact whatsoever on learning for those individuals (McLaren, DeLeeuw, & Mayer, 2011a).

The use of video in such online learning modalities achieves one specific aim much more effectively than venues that lack a video component: students were able to articulate the problem-solving steps and identify necessary data much more readily than their “text only” peers (Sherwood, Kinzer, Hasselbring, & Bransford, 1987). In fact, the timing of the video components impacted student performance as well: “The opportunity to view a video context prior to reading a related text facilitated performance” (Sherwood, Kinzer, Hasselbring, & Bransford, 1987, p. 103). Text and video should function synergistically and reinforce content through various learning modalities.

CHAPTER THREE:
EVALUATION AND DISCUSSION

Based on my previous experience in the test-prep industry, highly motivated families expect the average improvement in raw numbers to be approximately 150 points on the SAT, 15 points on the PSAT, and 3 points on the ACT when they complete any sort of test preparation program, with the largest increases in math and grammar since the content there is more black and white. In order to evaluate whether the manual as designed achieves this goal, a case study will be used. The draft of the course will be used with a group of students in the fall semester. Pre-test/post-test data will be collected to identify the score improvement, and qualitative survey/interview data will measure student interest, confidence, and enjoyment factors. This feedback will function formatively to allow further refinement of the course, as well as to ensure that the course has the intended impact on test performance.

Evaluation Plan

Identifying the principle questions that will be assessed as part of the evaluation is obviously central to shaping this plan. The following table itemizes the central questions that will indicate success, as far as the quality of the materials and means of presentation as created in the manual:

Table 4. Evaluation Questions / Data Sources and Methods

Evaluation Questions	Possible Indicators/Measures	Data Collection Methods and Information Sources
1. Do students improve at least 150 points on the SAT, 15 points on the PSAT, or 3 points on the ACT?	Pre- and post-test data	- Test score data from initial practice test immediately prior to class - Test score data from full SAT taken immediately subsequent to class
2. Does the teacher believe class time is spent productively?	Teacher expresses confidence in class' success	- Teacher interview immediately after class ends
3. Do students believe they are prepared to take the SAT upon completion of the program?	- Students express confidence in performance - Class sessions are rated as effective by students	- Student surveys administered on final day of class - Student interviews conducted immediately after class ends
4. Is the program being implemented as planned?	- Teacher explains class procedures - Evaluator observations	- Teacher interview immediately after class ends - Evaluator descriptions

In all, a participatory approach, highlighting appreciative inquiry, will be employed in this evaluation. In particular, the value of pluralism will be used because the experience of the student in the classroom might be quite different from the experience of the teacher. By examining both qualitatively, as well as the actual test performance quantitatively, a fuller view of the program's performance can be attained (Fitzpatrick, Sanders, & Worthen, 2011).

These questions represent the true measure of success for the program for a number of reasons. From the stakeholders' perspective, the actual score improvement is the "end-all, be-all" of test prep. Therefore, the program can only be considered successful if students actually achieve a significant improvement on their test scores. However, the various components that impact that score improvement can likewise be assessed. Student self-efficacy, teacher adherence to the implementation model for the course, and teacher input into course design will all

incrementally improve student performance, as well, if they are harnessed successfully. The following table itemizes the various aspects of the course that will be evaluated accordingly:

Table 5. Logic Model

Resources	Activities	Outputs	Short/Medium Term Outcomes	Long-term Impact
<p>In order to accomplish the aims of the program, we will need the following:</p>	<p>In order to achieve the program's goals, we will complete the following activities:</p>	<p>We expect that once completed, this program will produce the following evidence of successful delivery:</p>	<p>We expect that this program will lead to the following changes:</p>	<p>We expect that this program will lead to the following changes in status or life conditions:</p>
<ul style="list-style-type: none"> • One copy of course manual per student • One copy of <i>SAT Official Guide</i> published by College Board per student • A classroom with white board to use weekly • White board erasers, dry erase markers, and other general classroom supplies • 20 hours of instruction time • 12 hours of practice test time • Snacks and candy to be used as incentives • \$625 in tuition per student 	<ul style="list-style-type: none"> • Meet once a week for 2 hours eight times • Review math, reading, and grammar/writing content • Conduct extensive drills to review new content • Simulate actual testing environment in three full-length practice exams • Provide optional workshop for students who want extra practice 	<ul style="list-style-type: none"> • Students will complete all assigned homework • Students will complete all three full-length practice tests • Students will attend all eight class sessions • Students will attend optional workshop sessions as needed 	<ul style="list-style-type: none"> • Students will improve overall score by 150 points • Students will feel more confident about SAT • On the SAT, students will employ strategies taught in class, instead of traditional classroom strategies 	<ul style="list-style-type: none"> • Students will be accepted to more competitive colleges

Instrumentation

Three different instruments will be employed to collect the data required:

1. Course Evaluation Survey. This survey will be delivered on the final day of class. Student will receive a paper copy of the survey, and the instructor will appoint a student to collect the documents and place them in an envelope once the theater leaves the room. Students will then complete the form. Once all students are finished, the designated student will inform the instructor and class will resume. The expectation is 100 percent participation from all students.

This is an appropriate instrument because the survey will allow quick, efficient collection of data from participants on an anonymous basis, making it more likely that genuine responses will be provided. It is also an inexpensive means of collecting data. However, the impersonality of the instrument may lead to incomplete or not thoughtful responses from the students. It is for this reason that the surveys will be followed up with student interviews.

2. Teacher Interview. There is currently only one instructor for this course. That individual will meet with an interviewer/facilitator to get feedback on the course content, structure, and implementation. This interview will last approximately 30 minutes and will be guided by the interview protocol provided below.

This instrument will allow for an in-depth look at both the course content itself and teacher implementation. As there is only one instructor, it would not be logical to construct a survey: obviously there would be no anonymity in such a case, and the approach might seem off-putting to the teacher. Instead, the more detailed responses and personalized attention that the interview provides will allow for a rich depiction

of teacher concerns. These benefits offset the time and cost necessary to complete and analyze the data.

3. Student Interview. Of all the students who just completed the program, three (representing 20 percent of the pool) will be randomly selected to participate in an interview. These students will be offered a \$20 gift card as an incentive to encourage their participation. Each student will meet individually with an interviewer/facilitator to get feedback on the course content, structure, and implementation. This interview will last approximately 30 minutes and will be guided by the interview protocol provided below.

As discussed above, the student survey will provide some but probably not all of the feedback desired. As such, it will be supplemented with the student interview. Time and cost restraints do not permit interviews of every student, so a random choice of three individuals will provide triangulation data without overwhelming the cost-benefit factor of the project.

Instrument 1: Course Evaluation Survey by Student³

Thank you for taking the time to complete this questionnaire. Please be honest in your replies, as these will help us shape future courses. All your answers and details will be held in the strictest confidentiality.

The survey consists of three parts: about you, about the course, and about your teacher.

Part 1: About You

1. Why did you take part in the course?
 - Parent requirement
 - Personal desire to improve on SAT
 - College/Scholarship requirement to improve on SAT
 - Other If Other, please specify: _____

2. How much work did you have to do?
 - Almost No Work
 - An appropriate Level of Work
 - Too Much Work

3. How involved were you in the classroom activities?
 - Not Very
 - Somewhat
 - Very

4. How ready do you feel to take the SAT?
 - Not at all
 - Somewhat
 - Very

³ Based on a course evaluation designed by Smart Survey, an international company specializing in online educational and business surveys (Smart Survey, 2014).

Part 2: About the Course

5. Please indicate how much you agree with the following statements.

	Strongly Disagree	Disagree	Neither Agree nor Disagree	Agree	Strongly Agree
There were clear course objectives					
The procedures and assignments are in line with the course objectives					
I was asked to complete the right amount of work					

6. How would you rate the course on the whole?

- Very Poor
- Poor
- Average
- Good
- Excellent

7. What are the best aspects of this course?

8. How could the course be improved?

Part 3: About your Teacher

9. Please indicate how you feel about the following statements.

	Never	Rarely	Sometimes	Often	Always
The teacher gave clear answers to any questions					
The teacher was considerate					
The teacher was knowledgeable					
The teacher was enthusiastic					

10. What could the teacher do to improve?

Thank you for your help!

Instrument 2: Teacher Interview Protocol

Data	Question	Prompts
Faculty self-reports of demographic data	Tell me a little about yourself and your teaching experience.	Name Age Years teaching Educational background
Faculty self-reports of administrative requirements in classroom	How is SAT instruction coordinated and controlled at your school?	Administration oversight
	Do you teach your test prep class differently than how you teach your regular classes?	If teacher taught prior to implementation
	Are goals and objectives spelled out for your unit? If so, how?	Written handbook Strictness of supervision
	What are the main goals in regards to teaching SAT-related content?	Balance of math/reading content Administrative oversight
Faculty self-reports SAT classroom strategies	How well does the SAT Boot Camp, as currently implemented, achieve its goals?	Frequency Type Utility
Faculty beliefs and values about teaching	What tasks does your department perform? What are the main techniques and technologies used to do these things?	Goal of department Strategies
	Describe your ideal image of teaching the SAT. What knowledge should your students end the class having attained and what sorts of activities does it include?	Content Style Importance
Member Check	Paraphrase what I hear as the central experience, conceptions, beliefs, and attitudes of this faculty person about his/her SAT prep class	

Instrument 3: Student Interview Protocol

Data	Question	Prompts
Student self-reports of demographic data	Tell me a little about yourself.	Name Age Educational plans for college
Student self-reports of SAT awareness	How is SAT instruction coordinated at your school?	Administration oversight
	Do you study/prepare for your SAT class differently than you do your other classes?	Student study habits
	Are goals and objectives spelled out for how well you need to do on the test? If so, how?	Goal setting Managing expectations Strictness of supervision
Student self-reports SAT classroom strategies	How well does the SAT Boot Camp, as currently implemented, achieve its goals?	Frequency Type Utility
Member Check	Paraphrase what I hear as the central experience, conceptions, beliefs, and attitudes of this student about his/her preparation for the SAT	

Limitations

The primary limitation of this evaluation results from the narrow field of stakeholders. Each class has no more than 15 students, so even an approach such as this that seeks 100 percent involvement from all participants will have a small field of data to draw from. Therefore, the statistical significance of the findings can be drawn into question. Also, since the course is only available twice a year and adjustments to content and delivery frequently are implemented in between different iterations, the results from an evaluation of one session may not be applicable to another. Finally, once the manual is fully released to the public, it will not have the benefit of a live instructor guiding the students individually. Instead, the “virtual professor” will have to answer all the questions of users without the benefit of actually knowing them personally and being able to adjust to the unique needs and differences of each. Therefore, the evaluation results determined by the case study would almost necessarily be higher than those actually found by individuals using the materials outside of the classroom setting.

Discussion and Implications

No one manual could ever address the needs of every student for every type of test in every environment. Any curriculum designer must therefore focus on the individual design traits that will yield the biggest impact for the most number of students—a utilitarian approach that will nonetheless not be able to be universal in its usability. However, there is a general consensus in the research about the applicability of test familiarity, content knowledge, test-wiseness, and building confidence as being the principle foundations of test improvement, sadly well beyond the effectiveness of content knowledge alone, and as such can act as the touchstone upon which a strong foundational course can be based. Leveraging Mayer’s Cognitive Theory of Multimedia

Learning in an attempt to create “virtual” classrooms for students who either geographically or financially cannot access them in a “physical” way is therefore the best alternative that could be settled upon.

In regards to the various issues raised in Chapter 1 of this document related to the challenges and at times discriminatory components of high-stakes standardized tests, this manual does help mitigate the impact of them to a degree. Race, gender, and socio-economic status have demonstrated effects on score. While obviously this manual cannot change any of those traits in its users, it can will help minimize their influence. From a socio-economic status, students from traditionally disadvantaged groups tend to suffer because of lack of access to appropriate preparation aids. This economical and easily accessible manual eliminates that barrier. From a race and gender standpoint, the largest challenge is the stereotype threat that seems to reduce scores for minorities and women. The authorial persona adopted in this manual which incorporates the politeness effect and test-wise strategies likewise should minimize the reach of stereotype threat because it intentionally points out the best ways in which to solve such questions while building a student’s familiarity with the actual test itself.

As such, the manual as presently designed addresses the challenges of standardized tests as described in Chapter 1 while simultaneously harnessing the best research-based practices as described in Chapter 2. The result is a product that, with minimal time and effort, will allow any student to improve his performance by allowing a streamlined method to focus only on the content he needs. While at present only a segment of the math manual has been fully developed, the same principles will govern the rest of the manual, which will ultimately expand to include reading, writing, science, and other areas of math, as articulated in more detail in [Appendix D](#). Additionally, the manual currently focuses only on the ACT. However, the content can be easily

adapted to the SAT and PSAT once the College Board releases the specifics regarding the shape they will take after the design overhaul they are currently involved in.

Ultimately no one product can function as a panacea to all the potential woes of a standardized test. However, to allow individual students to suffer inequitably due to factors beyond their control is anathema to the principles of the American education system. This manual, while of course imperfect, can at least start the process of minimizing those factors and helping all students achieve the scores they deserve and thereby secure their college futures on their own terms.

APPENDIX A:
IRB APPROVAL LETTER



University of Central Florida Institutional Review Board
Office of Research & Commercialization
12201 Research Parkway, Suite 501
Orlando, Florida 32826-3246
Telephone: 407-823-2901, 407-882-2012 or 407-882-2276
www.research.ucf.edu/compliance/irb.html

NOT HUMAN RESEARCH DETERMINATION

From : **UCF Institutional Review Board #1**
FWA00000351, IRB00001138

To : **Natalie Holter**

Date : **March 04, 2015**

Dear Researcher:

On 03/04/2015 the IRB determined that the following proposed activity is not human research as defined by DHHS regulations at 45 CFR 46 or FDA regulations at 21 CFR 50/56:

Type of Review: Not Human Research Determination
Project Title: "Build Your Own Adventure" ACT Curriculum Design
Investigator: Natalie Holter
IRB ID: SBE-15-11084
Funding Agency:
Grant Title:
Research ID: N/A

University of Central Florida IRB review and approval is not required. This determination applies only to the activities described in the IRB submission and does not apply should any changes be made. If changes are to be made and there are questions about whether these activities are research involving human subjects, please contact the IRB office to discuss the proposed changes.

On behalf of Sophia Dziegielewski, Ph.D., L.C.S.W., UCF IRB Chair, this letter is signed by:

A handwritten signature in black ink, appearing to read "Patria Davis".

Signature applied by Patria Davis on 03/04/2015 09:12:29 AM EST

IRB Coordinator

APPENDIX B:
MANUAL EXEMPLAR

"Build Your Own Adventure" ACT Prep Manual – Math Edition

By Natalie Holter

© 2015

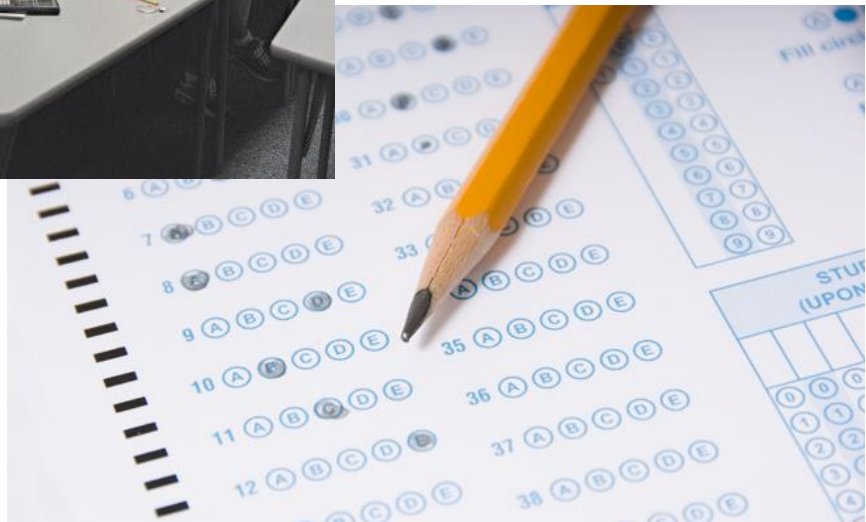
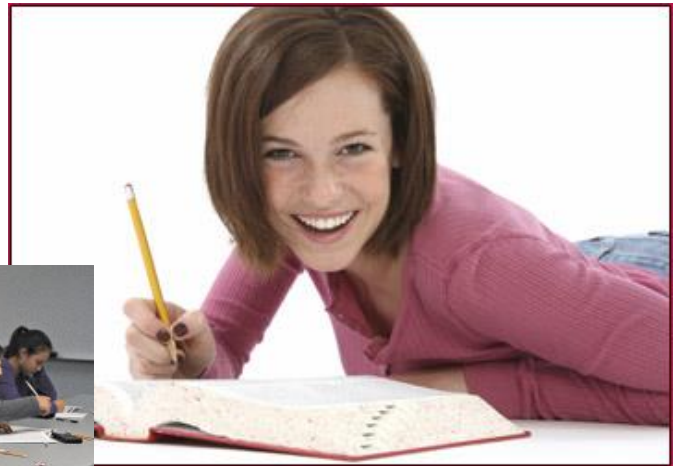
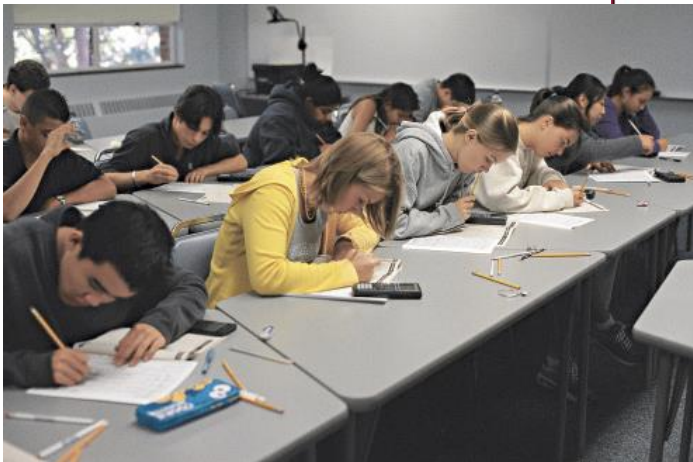

Welcome!

So you have to take a standardized test, huh? You have come to the right place. This digitally enhanced, comprehensive manual has been created so that it can be customized for the most important person who could ever use it: YOU! Even though the SAT, PSAT, and SAT are very different tests, the reality is that they cover the same content with minor exception. The rules of grammar don't change just because you're taking a different test, right? So why buy three different books?

It is that logic that framed the creation of this "Build Your Own Adventure" concept. If you need a primer on all aspects of the tests, everything is here. You can start from the beginning and just work through the sections in order. But what if you are solid with geometry and just need a little help with some the math questions dealing with permutations? We can do that, too. In fact, you can take the practice diagnostic tests at the beginning of the book to find out exactly which topics are your weakest, and each question can automatically link you to the page in the manual you need to review in order to get the content you need. Sounds easy, right? It is! You will even find additional tests at the end of the manual on which you can prove all your newly honed test-taking skills. The key to improving your performance on these pesky tests is at your fingertips!

The fundamental basis of improving scores on tests like these relies upon two primary thrusts: content knowledge and strategy know-how. Thus, woven throughout all the chapters you will find both pieces seamlessly integrated. In that way, you will understand the mechanics of how to solve problems, as well as the best, most efficient way to derive the right answer based on how the test is written. Along the way there are some other tips to help:

- *Some Friendly Advice.* These boxes discuss some helpful hints to content and strategy that will allow you to move through the test like a pro.
- *Misconception Alerts.* The most common mistaken ideas that plague test takers are identified and explained. Be victim no more!
- *Digital Professor.* Reading about how to do solve problems is great, but some people benefit from seeing and hearing the process directly. That is why throughout the text, clips of exactly that have been provided. Hearing the dulcet tones of your teacher's voice as you watch the questions being solved will undoubtedly help you master the content in no time.
- *The Nitty Gritty.* The best approach to each section in 10 steps or fewer.

So get ready: your journey to standardized test success has begun!

About the ACT

The ACT is an awesome test, and, no, I am not being paid to say that. While no test is perfect, this one comes darn close by balancing the knowledge that a typical high school student should have learned in high school with a reasonable testing scenario. In addition, it is something that you can improve by understanding the content focused upon and the way the test is written. It's hard to get better than that.

While some people may argue that standardized tests measure innate ability and thus cannot be improved through study, nothing could be further than the truth. There is no such thing as a test that you can't study for. In fact, your ACT score can definitely be improved, but not by memorizing content alone. It is very important to know HOW the test operates and to develop a customized strategy that takes advantage both of its design and your personal strengths. Here are some of the most important items that you need to know:

- Test Structure. The ACT is long—there's no denying that. The actual breakdown of sections is as follows:

Test	Questions	Time Allotted
English	75 questions	45 minutes
Math	60 questions	60 minutes
Reading	40 questions	35 minutes
Science	40 questions	35 minutes
Writing (optional)	1 question	30 minutes

Unlike other tests, the ACT is nice in that it clumps content into one section, and doesn't force you to constantly jump back and forth between the same subjects repeatedly throughout the test. That means that once you complete the math section, you're done with math. Once you complete reading, you're done with reading. This mirrors the typical high school day, so our brains like it. It's good to keep your brain happy.

- Timing. When most people look at the actual breakdown of the test, their first response is something to the effect, "How can they flipping expect me to answer 75 questions in just 45 minutes?!?" The answer: They don't. You will run out of time on this test. If you don't know that, the first time the proctor announces you have five minutes left and you're only halfway through a section, you will freak out. However, this is NOT a test that requires you to answer every single question perfectly to get a great score. Instead, accuracy matters much more than quantity. While, of course, you want to put down as many answers as you can to get the highest possible score, you want to make sure that all the answers you put down are correct. It's not a compliment to be told, "Congratulations! You got the wrong answer really fast!"

- **No Blanks Allowed.** Even though you're not going to necessarily be able to work every single question in the time allotted, you should not leave anything blank. That is simply because there is no penalty for wrong answers on this test. Thus, any question you either don't have time to work or simply don't like, you will fill in a random answer. However, because of the way the test is designed, it's not ideal to simply Christmas tree those responses. The test writers try to have each answer choice equally represented across the entire test. Thus, you should pick an answer choice and consistently bubble it straight down on your answer sheet. This "Magic Letter" statistically will be the right answer 25 percent of the time. Not bad for a random guess, right? If you were to just randomly put down answers for these questions, you might get lucky and get everyone right, or (more likely) you might miss them all. I'll take the 25 percent, please.
- **Process of Elimination.** Even though this is a knowledge test in the sense that you have to know the basic rules of grammar, math, etc., to get a perfect score, it is also a standardized test which employs multiple choice answers. That means you can take advantage of that format. For example, what if the following question appeared on the test:

37. What is the capital of La La Land? _____

That would truly be a knowledge question because it would expect you to fill in the correct answer from memory and, if you don't know the exact city to name, you are screwed. However, that is not how the ACT asks questions, is it? On this test, the question would appear as follows:

37. What is the capital of La La Land?
- A) Washington, DC
 - B) Paris
 - C) London
 - D) Tokyo
 - E) The weird one

Amazing how all of a sudden we're all geography experts, right? You didn't know the correct answer is E because you suddenly remembered the name of the capital of La La Land (which is of course not real. Look a map sometime, people!). You knew because it was the only option that wasn't obviously wrong. That aspect of the test is called Process of Elimination, and it is worth its weight in gold. Look for obviously wrong answers, and guess from what is left. That simple.

- Pacing. Just because you're not going to get to every single question doesn't mean that you shouldn't go in with a strategy. While the accuracy of the questions you answer is paramount, if you only answered one question and then used your Magic Letter on the rest, you still aren't going to get a perfect score. You have to answer enough questions that you can get a healthy number of questions right. Thus, inside each "Intro" chapter of this book you will find guidance about how many questions you need to answer to get yourself into the range of a specific score.

So what should I do now? I'm glad you asked. If you just need to make a few tweaks here and there, you go to the appropriate content area in this manual and focus on just those topics. There will be detailed explanations about how to do the questions and more practice. However, if you need a more comprehensive approach to the test, there are two competing schools of thought:

1. Review everything. If your individual scores on English, Math, Reading, and Science are pretty close together, you are looking to improve your overall score, and you have at least a month or two to dedicate to the process, you want to start from the beginning and work through to the end, reviewing all the content. The overall Composite score is an average, so improving all the separate pieces will cause the average to float up, too. However, this much work takes time, so don't leave it to the last minute.
2. Best and worst. Left it to the last minute, huh? Well, then you are probably going to need to opt for this option, in which you focus just on your best section and your worst section. The logic is that since the Composite is an average, the sections that impact it the most are your best (which you can improve because it's probably the area you most enjoy) and the worst (which you can improve because you have the most available points to earn). The ones in the middle aren't going to matter much anyway. If you are under a time crunch, this is great because in theory it requires half as much time as the option above. However, if your scores are pretty close together, it can be tough to decide which qualifies as your best and worst.

Ultimately, whichever option you go with, you have to know where you're starting so that you can make an informed decision about what to do next. That is the point of the first diagnostic test. So follow the directions on the next page and establish a baseline for yourself.

Math Test

Fractions and circles and means, oh my!

Test	Questions	Time Allotted
English	75 questions	45 minutes
Math	60 questions	60 minutes
Reading	40 questions	35 minutes
Science	40 questions	35 minutes
Writing (optional)	1 question	30 minutes



Math Introduction

Ah, math. You either love it or you hate it, right? The majority of the questions revolve around algebra (about 50 percent of the section) and geometry (about 40 percent of the section), but some of the content comes from material you learned in elementary school so we need to dust off the cobwebs a bit, too. There will also be a handful of more advanced questions, such as trigonometry, imaginary numbers, etc., but only a few and usually near the end, so depending on your speed you might not even see them.

Here are the basics you need to know about this section:

- It is the second multiple choice section. This means that you will still be relatively fresh when you hit it. However, it is also 60 minutes long, and since you hit it straight after the first section with no break, you might be feeling some mental fatigue. As Taylor Swift would say, shake, shake, shake it off...
- Timing is tough. The test designers don't intend for you to finish, and most people won't. Don't let any one question hold you up.
- Pacing. The timing issue means that you should have a plan about how many questions you should answer to get the score you want. Use the chart below as a guide:

Score	Correct Answers	Score	Correct Answers	Score	Correct Answers
36	60	27	45	18	26
33	55	24	38	15	15
30	51	21	33	12	8

Unless you're perfect, you should plan on doing a few more questions than listed above. Most people should try to get through the first 45 questions before they start using their Magic Letter. Remember: No blanks allowed!

- Calculators are allowed. This is the only place on the test where you are allowed to use a calculator, so make sure that you have it fully charged or bring an extra battery, just in case. You should also do all of your practice in this manual with the calculator you plan to use on the day of the test. You can waste a lot of time just trying to figure out how to calculate something otherwise.

- No formulas. This is one way that the ACT demonstrates that it is a knowledge test—the test writers expect you to come to the test with certain formulas memorized. The formulas you need to know are as follows:

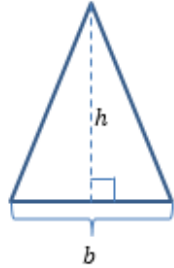

$$A = \frac{1}{2}bh$$

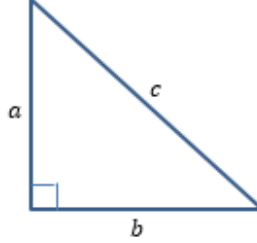

$$a^2 + b^2 = c^2$$

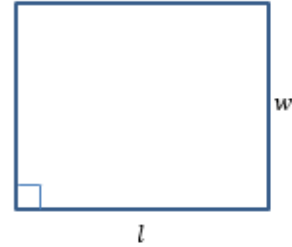

$$A = lw$$

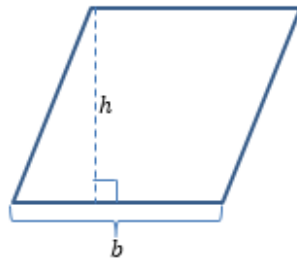

$$A = bh$$

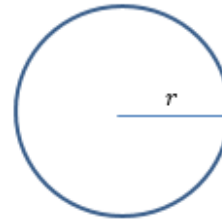

$$A = \pi r^2$$

$$C = 2\pi r$$

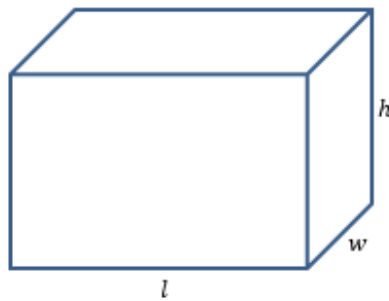

$$V = lwh$$

$$SA = 2lw + 2lh + 2wh$$

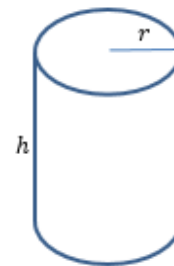

$$V = \pi r^2 h$$

$$SA = 2\pi r^2 + 2\pi r h$$

- Order of Difficulty. The questions on the math section get progressively harder, so use the question placement as a guide. The first 20 questions should be pretty straightforward; the last 20 questions should be pretty tough. This yields two counterintuitive strategies:

- The first few questions are probably going to seem very easy to you, which ironically means that you are VERY LIKELY to miss them due to careless mistakes unless you intentionally slow yourself down. Therefore, make sure you double check at least the first 10 to protect yourself.
- The last few questions are going to be tough. From a timing standpoint, most people don't even get to them, but if you do make sure you do NOT choose the easy, obvious answer. If the question were that easy, it wouldn't be at the end of the section.

So let's get going, shall we?

ACT Math Diagnostic Test

The following math test should be used to determine not only your current score, but more importantly the areas where you need to improve. Therefore, try to take the test under "accurate if simulated conditions," meaning all in one sitting and not spending any longer on a given section than is allotted. After you complete the test, score your test using the instructions that follow it.

Each question on the test has been explained in a "Digital Instructor" file that you can access page by page. Review each question you missed carefully. While the test writers will never ask the exact same question again, they will ask something very similar in scope and content. One of your best strategies to improve is developing familiarity. Make sure that by the time you are done, if you were to take the test again, you would accurately answer each and every question not because you remember the right answer, but because YOU KNOW HOW TO DO IT.

To further aid your improvement, you will also find page references and links from each question on the test to the corresponding content in this manual. If you find you continue to have difficulties with the question, follow the link to the manual and do some extra review.

Good luck!

Algebra

As explained in the Math Introduction previously, the breakdown of math content is roughly one-third Algebra, one-third Geometry, and one-third everything else (data, functions, statistics, trigonometry, etc.). Fortunately for us, though, there is one simple strategy that applies to nearly every Algebra question and a good number of questions in the other areas as well:

PLUG IN!

If you don't know something, make it up.

What the heck does that mean, you may ask? Simply this: solving questions using variables can be hard not because we don't know how, but because we can make a mistake and have no idea that we are off track. For example, do you know if $x + y = 6$? It could be true, but that's about all you can say. What if instead you were asked does $4 + 5 = 6$. Of course not, you could say right away. That is why Algebra sucks—not because it's hard, but because it's uncertain. Thus, whenever you have a question featuring variables, you can just make up a number and solve instead of trying to write out equations. Let's look at an example.

Plugging In With Variables

You will see question after question on the ACT with algebraic expressions as the answer choices. Consider the following:

18. Bobby had a collection of s stamps, 8 fewer than his sister Rachel has. If Rachel receives 3 more on her birthday, in terms of s , how many stamps will Rachel have then?

- A) $s - 8$
- B) $s - 3$
- C) $s + 3$
- D) $s + 8$
- E) $s + 11$

The idea of having s stamps is crazy, right? Don't try to write out an equation or think about it complex terms: just make up a number. Let's just say Bobby has 10 stamps, or $s = 10$. Once you pick a number, just walk through the question doing whatever math the question tell you to do. Bobby has a

collection of 10 stamps, 8 fewer than Rachel. Okay, that means that Rachel must have 18 stamps. She is then going to receive 3 more for her birthday (wow—what else would a girl ever want, right?), which means she now has 21 stamps. Cool, especially since that answers the final question. (By the way, see where it says, “in terms of s ”? Great. Scribble it out. Never has there been such a waste of ink on the test. It is just there to mess with you.)

Since I know that the final answer should be 21, I need to find that in the answers. But there aren’t real numbers down there, right? There are “algebraic expressions.” No worries. We just substitute in the number we made up for the variable and look for our answer. Since we said that $s = 10$, we can go answer by answer.

- A) ~~$10s - 8 = 2$~~
- B) ~~$10s - 3 = 7$~~
- C) ~~$10s + 3 = 13$~~
- D) ~~$10s + 8 = 18$~~
- E) ~~$10s + 11 = 21$~~

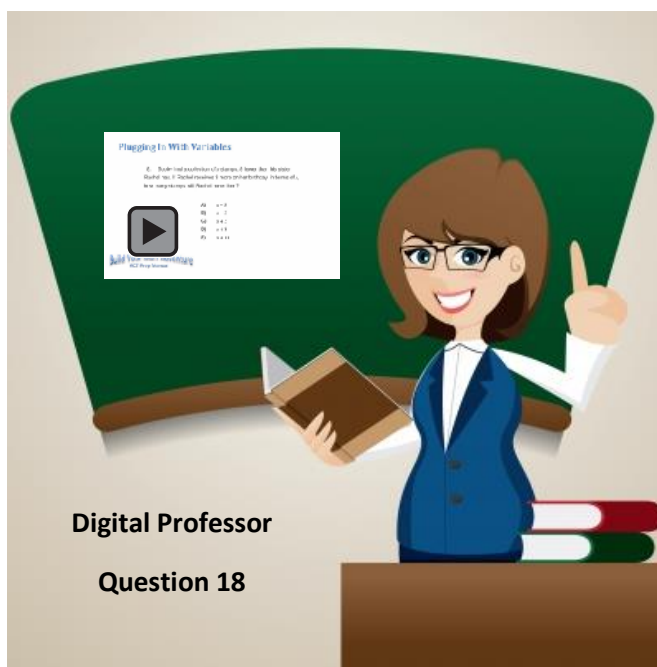

Look at that: answer choice E gave the right answer. That’s how we know it must be right. Pretty cool, huh? Let’s look at another one.

48. What is the average of $2x$, $\frac{3}{2}x + 4$, $2x - 7$, and $\frac{5}{2}x - 1$?

- A) $8x - 4$
- B) $\frac{12x-4}{2}$
- C) $\frac{6x-2}{4}$
- D) $16x^2 - 28$
- E) $2x - 1$



SOME FRIENDLY ADVICE

One of the most beautiful things about plugging in is that you are in COMPLETE CONTROL of what numbers to use. In this example, since there are fractions, it is a great idea to use an even number because the math will work out very easy. So the moral of the story is if you can use any number, let's not use π . And if you pick a number and the math starts to get messy, just change it. I won't tell if you won't.

Certainly more annoying, what with the fractions and all. But the variables all over the place tells us to just make up a number and figure out the average. So let's make up something for x . How about $x = 2$.

We can plug in that 2 everywhere we see an x , so our four terms become

$$\begin{aligned}2x &= 2(2) = 4 \\ \frac{3}{2}x + 4 &= \frac{3}{2}(2) + 4 = 3 + 4 = 7 \\ 2x - 7 &= 2(2) - 7 = 4 - 7 = -3 \\ \frac{5}{2}x - 1 &= \frac{5}{2}(2) - 1 = 5 - 1 = 4\end{aligned}$$

It's much easier to find the average of 4, 7, -3 , and 4 than it is to find the average of four algebraic expressions, right? We just add up the values [$4 + 7 + (-3) + 4 = 12$] and then divide by how many terms we have (4). So the answer is $\frac{12}{4} = 3$. (Click here if you want a more in-depth review of how to find average.) With that, we just go through the answer choices until 3 spits out:

- A) $8x^2 - 4 = 16 - 4 = 12$
- B) $\frac{12x^2 - 4}{2} = \frac{24 - 4}{2} = \frac{20}{2} = 10$
- C) $\frac{6x^2 - 2}{4} = \frac{12 - 2}{4} = \frac{10}{4} = \frac{5}{2}$
- D) $16x^2 - 28 = 16(4) - 28 = 64 - 28 = 36$
- E) $2x^2 - 1 = 4 - 1 = 3$

Look at that. It must be answer choice E again, because it is the only answer that worked out to 3.

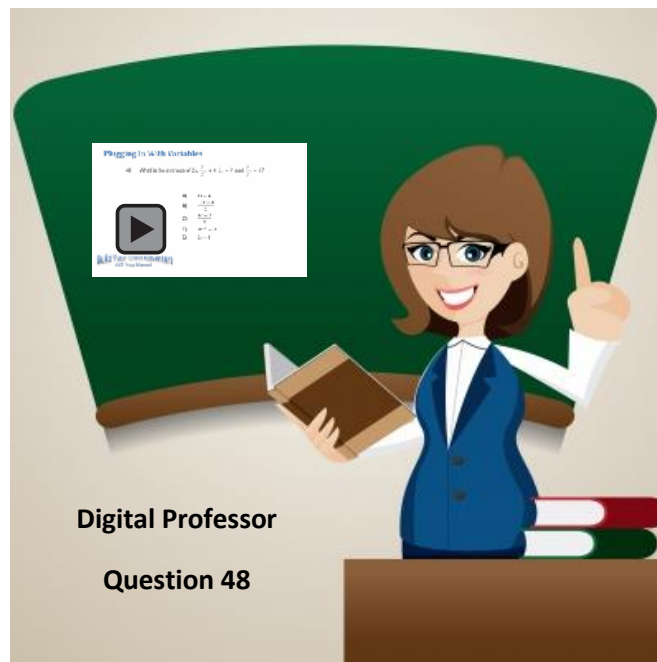

Every once in a while, a question will have more than one variable in it. No worries. Just plug in more than once. This is a typical question you'll see:

22. How old will a person be in exactly 3 years if exactly a years ago the person was b years old?

- A) $b + 3$
- B) $b - a - 1$
- C) $a - b - 3$
- D) $b + a + 1$
- E) $b + a + 3$

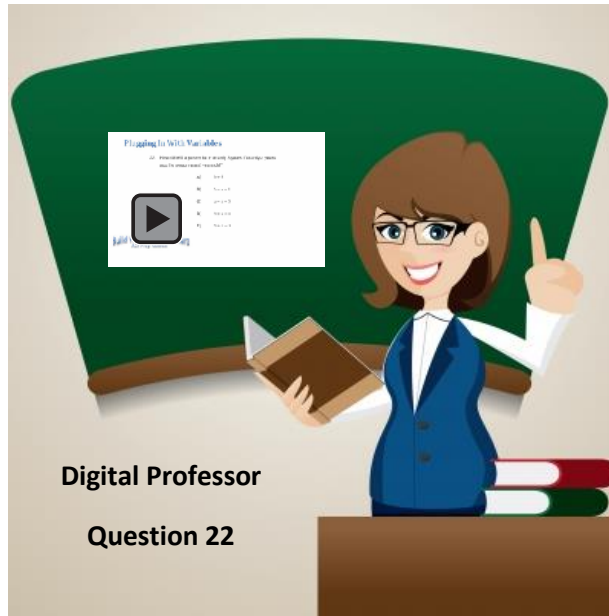

The typical person reads and rereads this question before they have any clue what they are supposed to do. But you're not the typical person, are you? You are immediately going to see the variables everywhere and just make up some numbers to figure it out.

So, let's assume that $a = 5$ and $b = 10$. That means the question really reads "How old will a person be in exactly 3 years if exactly 5 years ago the person was 10 year old?" That's much easier, right? If you were 10 five years ago, then you must be 15 now. That means that in 3 more years, you will be 18. Done. So let's go find it in the answers:

- A) $\frac{10}{b} + 3 = 13$
- B) $\frac{10}{b} - \frac{5}{a} - 1 = 4$
- C) $\frac{5}{a} - \frac{10}{b} - 3 = -8$
- D) $\frac{10}{b} + \frac{5}{a} + 1 = 16$
- E) $\frac{10}{b} + \frac{5}{a} + 3 = 18$

Look at that. The answer is E again.

Wait a minute, you're probably thinking. Is the answer going to be E every single time one of these questions pop up? You wish. The people who write standardized tests know that this little trick exists, so occasionally they will sneak in a couple of answer choices that could work if you happen to pick the right number. Not sure what that means? Let's look at another example.

16. If x is an integer, which of the following must be an even integer?

- A) x^2
- B) $5x$
- C) $x + 3$
- D) $2x + 4$
- E) $\frac{x}{2}$

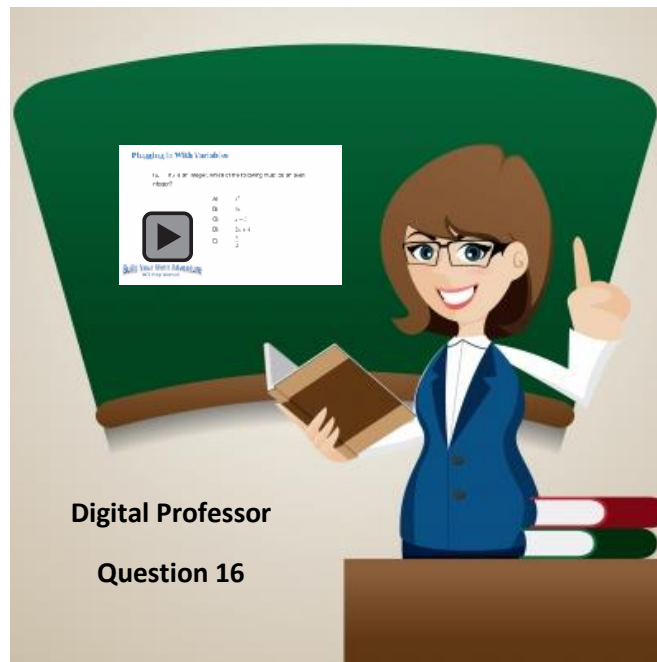

So you see variables throughout the question, and that means to plug in. So let's just pick a number; $x = 2$. We'll plug in 2 wherever we see an x , and we want an even number to spit out.

- A) $\overset{2}{x}^2 = 2^2 = 4$
- B) $5x$
- C) $x + 3$
- D) $2x + 4$
- E) $\frac{x}{2}$

Right off the bat we're in luck, right? Obviously A is the answer, or so you think before your eyes happen to fall on B:

- A) $x^2 = 2^2 = 4$
- B) $5x = 5(2) = 10$
- C) $x + 3$
- D) $2x + 4$
- E) $\frac{x}{2}$

You can't have two correct answers; why are both A and B even, then?

That is possible because of how the question is written. Every once in a while, more than one answer choice will work based on what number you happen to plug in. That is normal, but nonetheless annoying, because it means that there is only one rule when it comes to plugging in:

YOU MUST CHECK ALL ANSWER CHOICES!!!

It's not too often that you see THREE exclamation points at the end of a sentence in this manual, so that must mean this is really important. If you don't check all answer choices, you wouldn't notice that B worked, too, and what if that was the right answer?

So let's get back to the question. We have already figured out A and B; let's plug in on all the rest and see what we can figure out.

- A) $x^2 = 2^2 = 4$
- B) $5x = 5(2) = 10$
- C) $x + 3 = 2 + 3 = 5$
- D) $2x + 4 = 2(2) + 4 = 4 + 4 = 8$
- E) $\frac{x}{2} = \frac{2}{2} = 1$

Now that you have worked all the options, you see that A, B, and D are all even and are therefore possible answers. That also means that we can eliminate C and E, and that's awesome

because once we kill an answer it stays dead—we do not resurrect it. So what do we do now? Easy! Just plug in another number! Let's see what $x = 3$ gets us.

A) $\cancel{x}^3 = 3^2 = 9$

B) $5\cancel{x}^3 = 5(3) = 15$

C) $\cancel{x + 3}$

D) $2\cancel{x}^3 + 4 = 2(3) + 4 = 6 + 4 = 10$

E) $\frac{\cancel{x}}{2}$

With our next round of plugging in, we see something interesting happen: A and B come out odd this time, and only D stayed even. Aren't you glad you didn't stop at A? You would have gotten the wrong answer even though you did everything right. But now we know that D has to be the answer because it is the only one that was always even.

Checking all five answer choices is the only absolutely non-negotiable rule when it comes to plugging in, but there are a handful of other tips that will make your life easier if you use them:

- Pick easy numbers, like 2 or 10. If you can plug in anything you want, use something that makes your life easy.
- Just pick a number. Students tend to waste a lot of time thinking about what the perfect number to use could be. Don't do it—just pick something to get started. You can always change it if the math starts to get messy.
- Avoid using 0 and 1. These numbers just have too many special rules about them.
- Avoid using numbers that are already in the question. Ignoring this one will usually lead to more than one answer choice working, thus requiring you to plug in a second time. So, if the question already has a 2 in it, don't plug in another 2. If the question talks about a dozen, don't use 12. If it talks about an hour, don't use 60. You get the idea.



Misconception Alert

Be sure to watch out for questions that ask "what *must* be true." Most of the time people pick answer choice A because it happens to work with the first number they plug in. More often than not you will have to plug in more than once to get the correct answer, and the correct answer will be something other than A.



It can be creepy and downright frightening how easily this process works, but that's also why it is beautiful. IT WORKS. Anytime you see anything you don't know, make it up.

Advanced Topics

Trigonometry

Yikes, that sounds scary, doesn't it? Fortunately for us all, it is not nearly as bad as it seems. These questions all revolve around one specific acronym that sounds like it should appear in an American History textbook instead of a Math classroom:

SOHCAHTOA

No, that is not the name of the Native American who guided Lewis and Clark on their miraculous westward journey. This is instead an awesome acronym that allows you to solve many trig questions correctly with minimal effort.

So what does it mean? Glad you asked.

SOHCAHTOA provides a simple way of remembering the ratio of sides for the three basic trig functions: sine, cosine, and tangent. Each letter stands for a specific word:

S-O-H tells you that

$$\text{sine} = \frac{\text{Opposite}}{\text{Hypotenuse}}$$

C-A-H tells you that

$$\text{cosine} = \frac{\text{Adjacent}}{\text{Hypotenuse}}$$

T-O-A tells you that

$$\text{tangent} = \frac{\text{Opposite}}{\text{Adjacent}}$$

Let's consider a standard right triangle, pictured below, with sides of 3-4-5. We will also mark one of the non-right angles inside the triangle as x . Applying what we know about SOHCAHTOA, we can identify the exact values of sine, cosine, and tangent for this triangle:

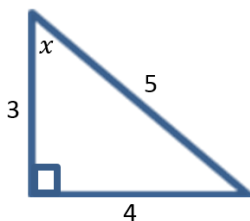

$$\sin x = \frac{\text{Opposite}}{\text{Hypotenuse}} = \frac{4}{5}$$

$$\cos x = \frac{\text{Adjacent}}{\text{Hypotenuse}} = \frac{3}{5}$$

$$\tan x = \frac{\text{Opposite}}{\text{Adjacent}} = \frac{4}{3}$$

There's nothing else to it. So let's look at another example.

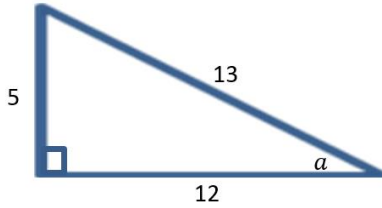

$$\sin a = \frac{5}{13}$$

$$\cos a = \frac{12}{13}$$

$$\tan a = \frac{5}{12}$$



Misconception Alert

Many students get confused about which side is the adjacent and which side is the hypotenuse when the angle is in between them both. Just remember—the hypotenuse is ALWAYS the longest side of the right triangle. The adjacent, therefore, must ALWAYS be one of the legs.



With the basics established, it's not uncommon at all for the test writers to extend the basics into a few tougher scenarios. For one, you can be given one of the trig functions and then asked to solve for a side of the triangle. For example, consider this problem:

27. For $\triangle ABC$, shown below, $\sin \alpha = \frac{3}{5}$. What is the length of AB ?

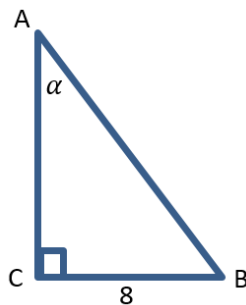

- A) 3
- B) 5
- C) 10.5
- D) 13.3
- E) 15

We can still apply SOHCAHTOA to this situation. Looking at the triangle as pictured, we can determine that $\sin \alpha = \frac{8}{AB}$. But the question stated that $\sin \alpha = \frac{3}{5}$. While at first this seems to be a contradiction,

it really isn't. You just need to realize that trig functions are just ratios. Just like you can say that $\frac{1}{2} = \frac{2}{4}$, you can apply the exact same logic in this situation. We know that $\sin \alpha$ is equal to both $\frac{8}{AB}$ and $\frac{3}{5}$, so we just need to set them equal to each other and solve.

$$\frac{8}{AB} = \frac{3}{5}$$

Cross multiplication yields

$$3 \cdot AB = 8 \cdot 5$$

Divide both sides by 3, and you derive your answer.

$$AB = \frac{40}{3} = 13.3$$

Thus, the credited answer here would be D.

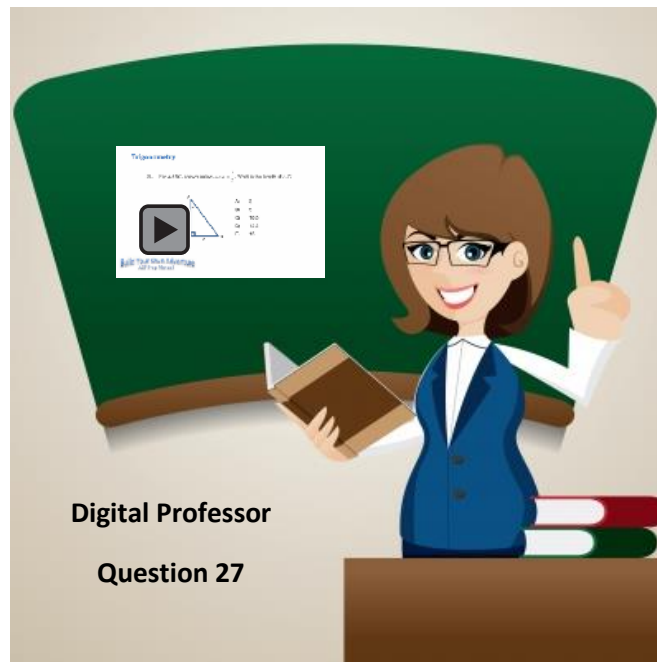

Another common type of question you will see involves real-world application of the trig functions. Strangely enough, they almost always tend to involve burning buildings, ships lost at seas, and balloons floating in the air. Go figure. The hardest part of these problems is accurately creating the drawing to reflect the situation described (if one isn't given to you) and then deciding which trig function is involved. Let's take a look at one as an example:

43. The fire department arrived on the scene of a building fire. In order to reach the apartments on the top floor, the fire fighters fully extended their 50-foot ladder at a 25 degree angle to the ground. Assuming that the building forms a perfect 90 degree angle to the ground, how high will their ladder be able to reach?

- A) $50 \sin 25$
- B) $50 \cos 25$
- C) $\frac{\tan 25}{50}$
- D) $\frac{\sin 25}{50}$
- E) $\frac{50}{\cos 25}$

On problems like these, the first thing that you have to do is draw out the scenario as described as accurately as possible. (Small stick figures running from the flames are optional.)

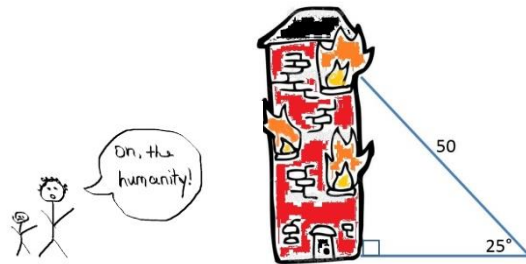

As you can see, the scenarios always somehow magically manage to create a right triangle. In this case, the ladder is the hypotenuse and we are trying to solve for the height at which the ladder will touch the building. The only truly hard part of this problem is figuring out if it is a sine, cosine, or tangent situation. How do you do that? By identifying the sides and angle involved. In this case, since we're using the 25° angle, the sides involved would be the opposite and hypotenuse. You return to SOHCAHTOA and see that those sides relate to sine. Now that you know that, this becomes a very straight forward problem, because you just set up the ratio like any other trig question:

$$\sin 25 = \frac{\text{height}}{50}$$

Since the question wants us to solve for the height, just multiply both sides by 50 and, voila, the answer is height = 50 sin 25, or answer choice A.

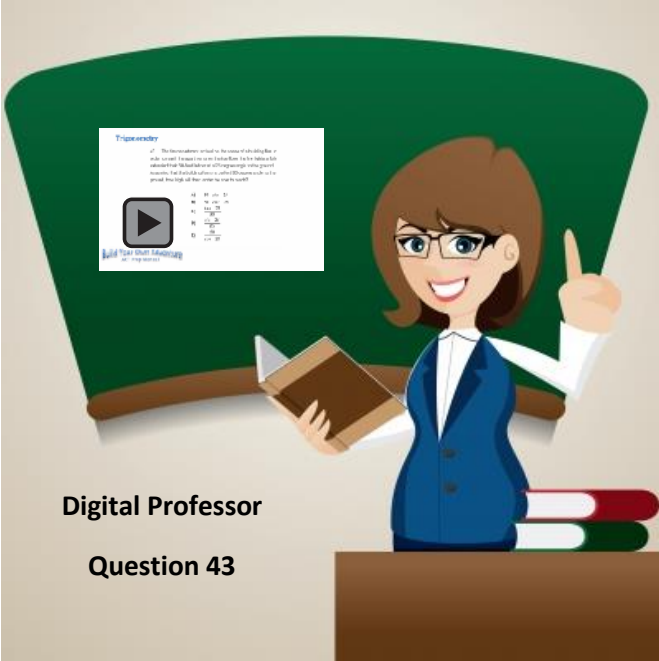

Graphing

Now that you are comfortable with basic trigonometry, you can take a look at the occasional questions that move beyond the realm of SOHCAHTOA. These advanced questions tend to revolve around graphing. Fortunately for you, graphing basic functions is super easy. Let's start at the beginning.

$$y = \sin x$$

Trig equations don't get any simpler than that. But what does it mean? Merely this:

There are two key vocab terms that the ACT test-writers will expect you to know. The first is amplitude (or how high on the y -axis does the graph go), and the other is period (or how long on the x -axis before the wave repeats). Amplitude is the easy part. See that number in front of \sin ? Oh, there isn't one? That's because the default number is 1, and conveniently enough, that means the amplitude is 1. What does that mean? That means that at its highest point, the graph goes up 1 unit, and at its lowest point, it goes down 1 unit. So let's mix it up a bit. What if the equation was $y = 2 \sin x$? You guessed it. The amplitude is now 2.

Period is a bit more annoying to deal with. The base period for all sine and cosine functions is 2π . Alas, you don't see that in the base equation, do you? The way you obtain this is by using the number in front of the x . (Since the equation $y = \sin x$ has nothing in front of the x , that is just the default 1.) You calculate period by taking 2π and dividing by that number. So in this scenario, the period is 2π because $\frac{2\pi}{1} = 2\pi$.

So let's get wild and crazy. What would the amplitude and period be for the following equation?

$$y = 4 \sin 2x$$

That looks tough, but all you have to do is look at the numbers involved. The amplitude is always the number in front of the trig term, in this case 4. The period is always 2π divided by the number in front of the x , in this case 2. Therefore the period is $\frac{2\pi}{2} = \pi$.

Easiest of all is the graphing part, because you will almost always just draw the same wave and then just change your labels. Let's take a look at how that works.

The basic shape of the sine wave doesn't change. It starts at the origin, goes up to the top of its amplitude, goes down to the bottom of its amplitude, and ends up back on the x -axis. So no matter what the specifics of the equation, you can always start by drawing that standard shape and then changing the labels. Let's start with the simplest equation first: $y = \sin x$. As we discussed above, the amplitude would be 1 and the period would be 2π . The graph below demonstrates how this would look:

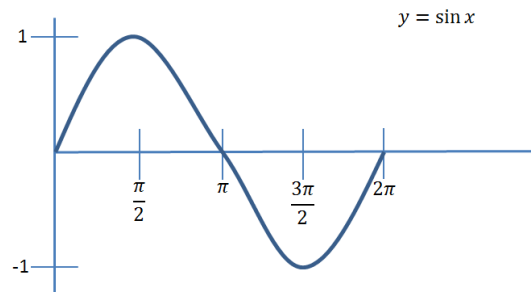

So let's start playing. What would the graph of $y = 2 \sin x$ look like?

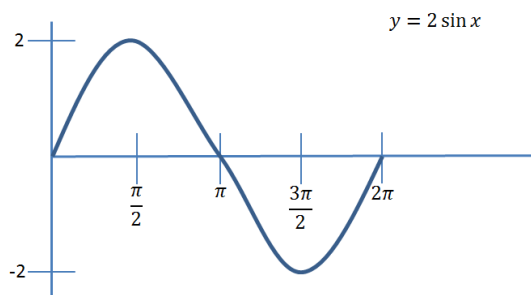

What about $y = 4 \sin 2x$?

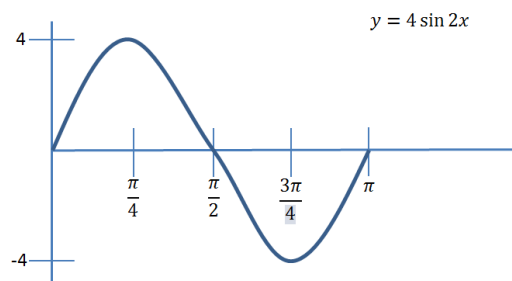

Yes, when drawn to scale the wave will get skinnier or fatter, etc., but who cares? It still means exactly the same thing. So the hardest part of any of these questions is knowing what amplitude and period mean, how you derive them based on the equation, and then how to label the axes.

Beyond these basics, there are a few ways they can make the graphing part harder. The first scenario involves making the sine term negative, as in $y = -\sin x$. Fortunately, there is only one major change: the curve starts by going down instead of up.

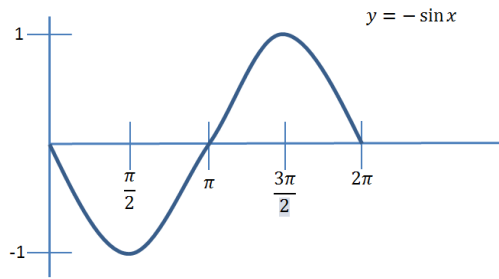

The only other thing they can do is shift the graph up or down. That happens when they have a number hanging off the end of the equation. Let's look at what would probably be the nastiest equation you would probably ever see on the ACT:

$$y = \sin \pi x + 1$$

As before, everything we have already talked about stays the same. The amplitude is 1; the period is $\frac{2\pi}{\pi} = 2$. Only the "+1" hanging off the end is different, and all that means is that the entire graph is shifted up by one. Here is what the graph would look like:

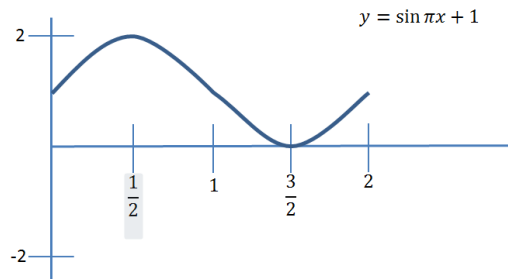

The reality is you will probably only see one, maybe two, of any trig graphing questions on the test, and when they show up they will be near the end. But they're not that bad, are they?



SOME FRIENDLY ADVICE

Even though everything here has focused on sine waves, the beautiful thing about this topic is that graphing sine and cosine waves is absolutely identical with one exception. Sine waves start at the origin; cosine waves start at the peak of their amplitude. Otherwise, all the rules, vocab, shifts, etc., are exactly the same. Here is an example:

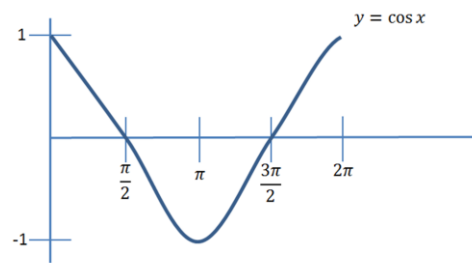

Circles (again)

We have been labeling them since kindergarten. Aristotle considered them the perfect shape. Angels wear them around their heads. Why did mathematicians have to make them so dang complicated?

Fortunately, they're really not too difficult to deal with once you see the pattern. Basic geometry questions about circles involving area or circumference will show up all over the test (and you can review this content in the Geometry chapter earlier in this book), but once you get to the hard questions at the end, the test writers ramp up the difficulty by asking you to identify the equation of a charted circle. So let's start with the simplest circle of all, shall we?

$$x^2 + y^2 = r^2$$

What does that mean? Let's get rid of the variables and talk about a real-life circle. (Well, it's not actually alive, but bear with me.) Let's say we have a circle centered at the origin with a radius of 3. It would look like this:

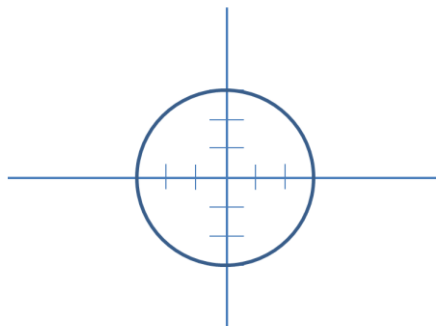

The equation for this circle would be $x^2 + y^2 = 3^2$, or $x^2 + y^2 = 9$. That's not too hard, right?

Unfortunately, not every circle is centered at the origin. What happens then? Let's take that same circle pictured above and plop it down so that its center is actually $(-2, 1)$. It would look like this:

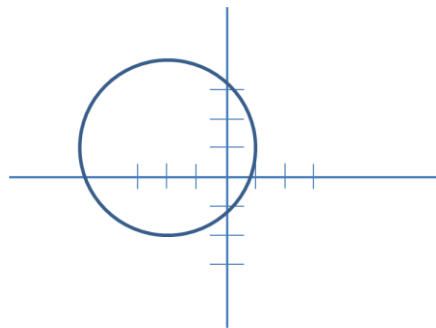

Obviously the formula would have to change since the circle moved, but the way it changes is the exact opposite of what you would expect. The new center goes next to the x and y WITH THE REVERSE SIGN. So in this case, the formula for the circle would be

$$(x + 2)^2 + (y - 1)^2 = 9$$

So all you have to remember is that the center of the circle goes inside the parentheses OPPOSITE of what they really are, and the equation is always equal to the radius squared. Let's consider another example.

$$(x - 3)^2 + (y + 3)^2 = 4$$

The center of this circle would be $(3, -3)$, and the radius would be 2. Based on this information, the graph of the circle would look like the image pictured to the right:

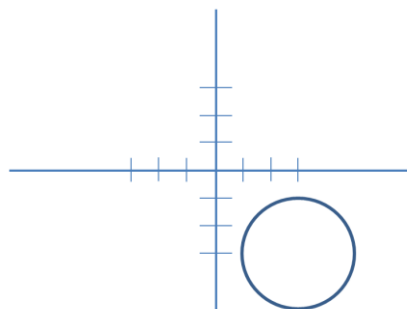

Misconception Alert

Test writers tend to try to catch students on simple pattern errors, so your job is to make sure that your equation ALWAYS has the following traits:

It is always equal to r^2

The x^2 and the y^2 are always being added together

The sign inside the parentheses in the equation is always the opposite of the actual sign for the center coordinate



Sometimes, just to really push the difficulty level, the test writers will describe the situation and ask you for the formula. If they give you the center and radius, it is very straightforward. The worst thing they will do, though, is give you that information indirectly instead of directly, like in this example:

46. A circle graphed in the rectangular coordinate plane is tangent to the y axis at 2 and has a diameter of 2. What equation would describe the circle?

- A) $(x - 1)^2 - (y - 2)^2 = 1$
- B) $(x - 1)^2 + (y - 2)^2 = 1$
- C) $(x + 1)^2 + (y + 2)^2 = 2$
- D) $(x + 1)^2 - (y + 2)^2 = 2$
- E) $(x - 1)^2 + (y + 2)^2 = 4$

The first step to a problem like this is actually creating the image described to you in such loving detail. To do that, you have to know what one key word means: tangent. In the last two sections we have been using that in its trigonometric sense as it relates to triangles. However, it also has a different meaning in regards to circles. Essentially, a line is tangent to a circle when it touches at only one point. Knowing that, you can construct the graph as follows:

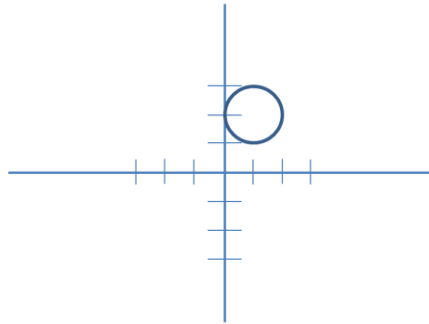

The drawing is helpful because it allows us to identify the center $(1, 2)$ more easily than we could have based on just the written description alone. As we are told that the diameter is 2, we know the radius is 1. That was all we needed! Now, we can fill in the appropriate numbers into the equation as $(x - 1)^2 + (y - 2)^2 = 1$, or answer choice B.

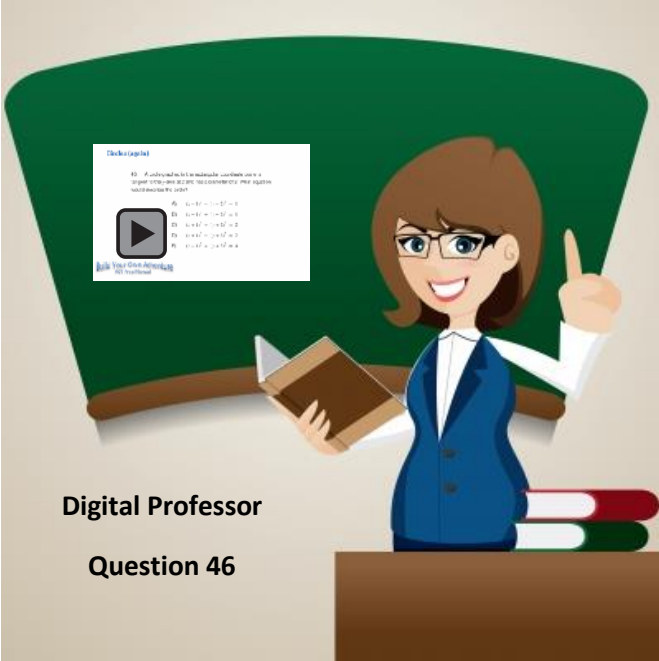

The image features a cartoon character of a female professor with brown hair and glasses, wearing a blue vest over a white shirt. She is standing behind a brown desk with a stack of books (red, white, and green) and pointing her right index finger upwards. Behind her is a large green chalkboard. A white rectangular box is overlaid on the chalkboard, containing a play button icon and text. The text in the box reads: "Dica da apostila", "46. A expressão 'Luz e sombra' encontra-se em um texto de caráter predominantemente narrativo. Assinale a opção correta.", and a list of four options: "A. Luz e sombra", "B. Luz e sombra", "C. Luz e sombra", and "D. Luz e sombra".

Digital Professor

Question 46

Logarithms

This section was almost eliminated not because logs are so hard, but rather because there are just so few questions about them on the ACT. However, you Type-A people out there who want to ace the math section might need it, so here it is. Logs are just another way to talk about exponents. The trick is to know what each part of the equation stands for. So let's look at an example:

$$2^3 = 8 \text{ is the same thing as } \log_2 8 = 3$$

That would be spoken as "log base 2 of 8 equals 3," in case you're curious. So all you have to do is remember where everything goes, right?

Yes and no. Some questions will be just that—a memory game to see if you are familiar with logs. Others will go further and test the rules of logs. Fortunately, these rules are identical to the rules of exponents:

$$x^2 \cdot x^3 = x^5$$

Multiplying? Add the exponents

$$\frac{m^7}{m^3} = m^4$$

Dividing? Subtract the exponents

$$(y^2)^4 = y^8$$

Raising to a power? Multiple the exponents

So let's see how this would play out in the land of logs. Let's start out with the easier questions first:

13. $\log_5 125 =$

- A) 1
- B) 3
- C) 5
- D) 25
- E) 125



SOME FRIENDLY ADVICE

Um, you have a calculator, right? So why are we even talking about solving this equation? Nearly every scientific calculator on the market will solve this question with a few keystrokes. If yours won't, you might want to consider retiring the old abacus and upgrading to a newer model.

This question follows the basic log set up discussed above. The 5 is the base that is being raised to an unknown power. The 125 is the outcome. So essentially, the question is really asking

$$5^? = 125$$

Well, since you put it that way, the easiest way to determine the answer is to use the answer choices. One of those five options has to be correct, so we can Plug In the Answer Choices (as discussed in more detail in this previous section) to find the answer quickly. One of the five options listed has to work; let's just raise 5 to each of those powers until we get the answer we want, right?

- A) $5^1 = 5$
- B) $5^3 = 125$
- C) $5^5 = 3125$
- D) $5^{25} = \text{ridiculous huge number}$
- E) $5^{125} = \text{you're kidding, right?}$

Thus, we know the answer must be B because it is the one that yields 125.

Imaginary Numbers

Despite the name, there really is such a thing as imaginary numbers and, yes, we all wonder why mathematicians felt the need to create them. The basic concept of imaginary numbers is to deal with that pesky question: what is the square root of -1 ? Anytime you multiply the same number times itself, whether it is positive or negative, you always get a positive outcome. For example,

$$5 \cdot 5 = 25 \quad \text{or} \quad (-4) \cdot (-4) = 16$$

So how could you possibly multiply the same number times itself and get a negative answer? You can't. Thus the need for i .

$$i = \sqrt{-1}$$

And you thought mathematicians weren't creative. Shame on you.

Even though this seems like it could get complicated—and it does, in real life—fortunately on the ACT imaginary number questions are actually just pattern questions, because something cool happens when you start going through the powers of i .

i^1	is the same thing as	$\sqrt{-1}$	which is equal to	i
i^2	is the same thing as	$i \cdot i,$ or $\sqrt{-1} \cdot \sqrt{-1}$	which is equal to	-1
i^3	is the same thing as	$i^2 \cdot i,$ or $(-1) \cdot i$	which is equal to	$-i$
i^4	is the same thing as	$i^2 \cdot i^2,$ or $(-1) \cdot (-1)$	which is equal to	1

But what happens with you get to i^5 ? That's just the same thing as $i^4 \cdot i$, right? Since $i^4 = 1$, that means that only i will be left.

i^5	is the same thing as	$i^4 \cdot i,$ or $1 \cdot i$	which is equal to	i
i^6	is the same thing as	$i^4 \cdot i^2,$ or $1 \cdot i^2$	which is equal to	-1
i^7	is the same thing as	$i^4 \cdot i^3,$ or $1 \cdot i^3$	which is equal to	$-i$
i^8	is the same thing as	$i^4 \cdot i^4$ or $1 \cdot 1$	which is equal to	1

If you continued this process, you would quickly see that the pattern repeats every four terms as you go.

i^1	is the same thing as	i^5	which is the same thing as	i^9
i^2	is the same thing as	i^6	which is the same thing as	i^{10}
i^3	is the same thing as	i^7	which is the same thing as	i^{11}
i^4	is the same thing as	i^8	which is the same thing as	i^{12}

That makes these questions very easy to do if you just remember the results of the first four powers of i .

Let's take a look at an example.

53. In the complex number system, where $i^2 = -1$, $\frac{i^8 - i^2}{i} \cdot \frac{i^3}{i^4 + 1} =$

- A) 1
- B) -1
- C) $\frac{i^9}{i^4 + 1}$
- D) $\frac{i^{11} - i^5}{i^5 + i}$
- E) $\frac{i^3}{i^4 + 1}$

This question looks intimidating until you realize it is just simple algebra. The only trick to it is substituting in the appropriate power of i to simplify. So let's do just that. Using what we know about how the values of i repeat, we can substitute in the corresponding value for each of these terms. Look at the original question:

$$\frac{i^8 - i^2}{i} \cdot \frac{i^3}{i^4 + 1}$$

There are lots of terms in there that we can replace, as shown here:

$$\frac{i^8 - i^2}{i} \cdot \frac{i^3}{i^4 + 1} =$$

This will give us a much easier equation to work with.

$$\frac{1 - (-1)}{i} \cdot \frac{-i}{1 + 1} = \frac{2}{i} \cdot \frac{-i}{2} = \frac{-2i}{2i} = -1$$

It's strange that so complicated an equation could simplify to something as easy as -1 , but it did. Much like most of the Advanced Topics in this section, you won't see imaginary numbers too much on the test, but when they do show up just remember the pattern and do some basic algebra.



The Nitty Gritty (Math edition)

So, you are staring at a blank ACT and need a plan. What do you do with the Math Test?

1. Expect to run out of time. While it isn't as tough to finish as some of the other sections, it is still rare for students to work every single question. Most people should be happy if they get to question 45.
2. Accuracy is key. Take your time and double check your work, especially on the first 10 questions. They are usually the easiest of the test, which ironically means that you are more likely to miss them due to careless mistakes.
3. Beware the end. The last 10 questions or so will be tough. If you get to them, **DO NOT** pick the easy, obvious answer. If the question takes you 15 seconds to do, you are wrong.
4. Learn the formulas. The ACT test writers will not provide the basic geometry formulas, so you need to come in with them in your head. Plan accordingly.
5. Plug in anytime you don't know anything. 'Nuff said.
6. Your calculator is only as smart as you are. Use it for number crunching and make sure you know how to take advantage of its various features, but don't expect it to solve the questions for you.
7. Write down your work. Don't do any more than one step in your head. It is too easy to make mistakes otherwise.

APPENDIX C:
IMPLEMENTATION OF DESIGN ELEMENTS

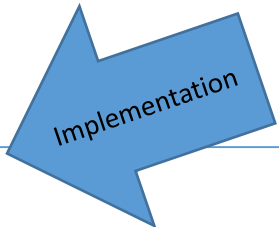

About the ACT

The ACT is an awesome test, and, no, I am not being paid to say that. While no test is perfect, this one comes darn close by balancing the knowledge that a typical high school student should have learned in high school with a reasonable testing scenario. In addition, it is something that you can improve by understanding the content focused upon and the way the test is written. It's hard to get better than that.

While some people may argue that standardized tests measure innate ability and thus cannot be improved through study, nothing could be further than the truth. There is no such thing as a test that you can't study for. In fact, your ACT score can definitely be improved, but not by memorizing content alone. It is very important to know HOW the test operates and to develop a customized strategy that takes advantage both of its design and your personal strengths. Here are some of the most important items that you need to know:

- **Test Structure.** The ACT is long—there's no denying that. The actual breakdown of sections is as follows:

Test	Questions	Time Allotted
English	75 questions	45 minutes
Math	60 questions	60 minutes
Reading	40 questions	35 minutes
Science	40 questions	35 minutes
Writing (optional)	1 question	30 minutes

Unlike other tests, the ACT is nice in that it clumps content into one section, and doesn't force you to constantly jump back and forth between the same subjects repeatedly throughout the test. That means that once you complete the math section, you're done with math. Once you complete reading, you're done with reading. This mirrors the typical high school day, so our brains like it. It's good to keep your brain happy.

- **Timing.** When most people look at the actual breakdown of the test, their first response is something to the effect, "How can they flipping expect me to answer 75 questions in just 45 minutes?!?" The answer: They don't. You will run out of time on this test. If you don't know that, the first time the proctor announces you have five minutes left and you're only halfway through a section, you will freak out. However, this is NOT a test that requires you to answer every single question perfectly to get a great score. Instead, accuracy matters much more than quantity. While, of course, you want to put down as many answers as you can to get the highest possible score, you want to make sure that all the answers you put down are correct. It's not a

Familiarity is the only strategy actually recommended by the test writers themselves, as well as resoundingly supported in research to improve student scores. Therefore the very first item in the manual itself is an overview of the ACT and the key factors that impact student performance.

48. What is the average of $2x$, $\frac{3}{2}x + 4$, $2x - 7$, and $\frac{5}{2}x - 1$?

A) $8x - 4$
 B) $\frac{12x-4}{2}$
 C) $\frac{6x-2}{4}$
 D) $16x^2 - 28$
 E) $2x - 1$

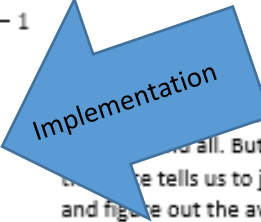

Implementation

... annoying, what with the
 ... all. But the variables all over
 ... tells us to just make up a number
 and figure out the average. So let's make
 up something for x . How about $x = 2$.

SOME FRIENDLY ADVICE

One of the most beautiful things about plugging in
 is that you are in **COMPLETE CONTROL** of what
 numbers to use. In this example, since there are
 fractions, it is a great idea to use an even number
 because the math will work out very easy. So the
 moral of the story is if you can use any number, let's
 not use π . And if you pick a number and the math
 starts to get messy, just change it.
 I won't tell if you won't.

We can plug in that 2 everywhere we
 see an x , so our four terms become

$$2x = 2(2) = 4$$

$$\frac{3}{2}x + 4 = \frac{3}{2}(2) + 4 = 3 + 4 = 7$$

$$2x - 7 = 2(2) - 7 = 4 - 7 = -3$$

$$\frac{5}{2}x - 1 = \frac{5}{2}(2) - 1 = 5 - 1 = 4$$

It's much easier to find the average of 4, 7, -3, and 4 than it is to find the average of four
 algebraic expressions, right? We just add up the values [$4 + 7 + (-3) + 4 = 12$] and then divide by
 how many terms we have (4). So the answer is $\frac{12}{4} = 3$. (Click here if you want a more in-depth review of
 how to find average.) With that, we just go through the answer choices until 3 spits out:

Test-wiseness refers to the student's ability to understand and take advantage of elements of test construction to his benefit. Thus, "Some Friendly Advice" boxes are placed throughout the text to highlight these items and indicate how students should make use of them.

Vygotsky's Zones of Proximal Development

Advanced Topics

Trigonometry

Yikes, that sounds scary, doesn't it? Fortunately for us all, it is not nearly as bad as it seems. These questions all revolve around one specific acronym that sounds like it should appear in an American History textbook instead of a Math classroom:

SOHCAHTOA

No, that is not the name of the Native American who guided Lewis and Clark on their miraculous westward journey. This is instead an awesome acronym that allows you to solve many trig questions correctly with minimal effort.

So what does it mean? Glad you asked.

SOHCAHTOA provides a simple way of remembering the ratio of sides for the three basic trig functions: sine, cosine, and tangent. Each letter stands for a specific word:

<i>S-O-H</i> tells you that	$\text{sine} = \frac{\text{Opposite}}{\text{Hypotenuse}}$
<i>C-A-H</i> tells you that	$\text{cosine} = \frac{\text{Adjacent}}{\text{Hypotenuse}}$
<i>T-O-A</i> tells you that	$\text{tangent} = \frac{\text{Opposite}}{\text{Adjacent}}$

Let's consider a standard right triangle, pictured below, with sides of 3-4-5. We'll identify one of the non-right angles inside the triangle as x . Applying what we know about SOHCAHTOA, identify the exact values of sine, cosine, and tangent for this triangle:

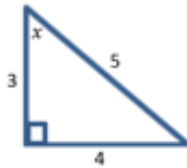

$$\sin x = \frac{\text{Opposite}}{\text{Hypotenuse}} = \frac{4}{5} \qquad \cos x = \frac{\text{Adjacent}}{\text{Hypotenuse}} = \frac{3}{5}$$
$$\tan x = \frac{\text{Opposite}}{\text{Adjacent}} = \frac{4}{3}$$

There's nothing else to it. So let's look at another example.

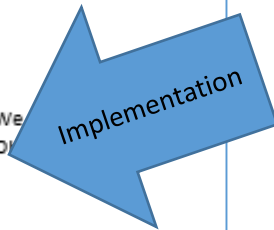

Vygotsky indicated that students must be challenged appropriately to stimulate learning: make the content too easy, and they will be bored and stifled; make it too hard, and they will be frustrated and unresponsive. This ideal learning space is his Zone of Proximal Development. In a manual designed for various personas, then, a scaffolded approach had to start with easy material for the weaker student, but progress to harder material in a non-threatening way for the more advanced.

Millman's Time-Using Strategy

Math Introduction

Ah, math. You either love it or you hate it, right? The majority of the questions revolve around algebra (about 50 percent of the section) and geometry (about 40 percent of the section), but some of the content comes from material you learned in elementary school so we need to dust off the cobwebs a bit, too. There will also be a handful of more advanced questions, such as trigonometry, imaginary numbers, etc., but only a few and usually near the end, so depending on your speed you might not even see them.

Here are the basics you need to know about this section:

- It is the second multiple choice section. This means that you will still be relatively fresh when you hit it. However, it is also 60 minutes long, and since you hit it straight after the first section with no break, you might be feeling some mental fatigue. As Taylor Swift would say, shake, shake, shake it off....
- Timing is tough. The test designers don't intend for you to finish, and most people won't. Don't let any one question hold you up.
- Pacing. The timing issue means that you should have a plan about how many questions you should answer to get the score you want. Use the chart below as a guide:

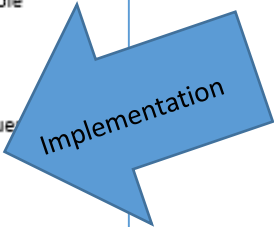

Score	Correct Answers	Score	Correct Answers	Score	Correct Answers
36	60	27	45	18	26
33	55	24	38	15	15
30	51	21	33	12	8

Unless you're perfect, you should plan on doing a few more questions than listed above. Most people should try to get to through the first 45 questions before they start using their Magic Letter. Remember: No blanks allowed!

- Calculators are allowed. This is the only place on the test where you are allowed to use a calculator, so make sure that you have it fully charged or bring an extra battery, just in case. You should also do all of your practice in this manual with the calculator you plan to use on the day of the test. You can waste a lot of time just trying to figure out how to calculate something otherwise.

Millman's Time-Using Strategy, which is actually an element of Test-wiseness, calls for students to have a clear understanding of how something as simple as timing can impact performance. They should also have a solid strategy in place for how many questions to answer in the given time. Thus, the Math Introduction provides specific guidance on this front.

Millman's Error-Avoidance Strategy

- No formulas. This is one way that the ACT demonstrates that it is a knowledge test—the test writers expect you to come to the test with certain formulas memorized. The formulas you need to know are as follows:

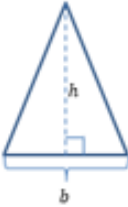

$$A = \frac{1}{2}bh$$

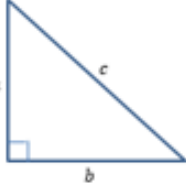

$$a^2 + b^2 = c^2$$



$$A = lw$$

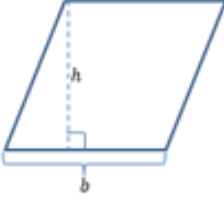

$$A = bh$$



$$A = \pi r^2$$

$$C = 2\pi r$$

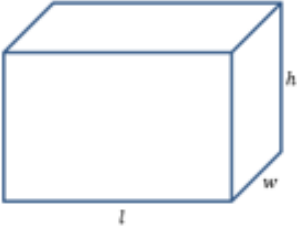

$$V = lwh$$

$$SA = 2lw + 2lh + 2wh$$

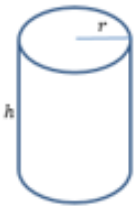

$$V = \pi r^2 h$$

$$SA = 2\pi r^2 + 2\pi rh$$

- Order of Difficulty. The questions on the math section get progressively harder, so use the question placement as a guide. The first 20 questions should be pretty straightforward; the last 20 questions should be pretty tough. This yields two counterintuitive strategies:

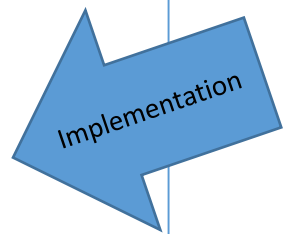

Millman's research also indicated that the student should focus on the fact that most standardized tests are error-driven, meaning that students should focus on finding wrong answers rather than right ones. Thus it is useful for students to know which questions are more likely to be problematic, as indicated here in the Math Introduction.

Mayer's Signalling Principle

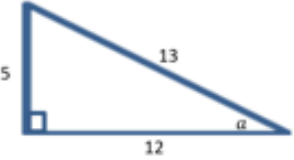

$\sin \alpha = \frac{5}{13}$ $\cos \alpha = \frac{12}{13}$ $\tan \alpha = \frac{5}{12}$



Misconception Alert

Many students get confused about which side is the adjacent and which side is the hypotenuse when the angle is in between them both. Just remember—the hypotenuse is ALWAYS the longest side of the right triangle. The adjacent, therefore, must ALWAYS be one of the legs.



With the basics established, it's not uncommon at all for the test writers to extend the basics into a few tougher scenarios. For one, you can be given one of the trig functions and then asked to solve for a side of the triangle. For example, consider this problem:

27. For $\triangle ABC$, shown below, $\sin \alpha = \frac{3}{5}$. What is the length of AB ?

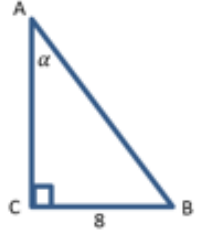

A) 3

B) 5

C) 10.5

D) 13.3

E) 15

We can still apply SOHCAHTOA to this situation. Looking at the triangle as pictured, we can determine that $\sin \alpha = \frac{8}{AB}$. But the question stated that $\sin \alpha = \frac{3}{5}$. While at first this seems to be a contradiction,

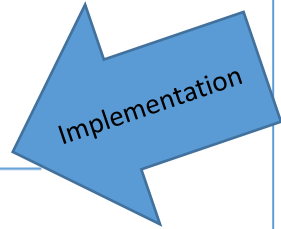

The Signalling Principle calls for key information to be highlighted not just in text but in multimedia shapes. Thus the Misconception Alerts throughout the manual visually call attention to common errors that students need to avoid.

APPENDIX D:
CURRICULUM FLOW OF FULL MANUAL

These models represent the full scope of material that will be covered in the “Build Your Own Adventure” manual.

English Curriculum Flow

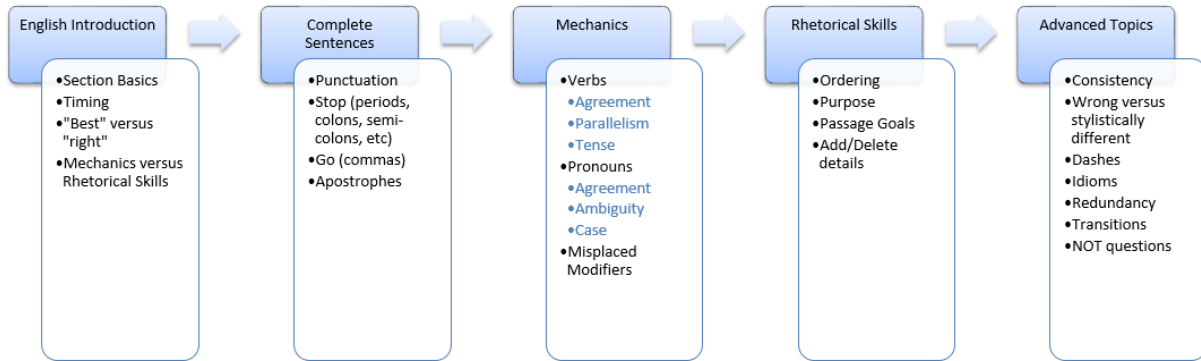

Math Curriculum Flow

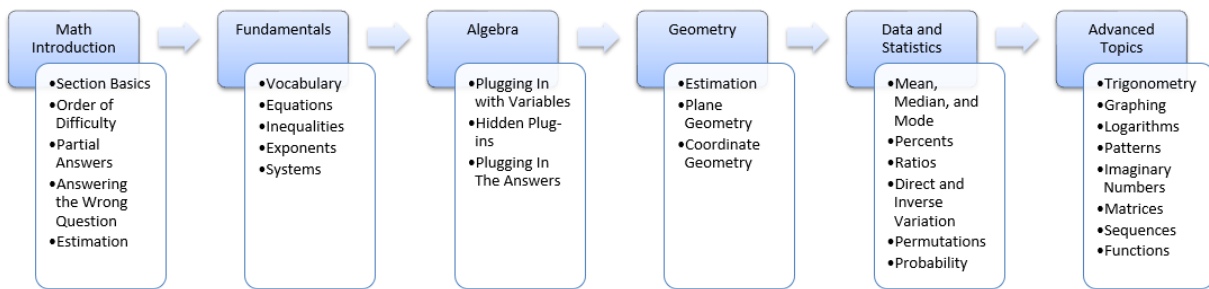

Reading Curriculum Flow

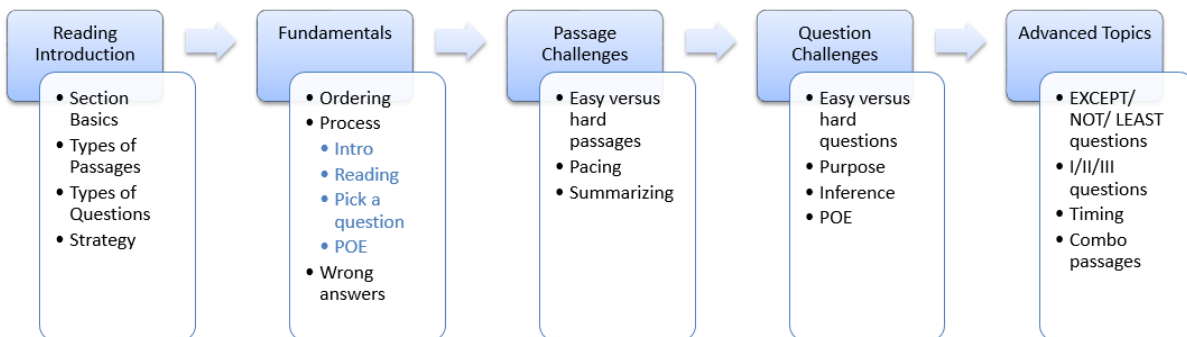

Science Curriculum Flow

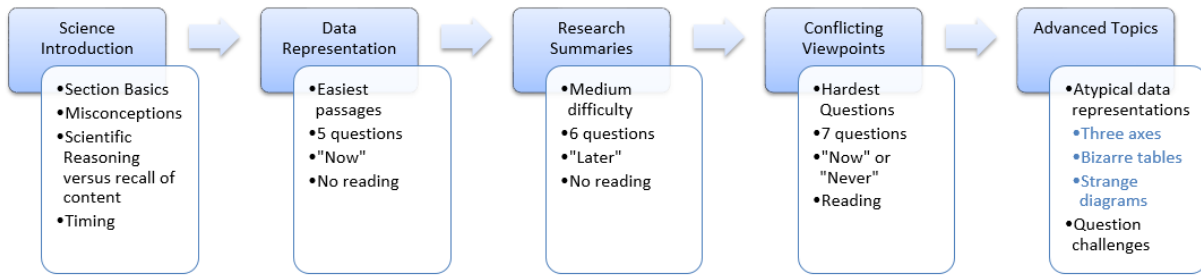

Writing Curriculum Flow

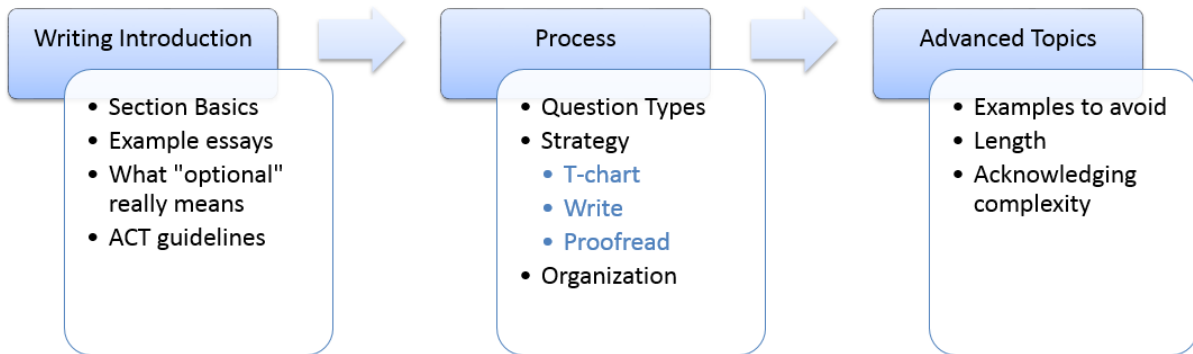

REFERENCES

- Ackerman, P. L., & Kanfer, R. (2009). Test Length and Cognitive Fatigue: An Empirical Examination of Effects on Performance and Test-Taker Reactions. *Journal of Experimental Psychology: Applied*, 15(2), 163-181.
- ACT. (2014). *Preparing for the ACT College Readiness Assessment*. Iowa City, IA: ACT Publishing.
- Anastasi, A. (1981, October). Coaching, Test Sophistication, and Developed Abilities. *American Psychologist*, 36(10), 1086-1093.
- Anderson, L. W., & Krathwohl, D. R. (eds.). (2001). *A Taxonomy for Learning, Teaching, and Assessing: A Revision of Bloom's Taxonomy of Educational Objectives*. New York, NY: Longman.
- Bassett, P. F. (2004, Fall). Accountability and Independence for Schools: Towards a Higher Standard. *Independent School Magazine*. Retrieved from <http://www.nais.org/Magazines-Newsletters/ISMagazine/Pages/Accountability-and-Independence-for-Schools.aspx>
- Becker, B. J. (1990, Fall). Coaching for the Scholastic Aptitude Test: Further Synthesis and Appraisal. *Review of Educational Research*, 60(3), 373-417.
- Becker, B. J., & Hedges, L. V. (1984). Meta-Analysis of Cognitive Gender Differences: A Comment on an Analysis by Rosenthal and Rubin. *Journal of Educational Psychology*, 76(4), 583-587.

- Behrendt, A., Eisenach, J., & Johnson, W. R. (1986). Selectivity bias and the determinants of SAT scores. *Economics of Education Review*, 5(4), 363-371.
- Berger, S. J. (2012). The Rise and Demise of the SAT. *American Educational History Journal*, 39(1), 165-180.
- Bernhardt, V. L. (2004). *Data Analysis for Continuous School Improvement*. Larchmont, NY: Eye on Education.
- Birnbaum, R., Glickman, J., Robbins, B., & Tollin, M. (Producers) & Robbins, B. (Director). (2004). *The Perfect Score* [Motion picture]. United States: Paramount Pictures.
- Bolman, L. G., & Deal, T. E. (2008). *Reframing organizations: artistry, choice, and leadership*. San Francisco, CA: Jossey-Bass.
- Bond, L. (2008). Teaching to the Test: Coaching or Corruption. *The New Educator*, 4(3), 216–223.
- Borich, G. D. (2011). *Effective Teaching Methods: Research-Based Practice*. Boston, MA: Pearson.
- Brassell, D. (2009). *75+ Reading Strategies: Boost Achievement and Build a Life-Long Love of Reading*. New York, NY: Scholastic.
- Brunner, M., Artelt, C., Krauss, S., & Baumert, J. (2007). Coaching for the PISA test. *Learning and Instruction*, 17, 111-122.

- Canales, R. (2014, January/February). Weaving straw into gold: Managing organizational tensions between standardization and flexibility in microfinance. *Organizational Science*, 25(1), 1-28.
- Churches, A. (2011). Digital Learning. *Teacher Librarian*, 39(2), 34-35.
- Clark, R. C., & Mayer, R. E. (2008, October). Learning by Viewing versus Learning by Doing: Evidence-based Guidelines for Principled Learning Environments. *Performance Improvement*, 47(9), 5-13.
- Cocking, R. R., Mestre, J. P., & Brown, A. L. (2000). New Developments in the Science of Learning: Using Research to Help Students Learn Science and Mathematics. *Journal of Applied Developmental Psychology*, 21(1), 1-11.
- Cole, N. (1982). The implications of coaching for ability testing. In A. K. Wigdor, & W. R. Garner (Eds.), *Ability Testing: Uses, Consequences, and Controversies Volume 2* (pp 389-414). Washington, DC: National Academy Press.
- College Board. (2014). *Be Prepared*. Retrieved from <http://sat.collegeboard.org/practice/sat-practice-questions>
- College Board. (2014). *What's on the PSAT/NMSQT*. Retrieved from <https://www.collegeboard.org/psat-nmsqt/preparation/whats-on-the-test>
- College Board. (n.d.). *Effects of Coaching on SAT Scores*. Retrieved from http://www.collegeboard.com/prod_downloads/highered/ra/sat/coaching.pdf

College Compass. (2012, January 6). *What is the 2011 PSAT cutoff Score for National Merit Scholarships?* Retrieved from <http://collegeadmissions.testmasters.com/what-is-the-2011-psat-cutoff-score-for-national-merit-scholarships/>

Creswell, J. W. (2007). *Qualitative Inquiry & Research Design: Choosing Among Five Approaches*. Thousand Oaks, CA: Sage.

Dandridge, T. C., Mitroff, I., & Joyce, W. F. (1980). Organizational symbolism: A Topic to expand organizational analysis. *Academy of Management Review*, 5(1), 77-82.

Davis, K., Gamble, J., Humphries, B., Mitchell, L., & Pendergrass, E. (2013). A Correlational Study of Breastfed 11th Graders and PSAT Scores. *Sandra Blair Community Health Program*. Retrieved from <http://www.lagrange.edu/resources/pdf/citations/nursing/A%20Correlational%20Study.pdf>

DerSimonian, R., & Laird, N. M. (1983, February). Evaluating the effect of coaching on SAT scores: A meta-analysis. *Harvard Educational Review*, 53(1), 1-15.

DeSilver, D. (2014, January 7). 5 facts about economic inequality. *Pew Research Center*. Retrieved from <http://www.pewresearch.org/fact-tank/2014/01/07/5-facts-about-economic-inequality/>

Desimone, L. M. (2013, August). Teacher and Administrator Responses to Standards-Based Reform. *Teachers College Record*, 115, 1-53.

- Education Week. (2011, September 11). *No Child Left Behind*. Retrieved from <http://www.edweek.org/ew/issues/no-child-left-behind/>
- Elpus, K. (2013). Is It the Music or Is It Selection Bias? A Nationwide Analysis of Music and Non-Music Students' SAT Scores. *Journal of Research In Music Education*, 61(2), 175-194.
- Fiorella, L., & Mayer, R. E. (2014). Role of expectations and explanations in learning by teaching. *Contemporary Educational Psychology*, 39, 75-85.
- The First Academy. (2013). *About TFA: Mission and Vision*. Retrieved from http://www.thefirstacademy.org/about_tfa/mission_and_vision
- The First Academy. (2014). *Tuition and Fees at the First Academy*. Retrieved from <http://www.thefirstacademy.org/admissions/tuition-fees/>
- Fitzpatrick, J., Christie, C., & Mark, M. M. (2009). *Evaluation in Action: Interviews with Expert Evaluators*. Los Angeles, CA: Sage.
- Fitzpatrick, J. L., Sanders, J. R., & Worthen, B. R. (2011). *Program Evaluation: Alternative Approaches and Practical Guidelines*. Boston, MA: Pearson.
- Freedle, R. (2003, Spring). Correcting the SAT's ethnic and social-class bias: A method for reestimating SAT scores. *Harvard Educational Review*, 73(1), 1-43.

- Galla, B. M., & Wood, J. J. (2012). Emotional self-efficacy moderates anxiety-related impairments in math performance in elementary school-age youth. *Personality and Individual Differences, 52*, 118-122.
- Gardner, E. (1982). Some aspects of the use and misuse of standardized aptitude and achievement tests. In A. K. Wigdor, & W. R. Garner (Eds.), *Ability Testing: Uses, Consequences, and Controversies Volume 2* (pp 315-332). Washington, DC: National Academy Press.
- Garrigues, G. L. (1994, Spring). National Merit Scholarships: A Major Dash of Jim Crow. *The Journal of Blacks in Higher Education, 3*, 60-64.
- Goodwin, L. (2013, June 21). As court prepares affirmative-action decision, softer standards for men go unnoticed. *Yahoo News*. Retrieved from <http://news.yahoo.com/blogs/ticket/court-prepares-affirmative-action-decision-softer-standards-men-182205509.html>
- Grabmeier, J. (2006, August 7). SAT Test Prep Tools Give Advantage to Students from Wealthier Families. *Research Communications at The Ohio State University*. Retrieved from <http://researchnews.osu.edu/archive/satprep.htm>
- Hannon, B. (2015). Hispanics' SAT Scores: The Influences of Level of Parental Education, Performance-Avoidance Goals, and Knowledge about Learning. *Hispanic Journal of Behavioral Sciences, 37*(2), 204-222.

Harrison, M. I. (2005). *Diagnosing Organizations: Methods, Models, and Processes*. Thousand Oaks, CA: Sage.

Hauptman, H., & Cohen, A. (2011). The synergetic effect of learning styles on the interaction between virtual environments and the enhancement of spatial thinking. *Computers & Education, 57*, 2106-2117.

HER Editorial Board. (2008, August 29). Bias in the SAT? Continuing the Debate. *Harvard Educational Review, 80*(3), 391-393.

Hickman, G. R. (ed.). (2010). *Leading Organizations: Perspectives for a New Era*. Los Angeles, CA: Sage.

Holt, L. C., & Kysilka, M. (2006). *Instructional Patterns: Strategies for Maximizing Student Learning*. Thousand Oaks, CA: Sage.

Iosphere. (2014, May 6). *Cartoon Cute Teacher Teaching At Blackboard Stock Photo*. Retrieved from FreeDigitalPhotos.net

Issa, N., Schuller, M., Santacaterina, S., Shapiro, M., Wang, E., Mayer, R. E., & DaRosa, D. A. (2011, August). Applying multimedia design principles enhances learning in medical education. *Medical Education, 45*(8), 818-826.

Kim, R., & Becker, B. J. (2010). The Degree of Dependence between Multiple-Treatment Effect Sizes. *Multivariate Behavioral Research, 45*(2), 213-238.

- Kubiszyn, T., & Borich, G. D. (2013). *Educational Testing & Measurement: Classroom Application and Practice*. Hoboken, NJ: John Wiley & Sons.
- Kulik, J. A., Bangert-Drowns, R. L., & Kulik, C. C. (1984). Effectiveness of Coaching for Aptitude Tests. *Psychological Bulletin*, 95(2), 179-188.
- Landsberg, M. (2008, December 26). Test prep book is SAT-ire. *Los Angeles Times*. Retrieved from <http://articles.latimes.com/2008/dec/26/local/me-sat26>
- Leonard, D. K., & Jiang, J. (1999). Gender Bias and the College Predictions of the SATs: A Cry of Despair. *Research in Higher Education*, 40(4), 375-407.
- Lewin, T. (2004, February 4). Film Makes SAT Villain, And Students Can Relate. *New York Times*. Retrieved from <http://www.nytimes.com/2004/02/04/nyregion/film-makes-sat-villain-and-students-can-relate.html>
- Lyon, L., Nadershahi, N., Nattestad, A., Kachalia, P. & Hammer, D. (2014, August). A curricular reform viewed through Bolman and Deal's organizational frames. *Journal of the Scholarship of Teaching and Learning*, 14(3), 16-33.
- Marchant, G. J., & Paulson, S. E. (2005, January 15). The Relationship of High School Graduation Exams to Graduation Rates and SAT Scores. *Education Policy Analysis Archives*, 13(6), 1-17.
- Marshall, B. (2008, December). The end of testing and future possibilities: An examination of the demise of Sats in England and possible alternative assessments. *English Teaching: Practice and Critique*, 7(3), 65-73.

- Mason, K. C. (2015, January 20). Obama: Community college should be “as free and universal in America as high school.” *PBS Newshour*. Retrieved from <http://www.pbs.org/newshour/rundown/community-college-tuition-top-theme-state-union-speech/>
- Mayer, R. E. (2008, November). Applying the Science of Learning: Evidence-Based Principles for the Design of Multimedia Instruction. *American Psychologist*, 63(8), 760-769.
- Mayer, R. E. (2009). *Multimedia Learning*. New York, NY: Cambridge University Press.
- Mayer, R. E. (2011). *Applying the Science of Learning*. Boston, MA: Pearson.
- Mayer, R. E. (2013). Research and Design Watch [Review of the article *Emotional design in multimedia learning* by E. R. Um, J. L. Plass, E. O. Hayward, and B. D. Homer]. *Informational Design Journal*, 20(2), 179.
- Mayer, R. E. (2014). Incorporating motivation into multimedia learning. *Learning and Instruction*, 29, 171-173.
- Mayer, R. E., & Estrella, G. (2014). Benefits of emotional design in multimedia instruction. *Learning and Instruction*, 33, 12-18.
- McLaren, B. M., DeLeeuw, K. E., & Mayer, R. E. (2011). A politeness effect in learning with web-based intelligent tutors. *International Journal of Human-Computer Studies*, 69, 70-79.

- McLaren, B. M., DeLeeuw, K. E., & Mayer, R. E. (2011). Polite web-based intelligent tutors: Can they improve learning in classrooms? *Computers & Education, 56*, 574-584.
- Messick, S., & Jungeblut, A. (1981). Time and Method in Coaching for the SAT. *Psychological Bulletin, 89*(2), 191-216.
- Millman, J., Bishop, C. H., & Ebel, R. (1965). An Analysis of Test-wiseness. *Educational and Psychological Measurement, 25*(3), 707-726.
- National Merit Scholarship Corporation. (2013). *NMSC Mission Statement*. Retrieved from <http://www.nationalmerit.org/mission.php>
- Nordquist, J., & Laing, A. (2015). Designing spaces for the networked learning landscape. *Medical Teacher, 37*, 337-343.
- O'Loughlin, K. (2011). The Interpretation and Use of Proficiency Test Scores in University Selection: How Valid and Ethical Are They? *Language Assessment Quarterly, 8*, 146-160.
- Owens, R. G., & Valesky, T. C. (2011). *Organizational behavior in education: leadership and school reform*. Boston, MA: Pearson.
- Palin, R. J. (2001, Spring). PSAT and AP Success. *OAH Magazine of History, 15*(3), 55-56.
- Plass, J. L., Heidig, S., Hayward, E. O., Homer, B. D., & Um, E. (2014). Emotional design in multimedia learning: Effects of shape and color on affect and learning. *Learning and Instruction, 29*, 128-140.

- Princeton Review. (2009). *Manual for the ACT Version 8.0*. New York, NY: Princeton Review Publishing.
- Reynolds, A. J., Oberman, G. L., & Perlman, C. (1988). An Analysis of a PSAT Coaching Program for Urban Gifted Students. *Journal of Educational Research*, 81(3), 155-164.
- Rhone, A. E. (2006, Summer). Preparing Minority Students for High-Stakes Tests: Who Are We Cheating? *Childhood Education*, 82(4), 233-235.
- Ryan, K. E., Ryan, A. M., Arbuthnot, K., & Samuels, M. (2007, January/February). Students' motivation for standardized math exams. *Educational Researcher*, 36(1), 5-13.
- Sackett, P. R., Borneman, M. J., & Connelly, B. S. (2008, May-June). High-Stakes Testing in Higher Education and Employment: Appraising the Evidence for Validity and Fairness. *American Psychologist*, 63(4), 215-227.
- Schunk, D. H. (1995). Self-efficacy, motivation, and performance. *Journal of Applied Sport Psychology*, 7(2), 112-137.
- Sheehan, K., & Gray, M. (1992, January). Sex Bias in the SAT and DTMS. *Journal Of General Psychology*, 119(1), 5-14.
- Sherwood, R. D., Kinzer, C. K., Hasselbring, T. S., & Bransford, J. D. (1987). Macro-contexts for Learning: Initial Findings and Issues. *Applied Cognitive Psychology*, 1, 93-108.

- Skager, R. (1982). On the use and importance of tests of ability in admission to postsecondary education. In A. K. Wigdor, & W. R. Garner (Eds.), *Ability Testing: Uses, Consequences, and Controversies Volume 2* (pp 286-314). Washington, DC: National Academy Press.
- Smart Survey. (2014). *Student Course Evaluation*. Retrieved from <http://www.smartsurvey.co.uk/sample-surveys/education-surveys/>
- Steele, C. M. (2011). *Whistling Vivaldi: How Stereotypes Affect Us and What We Do*. New York, NY: W.W. Norton & Co.
- Stufflebeam, D. L. (2001). *Evaluation Models*. San Francisco, CA: Jossey-Bass.
- Sung, E., & Mayer, R. E. (2012). When graphics improve liking but not learning from online lessons. *Computers in Human Behavior*, 28, 1618-1625.
- Um, E. R., Plass, J. L., Hayward, E. O., & Homer, B. D. (2012). Emotional design in multimedia learning. *Journal of Educational Psychology*, 104(2), 485-498.
- Urhahne, D., Chao, S, Florineth, M. L., Luttenberger, S., & Paechter, M. (2010). Academic self-concept, learning motivation, and test anxiety of the underestimated student. *British Journal of Educational Psychology*, 81, 161-177.
- US Census Bureau. (2014, July 8). *State & County QuickFacts Orlando (city), Florida*. Retrieved from <http://quickfacts.census.gov/qfd/states/12/1253000.html>

- Vaughn, E. S., III (2010, March 31). Reform in an Urban School District: The Role of PSAT Results in Promoting Advanced Placement Course-Taking. *Education and Urban Society*, 42(4), 394-406.
- Vernon, P. E. (1954). Symposium on the effects of coaching and practice in intelligence tests: Conclusions. *British Journal of Educational Psychology*, 24(2), 57-63.
- Vygotsky, L. (1997). Interaction between learning and development. In M. Gauvain & M. Cole (Eds.), *Readings on the Development of Children* (pp. 29-35). New York, NY: W.H. Freeman & Company.
- Wang, N., Johnson, W. L., Mayer, R. E., Rizzo, P., Shaw, E., & Collins, H. (2008). The politeness effect: Pedagogical agents and learning outcomes. *International Journal of Human-Computer Studies*, 66, 98-112.
- Wigdor, A. K., & Garner, W. R. (1982). Admissions Testing in Higher Education. In A. K. Wigdor, & W. R. Garner (Eds.), *Ability Testing: Uses, Consequences, and Controversies Volume 1* (pp 184-203). Washington, DC: National Academy Press.
- Wiggins, G., & McTighe, J. (2005). *Understanding by Design*. Upper Saddle River, NJ: Pearson.
- Will the Changes in the PSAT Affect Black Students' Ability to Win National Merit Scholarships? (1996, Winter). *The Journal of Blacks in Higher Education*, 14, 62-63.
- Wronkovich, M., & Hess, C. A. (1990). College Board Exams: The Effectiveness of Test Preparation for the PSAT. *American Secondary Education*, 18(3), 17-21.