Electronic Theses and Dissertations, 2004-2019

2013

Relating Climate Change To The Nesting Phenology And Nest Environment Of Marine Turtles

Monette Schwoerer
University of Central Florida



Part of the [Biology Commons](#)

Find similar works at: <https://stars.library.ucf.edu/etd>

University of Central Florida Libraries <http://library.ucf.edu>

This Masters Thesis (Open Access) is brought to you for free and open access by STARS. It has been accepted for inclusion in Electronic Theses and Dissertations, 2004-2019 by an authorized administrator of STARS. For more information, please contact STARS@ucf.edu.

STARS Citation

Schwoerer, Monette, "Relating Climate Change To The Nesting Phenology And Nest Environment Of Marine Turtles" (2013). *Electronic Theses and Dissertations, 2004-2019*. 2785.

<https://stars.library.ucf.edu/etd/2785>



University of
Central
Florida

Showcase of Text, Archives, Research & Scholarship

STARS

RELATING CLIMATE CHANGE TO THE NESTING PHENOLOGY AND
NEST ENVIRONMENT OF MARINE TURTLES

by

MONETTE VIRGINIA SCHWOERER
B.S. Palm Beach Atlantic University, 2005

A thesis submitted in partial fulfillment of the requirements
for the degree of Master of Science
in the Department of Biology
in the College of Science
at the University of Central Florida
Orlando, Florida

Fall Term
2013

Major Professor: Betsy Von Holle

ABSTRACT

Ectotherms (including marine turtles) being especially sensitive to climate, are at risk to the accelerated rate of human-driven climate change. This study addresses two concerns associated with marine turtles and climate change – the relationship between the timing of marine turtle nesting and sea surface temperature; and the concern over the feminization of marine turtle populations due to rising sand temperatures. Previous studies of loggerhead sea turtles (*Caretta caretta*) and green sea turtles (*Chelonia mydas*) have documented the relationship between sea surface temperatures and nesting phenology. Earlier nesting behaviors in both species have been associated with warmer sea surface temperatures. Also, sex determination for marine turtles is temperature-dependent. Due to current sand temperatures, it is estimated that loggerhead (*Caretta caretta*) nests along the Atlantic coast of Florida already produce over 89% female hatchlings. Using shade to reduce nest temperature and increase the proportion of male hatchlings is one option for mitigating the impacts of climate change on marine turtle sex ratios. In this study, a 21-year (1988-2008) dataset of hawksbill sea turtle (*Eretmochelys imbricata*) nesting at Buck Island Reef National Monument, St. Croix, U. S. Virgin Islands was analyzed in a similar manner to previous studies. It was found that warmer sea surface temperatures were associated with longer nesting seasons and later median nesting dates. Additionally, a preliminary sand shading study was conducted in the first field season (2011) with a subsequent loggerhead nest shading study in the following field season (2012). Although hatching success was not significantly impacted, temperatures were significantly reduced in the majority of shaded nests. This practice may not be immediately applicable as a means of managing sex ratios, but it could be used to reverse the temperature effects of nest relocation.

ACKNOWLEDGMENTS

I would be remiss if I did not acknowledge the scores of those who helped me along this journey. First, my friends and family that have supported me in this endeavor especially Carole Virginia Schwoerer, Kari Charron, Kami Weaver, Eric Morris, Angela Tringali, and Beth Hudson. I thank my thesis committee chair and faculty advisor Dr. Betsy Von Holle and my committee members Dr. John Weishampel (whose invaluable input and advice helped me through the bumps in the road) and Dr. Kate Mansfield (who joined my thesis committee under extenuating circumstances on short notice, without hesitation).

Dr. Llewellyn Ehrhart and the members of the UCF Marine Turtle Research Group, particularly Cheryl Sanchez, Simona Ceriani, Chris Long, Alli Hays, Ryan Chabot, Kendra Cope, and Andrew Sterner have provided such a welcoming environment, sharing your knowledge and experience, whom I am as proud to call my colleagues as I am my friends. I want to thank Karissa LeFevre, Lee Schwoerer, Robert Papson, Steve Messier, and Scott Duncan for lab and field assistance. My lab mates, Kirsten Martin, Annie Weeks, Annette Spivy and particularly Steffan Pierre. I cannot imagine completing this thesis without Steffan's perpetually upbeat attitude, incredible patience, and never-ending support. I also thank Dr. Pedro Quintana-Ascencio for his insight, encouragement, and support in the final stages of completing my thesis.

I also acknowledge the NPS personnel at both parks from which my thesis research was based: John Stiner, Mike Daley (for always lending practical advice out in the field), Zandy Hillis-Starr, and Ian Lundgren. Thanks to the NPS volunteers, interns, and research assistants at both CANA and BUIS for their long-term and continued survey efforts.

Field work at Canaveral National Seashore was approved by the UCF Institutional Animal Care and Use Committee (11-23W) and Marine Turtle Permits 11-005-A and 12-005-A.

TABLE OF CONTENTS

LIST OF FIGURES	vii
LIST OF TABLES	xi
BACKGROUND	1
CHAPTER ONE: RELATING SEA SURFACE TEMPERATURE TO THE NESTING PHENOLOGY OF HAWKSBILL SEA TURTLES (<i>ERETMOCHELYS IMBRICATA</i>) AT BUCK ISLAND REEF NATIONAL MONUMENT, ST. CROIX, U.S. VIRGIN ISLANDS.....	4
Introduction.....	4
Study Site	5
Methods	7
Analysis	7
Results.....	8
Discussion.....	11
CHAPTER TWO: TESTING THE EFFECTS OF A SHADING PRACTICE TO MITIGATE LOGGERHEAD SEA TURTLE (<i>CARETTA CARETTA</i>) NEST TEMPERATURES IN RESPONSE TO CLIMATE CHANGE.....	15
Introduction.....	15
Study Site	18
Methods	20

Preliminary Shade Study.....	20
Shade Application Study.....	20
Analysis	24
Results.....	25
Discussion.....	29
APPENDIX A: BUIS NESTING BEACH MAP	34
APPENDIX B: PRELIMINARY SHADE STUDY	36
Methods	37
Temperature Monitoring.....	37
Sand Moisture Monitoring.....	39
Analysis	40
Results.....	41
Justification for Shade Application Study	44
APPENDIX C: NEST SHADING MONTE CARLO ANALYSES	45
APPENDIX D: COMPARISON OF MIDDLE THIRD HOURLY TEMPERATURE READINGS FOR NEST PAIRS	49
REFERENCES	55

LIST OF FIGURES

Figure 1: Location of hawksbill phenology study: Buck Island National Reef Monument (17°47'N, 64°37'W), St. Croix, USVI.	6
Figure 2: Total annual hawksbill nests at BUIS (1988-2008). The nests used in the analysis are shown in dark grey and the nests surveyed outside the sampling period (before July and after September) are in light grey.....	9
Figure 3: Relating the average April to May sea surface temperature and median ordinal day of nesting from 1988 to 2008. The dashed lines represent the 95% confidence intervals. ($r^2 = 0.23$; $p = 0.028$).....	10
Figure 4: Relating April to August sea surface temperature and standard deviation of nest distribution (used as a proxy for nesting season length) from 1988 to 2008. The dashed lines represent the 95% confidence intervals. ($r^2 = 0.32$, $p = 0.0077$)	10
Figure 5: Location of loggerhead nest temperature study: Canaveral National Seashore, Florida. Klondike Beach (located between 28°54'N, 80°47'W and 28°42'N, 80°40'W) was the study area used within CANA.....	19
Figure 6: Self-releasing cage design. The cage provides predator exclusion, while mesh dimensions do not inhibit hatchling emergence from the nest. Figure adapted from Addison (1997).	22
Figure 7: A sample of the Monte Carlo analyses of shaded nest and un-shaded sand nest comparisons. Histograms representing a sample of the randomizations of temperature difference calculations. Red lines represent the total observed temperature difference for each pair of treatments. Lines to the right of the histograms indicate shaded sand was significantly cooler, lines to the left of the histogram indicate shaded sand was significantly warmer, and the line within the histogram represents a marginal treatment effect ($p=0.055$). Histograms for each nest pair can be found in Appendix C (Figure 20, Figure 21, and Figure 22).....	26
Figure 8: Monte Carlo analyses of final sand moisture comparisons. The histogram represents randomized differences in moisture by treatment pair (10,000 iterations). The red line represents the total observed difference in moisture for all pairs of nests ($p=0.2822$).	27

Figure 9: Monte Carlo analyses of hatching success comparisons. The histogram represents randomized differences in percent hatching success by treatment pair (10,000 iterations). The red line represents the total observed difference in percent hatching success for all pairs of nests (p=0.1368)..... 27

Figure 10: A comparison of hourly temperature readings for nest pair 16 over the course of the middle third of incubation. See Appendix D for all nest pair comparisons..... 28

Figure 11: A comparison of hourly temperature readings for nest pairs over the course of the middle third of incubation. Examples of pairs where the shading technique reduced daily temperature variation. 28

Figure 12: A comparison of hourly temperature readings for nest pair 18 over the course of the middle third of incubation, with the upper limit of TRTs indicated by dashed lines (Mrosovsky 1988; Blair 2005; Rodgers 2013)..... 31

Figure 13: BUIS’s turtle nesting beach (17°47'13"N, 64°37'9"W) is divided into four sections: North Shore, West Beach, South Shore, and Turtle Bay. (Maps Copyright NPS, provided courtesy Lundgren)..... 35

Figure 14: Preliminary shade study: temperature monitoring block layout. A block consisted of three plots, one representing each treatment. The plots were spaced 2 m apart and placed in a randomized order. 39

Figure 15: Preliminary shade study: sand moisture monitoring block layout, an example of the random arrangement of treatments. Dark grey represents shaded, light grey represents un-shaded. 40

Figure 16: Monte Carlo analyses of shaded sand and un-shaded sand pair comparisons. Histograms representing each of nine randomizations of temperature difference calculations (1,000 iterations). Red lines represent the total observed temperature difference for each pair of treatments. Lines to the right of the histograms indicate shaded sand was significantly cooler (7/9), and lines to the left of the histogram indicate shaded sand was significantly warmer (2/9). 42

Figure 17: Monte Carlo analyses of un-shaded sand and un-shaded nest pair comparisons. Histograms representing each of two randomizations of temperature difference calculations (1,000 iterations). Red lines represent the total observed temperature difference for each pair of

treatments. Lines to the right of the histograms indicate un-shaded nest was significantly warmer than un-shaded sand (2/2). 42

Figure 18: Histogram representing 10,000 randomizations of moisture difference calculations. The red line represents total observed moisture difference (3.975%) with marginal treatment effect ($p=0.065$)..... 43

Figure 19: Mean percent sand moisture by day comparing shaded and un-shaded sand treatments. 43

Figure 20: Monte Carlo analyses of shaded nest and un-shaded sand nest comparisons (pairs 1-7). Each histogram represents the randomizations of temperature difference calculations. Red lines represent the total observed temperature difference for each pair of treatments. Lines to the right of the histograms indicate shaded sand was significantly cooler. 46

Figure 21: Monte Carlo analyses of shaded nest and un-shaded sand nest comparisons (pairs 9-16). Histograms represent the randomizations of temperature difference calculations. Red lines represent the total observed temperature difference for each pair of treatments. Lines to the right of the histograms indicate shaded sand was significantly cooler, lines to the left of the histogram indicate shaded sand was significantly warmer. 47

Figure 22: Monte Carlo analyses of shaded nest and un-shaded sand nest comparisons (pairs 17-21). Histogram represent the randomizations of temperature difference calculations. Red lines represent the total observed temperature difference for each pair of treatments. Lines to the right of the histograms indicate shaded sand was significantly cooler and the line within the histogram represents a marginal treatment effect ($p=0.055$). 48

Figure 23: A comparison of hourly temperature readings for nest pairs 1-4 over the course of the middle third of incubation..... 50

Figure 24: A comparison of hourly temperature readings for nest pairs 5, 6, and 8 over the course of the middle third of incubation. 51

Figure 25: A comparison of hourly temperature readings for nest pairs 10-13 over the course of the middle third of incubation..... 52

Figure 26: A comparison of hourly temperature readings for nest pairs 14-17 over the course of the middle third of incubation..... 53

Figure 27: A comparison of hourly temperature readings for nest pairs 18-21 over the course of the middle third of incubation..... 54

LIST OF TABLES

Table 1: List of nest metrics evaluated in GLM with abbreviations.....	25
Table 2: Summary table for model selection based on AICc.	29
Table 3: Fitted parameters and their statistical significance for the most informative model. Residual standard error: 156.5 on 17 degrees of freedom; Multiple R-squared: 0.421; Adjusted R- squared: 0.3529; F-statistic: 6.181 on 2 and 17 DF; p-value= 0.009607.....	29

BACKGROUND

Rising atmospheric carbon dioxide levels are predicted to result in increased surface air temperatures at a rate of approximately 0.2°C per decade globally (IPCC 2007); the IPCC Fifth Assessment Report (2013) has been completed and is available for review, however material may not be cited until final publication. It is likely that some estimations will be adjusted. Although species have historically shown the ability to adapt to changes in climate, it is inferred that population adaptation may not be able to keep up with the accelerated rate of human-driven climate change (Thomas et al. 2004). Climate change has been shown to affect population dynamics across taxonomic groups (Walther et al. 2002; Parmesan & Yohe 2003; Parmesan 2006), and the conservation of global biodiversity must consider these responses.

As water and air temperatures rise in a geographically heterogeneous manner (IPCC 2007) ectotherms such as marine turtles, which are especially sensitive to the temperature of their environment, will be strongly affected (Deutsch et al. 2008). Conservation strategies for these globally imperiled species must consider the various threats to conservation posed by climate change (Hawkes et al. 2009; Poloczanska et al. 2009; Fuentes et al. 2011). Rising sea surface temperatures may alter marine turtle resource availability (Hawkes et al. 2009) and reproductive phenology (Weishampel et al. 2004, 2010; Pike et al. 2006; Hawkes et al. 2007; Mazaris et al. 2009). Climate change-driven sea level rise and increased storm activity and intensity (e.g. tropical cyclones in the western Atlantic) are expected to reduce nesting habitat and increase nest inundation (Hawkes et al. 2007; Fish et al. 2008). Marine turtles, like a variety of reptiles, have temperature-dependent sex determination (TSD) where sex is determined by incubation temperature, with female hatchlings produced at higher temperatures (Yntema & Mrosovsky 1982;

Janzen & Paukstis 1991). Many beaches are already estimated to produce hatchling ratios biased towards females (Mrosovsky 1994; Wibbels 2003). Increased sand temperatures are expected to result in a further sex ratio bias (Witt et al. 2010; Fuentes et al. 2011; Fuentes & Porter 2013); likewise, nest temperatures beyond the thermal tolerance range can result in nest failure (Fuentes et al. 2011). An understanding of how marine turtles are affected by the various environmental impacts associated with global climate change is necessary in order to direct conservation efforts.

There are, however, gaps in knowledge in the relationship between sea surface temperature (SST) and the nesting phenology of marine turtles. Studies on only two of seven marine turtle species have been published: loggerheads (*Caretta caretta*) and green turtles (*Chelonia mydas*) (Weishampel et al. 2004, 2010; Pike et al. 2006; Hawkes et al. 2007; Mazaris et al. 2009). The current study extended climate change research to the phenology of hawksbill (*Eretmochelys imbricata*) sea turtles (as well as to the Caribbean region) by analyzing 21 years nesting and SST data from Buck Island Reef National Monument, St. Croix, U.S. Virgin Islands (USVI), to determine if there was a correlation between the timing of nesting and near shore SST.

This thesis also includes a study addressing the impact of increased nest temperatures on female-biased sex ratios of loggerhead (*Caretta caretta*) hatchlings (and potentially, increased embryo mortality). Although manipulating sex ratios is cautioned it is an area that warrants further investigation, because sex ratio manipulation may become a key management practice to mitigate the effects of climate change on marine turtles upon an increased understanding of how hatchling sex ratios impact adult sex ratios and reproductive ecology (Wibbels 2003). Without human mitigation of temperatures, widespread embryo mortality of sea turtle hatchlings is expected in the next several decades with current rates of climatic warming (Fuentes et al. 2011). These issues

motivate the investigation of methods to reduce marine turtle nest temperatures. The effectiveness of a possible mitigation practice to reduce nest temperatures was tested, using loggerhead sea turtle (*Caretta caretta*) nests as a model system.

CHAPTER ONE: RELATING SEA SURFACE TEMPERATURE TO THE NESTING PHENOLOGY OF HAWKSBILL SEA TURTLES (*ERETMOCHELYS IMBRICATA*) AT BUCK ISLAND REEF NATIONAL MONUMENT, ST. CROIX, U.S. VIRGIN ISLANDS

Introduction

Several studies have demonstrated the relationship between sea surface temperatures and sea turtle nesting behavior. Studies in southern Brevard County, Florida (Weishampel et al. 2004, 2010), at Canaveral National Seashore, Florida (Pike et al. 2006), and at Bald Head Island, North Carolina (Hawkes et al. 2007) demonstrate the relationship between warmer sea surface temperatures (SST) adjacent to nesting beaches and earlier loggerhead (*Caretta caretta*) nesting. Mazaris et al. (2009) found that warmer SSTs near loggerhead foraging grounds in the Mediterranean Sea are related to an earlier start of the nesting season in Greece. Green sea turtles (*Chelonia mydas*) have also demonstrated a similar relationship (Weishampel et al. 2010) in southern Brevard County, although a smaller nesting population at Canaveral National Seashore did not demonstrate a statistically significant relationship with warmer SST and earlier nesting (Pike 2009). Warmer SSTs are correlated with shorter seasons in loggerhead nesting and longer seasons in green turtle nesting, where the standard deviation of the nesting distribution has also been used as a measure of nesting season length (Weishampel et al. 2010). These studies infer temperature sensitivity of two sea turtle species in temperate and subtropical regions. Additionally, the relationship between climate parameters and the nesting of hawksbill sea turtles (*Eretmochelys imbricata*) in a tropical region has been studied, where long term multi-decadal climatic variation was used as a correlate for nesting numbers (del Monte-Luna et al. 2012). The purpose of this the

current study was to determine if there is relationship between SST and the nesting phenology of hawksbills at Buck Island Reef National Monument (hereafter referred to as BUIS).

The hawksbill sea turtle has a circumglobal nesting distribution throughout primarily tropical, but also subtropical regions (Meylan & Donnelly 1999). It is now understood that this endangered species may either maintain a home range near their nesting beach or migrate far distances between nesting seasons to foraging grounds (Musick and Limpus 1997; Plotkin 2003; van Dam et al. 2008; Horrocks et al. 2011; Hawkes et al. 2012; Moncada et al. 2012), and their diet consists primarily of sponges (Meylan 1988; van Dam and Diez 1997; León and Bjorndal 2002; Rincon-Diaz et al. 2011; Berube et al. 2012) but also zoanthids (Mayor et al. 1996; Pemberton 2000) within Caribbean waters.

The first objective was to investigate the relationship between SST and the timing of hawksbill nesting. Mean SST (during the months prior to the peak of the hawksbill nesting) was hypothesized to be related to the timing of nesting at BUIS. Warmer SST was predicted to be associated with an earlier median hawksbill nesting date.

The second objective was to investigate the relationship between SST and nesting season duration. Mean SST (during the months prior to and through the peak of the nesting season) was predicted to be related to nesting season duration, and warmer SST was predicted to be associated with a longer nesting season.

Study Site

Buck Island Reef National Monument was designated in 1961 and is managed by the National Park Service. The National Monument includes a 71 hectare uninhabited island, with four

distinct nesting areas totaling approximately 1.5 km of shoreline available for nesting (Appendix A), surrounded by 285 hectares of ocean and coral reef system. The island is located 2.4 km northeast of St. Croix, U.S. Virgin Islands (17° 47'N, 64° 37'W) (Figure 1). This nesting site lies centrally within the northern and southern latitudinal extents (25°N and 8°N respectively) of hawksbill nesting within Caribbean waters (NMFS & USFWS 2013),

BUIS represents an important rookery for the endangered hawksbill sea turtle (Meylan 1999) where marine turtle nesting surveys have been completed since 1988 (Hillis-Starr & Phillips 2002). BUIS serves as one of only eleven hawksbill nesting sites worldwide that has continuous quantitative datasets for periods of 20 or more years; it is also falls in the minority of sites with recent increasing trends in nesting (NMFS & USFWS 2013).

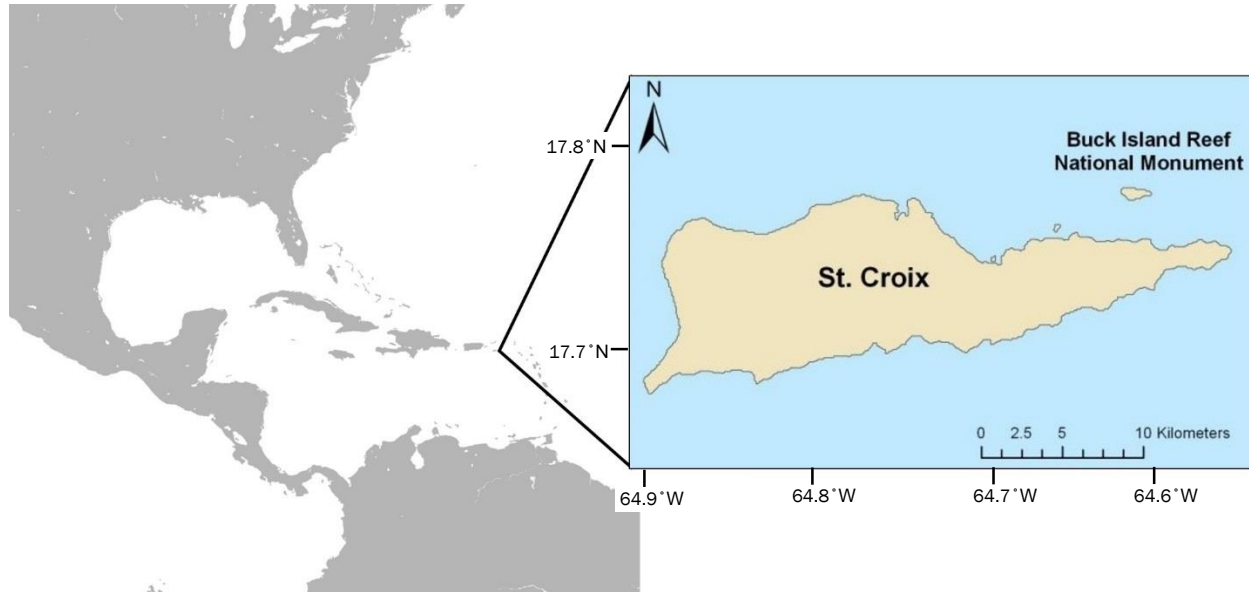

Figure 1: Location of hawksbill phenology study: Buck Island National Reef Monument (17°47'N, 64°37'W), St. Croix, USVI.

Methods

Sea turtle nesting is monitored in accordance with BUIS standardized protocol (Hillis-Starr & Phillips 2002). Currently low-level monitoring occurs throughout the year, with intensified effort between the months of July and October, which coincides with peak nesting (Hillis-Starr & Phillips 2002). This analysis focused on the months in which nest data were collected nightly (except when prevented by extreme conditions) since survey effort has not been consistent across years. The sampling window was narrowed to 1 July – 30 September, which was included in all survey years from 1988 to 2008. Since 2009, consistent sampling has been limited to August and September. Therefore the analysis was limited to 1988-2008 in order to encompass the largest time window with consistent monitoring.

Sea surface temperature data were obtained for the years of 1988 to 2011 using the Reynolds Optimally Interpolated SST dataset which is derived using both *in situ* data from buoys and AVHRR satellite data (Reynolds et al. 2007) from the Physical Oceanography Distributed Active Archive Center (PO.DAAC 2012). The temporal and spatial resolutions used were monthly at 1° x 1°, respectively.

Analysis

Ordinal dates within the survey time frame were weighted by nest number, and standard statistical descriptors (e.g. mean, median, mode, standard deviation) were used to characterize hawksbill nesting frequency for the annual sampling window. Hawksbill nesting has been recorded during every month of the year and consistent sampling only occurs for a three month period (Hillis-Starr & Phillips 2002), therefore nesting season dispersion was measured by standard

deviation instead of season start and end dates. Changes in phenological metrics were evaluated over the 21-year period (1988-2008), and a linear regression analysis was used to evaluate whether the phenological metrics relate to average SST following previous nesting phenology studies to allow comparison (Weishampel et al. 2004, 2010; Pike et al. 2006; Pike 2009).

Results

Annual nest counts used to determine median nesting date and nesting season dispersion for the three month sampling window within the 21-year period ranged from 41 to 181 (Figure 2). The median nesting dates ranged from August 12th – August 27th (ordinal dates 224 – 239) and the average April-May SST adjacent to BUIS were significantly correlated with median nesting date (Figure 3). The prediction that warmer temperatures were associated with earlier nesting was not supported; instead warmer temperatures were associated with later nesting. Median nesting date did not advance significantly through the 21-year scope of the study ($r^2 = 0.0017$; $p = 0.86$). A significant correlation was found between average April-August SST and the SD of nest distribution, a proxy for nesting season length (Figure 4). The prediction that warmer temperatures were associated with a longer nesting season was supported.

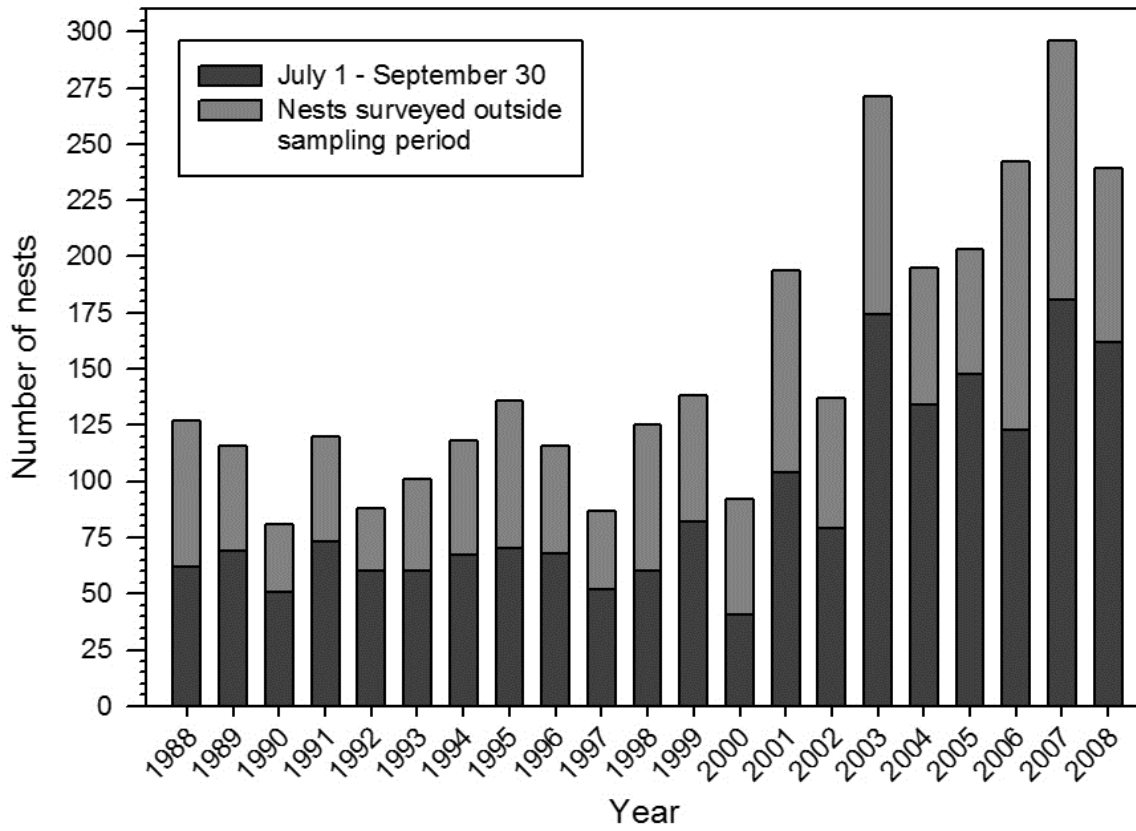

Figure 2: Total annual hawksbill nests at BUIS (1988-2008). The nests used in the analysis are shown in dark grey and the nests surveyed outside the sampling period (before July and after September) are in light grey.

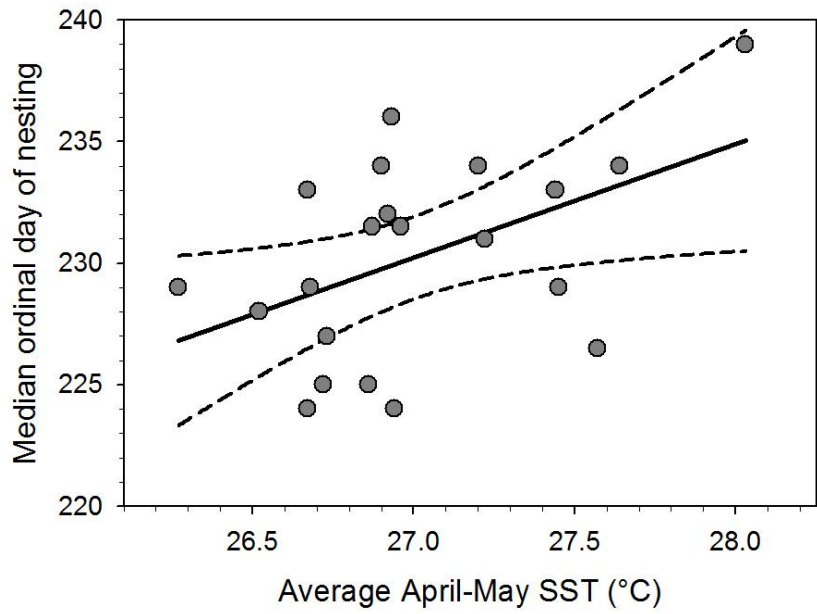

Figure 3: Relating the average April to May sea surface temperature and median ordinal day of nesting from 1988 to 2008. The dashed lines represent the 95% confidence intervals. ($r^2 = 0.23$; $p = 0.028$)

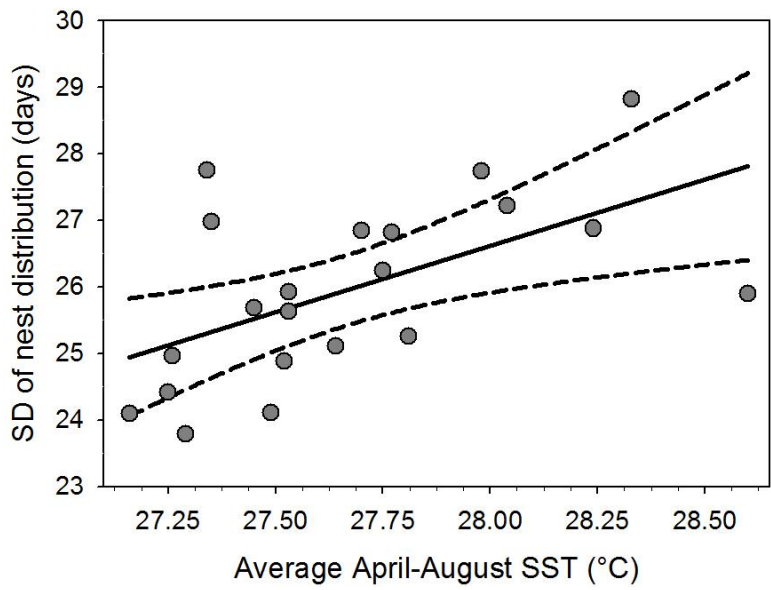

Figure 4: Relating April to August sea surface temperature and standard deviation of nest distribution (used as a proxy for nesting season length) from 1988 to 2008. The dashed lines represent the 95% confidence intervals. ($r^2 = 0.32$, $p = 0.0077$)

Discussion

Although loggerhead and green turtles studied in temperate and subtropical latitudes nested earlier in association with warmer SSTs (Weishampel et al. 2004, 2010; Pike et al. 2006; Hawkes et al. 2007; Mazaris et al. 2009), this study found that warmer SSTs temperatures are associated with later nesting for hawksbills at BUIS, with a 1°C increase being associated with a ~4.5 day later median nesting date. This opens the question as to why hawksbills demonstrate an opposite phenology associated with warming temperatures as compared to other marine turtles.

Generally, warmer temperatures are associated with earlier onset of reproductive activities; however, the vast majority these studies are concentrated in higher latitudes (Von Holle et al. 2010). This study demonstrates a phenology that counters the majority of phenological studies. Recent studies in warmer climates have also shown similar phenological responses to the current study (Von Holle et al. 2010; Gordo & Doi 2012). Von Holle et al. (2010) found that later flowering was exhibited by Floridian plants in association with increased variability in climate over historical time. Also, Gordo and Doi (2012) found that first singing dates are delayed for the Japanese bush warbler in recent decades in subtropical islands of Japan.

One possible explanation for the delay in nesting may be extended foraging time prior to nesting related to the decline of Caribbean sponge and coral (including zoanthid) communities associated with climate change (Vicente 1989; Hoegh-Guldberg 1999; Wulff 2006; Przeslawski et al. 2008). The ability to find ample forage influences the time between a female's nesting seasons because of the importance of gaining adequate energy for both egg production and migration. For example, the female remigration probability of pelagic feeding Pacific leatherbacks (*Dermochelys coriacea*) are associated with El Niño/La Niña events, which are directly related to

resource availability (Saba et al. 2007). Also, during periods of feeding away from nesting sites it has been found that adult female hawksbill dive duration decreases with increased temperatures (Storch et al. 2005). Shorter dives may result in the need for an increased number of dives necessary to find adequate forage needed to nest, which may in turn delay a return to nesting grounds in warmer years.

Shifts in the timing of nesting can affect sex ratios and embryo mortality. This relationship between timing of nesting and SST should be considered when predicting future nest incubation conditions. Models demonstrate that earlier nesting by eastern Pacific leatherbacks may slow their decline from 9% to 4% per decade with earlier nesting (Saba et al. 2012). However unpublished data show an advancement in median nesting date over the past decade (N. Robinson, in Saba et al. 2012). A later median nesting date for hawksbills may ameliorate temperate impacts. If a greater proportion of hawksbills nest later, and during relatively cooler months, the rate of hatchling sex ratio feminization may be reduced. As it is estimated, based on histological examination of dead hatchlings, that hatchling sex ratios at BUIS are already highly female biased (Wibbels et al. 1999).

For hawksbills at BUIS, warmer SSTs are associated with longer nesting season duration. This trend is common with green turtles (*Chelonia mydas*) studied in southern Brevard County (Weishampel et al. 2010). Nesting season duration can be associated with inter-nesting interval where energy stores must be conserved (Walcott et al. 2012). Hawksbills nest at approximately two week intervals at many sites (Witzell 1983; NMFS & USFWS 2013). Also, as the number of clutches per female varies between three and five (Richardson et al. 1999; Beggs et al. 2007), an increase in clutch frequency can extend nesting season duration. Although the peak of nesting occurs during hurricane season, a longer nesting season paired with low-level nesting throughout

the year may ease the vulnerability of nests to hurricanes (Pike & Stiner 2007) which are predicted to increase in intensity and frequency in association with climate change (IPCC 2007).

Increased hawksbill nest numbers over the past two decades at BUIS should be considered with respect to both aspects of the timing of nesting. This increase is likely associated with the reduction in turtle harvest and the enactment of the U.S. Endangered Species Act (1974) and Convention on International Trade in Endangered Species of Wild Fauna and Flora (1973). The timing of nesting for the new nesters may influence the overall pattern, meanwhile experienced breeders may continue to nest at consistent intervals. Therefore population increase may be a confounding factor. Also, because the mean remigration interval for hawksbills at BUIS is 2.9 years (Woody et al. 2005), a different subset of hawksbills are nesting on the shores of BUIS each year. Primack et al. (2009) has found intraspecific variability in phenologies across several taxa (including plants, birds, amphibians, and insects). As it is important not to generalize a species' response to changing temperatures, investigating timing of nesting and SSTs of hawksbill nesting beaches across the Caribbean would provide an opportunity to determine if this relationship is consistent from site to site.

Consideration of the hawksbill seasonal nesting trends at BUIS and throughout the Caribbean (as well as other long-lived species recovering severe historical population declines) must be done in light of what these existing the populations represent. As population recovery occurs, increased nesting could in effect add to the existing annual nesting distribution in an uneven manner, and this could be read as a phenological shift because it does not follow the recent nesting trends. The long-term saturation tagging of nesting females BUIS (Hillis-Starr & Phillips 2002) could provide a means of addressing this possibility in determining which females are contributing

to differences in nesting season distribution. Modern nesting surveys are observations of remnant populations, and the concept of nesting season is based on very short term observations for these long-lived species; “long-term” nesting data are available, but are still only a recent snapshot in comparison to the generations of nesting that occurred prior to European influence on the West Indies (Jackson 1997; Bjorndal & Jackson 2002).

CHAPTER TWO: TESTING THE EFFECTS OF A SHADING PRACTICE TO MITIGATE LOGGERHEAD SEA TURTLE (*CARETTA CARETTA*) NEST TEMPERATURES IN RESPONSE TO CLIMATE CHANGE

Introduction

Marine turtles, like many other reptiles, have temperature-dependent sex determination (TSD) (Janzen 1994) that occurs during the middle third of incubation, known as the critical period or thermosensitive period (Yntema & Mrosovsky 1982). The thermosensitive period is when the sex of a sea turtle is determined primarily by thermal conditions (Yntema & Mrosovsky 1982). The transitional range of temperatures (TRT) is the range of temperatures over which both males and females are produced, with the pivotal temperature being the constant incubation temperature in which a 1:1 ratio of males and females are produced (Mrosovsky & Pieau 1991). Clutches of marine turtles and other reptiles that exhibit Male-Female TSD produce 100% females above the TRT and 100% males below the TRT. Based on constant temperature incubation studies, it is estimated that the TRT for loggerheads in the United States is between 27.5°C and 30.5°C, and the pivotal temperature is approximately 29°C (Mrosovsky 1988).

Loggerhead (*Caretta caretta*) rookeries on the east coast of Florida are believed to produce 87-99.9% female hatchlings based on studies from Hobe Sound (Mrosovsky 1988), Cape Canaveral Air Force Station (Mrosovsky & Pieau 1991), and Hutchinson Island (Hanson et al. 1998). These estimates, which are derived from clutch temperatures and gonadal examination of dead hatchlings, raise concern regarding a current lack of production in male hatchlings on Florida nesting beaches. Recently, the technique of rearing hatchlings up to a size that allows for direct sex determination by laproscopic examination of gonads has been used (Wyneken et al. 2007); studies using this technique to sex hatchlings collected from nesting sites along the southeastern

Atlantic coast resulted in percentages of females ranging from 78-89% female depending on the sample year (Blair 2005; Rodgers 2013).

Regardless of current ratios, sex ratios are expected to become more female biased due to increased air temperatures with climate change (Hawkes et al. 2007, 2009; Poloczanska et al. 2009; Witt et al. 2010; Fuentes et al. 2011). Air temperatures have increased significantly in the summer and fall months in Florida over the last century (Von Holle et al. 2010), which is significant for loggerheads because they nest primarily during the summer. Also, an increase in nest temperatures beyond the thermal tolerance range is expected to increase embryo mortality (Janzen 1994; Mrosovsky et al. 2002).

Although Fisherian theory suggests a population at equilibrium should have a 1:1 male to female sex ratio (Fisher 1930), several hypotheses have attempted to explain the evolutionary significance of sex ratio bias (Bull & Charnov 1989; Girondot & Pieau 1999; Shine 1999; Warner & Shine 2008). It has been asserted that manipulating sex ratios towards a female bias to increase populations is a useful management technique, because one male can mate with multiple females (Wibbels 2007). Studies indicate that the remigration interval is shorter for male marine turtles, which may in effect balance the operational sex ratio (Hays et al. 2010; Schofield et al. 2010; Varo-Cruz et al. 2013). The reduction of nest temperatures to increase the proportion of male hatchlings is cautioned as a climate mitigation technique because the manipulation of sex ratios in conservation warrants a greater understanding of marine turtle reproductive ecology (Wibbels 2003).

Also, it has been suggested that marine turtle populations may nest on particular beaches to produce particular sex ratios or alternatively evolve pivotal temperatures to nesting beaches, in

turn maximizing reproductive output (Wibbels 2007). Given that the majority of marine turtle populations have suffered severe historical decline, a shift towards female biased hatchling sex ratios may be an adaptation in population recovery. Regardless of the evolutionary means by which marine turtles have come to produce the range of hatchling sex ratios across nesting beaches, climate change is likely to increase production of females (and eventually increase embryo mortality) given the assumption marine turtles continue to nest in the same places (site fidelity) at the same times (phenology). Although the reduction of nest temperatures to increase the proportion of male hatchlings is cautioned (Wibbels 2003), there is an evident need for an understanding of multiple mitigation options to provide for a multi-pronged approach to marine turtle conservation in response to climate change (Mrosovsky & Godfrey 2010).

One option for mitigating the impacts of climate change on hatchling sex ratios and embryo mortality is the use of shading (Naro-Maciel et al. 1999; Hawkes et al. 2007, 2009; Fuentes et al. 2009, 2011; Mitchell & Janzen 2010). The effects of shade on loggerhead nest temperatures have been tested in Florida by Mrosovsky et al. (1995) in Boca Raton and Schmid et al. (2008) on Keewaydin Island. These studies addressed the effects of shading by condominiums (Mrosovsky et al. 1995) and the invasive tree Australian pine (*Casuarina equisetifolia*) (Schmid et al. 2008). In both cases, the temperature reductions associated with partial shading did not demonstrate statistically significant effects on the sand temperatures, but a study involving the direct shading of *in situ* loggerhead nests has not yet been published. In this study a shading technique to reduce nest temperatures with the intent to balance sex ratios and increase hatching success was tested at Canaveral National Seashore, an important rookery for loggerhead sea turtles (Antworth et al. 2006).

The objective of the study was to determine the temperature effects of shading loggerhead nests with the proposed mitigation technique. Mean temperature (during the middle third of incubation) was hypothesized to be significantly different when comparing shaded and un-shaded loggerhead nests. Shaded nest treatments were predicted to have significantly lower mean temperature on average in comparison to un-shaded nests.

Study Site

Canaveral National Seashore (CANA) is located on the Atlantic coast of central Florida, spanning southern Volusia County and northern Brevard County (Figure 5). Established in 1975, CANA serves as a nesting beach for three species of sea turtle. Since 1984, CANA personnel have completed nesting beach surveys, monitoring the nesting activity of loggerhead (*Caretta caretta*), green (*Chelonia mydas*), and leatherback (*Dermochelys coriacea*) sea turtles. Infrequent nesting of hawksbill (*Eretmochelys imbricata*) and Kemp's ridley (*Lepidochelys kempii*) sea turtles also occurs. Nesting activity is monitored from April through October with beach patrols from May through August completed seven days a week during the hours of 11:00 PM to 7:30 AM. Loggerheads are the dominant sea turtle in this system, laying 3,000-4,000 nests within CANA boundaries per year. The nearly 39 km stretch of undeveloped barrier island includes approximately 19 km of shoreline that has limited public access and is designated as a backcountry area. This stretch of shoreline, known as Klondike Beach, is located between 28° 54'N, 80°47'W and 28°42'N, 80°40'W and was the study area within the park (Keller et al. 2008).

This site was ideal for the study because of the availability of a backcountry area only accessed by the occasional hiker, therefore the concern for public disturbance of the experiment

was reduced. The location of all sea turtle nests at CANA are marked and screened for predator exclusion, therefore the risk of disturbing surrounding nests was eliminated in the course of the experiment. Also, the relatively high loggerhead nesting density (Witherington et al. 2009) allowed for locating nests in relative close proximity for paired treatments.

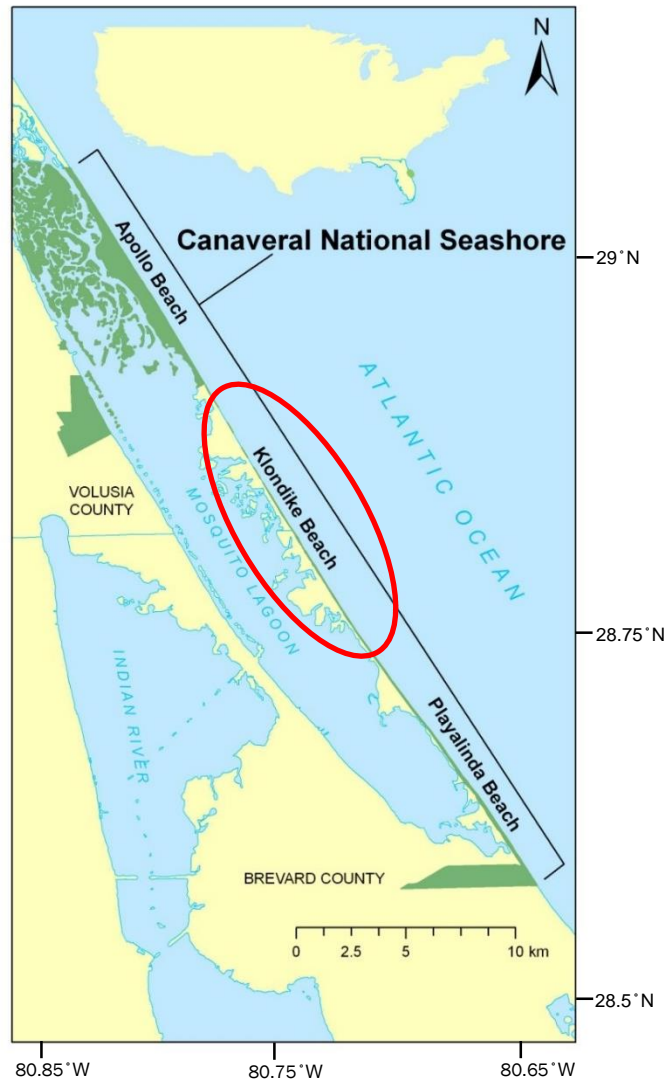

Figure 5: Location of loggerhead nest temperature study: Canaveral National Seashore, Florida. Klondike Beach (located between 28°54'N, 80°47'W and 28°42'N, 80°40'W) was the study area used within CANA.

Methods

Preliminary Shade Study

A preliminary study was completed during the summer of 2011 and was used to inform the predictions of how the application of shade to a loggerhead nest would affect the nesting environment. Predictions were used to determine if the shade technique was appropriate to apply to loggerhead nests. Experiments included temperature comparisons of shaded sand and un-shaded sand treatments, temperature comparisons of un-shaded nest and un-shaded sand treatments, and comparisons of sand moisture over time between shaded sand and un-shaded sand treatments. Monte Carlo techniques were used to analyze both temperature and moisture data. Based on the evaluation of results from the preliminary study, which showed significant cooling effects of shade in the majority of nests and a marginal treatment effect in moisture, the determination was made to test the shade technique on loggerhead nests. Methods, analyses, and results from this preliminary study are detailed in Appendix B.

Shade Application Study

Shaded and un-shaded nest treatments were deployed for 21 pairs of loggerhead nests during June and July 2012. The initial nest in a pair was selected by locating a nesting female within the study area, a single data logger was opportunistically placed in the center of the nest during egg deposition. One of the two treatments was assigned at random, by blindly selecting a data logger for the nest (data loggers were grouped in pairs and pre-labeled for treatment). When a second, nearby nesting female was encountered, her nest was selected for the second treatment. To reduce the heterogeneity of nesting environments across the study area and throughout the

nesting season, the second nest was chosen if it was located at a similar distance to the spring high tide line and laid within one day of the initial nest. Each nest received one of two treatments: self-releasing cage without shade cloth (control) or self-releasing cage with shade cloth (treatment). A single data logger was placed in the center each nest for each replicate.

Self-releasing cages were inserted 30.5 cm below the sand level by digging trenches to fit the cage dimensions (Figure 6). Self-releasing cages were originally designed for predator exclusion but allow for hatchlings to emerge without restraint (Addison & Henricy 1994; Addison 1997). The cages were constructed and deployed following Marine Turtle Conservation Guidelines (FWC 2007); cages were used in both shaded and un-shaded treatments to control for temperature effects due to the cage. Cages deployed in the shaded treatments were adapted to provide shade by attaching a shade cloth to the top surface of the cage. Shade cloth made from unbleached 100% Osnaburg cotton was chosen for this study because it is semipermeable which is expected to reduce sand moisture effects. Sand moisture content is a relevant consideration because the hydric environment of a nest has also been shown to influence the sex of turtles with temperature-dependent sex determination (LeBlanc & Wibbels 2009). The cloth is off-white in color therefore having a high albedo. Traditional shade cloth composed of polyethylene was not selected for use because of evidence of many plastics leaching environmental estrogens. A hem and grommet finish was used on the edges of the cloth to reduce fray and provide a means of attaching the cloth to the upper surface of the self-releasing cage using cable ties.

Nest temperatures were monitored using waterproof HOBOTM temperature data loggers (Onset Computer Corporation). The temperature data loggers have a resolution of 0.1 °C and accuracy rating of ± 0.53 , but with an accuracy check it was determined that all but five (which

consistently recorded temperatures 0.1 °C cooler) data loggers used were consistently recording the same temperatures. This difference does not influence the significance of the results of the current study, therefore no adjustments were made to the calculations. Each data logger (5.8 x 3.3 x 2.3 cm) can be programmed to record ambient temperature for a variety of time intervals. Mean clutch volume for Florida loggerhead nests is 4,425.0 cm³ (SD=843.2) (Tiwari & Bjorndal 2000), therefore one data logger represents only 0.72-1.6% of the clutch volume for 95% of loggerhead nests and is not expected to interfere with the thermal conditions of the nest or the movement of hatchlings during emergence. Temperature data loggers of comparable proportions (5.8 × 4.4 × 1.7 cm) were used with success by Hanson et al. (1998) in a loggerhead nest temperature study.

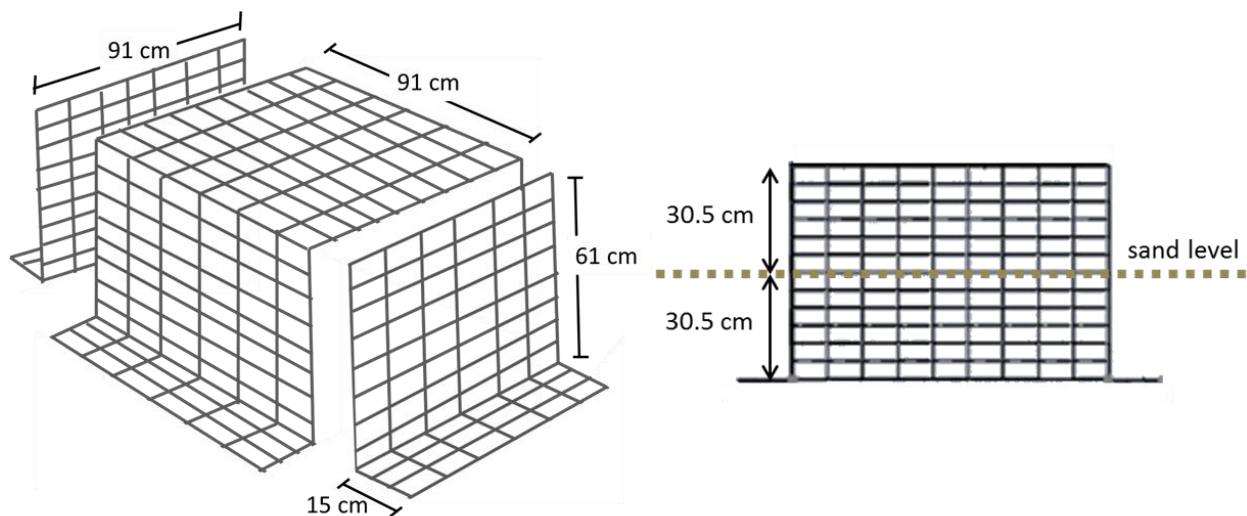

Figure 6: Self-releasing cage design. The cage provides predator exclusion, while mesh dimensions do not inhibit hatchling emergence from the nest. Figure adapted from Addison (1997).

The data-loggers were deployed in the center of the clutch during egg deposition (Hanson et al. 1998; Schmid et al. 2008). The center of the clutch was estimated, based on the 110 mean clutch size for loggerheads at CANA. Data loggers recorded treatment temperatures at 1 hour intervals for the duration of the incubation period. Previous studies employing data loggers to measure nest temperatures used recording intervals ranging from 1 hour to 4 hours (Mrosovsky &

Provancha 1992; Hanson et al. 1998; van de Merwe et al. 2006; Zbinden et al. 2006; Tuttle & Rostal 2010). The recording interval for this study was chosen based on the memory capacity of the data loggers.

Nests were monitored throughout the incubation period by CANA personnel for proper cage placement and signs of depredation. Beginning 45 days following clutch deposition, the nests were monitored daily for signs of hatchling emergence. Three days after signs of hatching emergence (or 70 days after egg deposition) cages were removed, data-loggers were excavated, and hatching success evaluation were completed (FWC 2007).

Various measurements were taken for each nest at the time of deployment and as part of the hatching success evaluation, each of these measurements can influence nest temperature. The location along the width of the beach (measured by both distance to wrack line and distance to vegetation) determines the tidal influence on a clutch, with clutches closer to the dunes having a reduced cooling effect from tides. Reduced clutch size and hatching success both can have temperature reducing effects in association with metabolic heating. The depth of a nest determines the impact of solar influence on the daily variation of nest temperatures. Distance between two clutches in a pair can increase the heterogeneity in sand characteristics, and the date laid determines the temperature variations experienced through the length of incubation. Sand moisture may also influence nest temperature through evaporative cooling, and have a direct influence on sex determination (LeBlanc & Wibbels 2009).

Analysis

A Monte Carlo analysis (Manly 1991) was applied to each of the 20 pairs of nests in which data loggers were retrieved for both un-shaded and shaded nest treatments. Each analysis compared the total difference in hourly temperature readings (un-shaded minus shaded) over the course of the middle third of incubation (total observed temperature difference °C) to a null distribution. The null distribution was created by randomizing pairs of readings at a given time, and totaling the differences in temperature for a given pair. A frequency distribution (from 1,000 iterations of the previously described randomization) was generated to compare to the observed difference for a specific pair of nests. If the total observed differences fell within the null distribution, tail probability was calculated to evaluate the likelihood of such observed differences occurring at random (Gotelli & Ellison 2004). This process was completed for each of the pairs, to determine a proportion of pairs showing a treatment effect.

Monte Carlo analyses were also completed for both hatching success and final sand moisture for across pairs. The difference in hatching success for each pair (un-shaded hatching success minus shaded hatching success) was calculated, then the total of the differences was used as the observed difference in hatching success. The total observed difference was compared to the null distribution created by randomizing pairs of treatments and totaling the differences, with 10,000 iterations; a frequency distribution was generated to compare the observed difference. Tail probabilities were calculated to evaluate the likelihood of such observed differences occurring at random. The same method was used to analyze final sand moisture data (un-shaded moisture minus shaded moisture).

Generalized linear models (GLM) were estimated to evaluate the association between the total temperature differences (as response variable) and other nest metrics (Table 1) influencing temperature differences besides the treatment effect. Total temperature difference between nest pairs was used as the response variable and each of the nest metrics was a possible predictor variable. Nest metrics that were significantly correlated with each other were excluded from the model. Both Monte Carlo and GLM analyses were performed using R statistical software (R Core Team 2013).

Table 1: List of nest metrics evaluated in GLM with abbreviations

Abbreviation	Nest Metric
dDay	Difference in date laid
dClutch	% difference in clutch size
dHS	Difference in % hatch success
dDistVeg	Difference in distance to vegetation (m)
dDistWr	Difference in distance to wrack line (m)
dDepthTop	Difference in depth to top of nest (cm)
distance_km	Distance between nests in pair (km)

Results

One shaded nest (Pair 8) was washed out, but all other nests incubated through hatchling emergence. A significant difference between treatments were detected in 19 out of 20 pairs, and one pair had a marginal treatment effect ($p=0.055$). The total differences in the middle third of incubation temperatures were significantly cooler for the shaded treatment in 17 out of 20 pairs, and significantly warmer in two out of 20 pairs (Figure 7). Treatment effects were not detected when comparing final sand moisture ($p=0.2822$) (Figure 8) or percent hatching success ($p=0.1368$)

(Figure 9). Temperature differences of pairs were also plotted by hour for the middle third of incubation to evaluate temperature variation as it relates to sex determination (Figure 10). Some examples of the shaded nest treatment pairs, however, do show a reduction in daily nest temperature variability (Figure 11).

Several predictor parameters were found to be significantly correlated for the generalized linear model, those parameters were eliminated. Differences in percent hatching success (dHS), distance to wrack (dDistWr), and depth to top of nest (dDepthTop) were used as predictors for difference in temperature between treatments. All possible additive models were tested for these predictors (Table 2), and the most informative model included the difference in hatching success and difference in distance to wrack line between the control and shaded treatments. Model parameters for the most informative model are shown in Table 3.

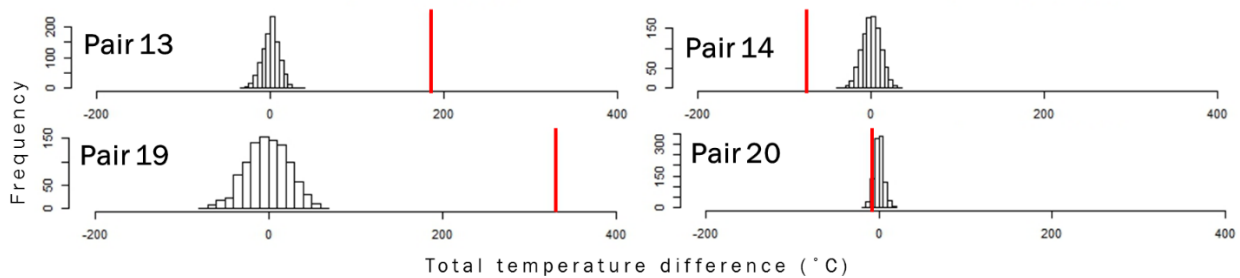

Figure 7: A sample of the Monte Carlo analyses of shaded nest and un-shaded sand nest comparisons. Histograms representing a sample of the randomizations of temperature difference calculations. Red lines represent the total observed temperature difference for each pair of treatments. Lines to the right of the histograms indicate shaded sand was significantly cooler, lines to the left of the histogram indicate shaded sand was significantly warmer, and the line within the histogram represents a marginal treatment effect ($p=0.055$). Histograms for each nest pair can be found in Appendix C (Figure 20, Figure 21, and Figure 22).

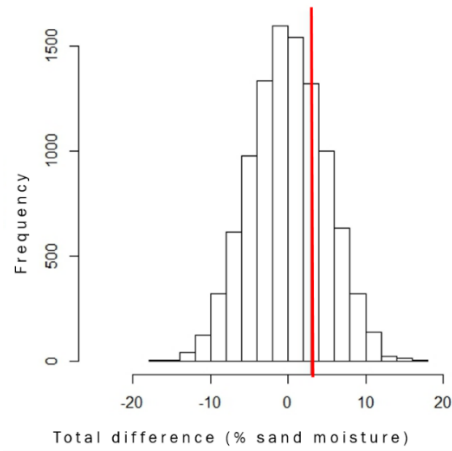

Figure 8: Monte Carlo analyses of final sand moisture comparisons. The histogram represents randomized differences in moisture by treatment pair (10,000 iterations). The red line represents the total observed difference in moisture for all pairs of nests ($p=0.2822$).

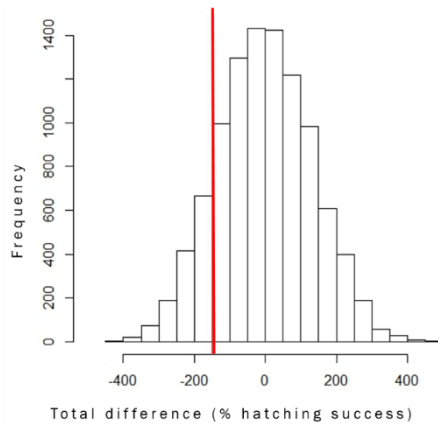

Figure 9: Monte Carlo analyses of hatching success comparisons. The histogram represents randomized differences in percent hatching success by treatment pair (10,000 iterations). The red line represents the total observed difference in percent hatching success for all pairs of nests ($p=0.1368$).

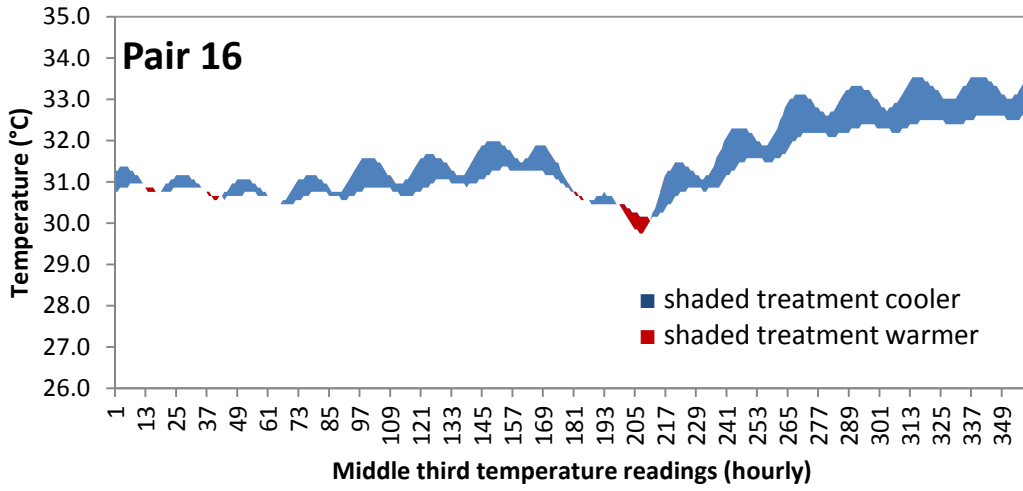

Figure 10: A comparison of hourly temperature readings for nest pair 16 over the course of the middle third of incubation. See Appendix D for all nest pair comparisons.

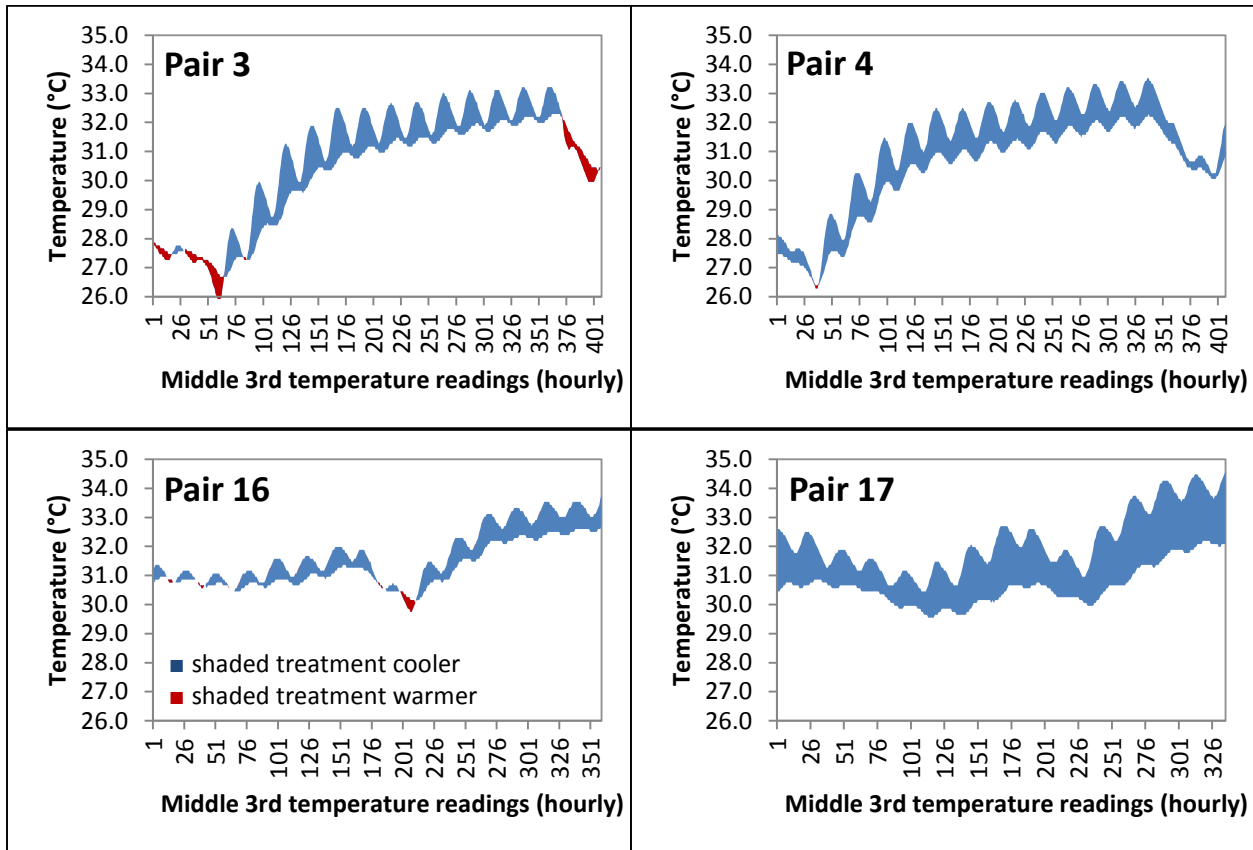

Figure 11: A comparison of hourly temperature readings for nest pairs over the course of the middle third of incubation. Examples of pairs where the shading technique reduced daily temperature variation.

Table 2: Summary table for model selection based on AICc.

Model	K	AICc	Δ AICc	AICc Wt	Cum.Wt	Log-likelihood
dHS + dDistWr	4	266.2907	0	0.3695	0.3695	-127.812
dHS	3	267.3754	1.0847	0.2148	0.5843	-129.9377
dHS + dDistWr + dDepthTop	5	267.7987	1.508	0.1738	0.7581	-126.7565
dHS + dDepthTop	4	268.2221	1.9314	0.1407	0.8988	-128.7777
dDistWr	3	270.3388	4.0481	0.0488	0.9476	-131.4194
NULL MODEL	2	271.2599	4.9692	0.0308	0.9784	-133.277
dDistWr + dDepthTop	4	273.1641	6.8734	0.0119	0.9903	-131.2487
dDepthTop	3	273.5694	7.2786	0.0097	1	-133.0347

Table 3: Fitted parameters and their statistical significance for the most informative model. Residual standard error: 156.5 on 17 degrees of freedom; Multiple R-squared: 0.421; Adjusted R-squared: 0.3529; F-statistic: 6.181 on 2 and 17 DF; p-value= 0.009607.

	Estimate	Std. Error	t value	p value
(Intercept)	228.557	36.316	6.294	8.09e-06
dHS	-352.193	129.604	-2.717	0.0146
dDistWr	14.054	7.004	2.007	0.0610

Discussion

Nest shading did not significantly impact hatching success. This is likely because nests in the study did not experience temperatures that severely impacted hatching success. Nest shading was successful in reducing loggerhead nest temperatures in the majority of nests, without significantly impacting hatching success or sand moisture. Regardless of efforts to select the most similar nests as possible for pairs of treatments, variation was inevitable, given the heterogeneity of the nesting beach and variation in clutch size, clutch placement, and hatching success. Based on the model selection, the differences in hatching success and distance a nest was from the wrack line provided some explanatory power for the differences in nest temperatures. This may account

for the variation in temperature effect beyond the treatment effect. Reduced hatching success would result in less metabolic heating during the thermosensitive period if embryo mortality occurs prior to or during the middle third of incubation. Also, greater differences in the location of a nest along the beach width can have an effect on the temperature difference due to tidal influence.

However the question still remains whether the observed temperature decreases were sufficient to impact sex ratios. Studies by Blair (2005) and Rodgers (2013) on Atlantic loggerhead hatchling nest temperatures found mixed sex ratios in natural nests incubated at mean middle third nest temperatures higher than the boundaries of the transitional range of temperatures than those tested by Mrosovsky (1988). Mrosovsky (1988) had established the transitional range of temperature to range from 26.5-30.5°C and pivotal temperature near 29°C, with constant incubation temperatures in laboratory conditions. Hatchlings reared to adequate size for direct sex determination by laparoscopy (Wyneken et al. 2007) and found to be male were collected from nests ranging in mean middle third incubation temperatures ranging from 26.5-32°C (Blair 2005) and 27.5-34.1°C (Rodgers 2013). These studies call into question the use of mean temperature as an adequate method of estimating the sex ratio of naturally incubating marine turtle clutches. It seems unlikely that the TRT for loggerheads would have shifted over the multi-decade period of these studies. Instead, temperature variability (both daily fluctuation and throughout the critical period) is likely to play a more important role in sex determination than previously considered for naturally incubating nests. An example of temperatures from a nest pair in the present study with each of the upper limits of the TRT found in each of the three previously mentioned studies is presented in Figure 12. Temperature variation has already been demonstrated to play a role in the sex ratio outcome of red-eared sliders, where males are produced at female mean temperatures

when a high degree of fluctuation is introduced (Neuwald & Valenzuela 2011). A study by Georges et al. (1994) on temperature fluctuations during egg incubation of loggerheads showed that greater fluctuations resulted in higher proportions of females than would be estimated by the mean alone. A constant temperature equivalent was calculated to predict these increases. Fluctuations were based around 26 °C, therefore the possibility of the phenomenon demonstrated in red-eared sliders is not addressed. An adaptation of constant temperature equivalent (Georges et al. 1994) or the use of growing-degree days (Allen 1976) might be applied to temperature data to estimate sex ratios relative to nest temperatures. However, as direct sexing of hatchlings was not a part of the current study, such analyses could not be conducted.

Given evidence in recent studies on the high degree of variation in mean temperatures under which males and females are produced, mean temperatures are not presented in this study for sex ratio estimates. How the reduction in variability (Figure 11) impacts sex ratios is not understood for the temperatures experienced, but further study may clarify how the full range of temperatures experienced during the thermosensitive period impacts sex ratios.

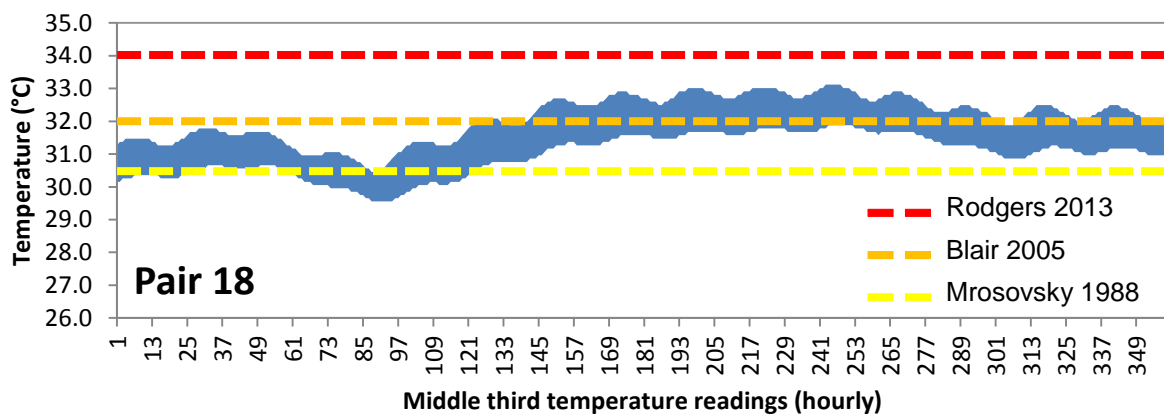

Figure 12: A comparison of hourly temperature readings for nest pair 18 over the course of the middle third of incubation, with the upper limit of TRTs indicated by dashed lines (Mrosovsky 1988; Blair 2005; Rodgers 2013).

The nest shade technique in the current study is easily constructed and transported, allows for nests to remain *in situ*, and generally does not require maintenance during clutch incubation. Other techniques might be able to reach a greater level of temperature reduction but can be difficult to deploy on a larger scale in the field. These include, but are not limited to, the use of white sand (Woody et al. 2005), Styrofoam boxes (Mrosovsky 1994), irrigation (Naro-Maciel et al. 1999), shade combined with irrigation (Jourdan & Fuentes 2013), and hatchery shading where nests are relocated (Patino-Martinez et al. 2012). To reach the desired level of temperature reduction for management purposes this mitigation technique also might be modified (e.g. increasing shade area, different cloth types) and tested to improve the temperature reduction in order to impact fewer clutches to a greater extent. It may also be adapted for use with other marine turtle species upon further testing.

As recent studies show that male production occurs at higher temperatures than previously thought, previously nest feminization estimates may have been exaggerated. However, with ongoing climate change, it is expected that full feminization of nests is inevitable unless adaptation occurs (e.g. TSD plasticity, shifts in nesting sites, phenological shifts). As previously discussed, manipulating sex ratios in management is strongly cautioned without full understanding of marine turtle reproductive ecology (Wibbels 2003), but the shading technique tested in this study may serve as one of many potential mitigation options responding to climate change. For example, this method could be used in those areas which are experiencing nest mortality due to temperatures above their thermal tolerance. Also, the shading of relocated nests should be used when nests are moved further from the high tide line to avoid inundation, as these shifted nests have been shown to significantly increase nest temperature (Foley et al. 2006; Tuttle & Rostal 2010). The nest

shading technique described in this study could be applied to ameliorate those effects, and would allow for a long term validation of the technique beyond the current study.

APPENDIX A: BUIS NESTING BEACH MAP

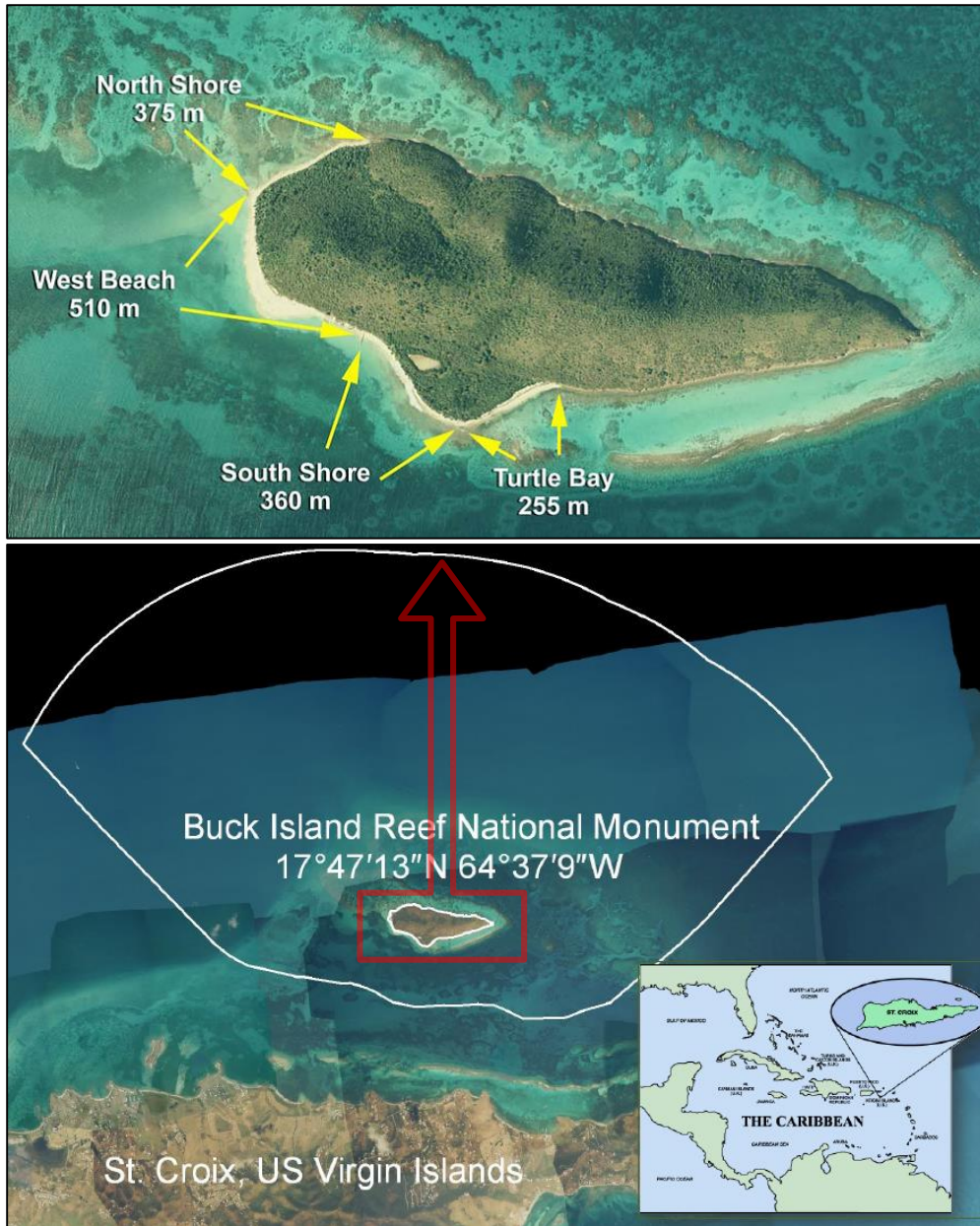

Figure 13: BUIS's turtle nesting beach (17°47'13"N, 64°37'9"W) is divided into four sections: North Shore, West Beach, South Shore, and Turtle Bay. (Maps Copyright NPS, provided courtesy Lundgren)

APPENDIX B: PRELIMINARY SHADE STUDY

Methods

There were two objectives for the preliminary shade study. The first objective was to determine the temperature effects of shading sand with the proposed mitigation technique. Mean temperature (during the second third of the shaded period) was hypothesized to be significantly different when comparing shaded and un-shaded sand. Shaded sand treatments were predicted to have significantly lower mean temperatures (during the second third of the shaded period) on average in comparison to the un-shaded sand treatments. The second objective was to determine the moisture effects of shading sand with the proposed mitigation technique. Sand moisture content was hypothesized to not differ significantly between shaded and un-shaded treatments throughout the study period.

Temperature Monitoring

During the summer of 2011, preliminary data were compiled by recording nest and sand temperatures using temperature data loggers for the following treatments: un-shaded sand, un-shaded nest, and shaded sand. A block configuration was used in order to control for environmental heterogeneity as well as temporal differences. Fifteen replicate blocks were constructed during the months of July and August 2011. Each block contained one plot of each treatment, spaced 2 m apart in a randomized order (Figure 14).

Block locations were established by selecting nests located a minimum of one meter above the spring high tide line, with the objective of using nests that were further from the high tide line and as close to the vegetation as possible to avoid tidal influence and data-logger loss. Prior to 18 August 2011, due to permitting constraints, loggerhead nests were not disturbed but located by

NPS staff and used as reference nests; shaded and un-shaded treatments were deployed adjacent to each of eight reference nests (Figure 14). Beginning 16 August 2011, temperature data loggers were opportunistically deployed in loggerhead nests; a total of seven loggerhead nests received data loggers during the latter portion of the nesting season.

Self-releasing cages were placed over sand in plots adjacent to nests for shaded and un-shaded treatments, also with temperature data loggers deployed. Nests with data loggers were protected from predation by self-releasing cages (Figure 6). Cages covered all treatments with temperature data loggers. Reference nests were protected from predation by placing a 1.2 m x 1.2 m square screens with 5 cm x 10 cm wire mesh over each nest with corners secured by rebar following CANA protocol (Keller et al. 2008). Shaded treatments were adapted to provide shade in the same manner as previously described in the shade application methods.

Nest and sand temperatures were monitored using waterproof HOBO® temperature data loggers (Onset Computer Corporation). For each nest receiving a data-logger, the data-loggers were deployed in the center of the clutch during egg deposition (Hanson et al. 1998; Schmid et al. 2008). The measurement of depth of the data logger was taken using a soft measuring tape once the data logger was deployed at the estimated center of the clutch. The center of the clutch was estimated, based on the 110 mean clutch size for loggerheads at CANA. The data-loggers for the un-shaded and shaded sand treatments were buried at the middle nest depth for the corresponding nest, standardized within each block. The depth at which data loggers were placed for the shaded and un-shaded sand treatments paired with reference nests was determined based on adding 10 cm to the depth to the top of the nest based on mean Florida nest parameters for loggerheads (Tiwari & Bjorndal 2000). All treatments were deployed between the hours of 11 PM and 7 AM. The data

loggers recorded treatment temperatures at 1 hour intervals for the duration of the incubation period.

Nests were monitored throughout the incubation period by CANA personnel for proper cage placement and signs of depredation. Beginning 45 days following clutch deposition, the nests were monitored daily for signs of hatchling emergence. After hatchling emergence within a block, all cages were removed and data-loggers were excavated from each treatment. A hatching success evaluation was completed for all nests in the study (FWC 2007).

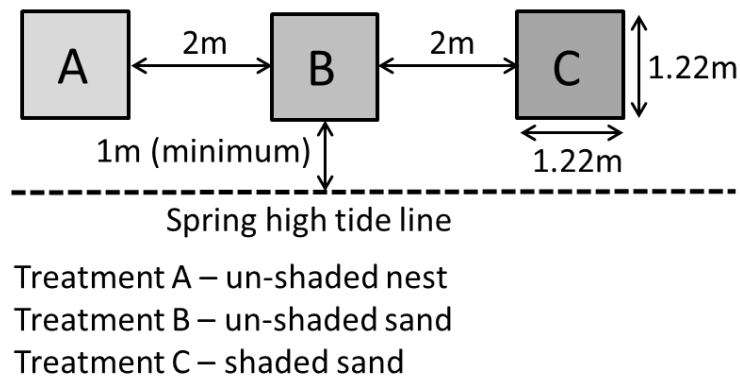

Figure 14: Preliminary shade study: temperature monitoring block layout. A block consisted of three plots, one representing each treatment. The plots were spaced 2 m apart and placed in a randomized order.

Sand Moisture Monitoring

A separate sampling design, to avoid data logger disturbance, was conducted to test for cumulative differences in sand moisture between shaded and un-shaded sand. A block of four shaded plots and four un-shaded plots (Figure 15) were constructed without data loggers during June 2011. The block site was randomly selected within the study area, at a location a minimum of 1 m above the spring high tide line. Grid markers are spaced at ~0.4 km increments along CANA. One was randomly selected from the markers within the boundaries of Klondike Beach with washout prone grid markers excluded. A polygon in ArcMap 9.3.1 (ESRI 2009) was created

for the 0.4 km length of shoreline, with width determined by the distance between 1 m from the spring high tide line and the vegetation. Then a random point, which served as the starting point for the first plot within the block, was generated within each polygon using HawthTools. The remaining seven plots were constructed in a direction parallel to the high tide line, so that all treatments were approximately the same distance to the high tide line. Whether the plots were constructed north or south of the starting point was determined randomly, by a coin flip.

Each of the eight plots within the block were randomly preselected for either treatment (shaded or un-shaded) using a random number table. Sand samples were collected using an auger to the depth of 50 cm, the bottom 20 cm of the sand core was collected and sealed in a plastic bag. Samples were collected from both blocks during days 15 to 47 since deployment. Three shaded and three un-shaded sand samples were collected at random for each visit to the site. Sand moisture was determined following the oven dry method described by Winegardner (1996).

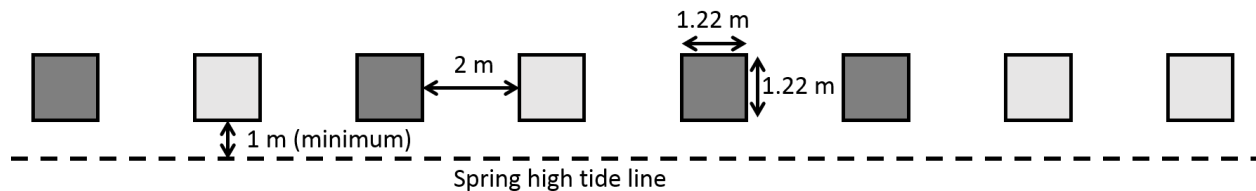

Figure 15: Preliminary shade study: sand moisture monitoring block layout, an example of the random arrangement of treatments. Dark grey represents shaded, light grey represents un-shaded.

Analysis

The nests associated with each block were used to determine the middle third of incubation. A separate Monte Carlo analysis was applied separately to each of the nine blocks in which data loggers were retrieved for both shaded sand and un-shaded sand treatments. Each of the nine temperature analyses compared the total differences in hourly temperature readings (un-shaded

minus shaded) over the course of the “estimated” middle third of incubation (total observed temperature difference °C) to a null distribution. The null distribution was created by randomizing pairs of readings at a given time and totaling the differences in temperature for a pair of treatments, with 1,000 iterations, a frequency distribution was generated to compare to the observed difference. If the total observed differences fell within the null distribution, tail probability was calculated (Gotelli & Ellison 2004). This process was completed for each of nine blocks, to determine a proportion of blocks showing a treatment effect. The un-shaded nest and un-shaded sand temperature data were compared in the same manner for the two blocks in which data loggers were successfully retrieved.

These moisture data were not continuously sampled (e.g. hourly, daily), therefore a total observed moisture difference would not be an appropriate representation of treatment effect. The daily mean moisture, for each treatment, was plotted by day and the area under each line was taken. The differences in areas was used to represent total observed moisture differences between treatments. The daily means were randomized within day, and the areas and total differences were generated (10,000 iterations) to create a null distribution for the Monte Carlo analysis allowing a comparison of the observed difference to those that may have occurred at random. Analyses followed procedures outlined by Manly (1991) using R software (R Core Team 2013).

Results

A significant treatment effect was detected in all comparisons of shaded and un-shaded sand. The total differences in the estimated middle third of incubation temperatures were significantly cooler for the shaded sand treatment in seven out of 9 blocks, and significantly

warmer in two out of nine blocks (Figure 16). A significant treatment effect was also detected in the two un-shaded nest versus un-shaded sand comparisons, with the un-shaded nest being significantly warmer during the middle third of incubation compared to the same time frame for the un-shaded sand (Figure 17).

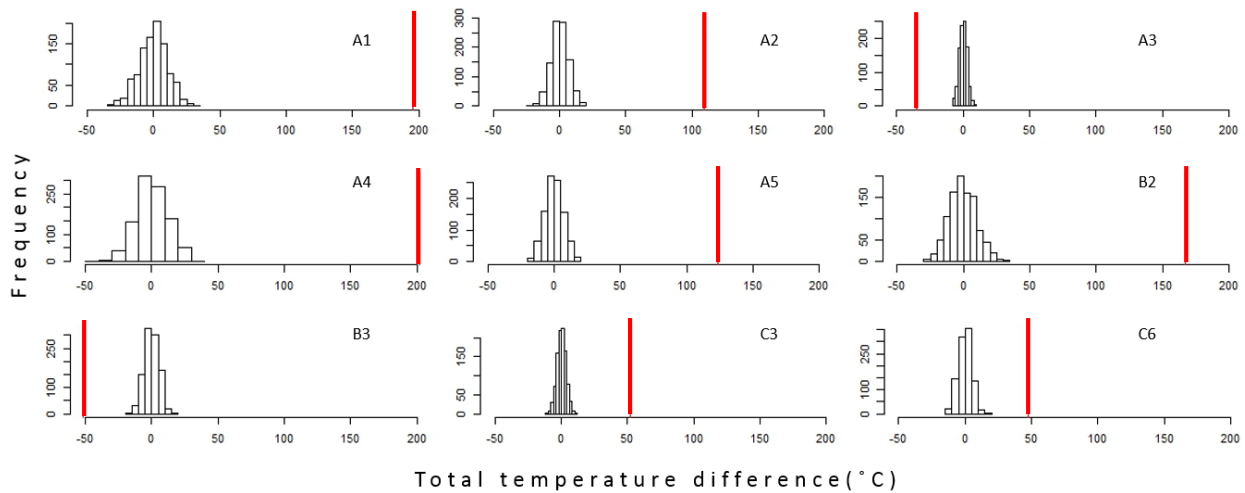

Figure 16: Monte Carlo analyses of shaded sand and un-shaded sand pair comparisons. Histograms representing each of nine randomizations of temperature difference calculations (1,000 iterations). Red lines represent the total observed temperature difference for each pair of treatments. Lines to the right of the histograms indicate shaded sand was significantly cooler (7/9), and lines to the left of the histogram indicate shaded sand was significantly warmer (2/9).

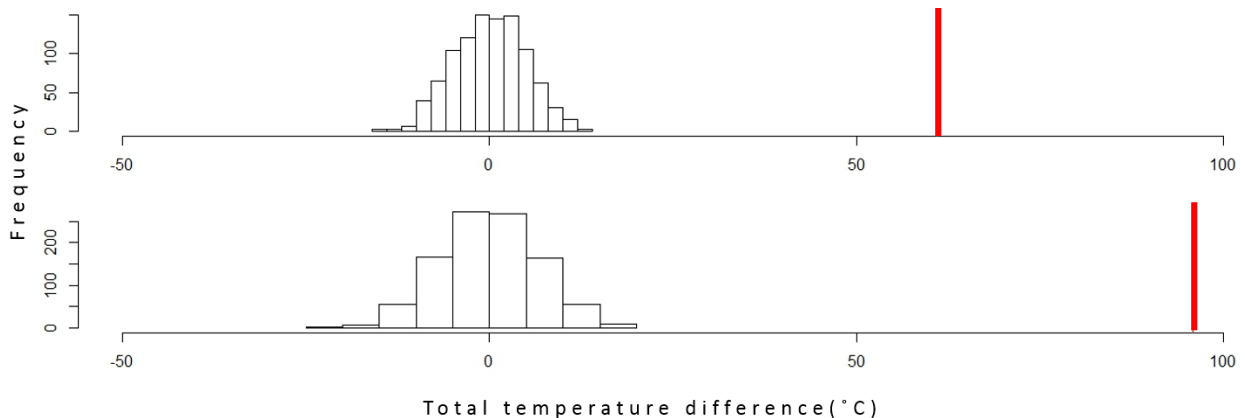

Figure 17: Monte Carlo analyses of un-shaded sand and un-shaded nest pair comparisons. Histograms representing each of two randomizations of temperature difference calculations (1,000 iterations). Red lines represent the total observed temperature difference for each pair of treatments. Lines to the right of the histograms indicate un-shaded nest was significantly warmer than un-shaded sand (2/2).

The sand moisture experiment had a marginal treatment effect ($p=0.065$), with un-shaded treatments having slightly increased cumulative moisture (Figure 18), see Figure 19 for a plot of the mean sand moisture over the sample period.

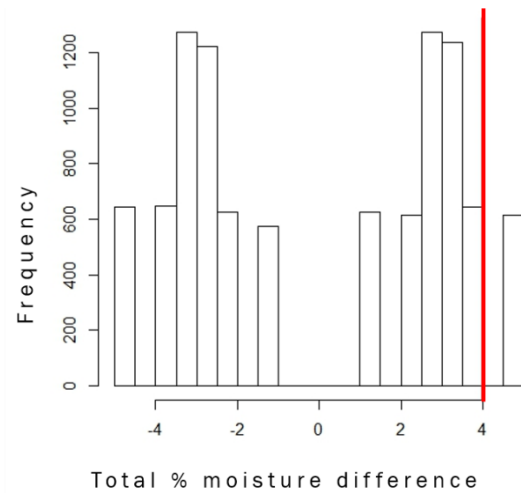

Figure 18: Histogram representing 10,000 randomizations of moisture difference calculations. The red line represents total observed moisture difference (3.975%) with marginal treatment effect ($p=0.065$).

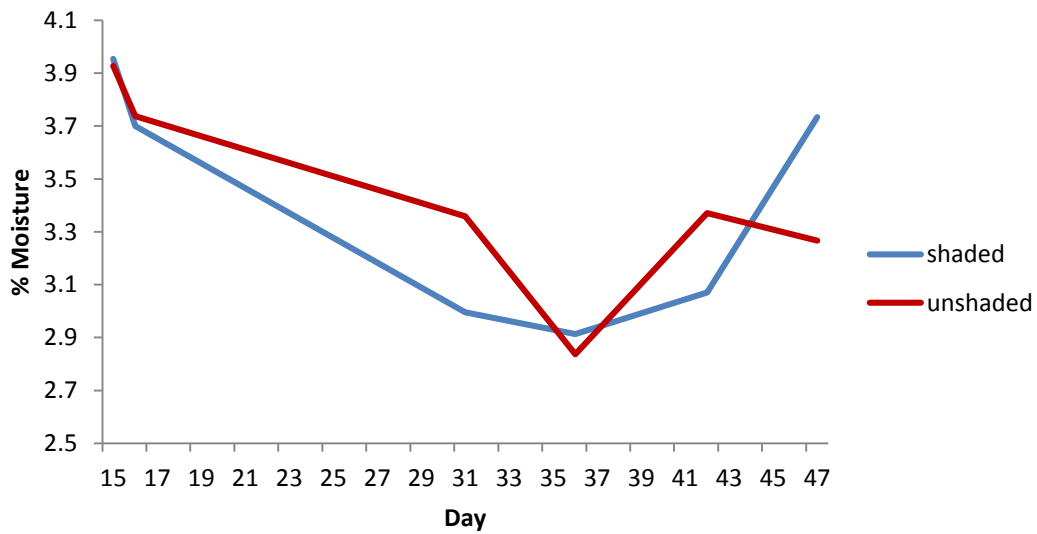

Figure 19: Mean percent sand moisture by day comparing shaded and un-shaded sand treatments.

Justification for Shade Application Study

The differences in mean temperature recorded during the middle third of incubation between the shaded and un-shaded sand were used to determine that the shade structure would likely reduce the sand temperature surrounding a nest, possibly enough to impact sex ratio, depending on the portion of the season in which the treatment is deployed. The shade structure did not result in extreme temperature reduction or significantly higher mean temperatures, therefore the technique was tested during the following nesting season.

Although the temperature comparison between un-shaded sand and un-shaded nest treatments did show a statistically significant temperature difference, however a sample size of two was not adequate to predict the impact of metabolic heating during the themosensitive period for the shade application study. However a prior study shows that the majority of metabolic heating in loggerhead nests occurs during the final third of incubation, following the sex determining period (Zbinden et al. 2006); metabolic heating has also been observed during the final two thirds of incubation (van de Merwe et al. 2006).

The mean moisture content of sand samples from shaded and un-shaded treatments both varied in a comparable manner across the sample period (Figure 19), and this was likely due to environmental effects that impacted both treatments similarly. Although there may be concern that the shade cloth might act as barrier to rainfall, a difference between shaded and un-shaded treatments across the time period was not detected, therefore it may be inferred that the shade structure did not significantly impact sand moisture in comparison to the un-shaded treatment. However, sand samples to determine final sand moisture were taken in the shade application study to further validate this inference.

APPENDIX C: NEST SHADING MONTE CARLO ANALYSES

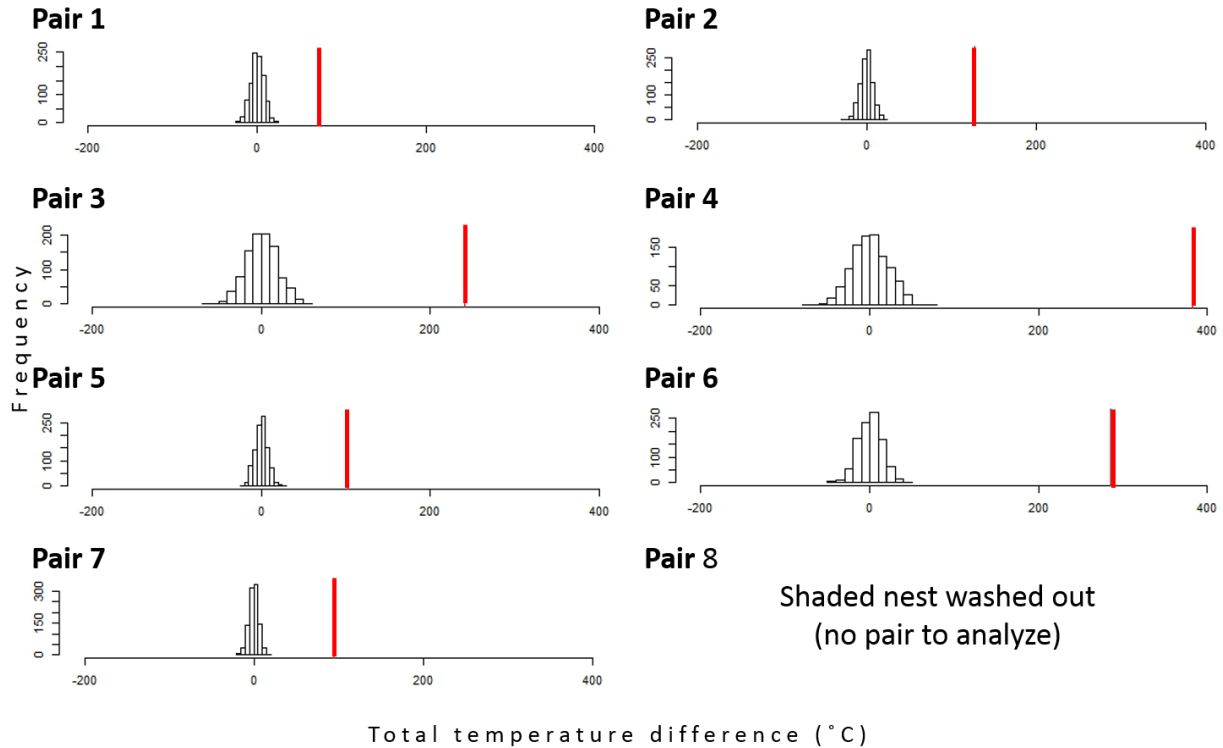

Figure 20: Monte Carlo analyses of shaded nest and un-shaded sand nest comparisons (pairs 1-7). Each histogram represents the randomizations of temperature difference calculations. Red lines represent the total observed temperature difference for each pair of treatments. Lines to the right of the histograms indicate shaded sand was significantly cooler.

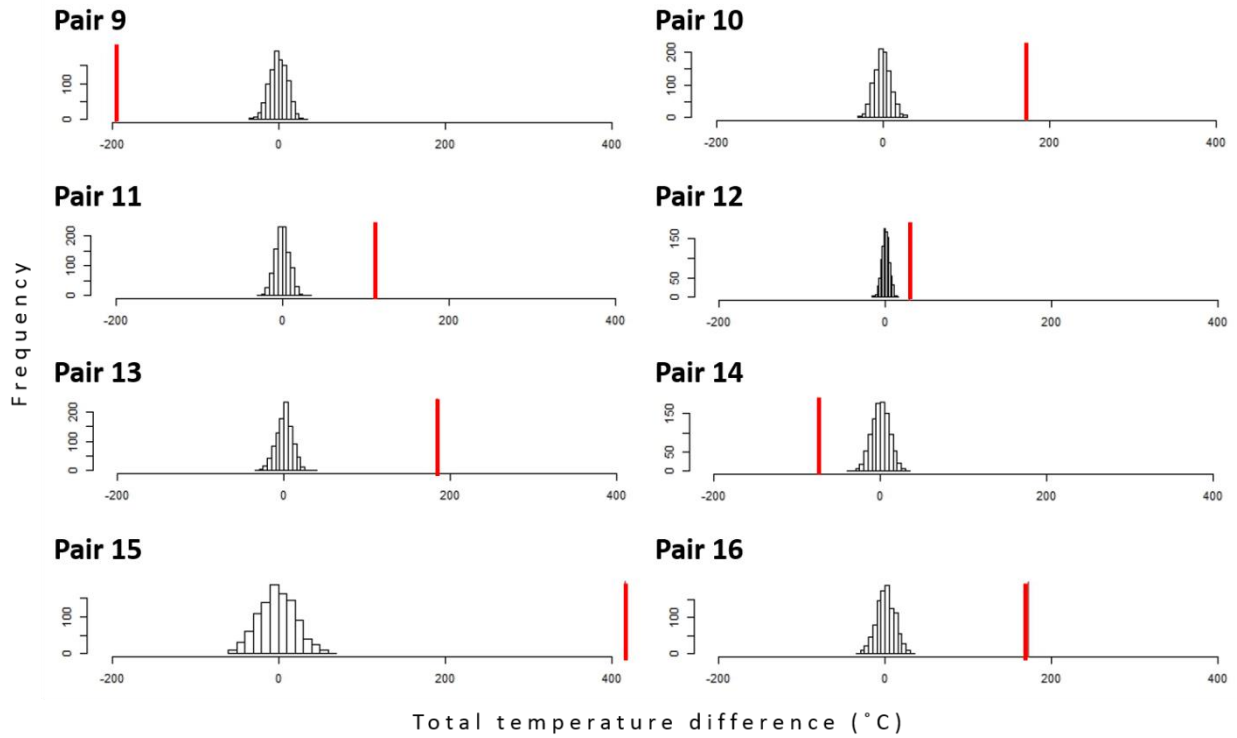

Figure 21: Monte Carlo analyses of shaded nest and un-shaded sand nest comparisons (pairs 9-16). Histograms represent the randomizations of temperature difference calculations. Red lines represent the total observed temperature difference for each pair of treatments. Lines to the right of the histograms indicate shaded sand was significantly cooler, lines to the left of the histogram indicate shaded sand was significantly warmer.

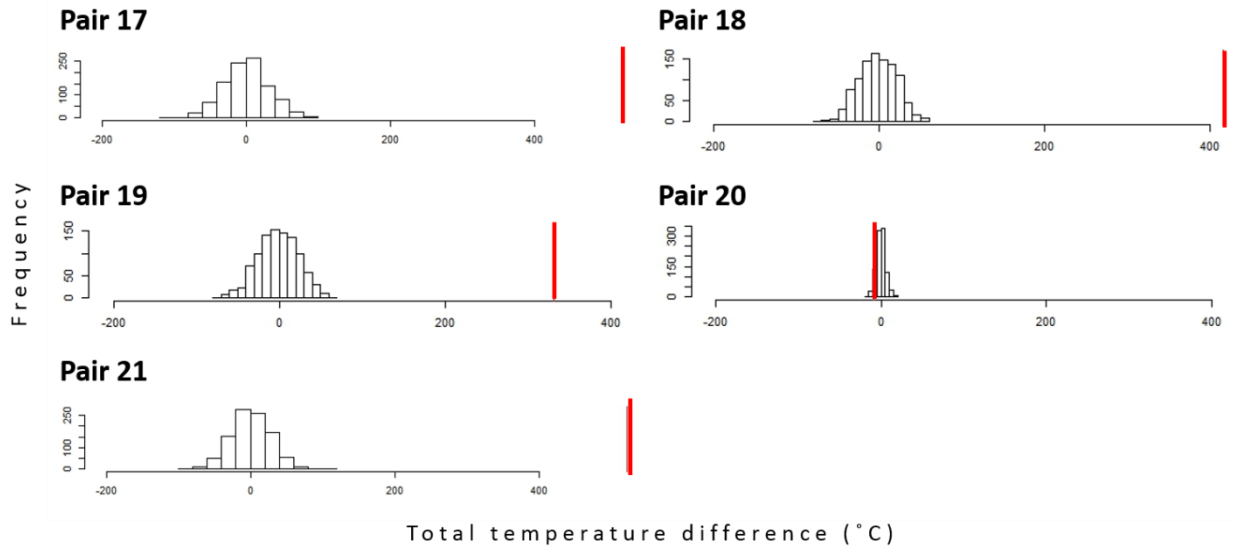

Figure 22: Monte Carlo analyses of shaded nest and un-shaded sand nest comparisons (pairs 17-21). Histogram represent the randomizations of temperature difference calculations. Red lines represent the total observed temperature difference for each pair of treatments. Lines to the right of the histograms indicate shaded sand was significantly cooler and the line within the histogram represents a marginal treatment effect ($p=0.055$).

**APPENDIX D: COMPARISON OF MIDDLE THIRD HOURLY
TEMPERATURE READINGS FOR NEST PAIRS**

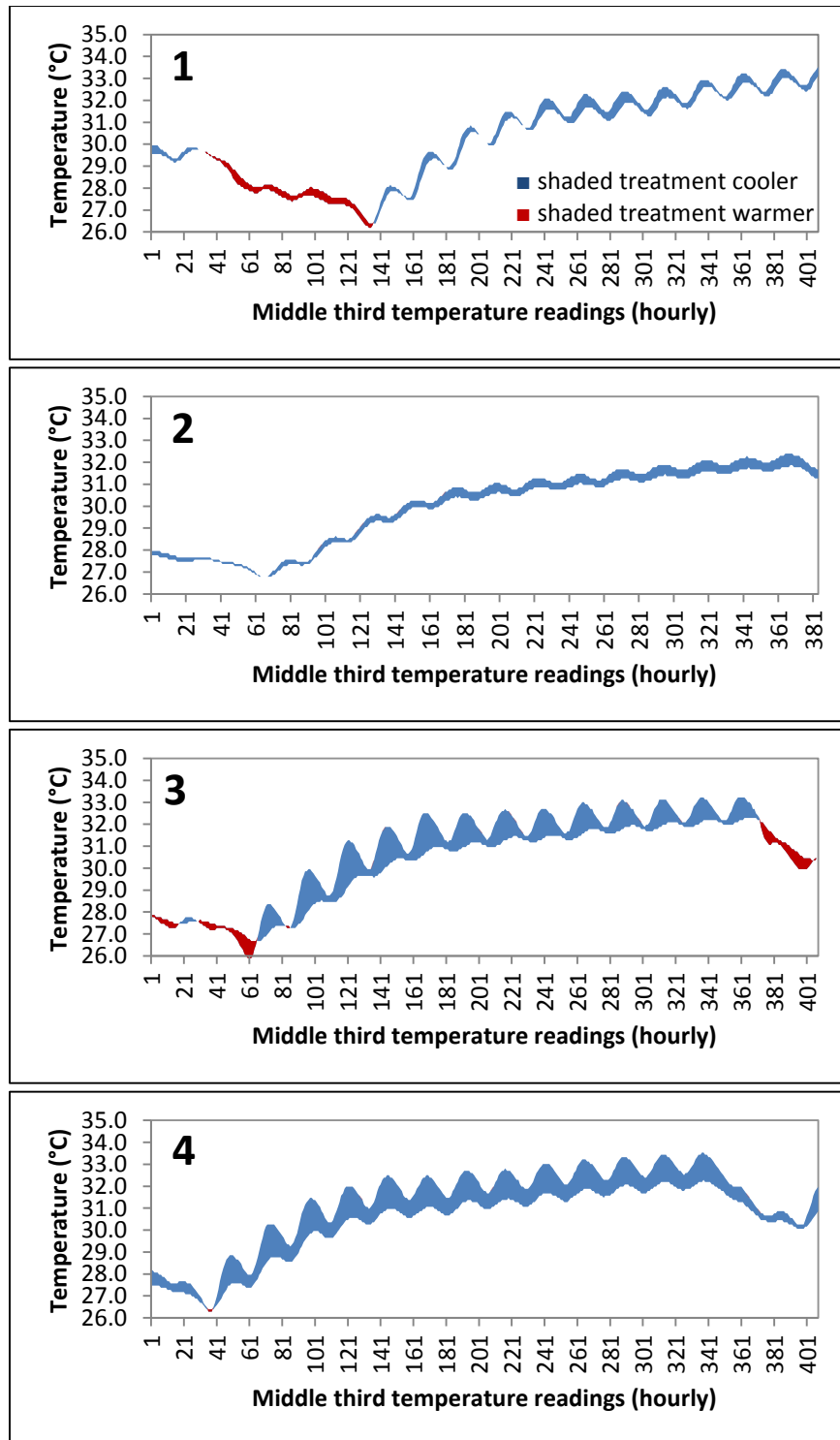

Figure 23: A comparison of hourly temperature readings for nest pairs 1-4 over the course of the middle third of incubation.

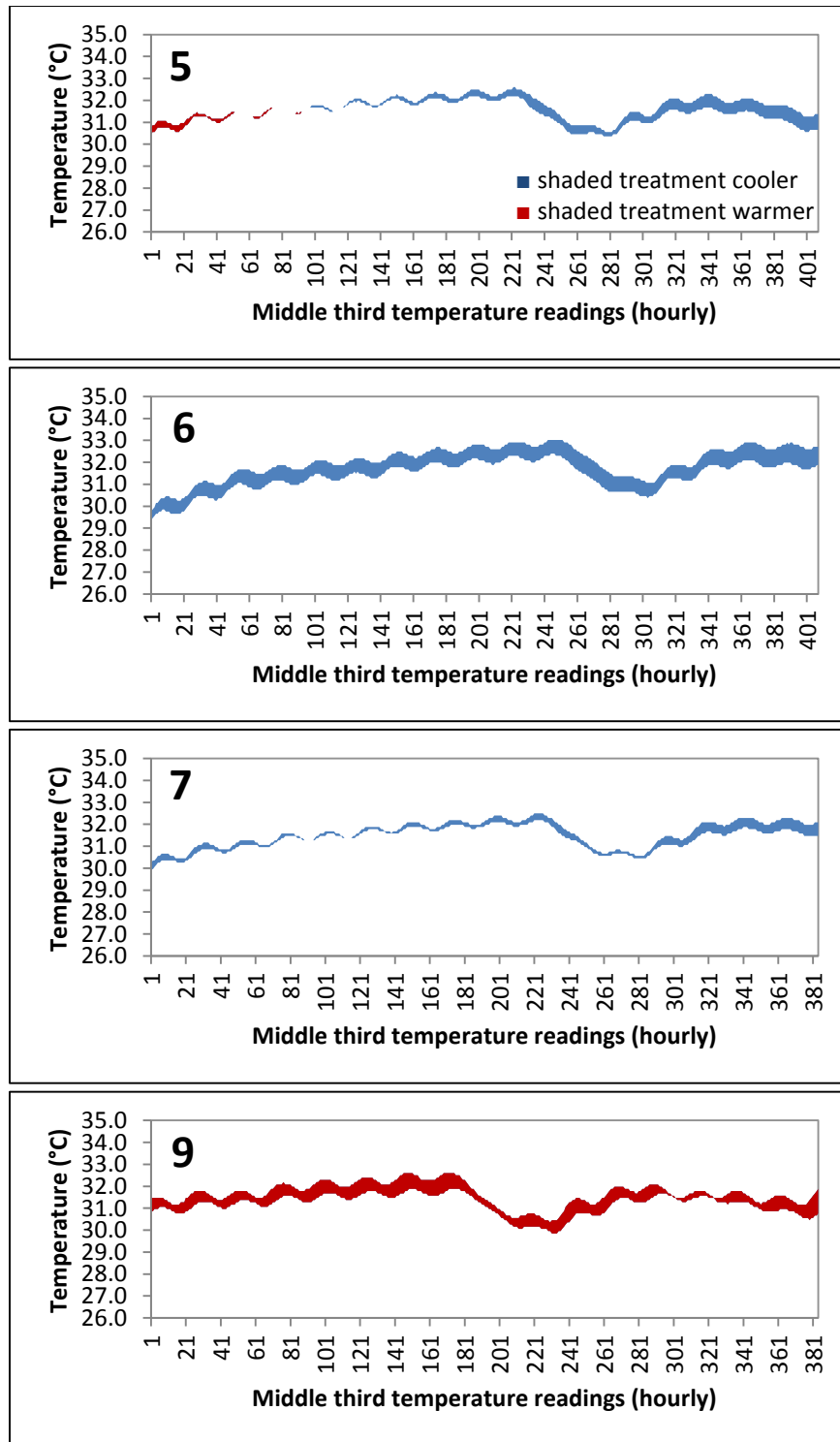

Figure 24: A comparison of hourly temperature readings for nest pairs 5, 6, and 8 over the course of the middle third of incubation.

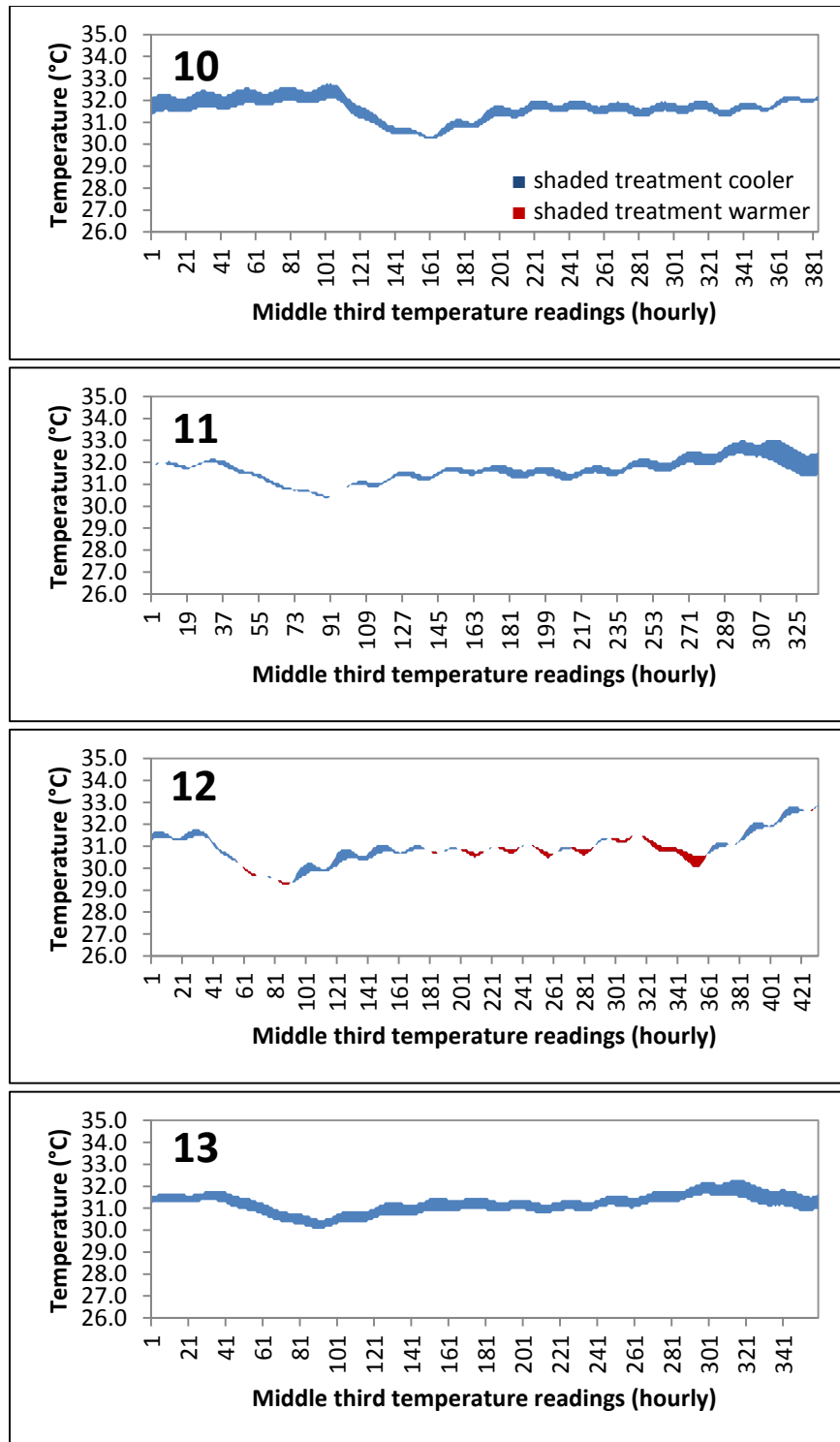

Figure 25: A comparison of hourly temperature readings for nest pairs 10-13 over the course of the middle third of incubation.

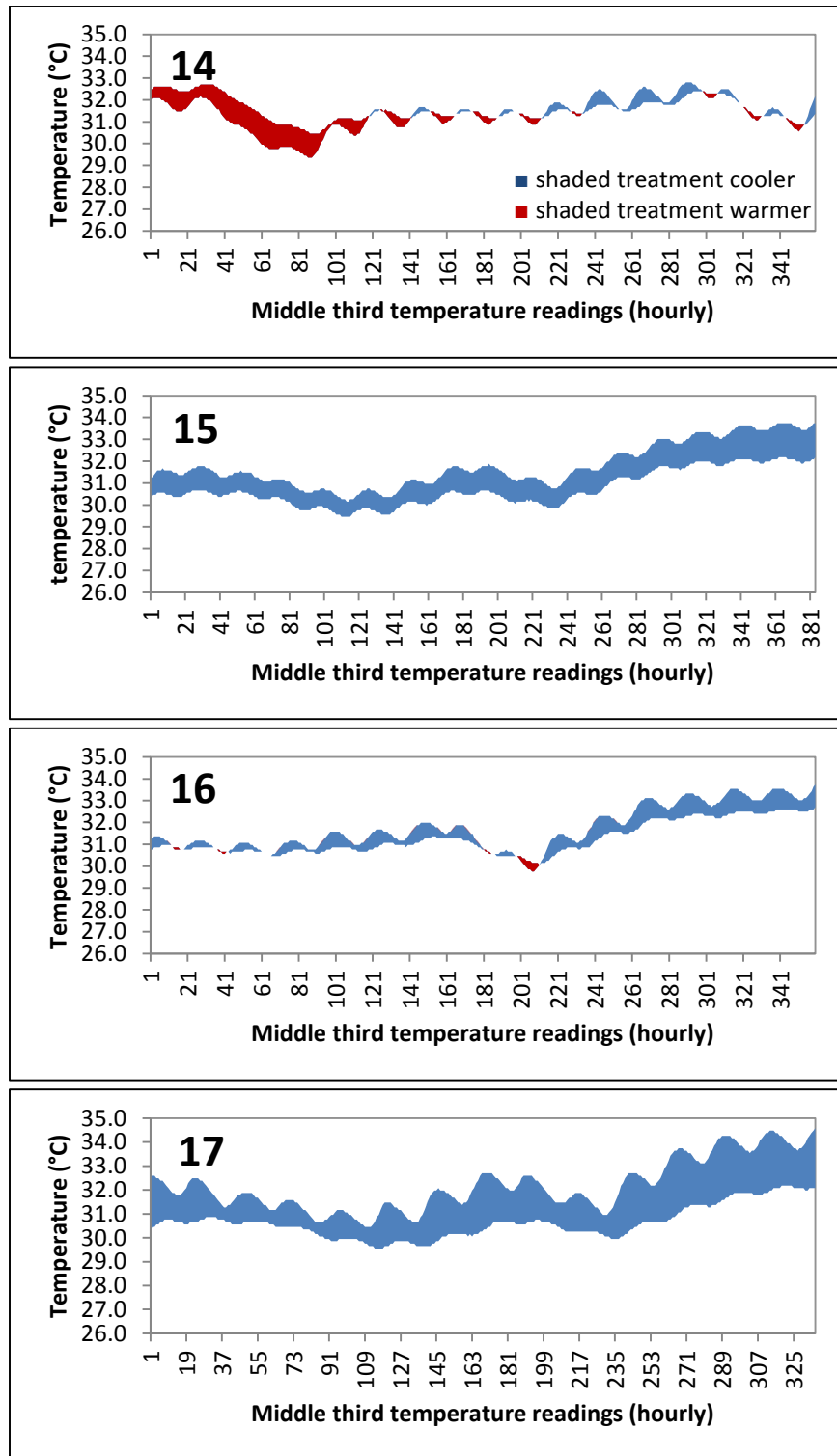

Figure 26: A comparison of hourly temperature readings for nest pairs 14-17 over the course of the middle third of incubation.

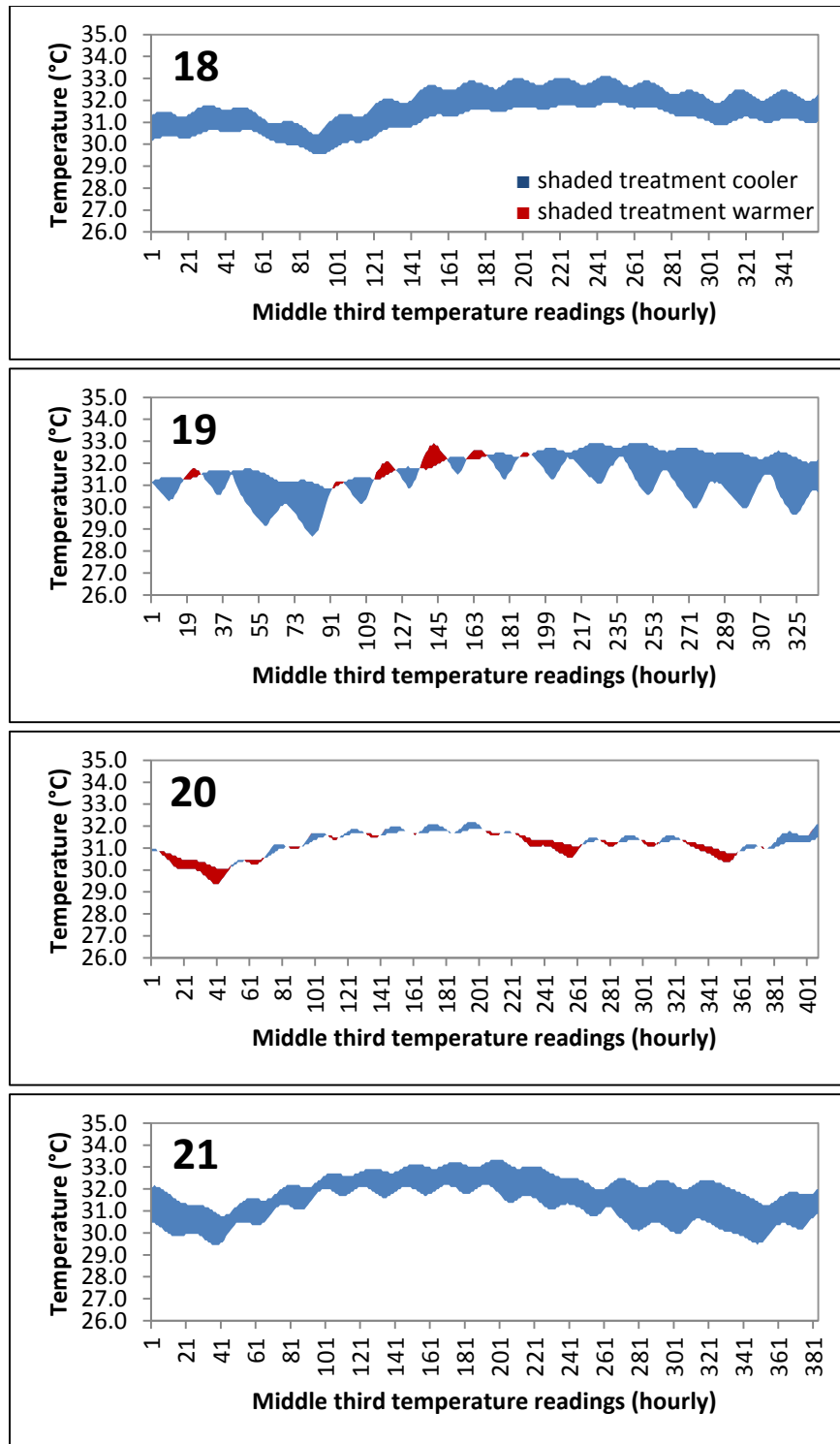

Figure 27: A comparison of hourly temperature readings for nest pairs 18-21 over the course of the middle third of incubation.

REFERENCES

- Addison, D.S. (1997). Galvanized Wire Cages Can Prevent Nest Depredation. *Marine Turtle Newsletter*, 76, 8–11.
- Addison, D.S. & Henricy, S. (1994). *A comparison of galvanized wire mesh cages vs. flat chain-link screen in preventing Procyon lotor depredation of Caretta caretta nests.*
- Antworth, R.L., Pike, D.A. & Stiner, J.C. (2006). Nesting ecology, current status, and conservation of sea turtles on an uninhabited beach in Florida, USA. *Biological Conservation*, 130, 10–15.
- Beggs, J.A., Horrocks, J.A. & Krueger, B.H. (2007). *Increase in hawksbill sea turtle Eretmochelys imbricata nesting in Barbados, West Indies.*
- Bjorndal, K.A. & Jackson, J.B.C. (2002). Roles of Sea Turtles in Marine Ecosystems: Reconstructing the Past. In: *The Biology of Sea Turtles* (eds. Lutz, P.L., Musick, J.A. & Wyneken, J.). CRC Press, pp. 259–272.
- Blair, K. (2005). *Determination of sex ratios and their relationship to nest temperature of loggerhead sea turtle (Caretta caretta, L) hatchlings produced along the southeastern Atlantic coast of the United States.*
- Bull, J.J. & Charnov, E.L. (1989). Enigmatic Reptilian Sex Ratios. *Evolution*, 43, 1561.
- Deutsch, C.A., Tewksbury, J.J., Huey, R.B., Sheldon, K.S., Ghalambor, C.K., Haak, D.C. & Martin, P.R. (2008). Impacts of climate warming on terrestrial ectotherms across latitude. *PNAS*, 105, 6668–6672.
- ESRI. (2009). *ArcGIS Desktop 9.3.1*. Environmental Systems Resource Institute, Redlands, CA.

- Fish, M.R., Côté, I.M., Horrocks, J.A., Mulligan, B., Watkinson, A.R. & Jones, A.P. (2008). Construction setback regulations and sea-level rise: Mitigating sea turtle nesting beach loss. *Ocean & Coastal Management*, 51, 330–341.
- Fisher, R.A. (1930). *The Genetical Theory of Natural Selection*. Clarendon Press, Oxford.
- Foley, A.M., Peck, S.A. & Harman, G.R. (2006). Effects of Sand Characteristics and Inundation on the Hatching Success of Loggerhead Sea Turtle (*Caretta caretta*) Clutches on Low-Relief Mangrove Islands in Southwest Florida. *Chelonian Conservation and Biology*, 5, 32.
- Fuentes, M., Maynard, J., Guinea, M., Bell, I., Werdell, P. & Hamann, M. (2009). Proxy indicators of sand temperature help project impacts of global warming on sea turtles in northern Australia. *Endangered Species Research*, 9, 33–40.
- Fuentes, M.M.P.B., Limpus, C.J. & Hamann, M. (2011). Vulnerability of sea turtle nesting grounds to climate change. *Global Change Biology*, 17, 140–153.
- Fuentes, M.M.P.B. & Porter, W.P. (2013). Using a microclimate model to evaluate impacts of climate change on sea turtles. *Ecological Modelling*, 251, 150–157.
- FWC. (2007). *Marine Turtle Conservation Guidelines*. Florida Fish and Wildlife Conservation Commission, Tallahassee, FL.
- Georges, A., Limpus, C. & Stoutjesdijk, R. (1994). Hatchling sex in the marine turtle *Caretta caretta* is determined by proportion of development at a temperature, not daily duration of exposure. *Journal of Experimental Zoology*, 270, 432–444.
- Girondot, M. & Pieau, C. (1999). A fifth hypothesis for the evolution of TSD in reptiles. *Trends in Ecology & Evolution*, 14, 359–360.

- Gordo, O. & Doi, H. (2012). Spring phenology delays in an insular subtropical songbird: is response to climate change constrained by population size? *J Ornithol*, 153, 355–366.
- Gotelli, N.J. & Ellison, A.M. (2004). *A Primer of Ecological Statistics*. Sinauer Associates, Incorporated Publishers.
- Hanson, J., Wibbels, T. & Martin, R.E. (1998). Predicted female bias in sex ratios of hatchling loggerhead sea turtles from a Florida nesting beach. *Can. J. Zool.*, 76, 1850–1861.
- Hawkes, L.A., Broderick, A.C., Godfrey, M.H. & Godley, B.J. (2007). Investigating the potential impacts of climate change on a marine turtle population. *Global Change Biology*, 13, 923–932.
- Hawkes, L.A., Broderick, A.C., Godfrey, M.H. & Godley, B.J. (2009). REVIEW Climate change and marine turtles. *Endang Species Res*, 7, 137–154.
- Hays, G.C., Fossette, S., Katselidis, K.A., Schofield, G. & Gravenor, M.B. (2010). Breeding periodicity for male sea turtles, operational sex ratios, and implications in the face of climate change. *Conserv. Biol.*, 24, 1636–1643.
- Hillis-Starr, Z. & Phillips, B. (2002). Buck Island Sea Turtle Research Program: Sea Turtle Nesting Research and Monitoring Program Protocol Manual.
- Hoegh-Guldberg, O. (1999). Climate change, coral bleaching and the future of the world's coral reefs. *Mar. Freshwater Res.*, 50, 839–866.
- Von Holle, B., Wei, Y. & Nickerson, D. (2010). Climatic Variability Leads to Later Seasonal Flowering of Floridian Plants. *PLoS One*, 5.
- IPCC. (2007). *Climate Change 2007: The Physical Science Basis. Contribution of Working Group I to the Fourth Assessment Report of the Intergovernmental Panel on Climate Change*

- [Solomon, S., D. Qin, M. Manning, Z. Chen, M. Marquis, K.B. Avery, M.Tignor and H.L. Miller (eds.)]. Cambridge University Press, Cambridge, United Kingdom and New York, NY, USA.
- Jackson, J.B.C. (1997). Reefs since Columbus. *Coral Reefs*, 16, S23–S32.
- Janzen, F.J. (1994). Climate change and temperature-dependent sex determination in reptiles. *PNAS*, 91, 7487–7490.
- Janzen, F.J. & Paukstis, G.L. (1991). Environmental Sex Determination in Reptiles: Ecology, Evolution, and Experimental Design. *The Quarterly Review of Biology*, 66, 149.
- Jourdan, J. & Fuentes, M.M.P.B. (2013). Effectiveness of strategies at reducing sand temperature to mitigate potential impacts from changes in environmental temperature on sea turtle reproductive output. *Mitig Adapt Strateg Glob Change*, 1–13.
- Keller, R., Ackerman, J., Carter, C. & Stiner, J.C. (2008). *2008 Marine Turtle Nesting Summary, Canaveral National Seashore*.
- LeBlanc, A.M. & Wibbels, T. (2009). Effect of daily water treatment on hatchling sex ratios in a turtle with temperature-dependent sex determination. *Journal of Experimental Zoology Part A: Ecological Genetics and Physiology*, 311A, 68–72.
- Manly, B.F.J. (1991). *Randomization and Monte Carlo Methods in Biology*. CRC Press.
- Mayor, P.A., Phillips, B. & Hillis-Starr, Z.M. (1996). *Results of the stomach content analysis of the juvenile hawksbill turtles of Buck Island Reef National Monument, USVI* (Preliminary research report).
- Mazaris, A.D., Kallimanis, A.S., Tzanopoulos, J., Sgardelis, S.P. & Pantis, J.D. (2009). Sea surface temperature variations in core foraging grounds drive nesting trends and phenology of

- loggerhead turtles in the Mediterranean Sea. *Journal of Experimental Marine Biology and Ecology*, 379, 23–27.
- Van de Merwe, J., Ibrahim, K. & Whittier, J. (2006). Effects of Nest Depth, Shading, and Metabolic Heating on Nest Temperatures in Sea Turtle Hatcheries. *Chelonian Conservation and Biology*, 5, 210–215.
- Meylan, A.B. (1999). Status of the Hawksbill Turtle (*Eretmochelys imbricata*) in the Caribbean Region. *Chelonian Conservation and Biology*, 3, 177–184.
- Meylan, A.B. & Donnelly, M. (1999). Status justification for listing the hawksbill turtle (*Eretmochelys imbricata*) as critically endangered on the 1996 IUCN Red List of Threatened Animals. *Chelonian Conservation and Biology*, 3, 200–224.
- Mitchell, N.J. & Janzen, F.J. (2010). Temperature-Dependent Sex Determination and Contemporary Climate Change. *Sexual Development*, 4, 129–140.
- Del Monte-Luna, P., Guzmán-Hernández, V., Cuevas, E.A., Arreguín-Sánchez, F. & Lluch-Belda, D. (2012). Effect of North Atlantic climate variability on hawksbill turtles in the Southern Gulf of Mexico. *Journal of Experimental Marine Biology and Ecology*, 412, 103–109.
- Mrosovsky, N. (1988). Pivotal temperatures for loggerhead turtles (*Caretta caretta*) from northern and southern nesting beaches. *Canadian Journal of Zoology*, 66, 661–669.
- Mrosovsky, N. (1994). Sex ratios of sea turtles. *The Journal of experimental zoology*, 270, 16–27.
- Mrosovsky, N. & Godfrey, M.H. (2010). Editorial: Thoughts on Climate Change and Sex Ratio of Sea Turtles. *MTN*, 128, 7–11.

- Mrosovsky, N., Kamel, S., Rees, A.F., Bay, M.D. & Greece. (2002). Pivotal temperature for loggerhead turtles (*Caretta caretta*) from Kyparissia. *Canadian Journal of Zoology*, 80, 2118–2124.
- Mrosovsky, N., Lavin, C. & Godfrey, M.H. (1995). Thermal effects of condominiums on a turtle beach in Florida. *Biological Conservation*, 74, 151–156.
- Mrosovsky, N. & Pieau, C. (1991). Transitional range of temperature, pivotal temperatures and thermosensitive stages for sex determination in reptiles. *Amphibia-Reptilia*, 12, 169–179.
- Mrosovsky, N. & Provancha, J. (1992). Sex ratio of hatchling loggerhead sea turtles: data and estimates from a 5-year study. *Can. J. Zool.*, 70, 530–538.
- Naro-Maciel, E., Mrosovsky, N. & Marcovaldi, M.A. (1999). Thermal profiles of sea turtle hatcheries and nesting areas at Praia do Forte, Brazil. *Chelonian Conservation and Biology*, 3, 407–413.
- Neuwald, J.L. & Valenzuela, N. (2011). The Lesser Known Challenge of Climate Change: Thermal Variance and Sex-Reversal in Vertebrates with Temperature-Dependent Sex Determination. *PLoS One*, 6.
- NMFS & USFWS. (2013). *Hawksbill sea turtle (Eretmochelys imbricata): 5-year review: summary and evaluation*. National Marine Fisheries Service and U.S. Fish and Wildlife Service, Silver Spring, MD and Jacksonville, FL.
- Parmesan, C. (2006). Ecological and Evolutionary Responses to Recent Climate Change. *Annual Review of Ecology, Evolution, and Systematics*, 37, 637–669.
- Parmesan, C. & Yohe, G. (2003). A globally coherent fingerprint of climate change impacts across natural systems. *Nature*, 421, 37–42.

- Patino-Martinez, J., Marco, A., Quiñones, L. & Hawkes, L. (2012). A potential tool to mitigate the impacts of climate change to the caribbean leatherback sea turtle. *Global Change Biology*, 18, 401–411.
- Pemberton, R.A.J. (2000). *The Habitat Utilization of Juvenile Hawksbill Sea Turtles (Eretmochelys Imbricata) at Buck Island Reef National Monument St. Croix, U.S. Virgin Islands*.
- Pike, D.A. (2009). Do Green Turtles Modify Their Nesting Seasons in Response to Environmental Temperatures? *Chelonian Conservation and Biology*, 8, 43–47.
- Pike, D.A., Antworth, R.L. & Stiner, J.C. (2006). Earlier Nesting Contributes to Shorter Nesting Seasons for the Loggerhead Seaturtle, *Caretta caretta*. *Journal of Herpetology*, 40, 91–94.
- Pike, D.A. & Stiner, J.C. (2007). Sea Turtle Species Vary in Their Susceptibility to Tropical Cyclones. *Oecologia*, 153, 471–478.
- PO.DAAC. (2012). Physical Oceanography Distributed Active Archive Center Ocean ESIP Tool (POET) [WWW Document]. *NASA Jet Propulsion Laboratory: California Institute of Technology*. URL <http://poet.jpl.nasa.gov/>
- Poloczanska, E.S., Limpus, C.J. & Hays, G.C. (2009). Chapter 2 Vulnerability of Marine Turtles to Climate Change. In: *Advances in Marine Biology*, Advances in Marine Biology (ed. David W. Sims). Academic Press, pp. 151–211.
- Primack, R.B., Ibáñez, I., Higuchi, H., Lee, S.D., Miller-Rushing, A.J., Wilson, A.M. & Silander Jr., J.A. (2009). Spatial and interspecific variability in phenological responses to warming temperatures. *Biological Conservation*, 142, 2569–2577.

- Przeslawski, R., Ahyong, S., Byrne, M., Wörheide, G. & Hutchings, P. (2008). Beyond corals and fish: the effects of climate change on noncoral benthic invertebrates of tropical reefs. *Global Change Biology*, 14, 2773–2795.
- R Core Team. (2013). *R: A Language and Environment for Statistical Computing*. R Foundation for Statistical Computing, Vienna, Austria.
- Reynolds, R.W., Smith, T.M., Liu, C., Chelton, D.B., Casey, K.S. & Schlax, M.G. (2007). Daily High-Resolution-Blended Analyses for Sea Surface Temperature. *Journal of Climate*, 20, 5473–5496.
- Richardson, J.I., Bell, R. & Richar, T.H. (1999). Population ecology and demographic implications drawn from an 11-year study of nesting hawksbill turtles, *Eretmochelysimbricata*, at Jumby Bay, Long Island, Antigua, West Indies. *Chelonian Conservation and Biology*, 3, 244–250.
- Rodgers, M. (2013). *Hatchling sex ratios and nest temperature-sex ratio response of three South Florida marine turtle species (Caretta caretta L., Chelona mydas L., and Dermochelys coriacea V.)* (Master's Thesis).
- Saba, V.S., Santidrián-Tomillo, P., Reina, R.D., Spotila, J.R., Musick, J.A., Evans, D.A. & Paladino, F.V. (2007). The effect of the El Niño Southern Oscillation on the reproductive frequency of eastern Pacific leatherback turtles: ENSO influences Pacific leatherback nesting rate. *Journal of Applied Ecology*, 44, 395–404.
- Saba, V.S., Stock, C.A., Spotila, J.R., Paladino, F.V. & Tomillo, P.S. (2012). Projected response of an endangered marine turtle population to climate change. *Nature Clim. Change*, 2, 814–820.

- Schmid, J.L., Addison, D.S., Donnelly, M.A., Shirley, M.A. & Wibbels, T. (2008). The Effect of Australian Pine (*Casuarina equisetifolia*) Removal on Loggerhead Sea Turtle (*Caretta caretta*) Incubation Temperatures on Keewaydin Island, Florida. *Journal of Coastal Research*, 214–220.
- Schofield, G., Hobson, V.J., Fossette, S., Lilley, M.K.S., Katselidis, K.A. & Hays, G.C. (2010). BIODIVERSITY RESEARCH: Fidelity to foraging sites, consistency of migration routes and habitat modulation of home range by sea turtles. *Diversity and Distributions*, 16, 840–853.
- Shine, R. (1999). Why is sex determined by nest temperature in many reptiles? *Trends in Ecology & Evolution*, 14, 186–189.
- Storch, S., Wilson, R., Hillis-Starr, Z. & Adelung, D. (2005). Cold-blooded divers: temperature-dependent dive performance in the wild hawksbill turtle *Eretmochelys imbricata*. *Marine Ecology Progress Series*, 293, 263–271.
- Thomas, C.D., Cameron, A., Green, R.E., Bakkenes, M., Beaumont, L.J., Collingham, Y.C., Erasmus, B.F.N., de Siqueira, M.F., Grainger, A., Hannah, L., Hughes, L., Huntley, B., van Jaarsveld, A.S., Midgley, G.F., Miles, L., Ortega-Huerta, M.A., Townsend Peterson, A., Phillips, O.L. & Williams, S.E. (2004). Extinction risk from climate change. *Nature*, 427, 145–148.
- Tiwari, M. & Bjorndal, K.A. (2000). Variation in Morphology and Reproduction in Loggerheads, *Caretta caretta*, Nesting in the United States, Brazil, and Greece. *Herpetologica*, 56, 343–356.

- Tuttle, J. & Rostal, D. (2010). Effects of Nest Relocation on Nest Temperature and Embryonic Development of Loggerhead Sea Turtles (*Caretta caretta*). *Chelonian Conservation and Biology*, 9, 1–7.
- Varo-Cruz, N., Hawkes, L.A., Cejudo, D., López, P., Coyne, M.S., Godley, B.J. & López-Jurado, L.F. (2013). Satellite tracking derived insights into migration and foraging strategies of male loggerhead turtles in the eastern Atlantic. *Journal of Experimental Marine Biology and Ecology*, 443, 134–140.
- Vicente, V.P. (1989). Regional Commercial Sponge Extinctions in the West Indies: Are Recent Climatic Changes Responsible? *Marine Ecology*, 10, 179–191.
- Walcott, J., Eckert, S. & Horrocks, J.A. (2012). Tracking hawksbill sea turtles (*Eretmochelys imbricata*) during inter-nesting intervals around Barbados. *Mar Biol*, 159, 927–938.
- Walther, G.-R., Post, E., Convey, P., Menzel, A., Parmesan, C., Beebee, T.J.C., Fromentin, J.-M., Hoegh-Guldberg, O. & Bairlein, F. (2002). Ecological responses to recent climate change. *Nature*, 416, 389–395.
- Warner, D.A. & Shine, R. (2008). The adaptive significance of temperature-dependent sex determination in a reptile. *Nature*, 451, 566–568.
- Weishampel, J.F., Bagley, D.A. & Ehrhart, L.M. (2004). Earlier nesting by loggerhead sea turtles following sea surface warming. *Global Change Biology*, 10, 1424–1427.
- Weishampel, J.F., Bagley, D.A., Ehrhart, L.M. & Weishampel, A.C. (2010). Nesting phenologies of two sympatric sea turtle species related to sea surface temperatures. *Endang Species Res*, 12, 41–47.

- Wibbels, T. (2003). Chapter 4: Critical Approaches to Sex Determination in Sea Turtles. In: *The Biology of Sea Turtles* (eds. Lutz, P.L., Musick, J.A. & Wyneken, J.). CRC Press, pp. 103–134.
- Wibbels, T. (2007). Chapter 9: Sex Determination and Sex Ratios in Ridley Turtles. In: *Biology and conservation of ridley sea turtles / edited by Pamela T. Plotkin* (ed. Plotkin, P.T.). Johns Hopkins University Press, Baltimore, MD, pp. 167–189.
- Wibbels, T., Hillis-Starr, Z.-M. & Phillips, B. (1999). Female-Biased Sex Ratios of Hatchling Hawksbill Sea Turtles from a Caribbean Nesting Beach. *Journal of Herpetology*, 33, 142.
- Winegardner, D.L. (1996). *An Introduction to Soils for Environmental Professionals*. CRC Press.
- Witherington, B., Kubilis, P., Brost, B. & Meylan, A. (2009). Decreasing annual nest counts in a globally important loggerhead sea turtle population. *Ecological Applications*, 19, 30–54.
- Witt, M.J., Hawkes, L.A., Godfrey, M.H., Godley, B.J. & Broderick, A.C. (2010). Predicting the impacts of climate change on a globally distributed species: the case of the loggerhead turtle. *J Exp Biol*, 213, 901–911.
- Witzell, W.N. (1983). *Synopsis of biological data on the hawksbill turtle, Eretmochelys imbricata (Linnaeus, 1766)*. Food and Agriculture Organization of the United Nations.
- Woody, K.K., Mayor, P.A., Hillis-Starr, Z.M. & Rodriguez, L. (2005). *Buck Island Reef Sea Turtle Research Program – Data Summery 2004*. National Park Service, U.S. Department of Interior, Christiansted, St. Croix, USVI.
- Wulff, J.L. (2006). Rapid diversity and abundance decline in a Caribbean coral reef sponge community. *Biological Conservation*, 127, 167–176.

- Wyneken, J., Epperly, S.P., Crowder, L.B., Vaughan, J. & Blair Esper, K. (2007). Determining sex in posthatchling loggerhead sea turtles using multiple gonadal and accessory duct characteristics. *Herpetologica*, 63, 19–30.
- Yntema, C.L. & Mrosovsky, N. (1982). Critical periods and pivotal temperatures for sexual differentiation in loggerhead sea turtles. *Can. J. Zool.*, 60, 1012–1016.
- Zbinden, J.A., Margaritoulis, D. & Arlettaz, R. (2006). Metabolic heating in Mediterranean loggerhead sea turtle clutches. *Journal of Experimental Marine Biology and Ecology*, 334, 151–157.