

STARS

University of Central Florida
STARS

UCF Patents

Technology Transfer

12-7-1999

Automatic Occupancy and Temperature Control for Ceiling Fan Operation

Danny Parker
University of Central Florida

Kendall Johnston
The Watt Stopper, Inc.

Find similar works at: <https://stars.library.ucf.edu/patents>
University of Central Florida Libraries <http://library.ucf.edu>

This Patent is brought to you for free and open access by the Technology Transfer at STARS. It has been accepted for inclusion in UCF Patents by an authorized administrator of STARS. For more information, please contact STARS@ucf.edu.

Recommended Citation

Parker, Danny and Johnston, Kendall, "Automatic Occupancy and Temperature Control for Ceiling Fan Operation" (1999). *UCF Patents*. 47.
<https://stars.library.ucf.edu/patents/47>





US005996898A

United States Patent [19]

[11] Patent Number: **5,996,898**

Parker et al.

[45] Date of Patent: **Dec. 7, 1999**

[54] **AUTOMATIC OCCUPANCY AND TEMPERATURE CONTROL FOR CEILING FAN OPERATION**

[75] Inventors: **Danny S. Parker**, Cocoa Beach, Fla.; **Kendall Ryan Johnston**, Santa Clara, Calif.

[73] Assignee: **University of Central Florida**, Orlando, Fla.

[21] Appl. No.: **09/067,236**

[22] Filed: **Apr. 27, 1998**

Related U.S. Application Data

[63] Continuation-in-part of application No. 09/056,428, Apr. 7, 1998.

[51] Int. Cl.⁶ **G05D 23/00**

[52] U.S. Cl. **236/51**; 454/229; 454/256

[58] Field of Search 454/229, 228, 454/256; 236/51

[56] References Cited

U.S. PATENT DOCUMENTS

4,322,632	3/1982	Hart	307/41
4,671,458	6/1987	Fukuda	236/49
4,716,409	12/1987	Hart	340/825
4,757,204	7/1988	Baldwin	250/342
4,787,722	11/1988	Claytor	350/452
4,849,737	7/1989	Kirihata	340/567
4,990,908	2/1991	Tung	340/825
5,033,113	7/1991	Wang	455/603
5,124,566	6/1992	Hu	307/116
5,187,472	2/1993	Hart	340/825.69

5,189,393	2/1993	Hu	340/322
5,372,545	12/1994	Noda et al.	454/256
5,406,173	4/1995	Mix	315/156
5,488,273	1/1996	Chang	318/16
5,511,943	4/1996	Chang	416/5
5,559,406	9/1996	Chang	315/322
5,627,527	5/1997	Mehta	340/825.06
5,637,040	6/1997	Kim	454/256

FOREIGN PATENT DOCUMENTS

401023045	1/1989	Japan	454/229
404098032	3/1992	Japan	454/229
405010562	1/1993	Japan	454/229
406002902	1/1994	Japan	454/229
406174274	6/1994	Japan	454/229
2260830	4/1993	United Kingdom	454/229

Primary Examiner—Henry Bennett
Assistant Examiner—Marc Norman
Attorney, Agent, or Firm—Law Offices of Brian S. Steinberger; Brian S. Steinberger

[57] ABSTRACT

Ceiling fan operation control for turning the fan on and off based on a passive infrared sensor, combined with a temperature sensor to regulate the speed of the fan. The passive infrared sensor, the temperature sensor and controls for both are in a housing directly mounted to the fan motor of the ceiling fan. The controls can be set screws covered by a removable cap. The passive infrared sensor can include a fresnel lens for sensing a 360 degree circumference beneath the fan, and a photo-optical sensor such as a photocell, which suspends ceiling fan control changes for allowing the fan to continue operation when the room is dark and occupants may be sleeping.

20 Claims, 9 Drawing Sheets

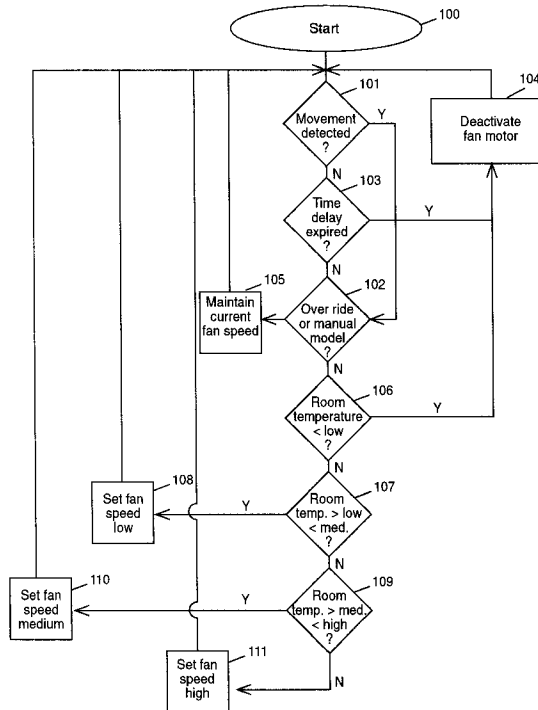

Fig. 1

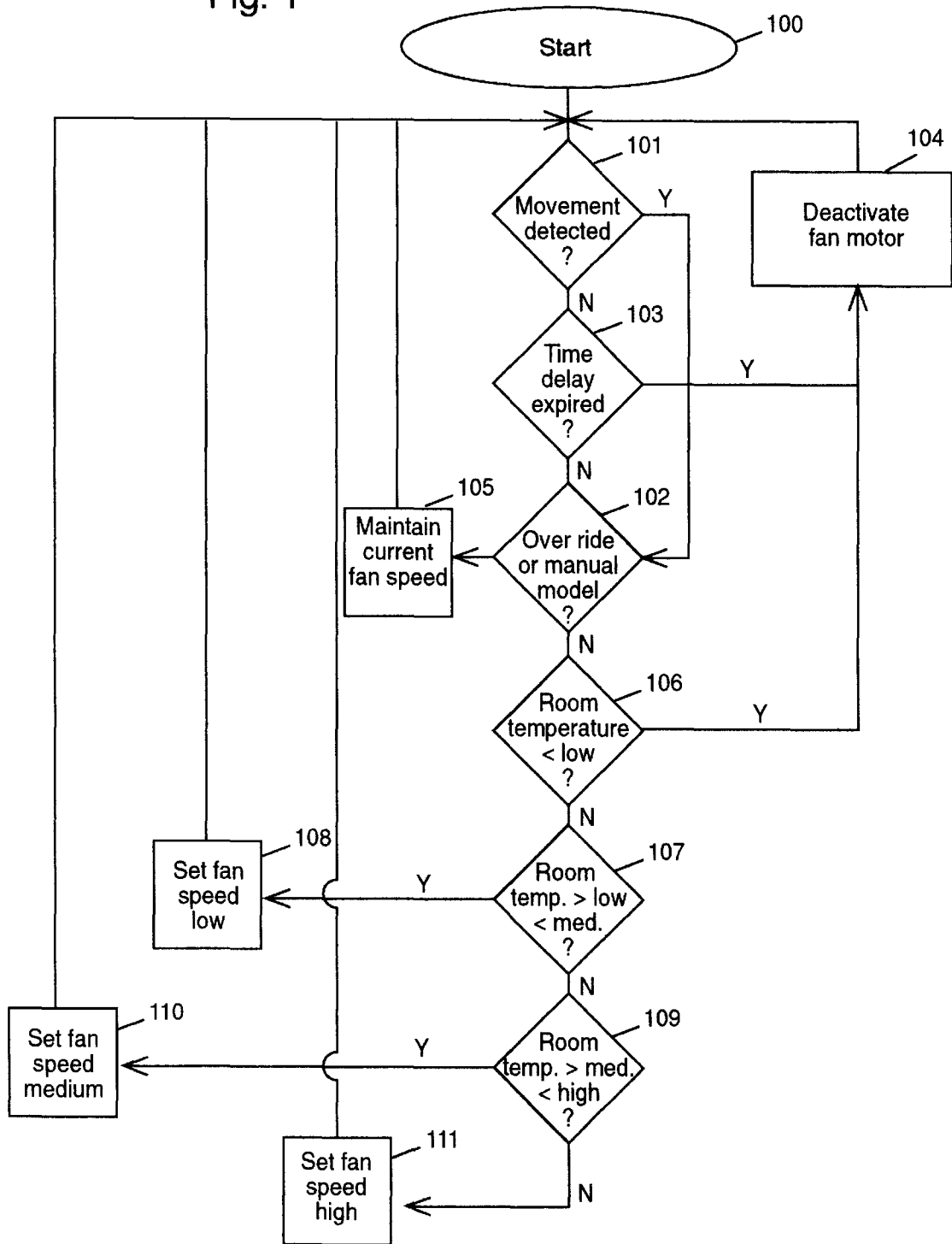
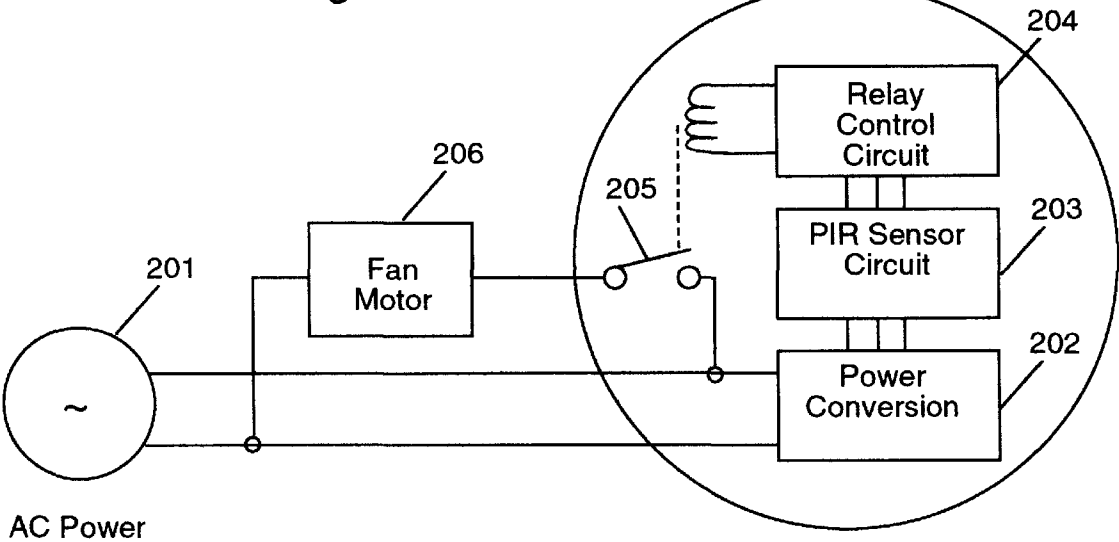

Fig. 2



Occupancy Ceiling Fan Control

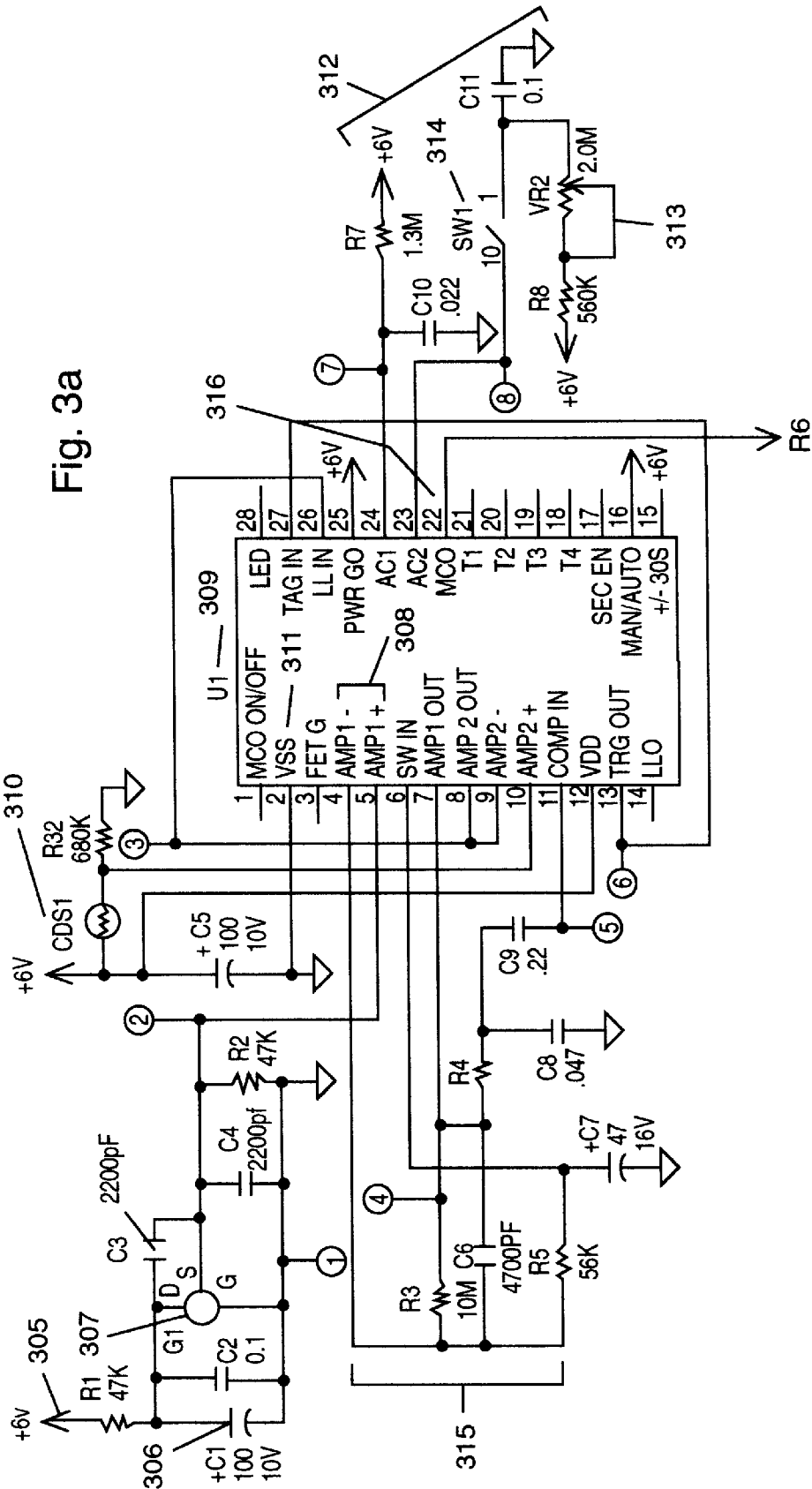

Fig. 3a

Fig. 3b

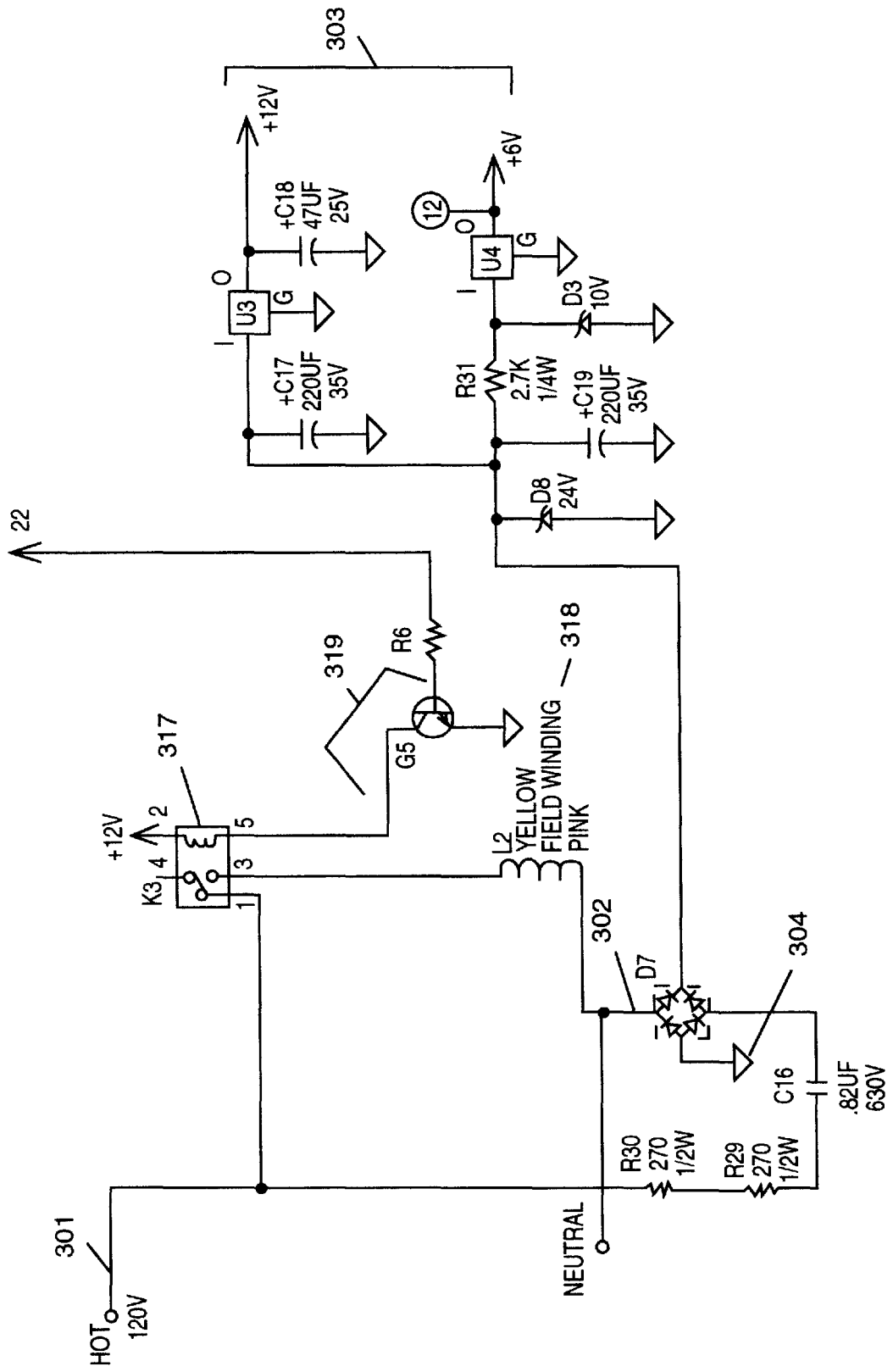
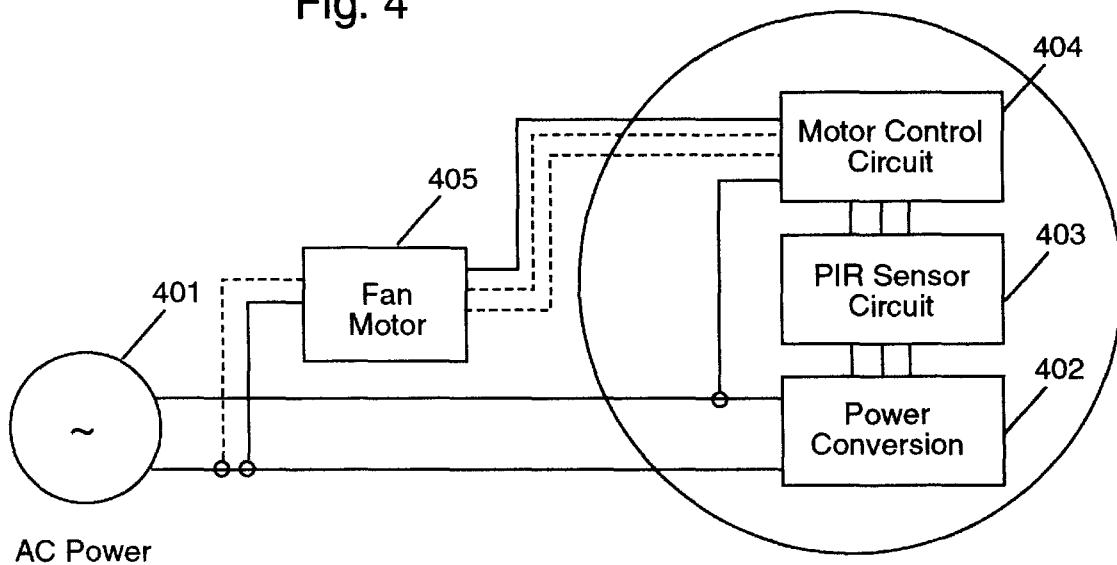

Fig. 4



Occupancy/Temperature Ceiling Fan Control

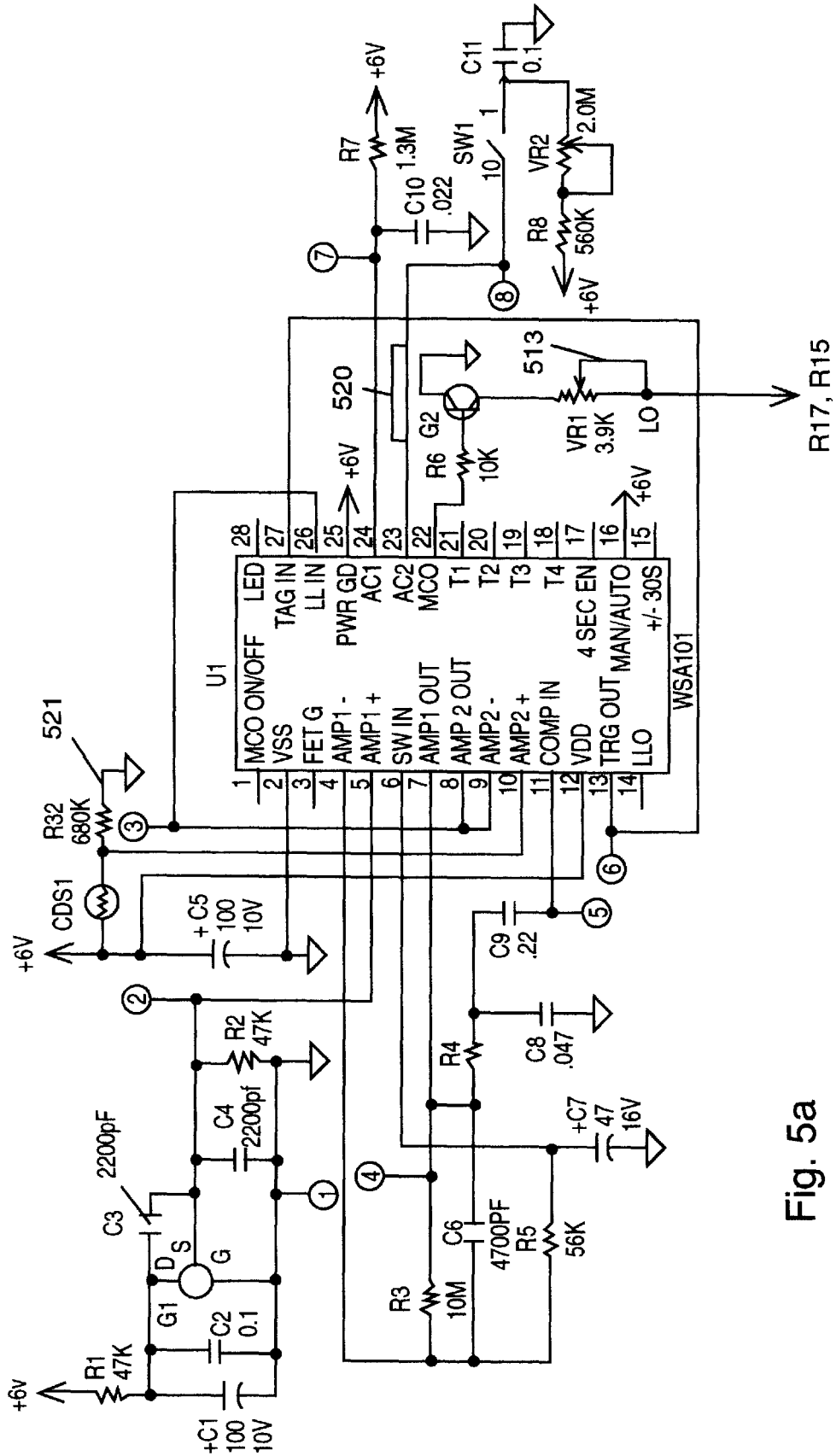

Fig. 5a

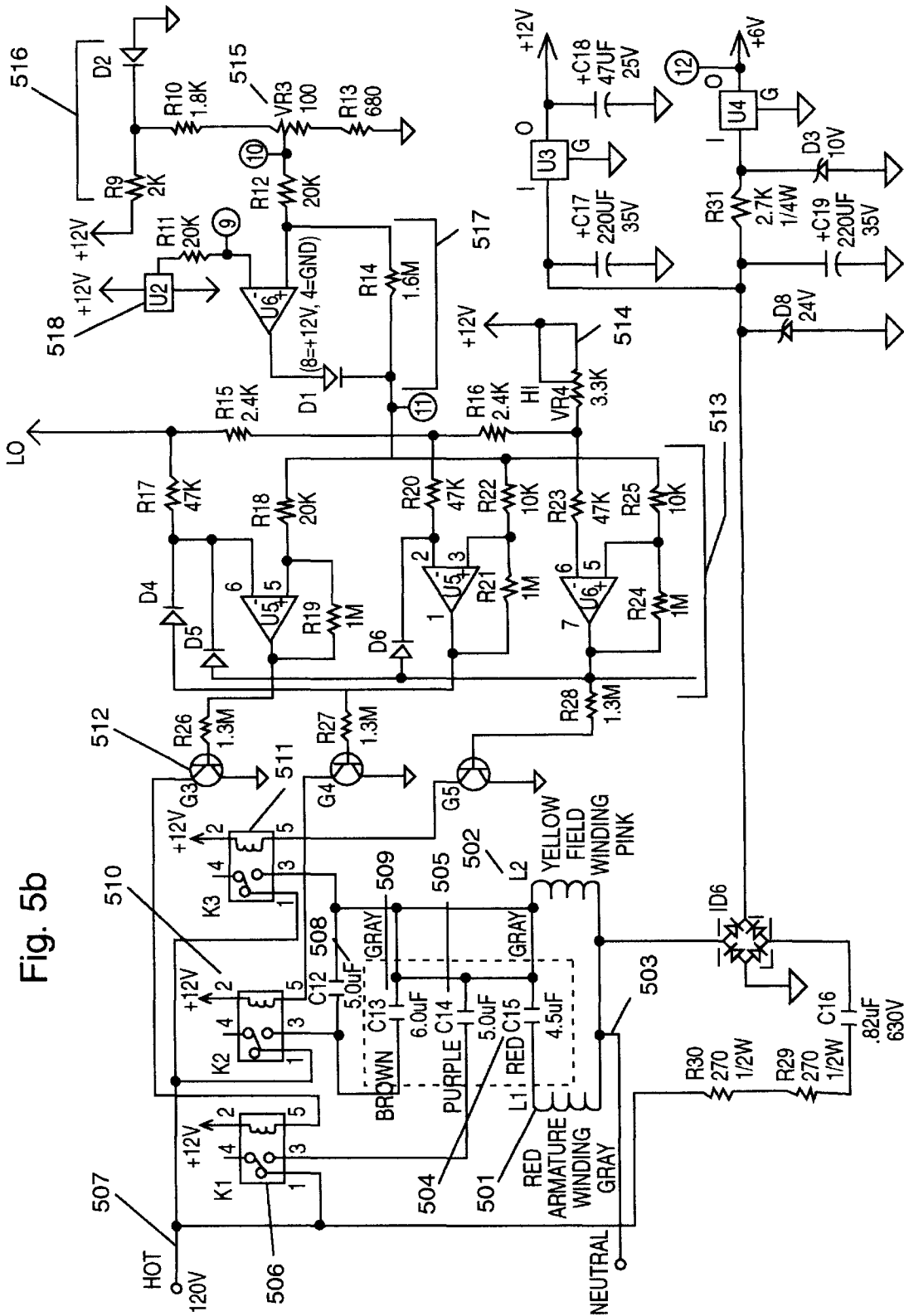

Fig. 5b

Fig. 6

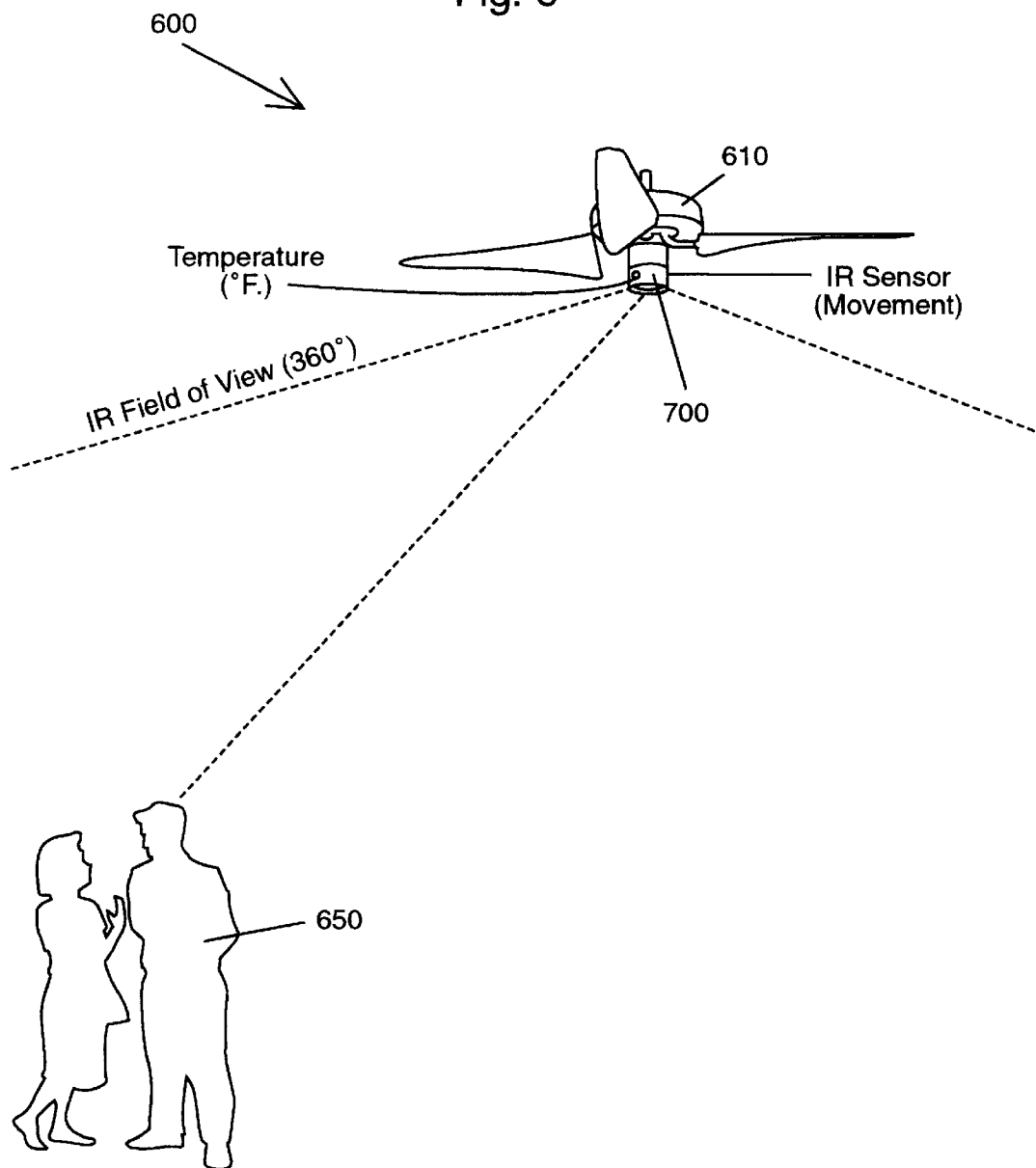
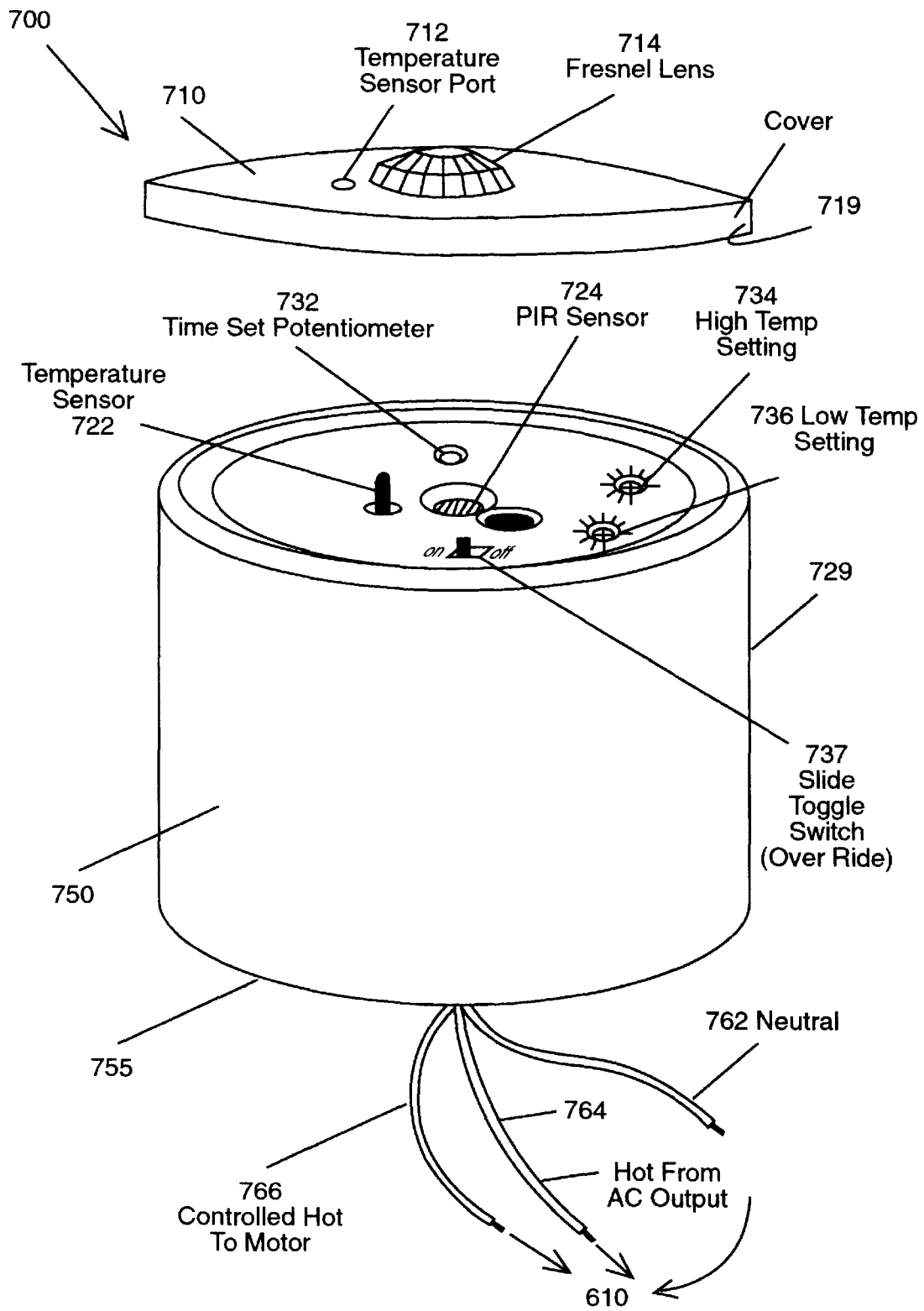

Fig. 7



AUTOMATIC OCCUPANCY AND TEMPERATURE CONTROL FOR CEILING FAN OPERATION

This invention relates to ceiling fan controls, and in particular to an automatic occupancy and temperature control for ceiling fan operations. This application is a Continuation-In-Part of U.S. patent application Ser. No. 09/056,428 filed on Apr. 7, 1998, entitled: High Efficiency Ceiling Fan, Attorney Docket no. UCF-185, by the same assignee.

BACKGROUND AND PRIOR ART

Overhead ceiling fans have become very popular over in recent years. Problems have developed as to the operations of the fans. For example, traditional fans are often left on when occupants leave rooms with overhead ceiling fans. Thus, the fans can consume unnecessary power in unoccupied rooms. Another problem occurs when newly arriving occupants to new rooms and/or to darkened rooms have to search for hard to find wall toggle switches and/or overhanging chains to turn on the ceiling fans. Warm and/or stuffy rooms can be very uncomfortable to newly arriving occupants, who would have to wait for the rooms to cool down and circulate airflow. Further, turning on and off several fans in a home or building is often so inconvenient that fans are left on.

In prior art searches several patents were cited as of general interest in the art, but still fail to overcome the problems cited above.

U.S. Pat. No. 4,322,632 to Hart et al. describes a "remote load selector", title, that allows for both a ceiling fan motor and a built-in light fixture to be selectively controlled from a single two-conductor hardwire cable connection.

U.S. Pat. No. 4,671,458 to Fukuda et al. describes an "air conditioning apparatus", title, that senses temperatures via an infrared sensor to vary the air conditioner air flow pattern rather than to modify the fan motor speed of a ceiling fan.

U.S. Pat. No. 4,716,409 to Hart et al. describes an "electrical appliance control system" which manually activates a ceiling fan from a remote controlled outlet.

U.S. Pat. No. 4,757,204 to Baldwin et al. describes a ceiling mounted passive infrared intrusion detector with a dome shaped lens.

U.S. Pat. No. 4,787,722 to Clayto describes a Fresnel lens capable of transmitting infra-red energy rays.

U.S. Pat. No. 4,782,213 to Teal describes a "ceiling fan electrically heating environmental air" where the devices heats the air in a room by resistance heaters located on the fan blades, which are activated by a thermostat.

U.S. Pat. No. 4,849,737 to Kirihata et al. describes a "person-number detecting system" for using infrared sensors to detect the numbers of people per room.

U.S. Pat. No. 4,990,908 to Tung describes a "remote power control for dual loads" for supplying power to a ceiling fan and light kit.

U.S. Pat. No. 5,033,113 to Wang describes an "Infrared Receiver System For A Remote Control Ceiling Fan", title. The Wang devices describes an attachment device for positioning an infrared sensor beneath the fan for receiving an infrared signals for a remote control ceiling fan.

U.S. Pat. No. 5,124,566 to Hu describes a shutoff circuit for a light sensor controlled switch.

U.S. Pat. No. 5,187,472 to Hart et al. describes a "remote control system for combined ceiling fan and light fixture",

title using a wall mounted thermostat to send radio signals to alter fan speed and energization.

U.S. Pat. No. 5,189,393 to Hu describes a combination type sensor using both passive infrared (PIR) and ultrasonic sensing, as an automatic sensor controlled switch that can detect motion in a room to turn on or off lights, for instance.

U.S. Pat. No. 5,406,173 to Hu describes an occupancy sensor that senses ambient light levels to control the dimming of lights.

U.S. Pat. No. 5,488,273 to Chang describes a "ceiling fan and light assembly control method", title, using a sounding detector to turn on and off a ceiling fan and light kit.

U.S. Pat. No. 5,511,943 to Chang describes a "single throw switch circuit controlling a ceiling fan" that controls ceiling fan speed using a manual switch.

U.S. Pat. No. 5,559,406 to Chang describes a "ceiling fan and light assembly control circuit with remote controller/single-throw switch optional controls" that uses an infrared remote sending unit to send a signal to a receiving unit.

U.S. Pat. No. 5,627,527 to Mehta describes a "thermostatically controlled remote control for a ceiling fan and light" using household wiring to send signals to alter fan speed.

U.S. Pat. No. 5,637,040 to Kim et al. describes an "infrared object detector" that uses an infrared sensor to detect the distance between persons and an air conditioner to adjust air conditioner fan speed and baffled air direction.

None of the cited patents adequately and sufficiently overcome the problems previously described above, particularly the problem of ceiling fans being inadvertently left on for long periods of time when no one is present.

SUMMARY OF THE INVENTION

The first objective of the present invention is to provide a ceiling fan control system using an infrared sensor to detect room occupants to turn the fan on and off.

The second object of this invention is to provide a ceiling fan system to sense room temperature in order to vary the speed (revolutions per minute (rpm)) of the ceiling fan.

The third object of this invention is to provide a ceiling fan system control for on and off operation and speed control which is directly attached to the ceiling fan housing.

The fourth object of this invention is to provide a ceiling fan system, particularly the problem of ceiling fans that eliminates inadvertently leaving the fans on for long periods of time when no one is present.

The fifth object of this invention is to provide a ceiling fan control system that can sense occupants across a wide 360 degree field for operating the fan.

The sixth object of this invention is to provide a ceiling fan control system that can suspend motion control during hours of darkness when occupants are sleeping.

A preferred embodiment of the invention includes a housing that mounts onto a ceiling fan itself generally in the location of where lights can be attached to the motor housing. The housing includes an infrared passive (PIR) sensor and adjustable control for turning the fan on and off based on motion of person(s) approaching and leaving a selected area beneath the fan, a time delay potentiometer and adjustable control for turning the fan off after a preselected period when no motion is sensed, and temperature sensor and adjustable controls for varying speed of the fan based on preselected temperatures. A photocell on the housing senses light to allow the fan to operate when the area beneath the

fan is dark. A removable cap covers the controls for high and low temperature settings and time settings for operation. The cap cover has a fresnel lens that covers the PIR sensor underneath, and a temperature sensor protrudes from a slot in the cover.

With the cap off, a Phillips head screw driver can be used to set the temperature and time settings with the cap cover off. A first temperature setting screw can turn the fan off when sensed temperature is below a first preselected temperature. A second temperature setting screw having a second preselected temperature greater than the first preselected temperature, can be used to turn the fan on to a first rotation speed when the sensed temperature is between the first preselected setting and a halfway point to the second preselected setting. With the temperature setting screws, the fan turns to a second rotation speed when the sensed temperature is greater than the halfway point to the second preselected setting, and the fan turns to a third rotation speed when the sensed temperature is greater than the second preselected setting. On the fan the third rotation speed of the moving blades is greater than the second rotation speed which is greater than the first speed.

For the control of ceiling fans it is advantageous to achieve different attributes for an occupancy based control. Additional benefits of the subject invention are the ability to sense occupants across a wide 360 degree field, the ability to suspend motion control during hours of darkness when occupants are sleeping, and the ability to automatically vary ceiling fan speed with the room air temperature. Ultrasonic type occupancy sensors are not appropriate since ceiling fan motion would induce false triggering of the device. Automatic controls which can dim lights in response to available daylight are not appropriate to ceiling fan control since motor speeds should ideally be altered in response to temperature rather than ambient light.

Further objects and advantages of this invention will be apparent from the following detailed description of a presently preferred embodiment which is illustrated schematically in the accompanying drawings.

BRIEF DESCRIPTION OF THE FIGURES

FIG. 1 is a flow chart of the overall operation of the novel ceiling fan control system.

FIG. 2 shows a block diagram of the fan control with an occupancy-only based control unit, that turns the fan on/off with respect to sensed occupancy, but does not alter a manually set fan speed.

FIG. 3 shows a schematic circuit of the occupancy sensing portion of the control system of FIG. 2.

FIG. 4 shows a block diagram of the fan control with both occupancy and temperature based fan motor speed control, which will turn the fan on and off based on sensed occupancy and will alter the fan motor's operating speed based on sensed temperature.

FIG. 5 is a schematic circuit of the thermal condition speed control portion of the fan control system of FIG. 4.

FIG. 6 shows a preferred embodiment of using the ceiling fan control system with an overhead ceiling fan.

FIG. 7 is an enlarged side view showing the components of the previous figures mounted into a housing 700 that attaches to a motor housing of a ceiling fan shown in FIG. 6 with the controls mounted therein for setting temperature, time, and occupancy.

DESCRIPTION OF THE PREFERRED EMBODIMENT

Before explaining the disclosed embodiment of the present invention in detail it is to be understood that the

invention is not limited in its application to the details of the particular arrangement shown since the invention is capable of other embodiments. Also, the terminology used herein is for the purpose of description and not of limitation.

The novel ceiling fan control system of the subject invention was tested at the Florida Solar Energy Center® (FSEC®). FIG. 1 is a flow chart of the overall operation of the novel ceiling fan control system.

A preferred operation of the novel ceiling fan control is described in the flow chart shown in FIG. 1, which gives an overview of the function of the schematics shown in greater detail in reference to FIGS. 2-5. The control system sequence begins to operate when electrical power is applied to the novel control 100. The passive infrared (PIR) sensing detector immediately begins to scan through a 360 degree compound fresnel lens. The Detector senses movement within its field of view at state 101, it checks to see if a manual override has been set or the control does not sense thermal conditions 102. If the PIR sensors does not detect movement, it checks to see if the set time delay is expired 103. If the time delay has expired, the control switches off the fan motor 104. If, the time delay has not expired, the control checks to see if manual override has been set or the control unit does not include temperature based speed control 102(the invention can be used and only manufactured with an occupancy-based control and without a temperature based control). If the override is specified or the unit is an occupancy sensing only model, it maintains the current ceiling fan speed at state 105. If manual override is not set (or the control unit does not include temperature based speed control), the control checks to see if the room temperature is below the minimum setting 106. If room temperature is below the setting, the control deactivates the fan motor 104. Otherwise, the control checks to see if the temperature is greater than the low setting and less than the mid-point between the high and low setting at state 107. If this is true, the control sets the fan speed to low speed 108. If the temperature is equal to or greater than the mid point of the set range, the control determines whether the temperature is less than the high temperature set 109. If it is not, the control sets the fan motor to medium speed 110. If the temperature is greater than the high speed value, the fan is set to high speed at state 111. The entire sequence of FIG. 1 is repeated as long as the fan control is powered.

The ceiling fan control system is generally illustrated in FIGS. 2 and 4 with a detailed description of the circuit schematics shown and described in reference to FIGS. 3 and 5.

FIG. 2 shows a block diagram of the fan control with an occupancy-only based control unit, that turns the fan on and off with respect to sensed occupancy, but does not alter a manually set fan speed. AC power 201 such as that coming from a 120 volt wall power supply provides electricity to a DC conversion circuit 202. The power conversion circuit 202 energizes the passive infrared sensing detector 203. Based on the state of the occupancy sensing, and the set time delay(for example, approximately 15 seconds to approximately 30 minutes), a signal is provided to a relay control circuit 204. The control of the time set delay will be described in greater detail in reference to FIG. 7. When occupancy is sensed or a time delay from a previous sensing has not expired, the relay completes a switch 205 providing power to the ceiling fan motor 206.

FIG. 3 shows a schematic circuit of the occupancy sensing portion of the control system. The present invention depicts a shutoff control for a sensor controlled switching apparatus

designed specifically to control ceiling fans. 120 volts of AC power **301** comes into the power supply and is transformed and regulated using regulators **D3** and **U2** to provide 24 volts **302** and 6 volts **303** DC out. All grounds through-out the diagram (upside down open arrow) are tied to the power supply ground **304**. Power is provided **305** to the biasing network **306** which includes capacitors **C1** to **C4** and Resistors **R1** and **R2**. The passive infrared sensor **Q1 307** provides its output to Ampl **308** on **U1**, the Application Specific Integrated Circuit (ASIC) **309**. A photocell (CDS **1310**) senses light and provides output to VSS on the ASIC. An oscillator circuit **312** consisting of **R8**, **C9** provides output to **RC1** on the ASIC to operate the circuit clock. A trim potentiometer circuit **VR2** and **R8 313** is used to allow adjustment of the PIR sensing time delay. This is an innovation in the circuit to reduce the cost. Thus, the sensitivity adjustment circuits that were required on Prior art patents U.S. Pat. No. 4,820,938 to Mix et al. and U.S. Pat. No. 5,124,566 to Hu, have been eliminated in interest of inexpensive manufacture. Manual override of PIR control is provided by a switch **314**. An amplifier circuit **315** consisting of **C10**, **C11** and Resistors **R7** provide signal conditioning as selections from the trim adjustments and switches feed into the ASIC board. This integrated circuit **309** processes the various signals and switch selections to determine the status of the Motion Control Output (MCO) **316** which consists of a relay **317** which turns on and off the fan motor **318** based on conditions of using the occupancy sensing and the time delay. **Q5** and **R6 315** energize the relay coil to turn on and off the fan. A unique feature is that if the photocell **310** senses light, it will allow the occupancy output to be altered; without light it will not alter its final state until light is again sensed. This prevents the fan from being turned off in bedrooms while motionless occupants are sleeping. Other innovations in the circuit includes changes to the power supply **302-304**, so that AC power can be used which reduce its size and cost of manufacture, deletion of LED test output and substitution of a trim potentiometer for dip switches all configured to reduce the size of components to fit on a ceiling fan control housing and to reduce the cost of manufacturing.

FIG. 4 shows a block diagram of the fan control with both occupancy and temperature based fan motor speed control, which will turn the fan on and off based on sensed occupancy and will alter the fan motor's operating speed based on sensed temperature. 120 Volt AC power **401** provides electricity to a DC conversion circuit **402**. The power conversion module energizes the passive infrared sensing mechanism **403**. Based on the state of the occupancy sensing, and the set time delay, a signal is provided to the motor control circuit **404**. Occupancy sensing can be activated or turned off using a two-position override toggle type switch and the time delay can be set with a Phillips head screwdriver, both of which are shown and described in greater detail in reference to **FIG. 7**.

Referring to **FIG. 4**, when occupancy is sensed or the time delay from previous sensing has not expired and sensed temperature is greater than the lower limit set, the motor control circuit **404** provides power to the ceiling fan motor **405** and adjusts fan speed based on sensed temperature conditions which are shown and described in more detail in reference to **FIG. 7**.

FIG. 5 is a schematic circuit of the thermal condition speed control portion of the fan control system. The armature winding (**L1, 501**) and the field winding (**L2, 502**) of the fan motor (**405 FIG. 4**) are each connected to the AC line (Neutral **503**). The other side of **L1** is connected to capacitor

C4 504. The other side of **C4** connects to one side of **L2** noted as Node A. The line voltage is connected to Node A through **C5 505** when relay **K1 506** is energized. Positive **507** is connected to Node A through parallel combination of **C1 508** and **C6 509** when **K2 510** is energized. Positive is connected to Node A directly when **K3 511** is energized. Relays **K1 506**, **K2 510** and **K3 511** are enabled by the occupancy sensor control circuit (see **FIGS. 2** and **3**) when occupancy is detected. A solid state temperature sensing semi-conductor **SI 8** reads the air temperature just outside the control surface. None of the relays (**K1 506**, **K2 510**, **K3 511**) are energized except for **512**, if the temperature is less than 74° F. **K1 506** is energized when the sensed temperature is greater than or equal to 74° F. and less than 77° F. **K2 510** is energized if the temperature is greater than or equal to 77° F. and is less than 80° F. Relay **K3 511** is energized if the sensed temperature is greater than 80° F. The large circuit shown as **513** provides an analogue to digital conversion for the temperature signal. The trim potentiometer **514**, allows adjustment of the temperature control high setting, while **VR1 519**, allows control of the low setting. The reference voltage for the temperature sensor is supplied by **R9** and **D2 516**, while **VR3 515**, allows calibration of the temperature reading. The solid state device **Q2** and resistor **R6 520**, enables the analogue to digital converter. The light sensing mechanism **521** allows suspension of the control being changed during darkness. The unmarked remainder of the circuit is identical to **FIG. 3**.

FIG. 6 is a preferred embodiment **600** of using the ceiling fan control system **700** with an overhead ceiling fan **610** motor and fan blades, wherein sensed occupants **650** can operate the fan and temperatures can be used to activate and deactivate fan operation.

FIG. 7 is an enlarged side view showing the components of the previous figures mounted into a housing **700** that attaches to a motor housing of a ceiling fan shown in **FIG. 6** with the controls mounted therein for setting temperature, time, and occupancy. The IR sensor **724** can be a PIR cell model no. RE200B manufactured by NICERA.

Referring to **FIG. 7**, the housing **750** holding the invention can be attached to an existing motor mount on a ceiling fan system that has a light kit attachment capability, such as but not limited to using a raised ridge **755** with internal threads to mount the housing to the motor (**610** shown in **FIG. 6**). The cap cover **710** which protrudes from the lower part of the housing **700** when mounted, has a fresnel lens **713** that covers the PIR sender **724** underneath, and a slot/port **712** for allowing the elongated temperature sensor **722** to protrude therefrom. The cap cover **710** can be attached to the main housing **750** by fasteners such as but not limited to mateable threads **719**, **729**, respectively. The temperature setting can be accomplished by adjusting Phillips head screws **734** and **736** which set the high and low temperatures for the invention. The high setting **734** can be adjusted to turn the fan on, for example to 78 degrees at which the fan blades will be set to rotate on. The low temperature setting **736** is the setting at which the fan will turn off, for example 70 degrees.

Referring to **FIG. 7**, the operation of the temperature set screws **734**, **736** will now be described. Set screw **734** determines the temperature at which the fan will be set to maximum speed. Turning set screw **734** to its fully counterclockwise position sets the high temperature setting to its maximum 90 F.; setting screw **734** to fully clockwise sets it to its minimum 75 F. Set screw **736** determines the temperature at which the fan will be turned off. Turning set screw **736** determines the temperature at which the fan will

be turned off. Turning set screw **736**(low temperature setting) to its fully counterclockwise position sets the low temperature setting to its maxima of 75 F. Setting screw **736** to its fully clockwise position sets it to its minimum of 68 F. If the high speed minimum is set lower than the low speed maxima, the high speed setting takes precedence. Markings about the screws **734**, **736** can give the user direction as to the setting temperature. Although, hash marks are shown in the FIG. 4, other types of markings can be used.

Referring to FIG. 7, occupancy sensing can be activated or turned off using a two-position override toggle type switch **737**. Slide switch **737** allows override of the control. Photocell **738** allows the control change to be defeated and inoperable during darkness conditions in the room where the invention is being used.

Referring to FIG. 7, the operation of time set potentiometer **732** will now be described. The time delay in the time set potentiometer **732** can be set with a Phillips head screwdriver. Setting the time set **732** fully clockwise will set the time delay at its minimum of 30 seconds. Setting the time set fully clockwise will set the time delay at its maximum of 30 minutes. Setting screw **732** allows the fan to be turned off after preselected delay times(i.e. 30 seconds to 30 minutes) when no motion has been sensed by the invention.

Again referring to FIG. 7, invention **700** can be wire connected through a neutral wire **762**, hot wire from the AC Output wire **764** and Controlled Hot to Motor wire **766**, which can be color coded, to existing matching wires in the ceiling fan **610** shown in FIG. 6.

While the invention has been described, disclosed, illustrated and shown in various terms of certain embodiments or modifications which it has presumed in practice, the scope of the invention is not intended to be, nor should it be deemed to be, limited thereby and such other modifications or embodiments as may be suggested by the teachings herein are particularly reserved especially as they fall within the breadth and scope of the claims here appended.

I claim:

1. A ceiling fan control system directly attached to an overhead air circulating ceiling fan for controlling the on and off, and rotation speed of the fan, comprising in combination:

an overhead ceiling fan and motor housing for being connected to a ceiling for circulating air;

non-ultrasonic sensor directly attached onto the motor housing for turning the fan on and off based on a person approaching and leaving a selected area beneath the fan;

a temperature sensor directly attached onto the motor housing for varying speed of the fan based on preselected temperatures; and

at least one mechanical setting control directly attached to the motor for controlling at least one of: a time delay for turning off the ceiling fan after a preselected time when no motion has been sensed and a temperature setting for activating the temperature sensor.

2. The ceiling fan control of claim 1, wherein the non-ultrasonic sensor includes:

a passive infrared sensor.

3. The ceiling fan control system of claim 2, further including: a fresnel lens.

4. The ceiling fan control system of claim 1, wherein the time delay further includes:

a time set potentiometer control attached to the fan motor for turning the fan off after a preselected period when no motion is sensed.

5. The ceiling fan control system of claim 4, wherein the control includes:

a set screw which can be turned to various time settings.

6. The ceiling fan control system of claim 1, wherein the temperature sensor further includes:

a first temperature setting means for turning the fan off when sensed temperature is below a first preselected temperature.

7. The ceiling fan control system of claim 6, wherein the temperature sensor further includes:

a second temperature setting means having a second preselected temperature greater than the first preselected temperature, wherein the fan turns on to a first rotation speed when the sensed temperature is between the first preselected setting and a halfway point to the second preselected setting, the fan turns to a second rotation speed when the sensed temperature is greater than the halfway point to the second preselected setting, and the fan turns to a third rotation speed when the sensed temperature is greater than the second preselected setting, and wherein the third rotation speed is greater than the second rotation speed which is greater than the first rotation speed.

8. The ceiling fan control system of claim 7, further comprising:

a first manual adjustment means for controlling the first preselected temperature; and

a second manual adjustment means for controlling the second preselected temperature.

9. The ceiling fan control system of claim 1, further comprising:

means for sensing light to allow the fan to operate when the area beneath the fan is dark.

10. The ceiling fan control system of claim 1, further comprising:

a support means for housing the non-ultrasonic sensor.

11. A ceiling fan control system directly attached to an overhead air circulating ceiling fan for controlling the on and off, and rotation speed of the fan, comprising in combination:

an overhead air circulating ceiling fan and motor housing for being connected to a ceiling;

non-ultrasonic sensor directly attached onto the motor housing;

a first mechanically adjustable control for the non-ultrasonic sensor directly attached onto the motor housing;

a time delay means to turn the fan off after a preselected time when no motion is sensed;

a second mechanically adjustable control for the time delay means directly attached onto the housing;

temperature sensor means directly attached onto the motor housing for varying speed of the fan based on preselected temperatures; and

a third mechanically adjustable control for the temperature sensor means directly attached to the housing.

12. The ceiling fan control system of claim 11, further comprising:

a support means for housing the non-ultrasonic sensor, the temperature sensor, controls for the non-ultrasonic sensor, and controls for the temperature sensor, wherein the support housing directly mounts to the motor housing of the ceiling fan; and

a removable cover for protecting the controls for the non-ultrasonic sensor and the controls for the temperature sensor.

9

13. The ceiling fan control system of claim 12, further including:

a fresnal lens attached to a cover.

14. The ceiling fan control system of claim 11, wherein the time delay further includes:

a time set potentiometer control attached to the fan motor.

15. The ceiling fan control system of claim 11, wherein the temperature sensor further includes:

a first temperature setting means for turning the fan off when sensed temperature is below a first preselected temperature; and

a second temperature setting means having a second preselected temperature greater than the first preselected temperature, wherein the fan turns on to a first rotation speed when the sensed temperature is between the first preselected setting and a halfway point to the second preselected setting, the fan turns to a second rotation speed when the sensed temperature is greater than the halfway point to the second preselected setting, and the fan turns to a third rotation speed when the sensed temperature is greater than the second preselected setting, and wherein the third rotation speed is greater than the second rotation speed which is greater than the first rotation speed.

16. The ceiling fan control system of claim 11, further comprising:

a first set screw for controlling the first adjustable control;

10

a second set screw for controlling the second adjustable control; and

a third set screw for controlling the third adjustable control.

17. The ceiling fan control system of claim 12, further comprising:

means for sensing light to allow the fan to operate when the area beneath the fan is dark.

18. A ceiling fan control system directly attached to an overhead air circulating ceiling fan for controlling the on and off, and rotation speed of the fan, comprising in combination:

means connected to an overhead air circulating ceiling fan housing for sensing occupants beneath the ceiling fan housing so that a fan connected to the ceiling fan housing turns on when the occupants are sensed and turns off when the occupants are not sensed; and

means for deactivating the occupant sensing means during hours of darkness so that the fan remains on after occupants have been sensed.

19. The ceiling fan control system of claim 18, the ceiling fan housing further comprising:

means for sensing temperature to vary speed of the fan.

20. The ceiling fan control system of claim 18, wherein the sensing means further includes:

a sensing range across a 360 degree field.

* * * * *