

STARS

University of Central Florida
STARS

UCF Patents

Technology Transfer

8-14-2001

Coin Disks

Issa Batarseh

Zihua Qu

University of Central Florida

Samuel Richie

University of Central Florida

Find similar works at: <https://stars.library.ucf.edu/patents>

University of Central Florida Libraries <http://library.ucf.edu>

This Patent is brought to you for free and open access by the Technology Transfer at STARS. It has been accepted for inclusion in UCF Patents by an authorized administrator of STARS. For more information, please contact STARS@ucf.edu.

Recommended Citation

Batarseh, Issa; Qu, Zihua; and Richie, Samuel, "Coin Disks" (2001). *UCF Patents*. 674.

<https://stars.library.ucf.edu/patents/674>





US006273248B1

(12) **United States Patent**
Batarseh et al.

(10) **Patent No.:** **US 6,273,248 B1**
(45) **Date of Patent:** **Aug. 14, 2001**

(54) **COIN DISKS**

(75) Inventors: **Issa Batarseh; Zhihua Qu**, both of
Oviedo; **Samuel Richie**, Orlando, all of
FL (US)

(73) Assignee: **Unversity of Central Florida**, Orlando,
FL (US)

(*) Notice: Subject to any disclaimer, the term of this
patent is extended or adjusted under 35
U.S.C. 154(b) by 0 days.

(21) Appl. No.: **09/572,822**

(22) Filed: **May 16, 2000**

Related U.S. Application Data

(62) Division of application No. 09/106,641, filed on Jun. 29,
1998, now Pat. No. 6,081,410.

(51) **Int. Cl.**⁷ **B65D 85/57**

(52) **U.S. Cl.** **206/308.1; 206/81**

(58) **Field of Search** 206/307, 308.1,
206/309-312, 0.81, 0.82, 232, 38; 24/3.7,
3.5, 3.12

(56) **References Cited**

U.S. PATENT DOCUMENTS

1,555,714	*	9/1925	Kahn	24/3.5
1,713,760	*	5/1929	Kuester	24/3.7
3,526,884		9/1970	Buslik et al.	
4,948,022	*	8/1990	VanDyke	206/308.1
4,971,195	*	11/1990	Mitsuyama	206/311
5,150,354		9/1992	Iwata	
5,208,802		5/1993	Suzuki	
5,253,133		10/1993	Guo	
5,331,627		7/1994	Childers	
5,398,158		3/1995	Fisher	
5,420,739		5/1995	Yokozawa et al.	
5,475,674		12/1995	Yamashita	
5,513,055		4/1996	McGrath	
5,532,889		7/1996	Stefansky	
5,539,599		7/1996	Wilder	
5,579,297		11/1996	Childers et al.	
5,624,027	*	4/1997	Ayers et al.	206/307
5,677,898		10/1997	Hasegawa	

5,715,233	2/1998	Yoshida	
5,788,069	*	8/1998	Calhoun, III et al. 206/308.1
5,816,394	*	10/1998	O'Brien et al. 206/308.1
5,841,605		11/1998	Foster et al.
5,867,476		2/1999	Yoshida et al.

OTHER PUBLICATIONS

Imation Enterprises Corp. "Super Disk Drive", Legal
Notices—Copyright 1996 Imation, pp. 1-7.

Fuji Photo Film Co. Mac Publications "HiFD to support
new, old floppies", MacWeek News, vol. 11 Issue 40, Oct.
17, 1997, pp. 1-3.

Imation Enterprises Corp. "Super Disk", Imation, 1997,
brochure.

* cited by examiner

Primary Examiner—Luan K. Bui

(74) *Attorney, Agent, or Firm*—Brian S. Steinberger; Law
Offices of Brian S. Steinberger

(57) **ABSTRACT**

A floppy disk cartridge adapter having a removable coin shaped memory disk. The 3½ inch size cartridge adapter can fit into conventional personal computer disk drives. The small coin shaped magnetic disk has a diameter of approximately 1 inch, and can be easily snapped into and removed from the cartridge adapter. The coin disk fits on a spindle that is side by side to the floating drive plate used in regular 3½ inch floppy diskettes. The spindle can be attached by various drive systems to rotate simultaneously with the rotating drive plate. One version is belt driven, another has the coin disk snap onto a spindle supported wheel whose sides frictionally rub against the drive plate wheel, and a third version has the coin disk snap onto the spindle supported gear wheel whose sides contain teeth which mateably engage like side teeth on the drive plate wheel. The coin disk can alternatively be inserted into a separate casing having a spring loaded shutter so that the conventional disk drive being used can access the magnetic sides of the coin disk by sliding the shutter. When removed from the cartridge adapter, the disk can be inserted into a small clip retainer which has a paper clip edge allowing the coin shaped disk to be portably mounted on papers, cardboard, clipboards and the like.

8 Claims, 11 Drawing Sheets

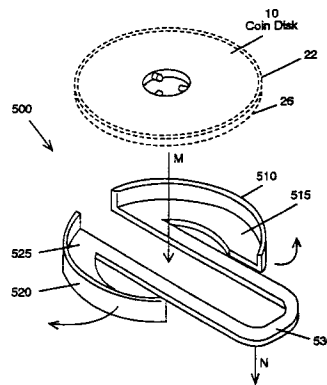

1 ↘

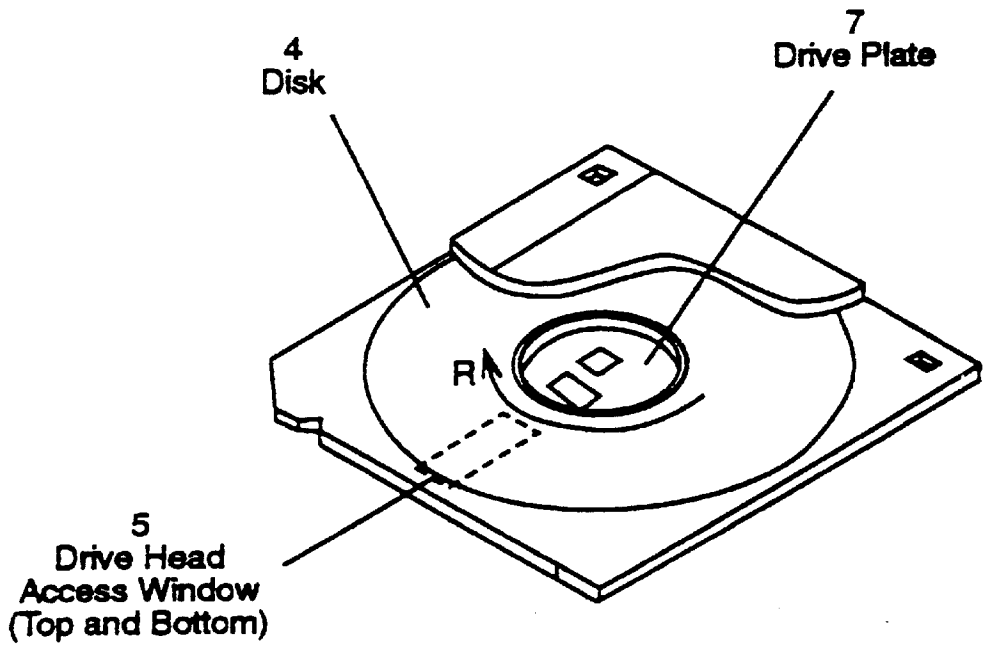
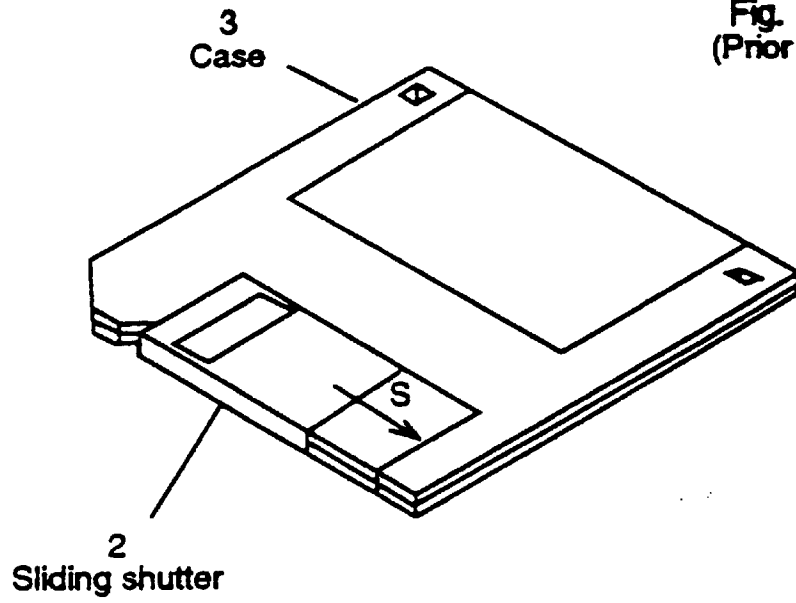

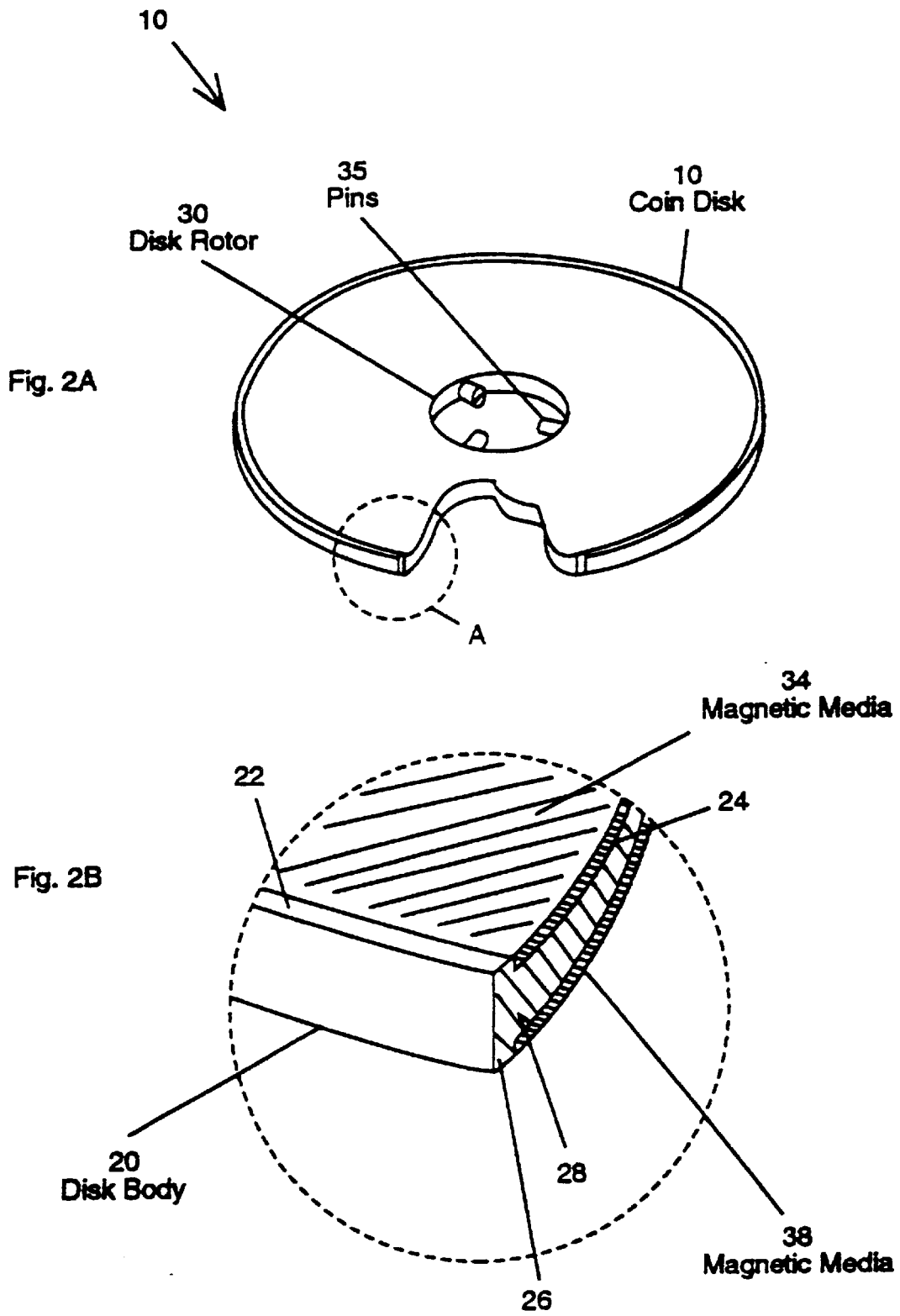

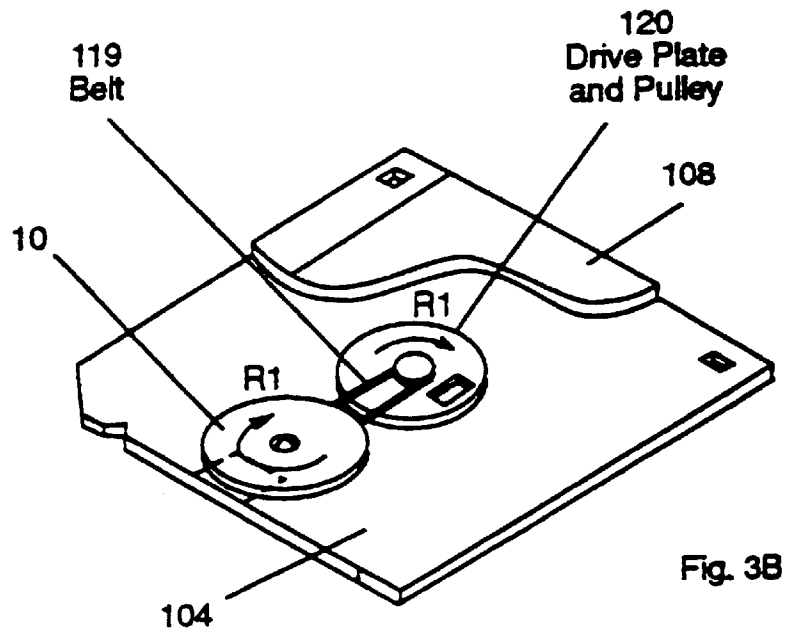
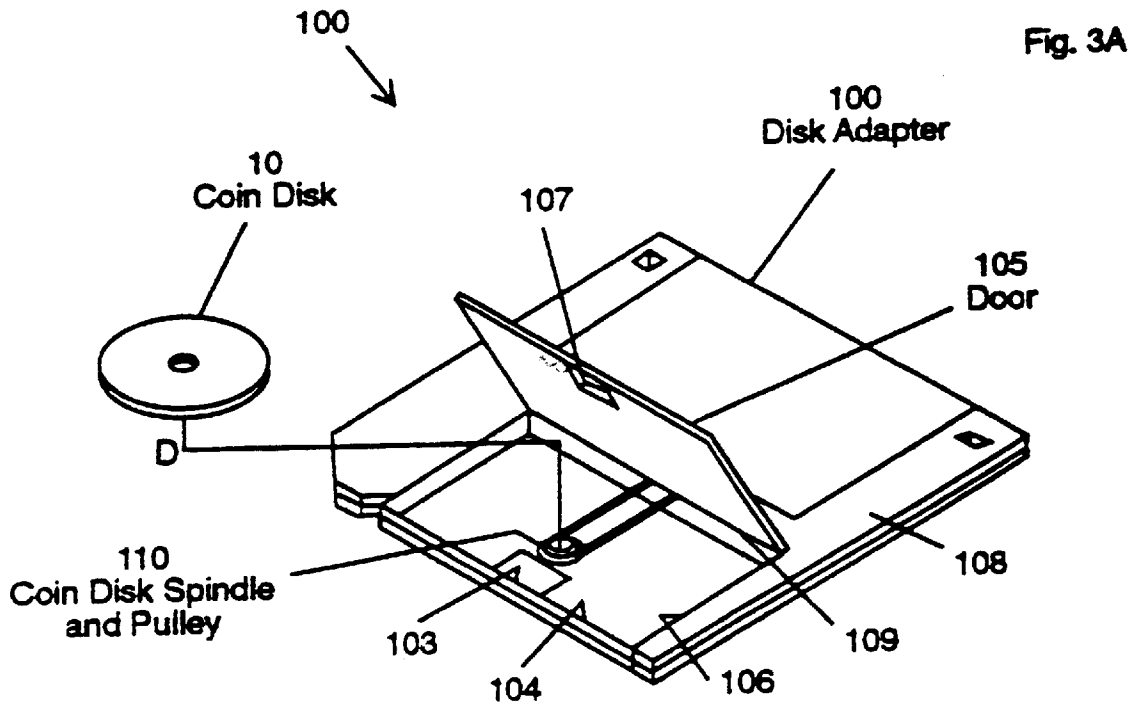

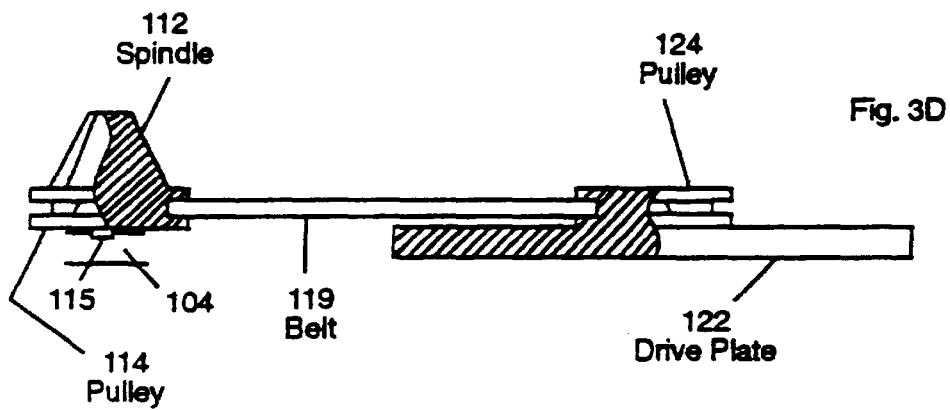
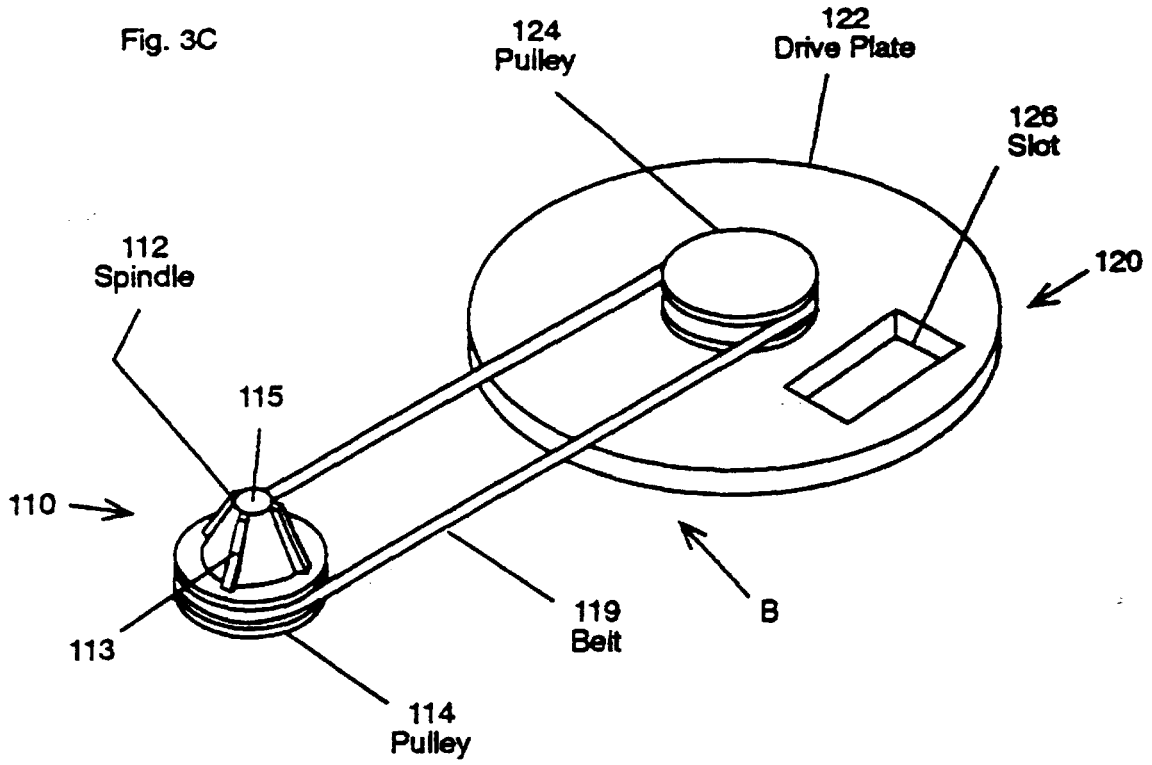

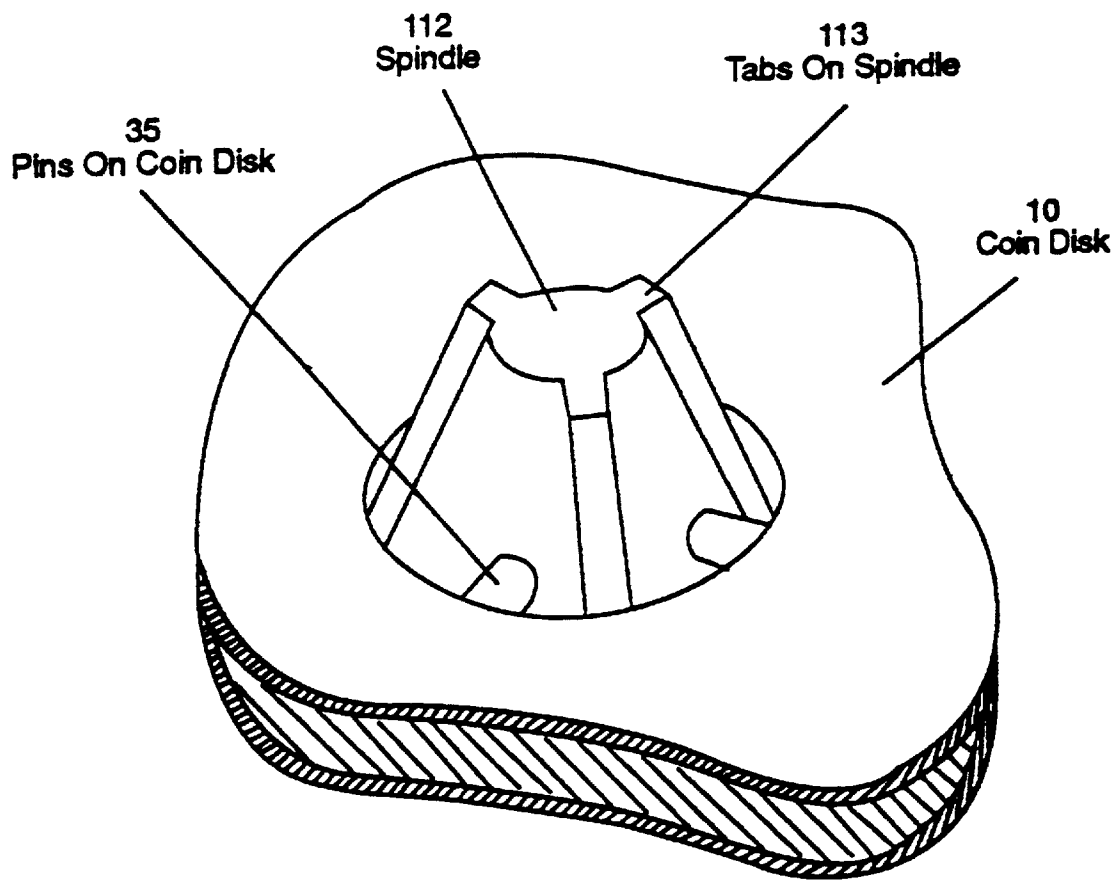
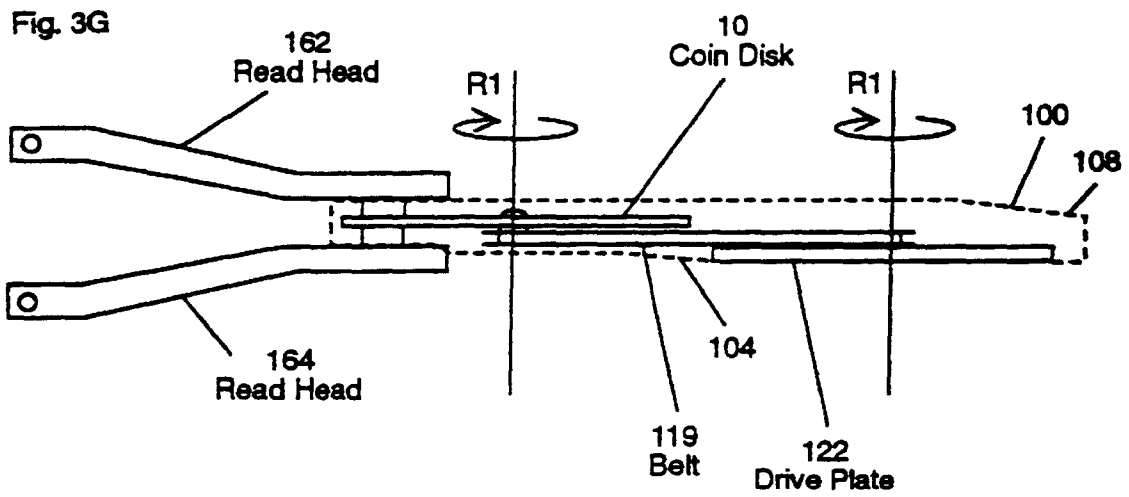
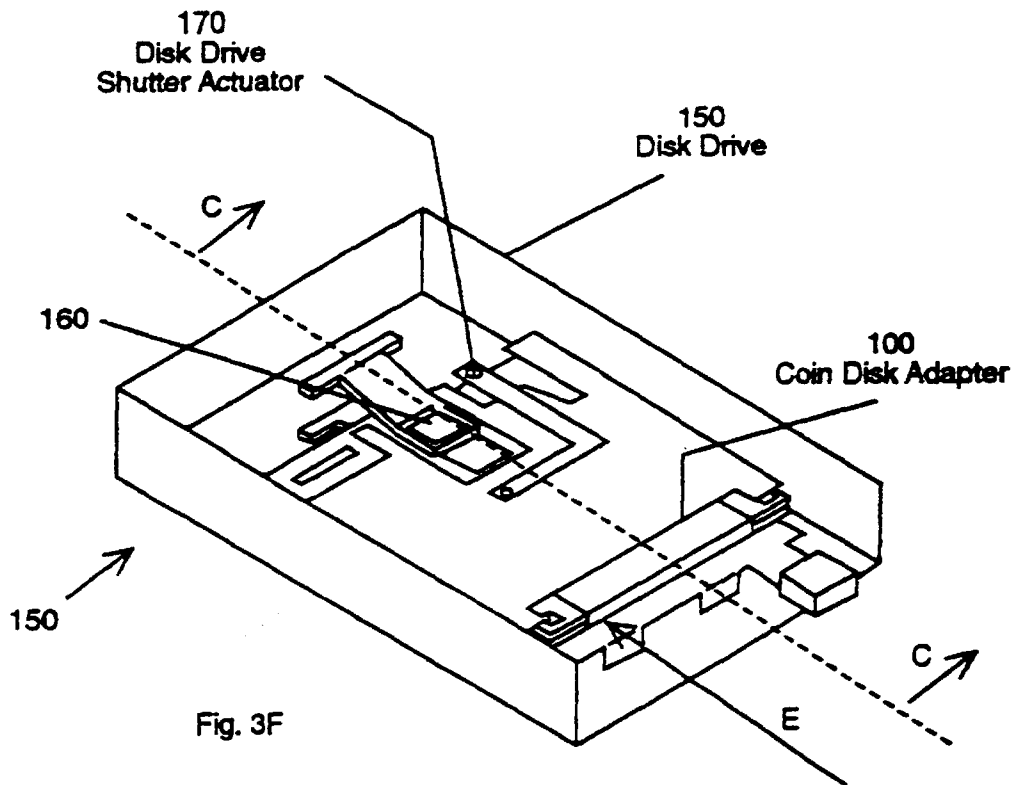
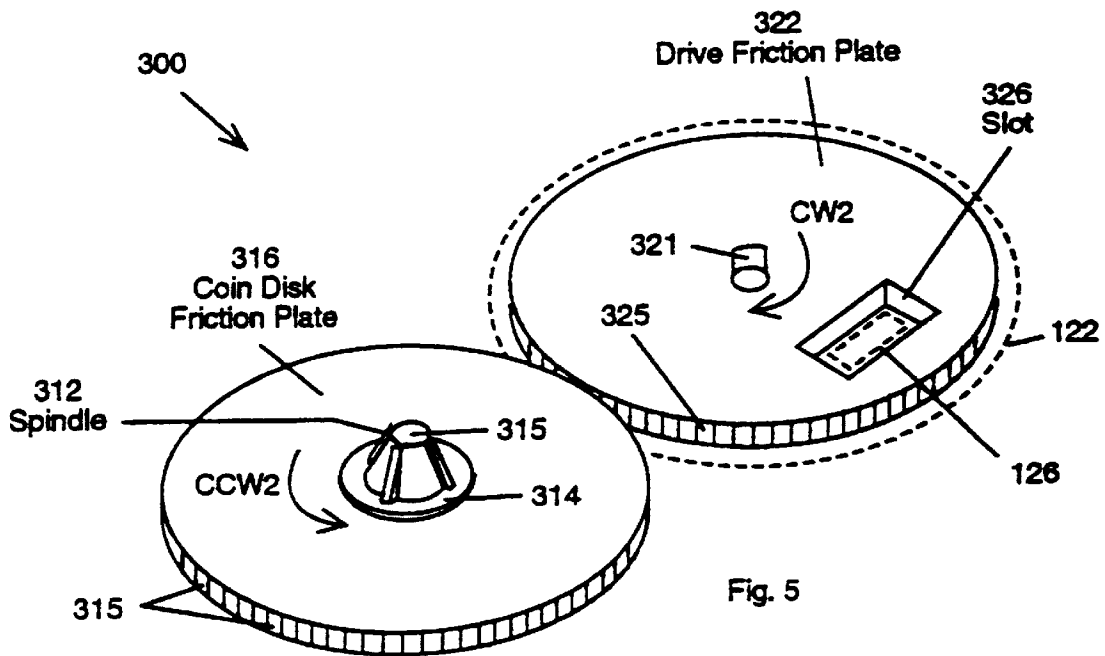
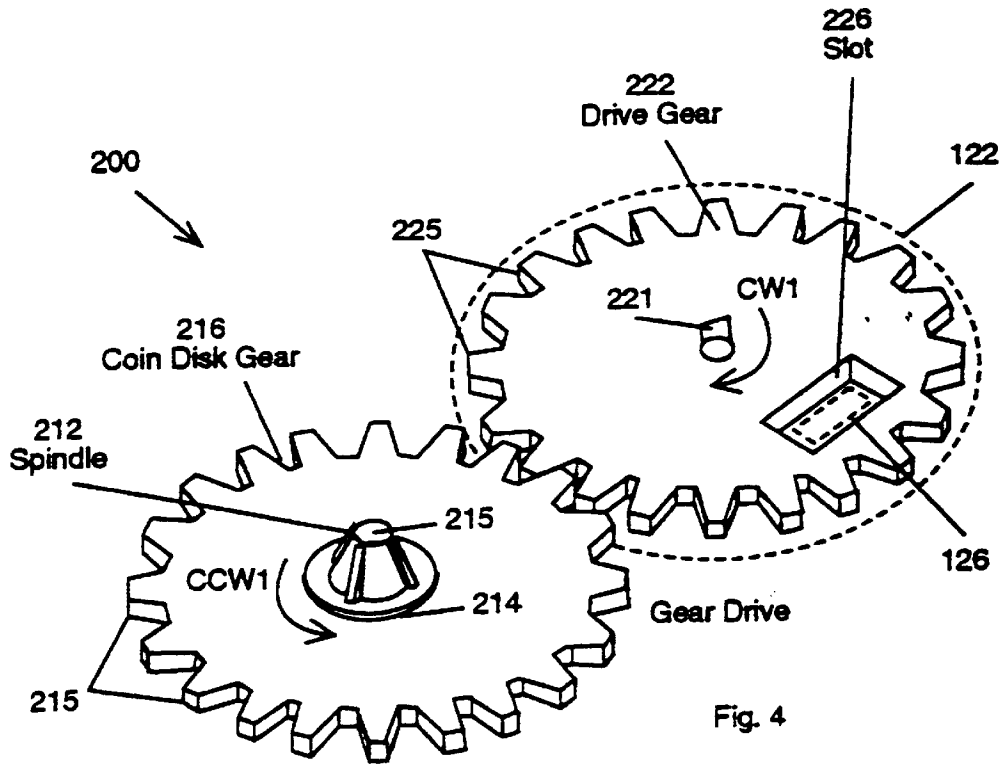
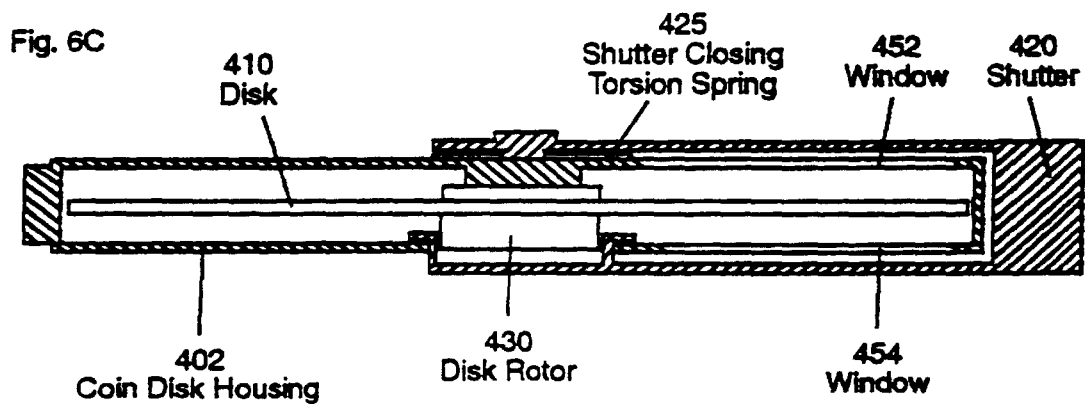
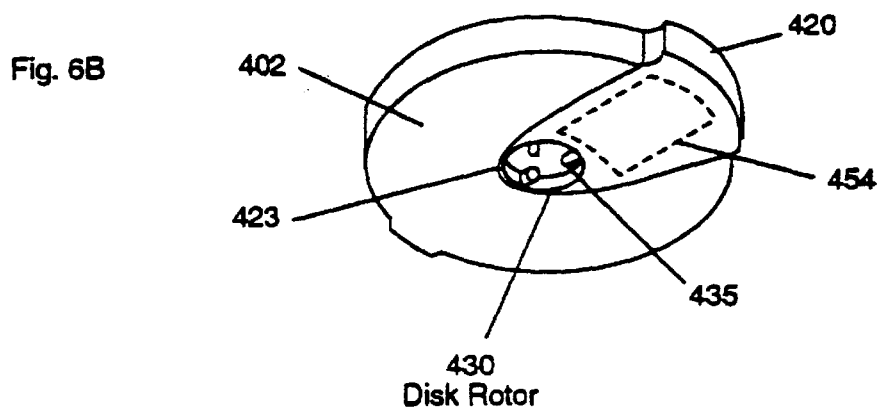
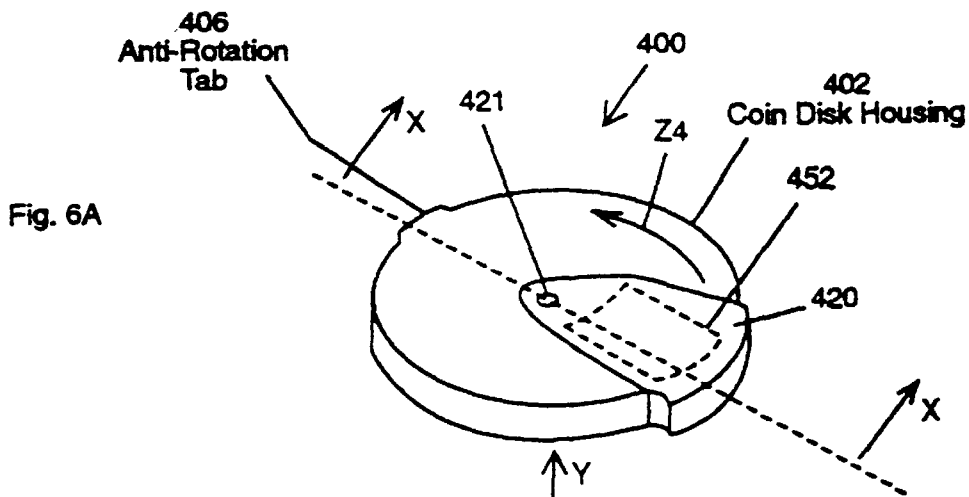

Fig. 3E







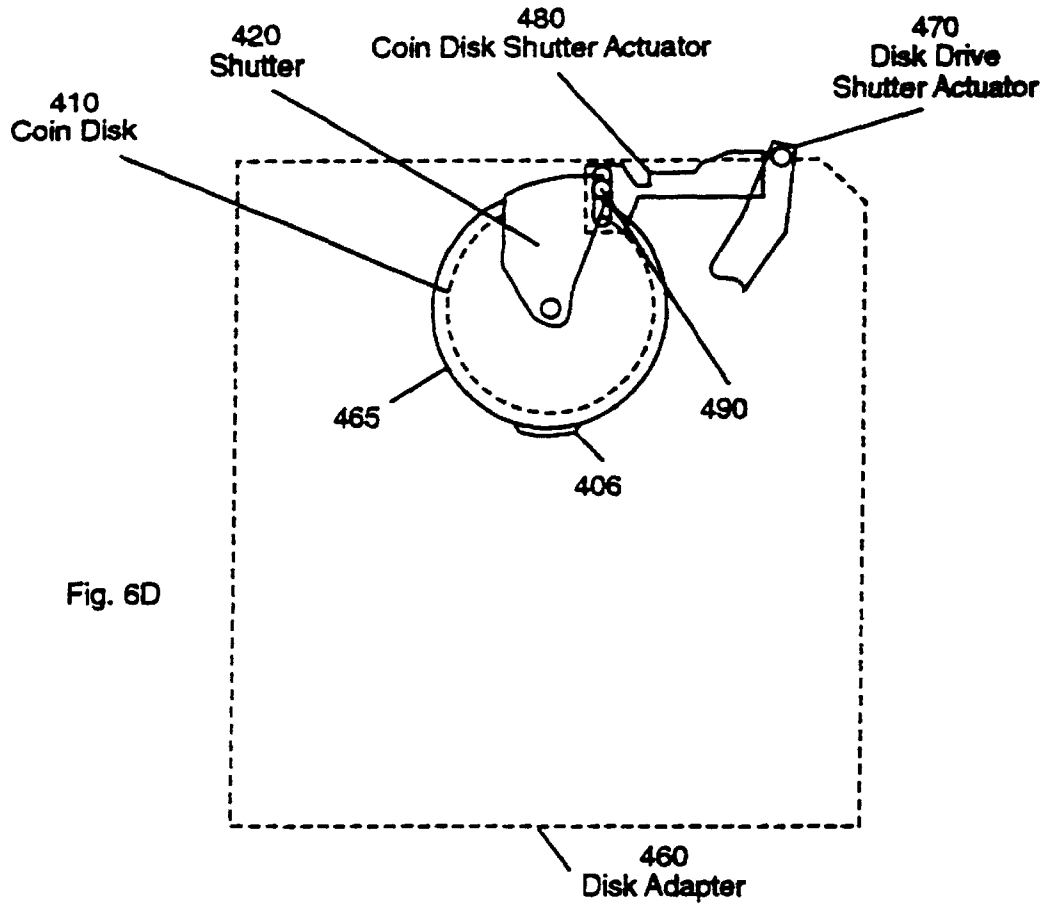

Fig. 6D

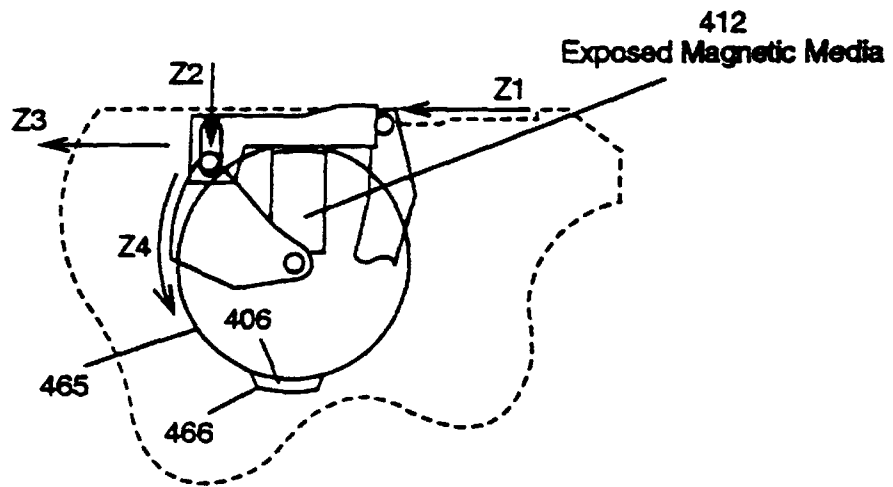
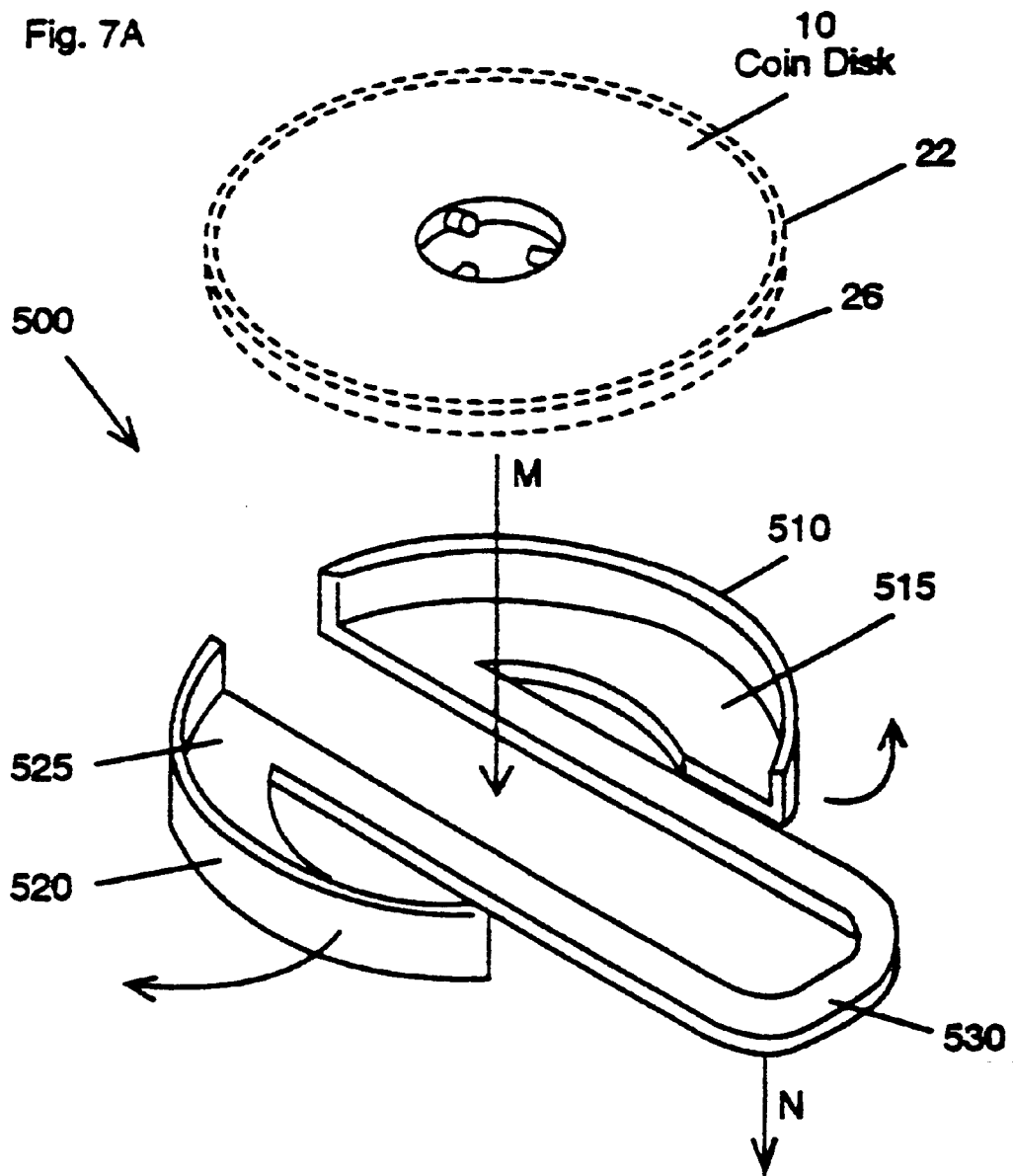
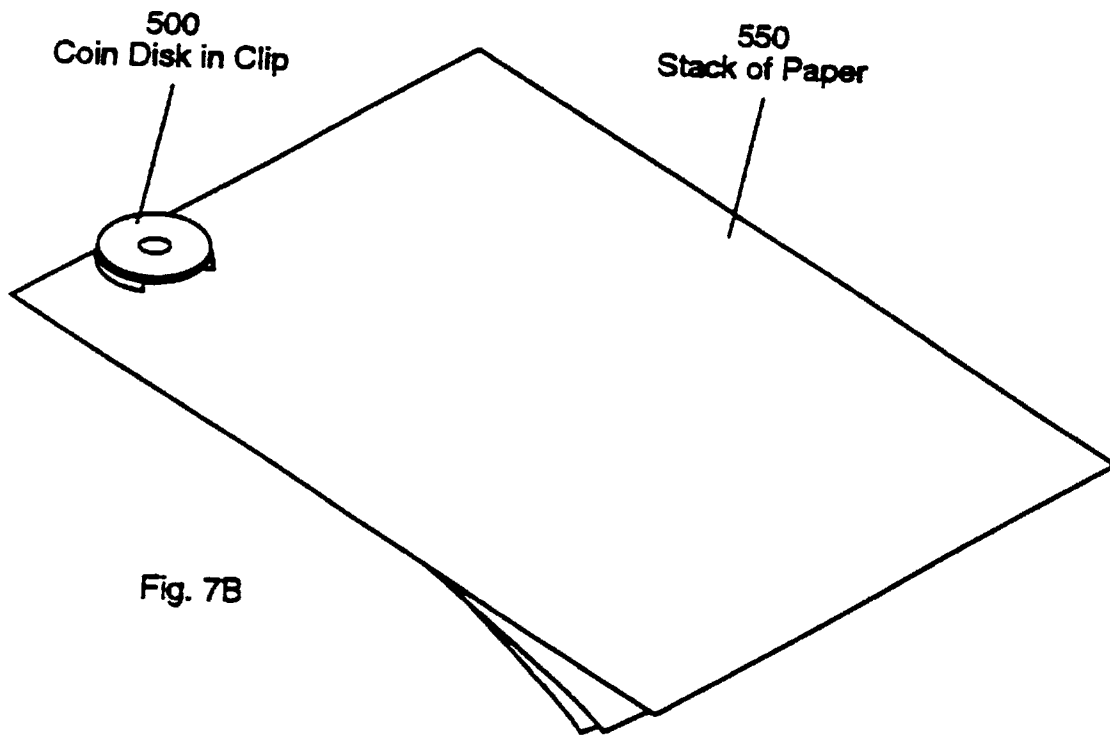

Fig. 6E

Fig. 7A





COIN DISKS

This is a Divisional of application Ser. No. 09/106,641 filed Jun. 29, 1998 U.S. Pat. No. 6,081,410.

This invention relates to computer memory discs, and in particular to an floppy disk sized adapter device that allows removable coin sized disks to record information within conventional personal computer disk drivers.

BACKGROUND AND PRIOR ART

Conventional computer disk drivers on IBM compatible personal computers (PCs) such as those from Compaq, Hewlett Packard, Texas Instruments and even Apple generally use a standard 3½ inch floppy diskette cartridges. It has become a wide practice for persons to manually pass these floppy diskettes around when updating and submitting papers to other parties. Typically, the only way of protecting a single 3½ inch floppy diskette cartridges is to use the paper type sleeve they come in. However, there are problems with being able to manually transport individual diskette cartridges. The paper sleeves are usually paper-thin, easily wear and become torn after a short use. Additionally, the size of these floppy diskette cartridges makes them difficult to attach to hardcopy paper versions with traditional fastening means such as paper clips. The large size of these cartridges can cause the cartridge to become separated from the attached paper and become lost. Furthermore, the bulky 3½ inch rigid square shape of the cartridge requires a storage space of at least those dimensions. The large plastic carrying cases which hold multiple disks are too cumbersome to be used for holding just a single disk. Most 3½ inch floppy diskettes that pass around offices utilize less than 20 to 30% of their storage space resulting in substantial wasted space. Furthermore most 3½ inch diskettes are not passed around in protective paper type sleeves, and as a result the magnetic disk in the diskette cartridges can become demagnetized and even damaged from normal wear and tear.

Cartridge and disk adapters have been proposed over the past several years, but fail to overcome all the problems described above. U.S. Pat. No. 5,208,802 to Suzuki et al. describes a disk adapter for a disk cartridge that uses a spacer-component to fill in the space about smaller sized disks. However, Suzuki '802 requires using a separate plastic disk adapter piece as the spacer-component that detaches from the cartridge housing and thus can become easily damaged, and lost. Furthermore, both this plastic adapter piece and the disk must each be inserted and snapped into place within the housing between uses which would tend to wear out the plastic adapter over time and thus not allow it to be readily reusable. U.S. Pat. No. 5,150,354 to Iwata et al. describes a disk cartridge having a hinged side opening for allowing only a full size magnetic disk to be inserted therein. U.S. Pat. No. 5,475,674 to Yamashita et al. describes a disc case that is limited to only holding full-sized removable magnetic disks. U.S. Pat. Nos. 5,331,627 to Childers et al.; 5,677,898 to Hasegawa et al. and 5,715,233 to Yoshida et al. each describes cartridge adapter devices where one or more smaller cartridges (each housing a disk) can be inserted into a larger cartridge so that the smaller cartridge can work in computers that take the larger cartridges.

SUMMARY OF THE INVENTION

The first objective of the present invention is to provide a 3½ inch floppy disk cartridge useful for computers with a removable and reusable 1 inch coin-sized magnetic disk.

The second object of this invention is to provide a portable computer useable coin shaped magnetic disc that can be handheld and easily stored.

The third object of this invention is to provide a storage holder for a coin sized magnetic storage media that can easily clip onto papers allowing the storage media to be easily transportable.

A preferred embodiment of the adapter cartridge includes a cartridge in the shape of a floppy diskette, a drive plate rotatably attached within the cartridge, a coin shaped magnetic disk connected to the cartridge, and a drive system for allowing the disk to rotate simultaneously with the drive plate. In operation, the cartridge being inserted into a computer disk drive allows the magnetic disk to record and play back data. The magnetic disk can be removed for separate transport and storage from the cartridge. The cartridge can have exterior dimensions of approximately 3.55 inches wide, approximately 3.70 inches long and approximately 0.13 inches thick. The magnetic disk can have a diameter of approximately 1 inch. A spindle in the cartridge allows the magnetic disk to be removably attached to the cartridge so that that the magnetic disk is side by side to the drive plate.

A first version of the drive system can have a belt connecting the rotating drive plate to the magnetic disk so that the drive plate and the magnetic disk simultaneously rotates in the same direction. The drive plate and the coin disk spin axis are joined by a flexible bell. A small pulley is attached to the drive plate and concentrically aligned with the drive plate spin axis. A second pulley mates with the coin disk and is concentrically aligned with the coin disk spin axis. A small belt wraps about the two pulleys. When the drive plate turns, it spins the drive plate pulley which moves the belt which turns the coin disk pulley which spins the coin disk. Equal drive plate pulley and coin disk pulley diameters assure the coin disk spins at the normal angular velocity of the drive.

A second version of the drive system can have a plate wheel supporting the magnetic disk and having rough side edges which abut against rough side edges on the drive plate, so that rotating the drive plate in one direction simultaneously by friction rotates the plate wheel in an opposite direction. A drive plate friction disk is attached to the drive plate and concentrically aligned with the drive plate spin axis. A coin disk friction plate mates with the coin disk and is concentrically aligned with the coin disk spin axis. The two friction disks contact each other at a tangent point with some force between the two friction disks at this pressure point. The friction disks will be made of a material, such as hard rubber, which offer significant frictional force at the pressure point. This assures that the coin disk spins true when the drive plate spins and prevents slippage between the coin disk and the drive plate as they both turn.

A third version of the drive system has a gear wheel for supporting the magnetic disk, the plate wheel having side teeth which mateably interconnect to side teeth on the drive plate, so that rotating the drive plate in one direction simultaneously rotates the gear wheel in an opposite direction. Here a coin disk gear is driven by a drive plate gear. The drive plate gear is attached to the normal drive plate and

is concentrically aligned with the drive plate spin axis. The coin disk gear mates to the coin disk and is concentrically aligned with the drive plate spin axis. The coin disk gear mates to the coin disk and concentrically aligned with the coin disk spin axis. Both gears mesh together at a tangent point and when the drive turns the drive plate, the gears turn the coin disk. Equal gear diameters and equal numbers of teeth on both gears assure that the coin disks angular velocity is equal to the normal drive velocity.

A novel attachment device sized slightly larger than the coin disk can be used for attaching the coin disk to a single sheet of paper, a stack of paper, cardboard and even a clipboard. The attachment device has a compartment for snapably receiving side edges of the coin disk therein, and a clip for attaching the device to the edge of the sheet.

Further objects and advantages of this invention will be apparent from the following detailed description of a presently preferred embodiment which is illustrated schematically in the accompanying drawings.

BRIEF DESCRIPTION OF THE FIGURES

FIG. 1A is a perspective view of a prior art 3½ inch floppy disk cartridge.

FIG. 1B is a partial exposed view of the magnetic disk within the cartridge of FIG. 1A.

FIG. 2A is a perspective view of a novel coin disk used in the subject invention.

FIG. 2B is an enlarged cut-out section of the coin disk of FIG. 2A along arrow A.

FIG. 3A is a perspective view of a first preferred embodiment of using the novel coin disk of FIGS. 2A–2B in a novel adapter cartridge.

FIG. 3B is a partial exposed view of the interior of the novel adapter cartridge of FIG. 3A.

FIG. 3C is an enlarged view of the belt drive system of the adapter cartridge of FIGS. 3A–3B.

FIG. 3D is a side view of the belt drive system of FIG. 3C along arrow B.

FIG. 3E is an enlarged view of the novel disk on the spindle in the cartridge of FIG. 3B.

FIG. 3F is perspective view of the adapter cartridge of the preceding figures inserted into a conventional disk drive.

FIG. 3G is a side view of the adapter cartridge and disk drive of FIG. 3F along arrow C.

FIG. 4 is an enlarged perspective view of a second preferred embodiment drive system for use in the novel cartridge shown in FIGS. 3A and 3B.

FIG. 5 is an enlarged perspective view of a third preferred embodiment drive system for use in the novel cartridge shown in FIGS. 3A and 3B.

FIG. 6A is a top perspective view of an alternative housing for the coin disk of FIGS. 2A–2B.

FIG. 6B is a bottom perspective view of the housing of FIG. 6A along arrow Y.

FIG. 6C is a side cross-sectional view of the housing of FIG. 6A along arrow X.

FIG. 6D is a top view of the coin housing of FIG. 6A mounted in the cartridge adapter of FIG. 3A.

FIG. 6E is an enlarged view of the housing portion of coin disk of FIG. 6D.

FIG. 7A is an enlarged exploded view of a novel attachment device for the novel coin disk of the preceding figures.

FIG. 7B shows the attachment device of FIG. 7A being used with a stack of papers.

DESCRIPTION OF THE PREFERRED EMBODIMENT

Before explaining the disclosed embodiment of the present invention in detail it is to be understood that the invention is not limited in its application to the details of the particular arrangement shown since the invention is capable of other embodiments. Also, the terminology used herein is for the purpose of description and not of limitation.

FIG. 1A is a perspective view of a prior art 3½ inch floppy diskette/cartridge 1. FIG. 1B is a partial exposed view of the magnetic disk 4 within the cartridge 1 of FIG. 1A. Referring to FIGS. 1A–1B, prior art cartridge 1 can be a standard 3½ inch floppy diskette/cartridge (2HD) having a recording capacity of 1.44 MB when formatted, such as but not limited to those manufactured by Iomega, Syquest, Teac, Verbatim, Sony, 3-M, Maxwell, TDK and the like. The standard floppy diskette 1 generally consists of a thin plastic rectangular case 3 approximately 3.55 inches wide, approximately 3.70 inches long and approximately 0.13 inches thick. The magnetic disk 4 inside of case 3, is formed from a round, thin sheet of flexible plastic impregnated with a magnetic material having a diameter of approximately 3.37 inches and a thickness of approximately 0.003 inches (approximately the thickness of a sheet of paper). Glued to the center of disk 4 is a thin metal drive plate 7 which acts like a spindle allowing the disk to rotate in the direction of arrow R. The standard floppy disk 1 of FIGS. 1A–1B includes a sliding shutter 2 which slides in the direction of arrow S on one end of case 3. Under the shutter is an access window 5 located on both sides of case 3 which opens to the magnetic media disk 4. When the diskette/cartridge 1 is inserted into a conventional disk drive, the drive spindle of the disk drive (both not shown since they are not part of the invention), the drive spindle engages the round metal drive plate 7 on the diskette/cartridge and spins the disk 4 at a preselected angular velocity. As the disk 4 spins in the direction of arrow R, heads inside the disk drive read the surfaces of the magnetic disk 4.

FIG. 2A is a perspective view of a novel coin disk 10 used in the subject invention. FIG. 2B is an enlarged cut-out section of the coin disk 10 of FIG. 2A along arrow A. Referring to FIGS. 2A–2B, novel coin disk 10 is comprised of a plastic disk body base 20 having an upper external raised lip edge 22 above a top planar surface 24, and a lower external raised lip edge 26 above a bottom planar surface 28. A top magnetic layer 34 adheres to the top surface 24, while a bottom magnetic layer 38 is adhered to the bottom surface 28. A cylindrical opening 30 forms the disk rotor area of which will be explained in greater detail in reference to FIGS. 3A–3G, includes approximately three inwardly projecting plastic pins 35. Novel coin disk 10 can have an overall diameter of approximately 1.0 inches (the approximate diameter of a quarter), and a thickness of approximately 0.09 inches.

FIG. 3A is a perspective view of a first preferred embodiment 100 of using the novel coin disk 10 of FIGS. 2A–2B in a novel adapter cartridge 100. FIG. 3B is a partial exposed view of the interior of the novel adapter cartridge 100 of FIG. 3A. FIG. 3C is an enlarged view of the belt drive system 110, 120 of the adapter cartridge 100 of FIGS. 3A–3B. FIG. 3D is a side view of the belt drive system 110, 120 of FIG. 3C along arrow B. FIG. 3E is an enlarged view of the novel disk 10 on the spindle 112 in the cartridge 100 of FIG. 3B.

5

Referring to FIGS. 3A–3E, cartridge **100** is a tin plastic rectangular case having overall dimensions identical to the floppy disks of the prior art being approximately 3.55 inches wide, approximately 3.70 inches long and approximately 0.13 inches thick. Novel cartridge **100** includes an upper door **105** with a top drive head access window **107**, hingedly connected **109** to the cartridge body **100**. Door **105** can tightly snap into opening **106** of the upper surface **108** of the cartridge **100**. Opposite the top drive head access window **107** is a bottom drive head access window **103** bottom surface **104** of the cartridge **100**.

Referring to FIGS. 3A–3D, spindle **112** has a center hole for mounting about an axle pin **115** which is secured to lower bottom floor **104** of the cartridge **100**, so that spindle **112** and an adhered to pulley **114** can rotate relative to the cartridge **100**. A drive plate **122** with slot **126** the like components described in reference to FIGS. 1A–1B, similarly floatably fits within the bottom portion of the cartridge **100**. The novel drive plate **122** includes an upper surface attached pulley **124** which connects to pulley **114** by a belt **119** such as a rubber band, and the like.

Referring to FIGS. 3A and 3E, coin disk **10** is inserted into cartridge **100** by manually inserting the disk **10** in the direction of arrow D so that the pins **35** of the disk **10** about between the tabs **113** on the spindle **112** locking the disk **10** in place. Referring to FIG. 3B, drive plate **120** rotating in the direction of arrow R1 uses the pulley **119** to simultaneously rotate disk **10** in the same direction of R1.

FIG. 3F is perspective view of the adapter cartridge **100** of preceding FIGS. 3A–3E inserted into a conventional disk drive **150** of a PC computer. The novel cartridge **100** is inserted inside conventional disk drive **150** as a conventional cartridge of FIGS. 1A–1B is done. FIG. 3G is a side view of the adapter cartridge **100** and disk drive **150** of FIG. 3F along arrow C. Referring to FIGS. 3F–3G, novel cartridge **100** is inserted in the direction of arrow E into the disk drive **150** in the same manner as conventional floppy diskettes are used. The read heads **160** of the disk drive **150** have a top read head **162** which can access the rotating magnetic coin disk **10** through the top drivehead access window **107** (shown in FIG. 3A) in upper surface **108** of the cartridge **100**, while the bottom read head **164** accesses the rotating magnetic coin disk **10** through the bottom drivehead access window **103** (shown in FIG. 3A) in the bottom surface **104** of the cartridge **100**. Note that the conventional disk drive shutter actuator **170** on disk drive **150** is still operable to open the sliding shutter usually found on traditional 3½ inch floppy diskettes. Again drive plate **122** rotating in the direction of arrow R1 by way of belt **119** causes coin disk **10** simultaneously to rotate in the same direction.

FIG. 4 is an enlarged perspective view **200** of a second preferred embodiment drive system for use in the novel cartridge shown in FIGS. 3A and 3B. Referring to FIG. 4, second preferred embodiment includes a drive gear wheel **222** having outer teeth edges **225** which has a lower end that is fixedly secured to a drive plate **122** (similar to the like numbered drive plate of FIG. 3C), by a center pin **221**. A slot **226** passes through a bottom slot **126** of drive plate **122**. Together drive gear wheel **222** and drive plate **122** functions similarly to the like components described in reference to FIGS. 1A–1B, so that drive gear wheel **222** and drive plate **122** fit and float within the bottom portion of the cartridge **100**. Spindle **212** and axle pin **215** and pulley **214** correspond and function similarly to like components **112**, **115** and **114**, respectively of FIGS. 3C–3D. In embodiment **200**, a circular coin disk gear wheel **216** with outer teeth edges **215** is fixably attached about the pulley **214** so that the

6

respective teeth **215** and **225** of both gear wheels **216** and **222** rotate simultaneously with one another. In operation, the novel coin disk **10** of FIGS. 2A–2B is inserted and removed from spindle **212** and functions similarly to the previous embodiment. Note that when drive gear wheel **222** is rotating clockwise (CW), the coin disk gear wheel **216** is rotating counter-clockwise (CCW). Even though the removably attached memory disk **10** rotates in an opposite direction to the drive plate **122**, the same angular rate of speed is maintained and data is recorded and/or played back similarly to that of the previous embodiment.

FIG. 5 is an enlarged perspective view **300** of a third preferred embodiment drive system for use in the novel cartridge shown in FIGS. 3A and 3B. Referring to FIG. 5, third preferred embodiment **300** includes a drive friction plate **322** having outer roughened exterior side edges **325** (such as grooves, rubber edges, and the like) which has a lower end that is fixedly secured to a drive plate **122** (similar to the like numbered drive plate of FIG. 3C), by a center pin **321**. A slot **326** passes through a bottom slot **126** of drive plate **122**. Together drive friction plate **322** and drive plate **122** functions similarly to the like components described in reference to FIGS. 1A–1B, so that drive friction plate **322** and drive plate **122** fit and float within the bottom portion of the cartridge **100**. Spindle **312** and axle pin **315** and pulley **314** correspond and function similarly to like components **112**, **115** and **114**, respectively of FIGS. 3C–3D. In embodiment **300**, a coin disk gear wheel **316** with roughened exterior side edges **315** (such as grooves, rubber edges, and the like) is fixably attached about the pulley **314** so that the respective edges **315** and **325** of both plates **316** and **322** rotate simultaneously with one another. In operation, the novel coin disk **10** of FIGS. 2A–2B is inserted and removed on the spindle **312** and functions similarly to the previous embodiments. Note that when drive friction plate **322** is rotating clockwise (CW), the coin disk friction plate **316** is rotating counter-clockwise (CCW). Even though the memory disk **10** rotates in an opposite direction, the same angular rate of speed is maintained and data is recorded and/or played back similarly to that of the previous embodiment.

FIG. 6A is a top perspective view **400** of an alternative housing **402** for the coin disk **10** (now renumbered **410**) of FIGS. 2A–2B. FIG. 6B is a bottom perspective view of the housing **402** of FIG. 6A along arrow Y. FIG. 6C is a side cross-sectional view of the housing **402** of FIG. 6A along arrow X. FIG. 6D is a top view of the coin housing **402** of FIG. 6A mounted in the cartridge adapter **100** (now renumbered **460**) of FIG. 3A. FIG. 6E is an enlarged view of the coin disk housing **400** of FIG. 6D.

Referring to FIGS. 6A–6E, a plastic coin disk housing **402** has a coin disk **410** (corresponding to coin disk **10** of FIGS. 2A–2B) inserted therein. A central disk rotor opening **430** has interior protruding pins **435** (corresponding to pins **35** of FIG. 2A). A metal shutter rotatably movable in the direction of arrow Z4 hingedly rotates relative to central points **421** and **423** of the housing **402** and is spring loaded by a torsion spring **425** to stay in an initial closed position as shown in FIG. 6A. Moving the shutter in the direction of arrow Z4 exposes top and bottom windows **452**, **454**, respectively exposing the magnetic surfaces **412** (only one is shown here) of magnetic disk **410**. An anti-rotation tab **406** extends from the housing **402** to fit within a mateable edge groove **466** in the cylindrical slot **465** in cartridge **460**. Pins **435** fit about the spindles **112**, **212**, **312** shown and described in reference to the previous figures. Although not shown, the door **105** shown in FIG. 3A can be used with the embodiment of FIGS. 6A–6E.

In operation inserting disk adapter cartridge **460** into a typical disk drive (such as the one shown in FIG. **3F**) allows for disk drive shutter actuator **470** (corresponding to the disk drive shutter actuator **170** of FIG. **3F**) to move in the direction of arrow **Z1**, abutting against the coin disk shutter actuator **480** (that moves in the direction of arrow **Z3**) having a through-hole opening **485** to catch about the raised pin **490** on the coin disk shutter **420**. Pin **490** slides downward in the direction of arrow **Z2** causing shutter **420** to pivot about center point **421** exposing magnetic media surface **412** of magnetic disk **410**.

FIG. **7A** is an enlarged exploded view **500** of a novel attachment device for the novel coin disk **10** of the preceding figures. FIG. **7B** shows the attachment device **500** of FIG. **7A** being used with a stack of papers **550**. Referring to FIGS. **7A-7B**, a novel attachment device can be formed from injection molded plastic and the like and includes raised arc sides **510** and **520** which tightly allow the side edges **22**, **26** of the coin disk to snap within when moved in the direction of arrow **M**. The arc sides **510** and **520** have respective bottom surface portions **515** and **525**. A bendable paper clip portion **530** movable downward in the direction of arrow **N** allows the attachment device **500** to attach to an edge of a stack of papers **550**, cardboard, clipboard, and the like.

Although the preferred embodiment can use the magnetic disks described in reference to the 3½ inch floppy disks having 1.44 MB described in reference to FIGS. **1A-1B**, the subject invention can use magnetic disks manufactured in accordance with recently introduced high memory capacity floppy disks. The coin disk of the subject invention can be manufactured with the technology used in the high-capacity 3½ inch floppy disks having a 200 MB (megabyte both sides) recording capacity such as the HiFD manufactured jointly by Sony Corp. and Fuji Photo Film Co. Mac Publications "HiFD to Support new, old floppies", MacWEEK News, Vol. 11 Issue 40, Oct. 17, 1997, pages 1-3. Additionally, the subject coin disk can be manufactured with the technology of the 3½ inch SuperDisk™ that have a 120 MB capacity manufactured by Imation Corporation. Imation Brochure Super Disk™ LS-120 Diskettes, 1997. Thus, the approximately 1 inch diameter magnetic coin disks using either the HiFD or SuperDisk™ technology would have greater capacity than the conventional standard 3½ inch floppy disks.

While the preferred embodiment has described using removable coin shaped magnetic memory disks, the invention can be applicable to other types of computer storage media such as but not limited to compact disks (CDs), and the like, where coin shaped compact disks can be used in place of the magnetic coin disks and have a higher density for storage.

While the invention has been described, disclosed, illustrated and shown in various terms of certain embodiments or modifications which it has presumed in practice, the scope of the invention is not intended to be, nor should it be deemed to be, limited thereby and such other modifications or embodiments as may be suggested by the teachings herein are particularly reserved especially as they fall within the breadth and scope of the claims here appended.

We claim:

1. An attachment device for a magnetic storage media disk, comprising:
 a coin shaped magnetic storage media disk;
 a coin shaped container slightly larger than the disk for receiving the disk therein, the coin shaped container

having a raised arc shaped side substantially covering an exterior perimeter of the coin-shaped container, the raised arc shaped side having a substantially arc shaped interior side which abuts against rounded edges of the coin disk, and a substantially arc shaped exterior side, the coin shaped container having a bottom surface portion for forming a backwall to the disk received in the container; and

a clip having an identical plane to the bottom surface portion, the clip has an upper end portion integrally connected to the bottom surface portion for forming a portion of the backwall to the disk, the clip having a lower end portion extending from the container and being bendable for attaching both the disk and the coin shaped container to a planar sheet.

2. The attachment device of claim **1**, wherein the coin shaped magnetic storage media disk includes:

a diameter of approximately one inch.

3. The attachment device of claim **1**, wherein the coin shaped container and the clip are formed from a single piece of plastic.

4. The attachment device of claim **1**, wherein the raised arc shaped side includes:

two raised arc shaped sides having a space therebetween, and the clip being located in the space between the two raised arc shaped sides.

5. An attachment device for a magnetic storage media disk, comprising in combination:

a coin shaped magnetic storage disk having a diameter of approximately one inch; and

a coin shaped container slightly larger than the coin disk, for snappingly receiving the disk, the coin shaped container including:

sidewalls having a rounded exterior surface and a rounded interior surface, the walls being slightly bendable for allowing the coin disk to be received therein;

a backwall attached to the side walls; and

a clip being in the same plane as the backwall, the clip having an upper portion having an upper end which is attached to the backwall, the clip having a lower portion that extends away from the coin-shaped container, the clip having a stationary position where substantially all of an upper surface of the clip abuts against the coin disk and a bendable position for attaching the coin shaped container to the planar sheet, so that a portion of the planar sheet is sandwiched between the backwall and the upper portion and the lower portion of the clip.

6. The attachment device of claim **5**, wherein the coin shaped container and the clip are formed from a single piece of plastic.

7. The attachment device of claim **5**, wherein the sidewalls further include:

two curved sidewalls having a space therebetween, and the clip is located in the space between the two curved sidewalls.

8. The attachment device of claim **5**, wherein the clip further includes:

a lower bendable end which extends away from the coin shaped container.