

STARS

University of Central Florida
STARS

UCF Patents

Technology Transfer

7-24-2001

Ferrofluid 3-D Gyroscope and Light Modulator.

Weili Luo

University of Central Florida

Tengda Du

University of Central Florida

Jie Huang

Michigan State University

Find similar works at: <https://stars.library.ucf.edu/patents>

University of Central Florida Libraries <http://library.ucf.edu>

This Patent is brought to you for free and open access by the Technology Transfer at STARS. It has been accepted for inclusion in UCF Patents by an authorized administrator of STARS. For more information, please contact STARS@ucf.edu.

Recommended Citation

Luo, Weili; Du, Tengda; and Huang, Jie, "Ferrofluid 3-D Gyroscope and Light Modulator." (2001). *UCF Patents*. 188.

<https://stars.library.ucf.edu/patents/188>





US006266146B1

(12) **United States Patent**
Luo et al.

(10) **Patent No.:** **US 6,266,146 B1**
(45) **Date of Patent:** **Jul. 24, 2001**

(54) **FERROFLUID 3-D GYROSCOPE AND LIGHT MODULATOR**

(75) Inventors: **Weili Luo**, Ovledo; **Tengda Du**, Orlando, both of FL (US); **Jie Huang**, East Lansing, MI (US)

(73) Assignee: **University of Central Florida**, Orlando, FL (US)

(*) Notice: Subject to any disclaimer, the term of this patent is extended or adjusted under 35 U.S.C. 154(b) by 0 days.

(21) Appl. No.: **09/454,473**

(22) Filed: **Dec. 3, 1999**

(51) **Int. Cl.**⁷ **G01B 9/02**

(52) **U.S. Cl.** **356/450; 356/521; 73/1.41**

(58) **Field of Search** **356/450, 459, 356/521; 73/1.38, 1.41; 250/231.12**

(56) **References Cited**

U.S. PATENT DOCUMENTS

3,354,311	11/1967	Vali et al. .	
3,639,063	2/1972	Krogstad et al. .	
3,930,729	1/1976	Gunn .	
4,011,044	3/1977	Uzgiris .	
4,086,808	5/1978	Camac et al. .	
4,656,421	4/1987	Ellis et al. .	
4,706,498	* 11/1987	Nemnich et al.	73/1.41
5,064,288	11/1991	Dyes et al. .	
5,555,086	9/1996	Vonbieren et al. .	
5,621,525	4/1997	Vogeler et al. .	
5,680,213	10/1997	Hunsaker et al. .	

OTHER PUBLICATIONS

Oai Thermal Lens Coupled Magneto–Optical Effect in a Ferrofluid, Tengda Du, Shihua Yuan, Weili Lou, American Institute of Physics, vol. 65, No. 14, Oct. 1994, pp 1844–1846.

Dynamic Interference Patterns from Ferrofluids, Tengda Du, Weili Luo, Modern Physics Letters, vol. 9, No. 25, Oct. 1995, pp 1643–1647.

Two Mechanisms and a Scaling Relation for Dynamics in Ferrofluids, Jinlong Zhang, C. Boyd, Weili Luo, *Physical Review Letters*, vol. 77, No. 2, Feb. 1996, pp 390–393.

Nonlinear Optical Effects in Ferrofluids Induced by Temperature and Concentration Cross Coupling, Tengda Du, Weili Luo, *Appl. Phys. Lett.*, vol. 72, No. 3, Jan. 1998, pp 272–274.

* cited by examiner

Primary Examiner—Samuel A. Turner

(74) *Attorney, Agent, or Firm*—Brian S. Steinberger; Law Offices of Brian S. Steinberger

(57) **ABSTRACT**

Apparatus and methods for passing a focused laser beam through a thin ferrofluid cell creates a spatial distribution in the refractive index of the ferrofluid and generates a diffraction ring patterns. Using a pair of perpendicularly placed ferrofluid cells, two sets of diffraction ring patterns can be produced on two viewing screens. Deformations in the diffraction patterns due to an acceleration can be viewed on the screens, providing a ferrofluid accelerometer. By applying an electric or a magnetic field on a thin ferrofluid sample, the light passing through the sample can be modulated by the field, providing a light modulator. The apparatus and method has applications for detecting acceleration information within a gyroscope and for use in toys.

18 Claims, 7 Drawing Sheets

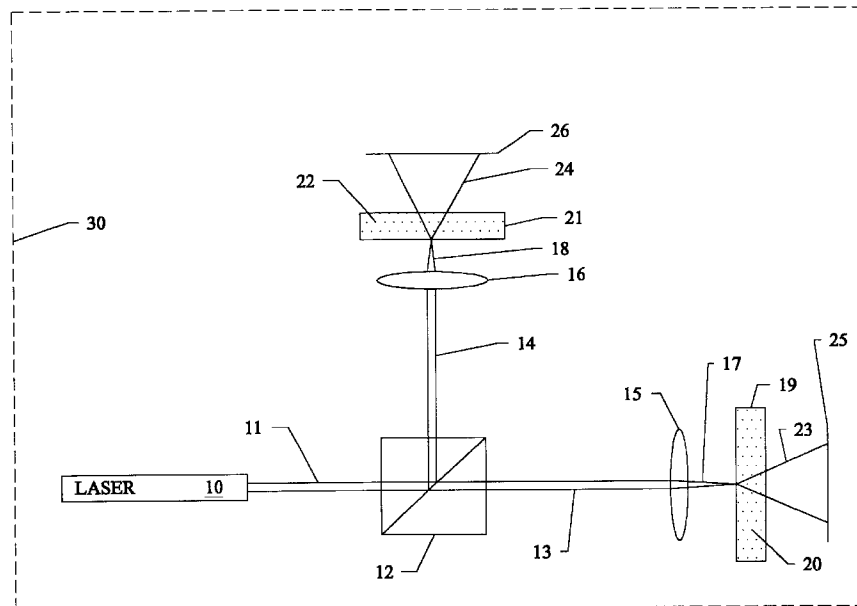

Fig. 1

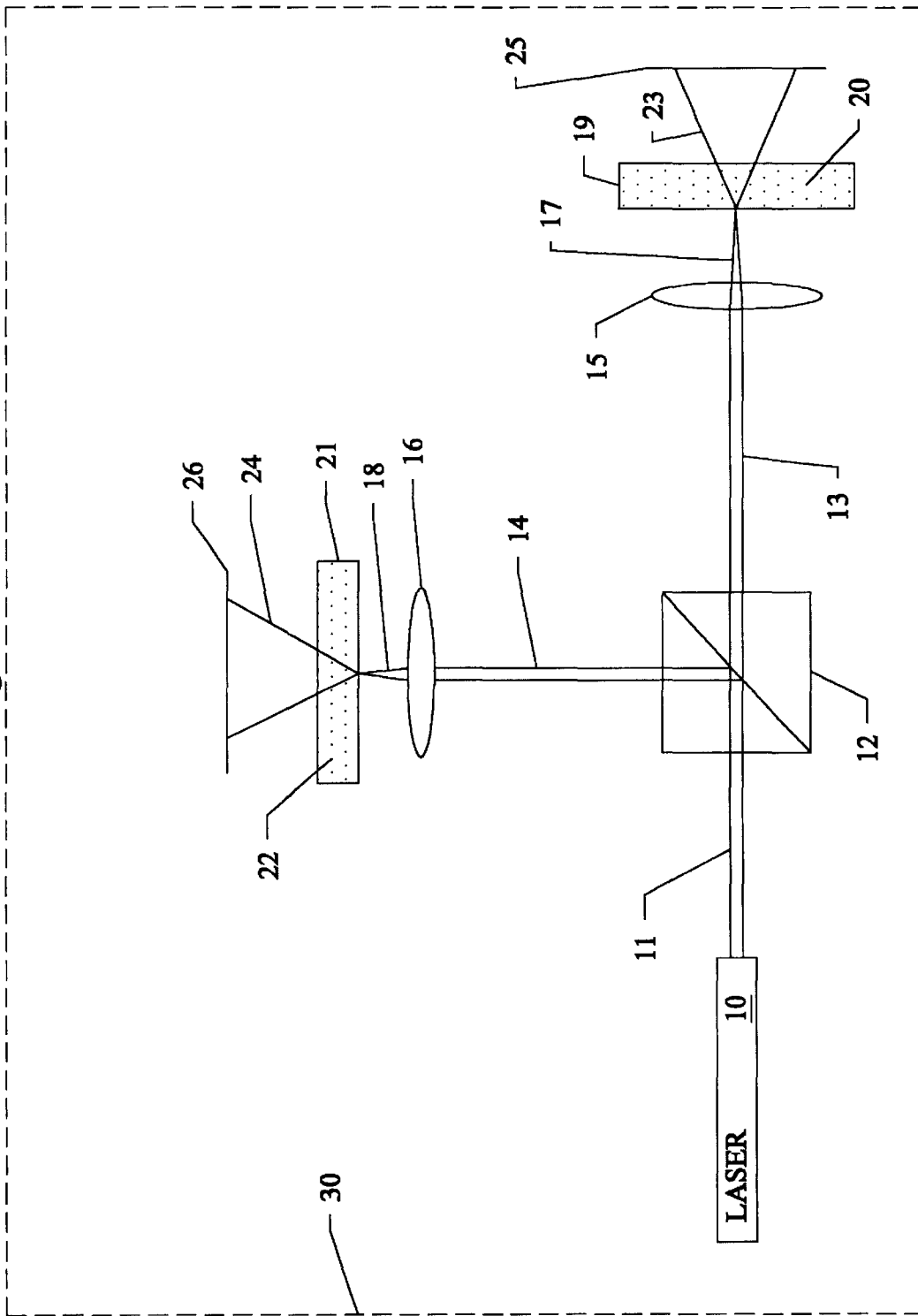

Fig. 2

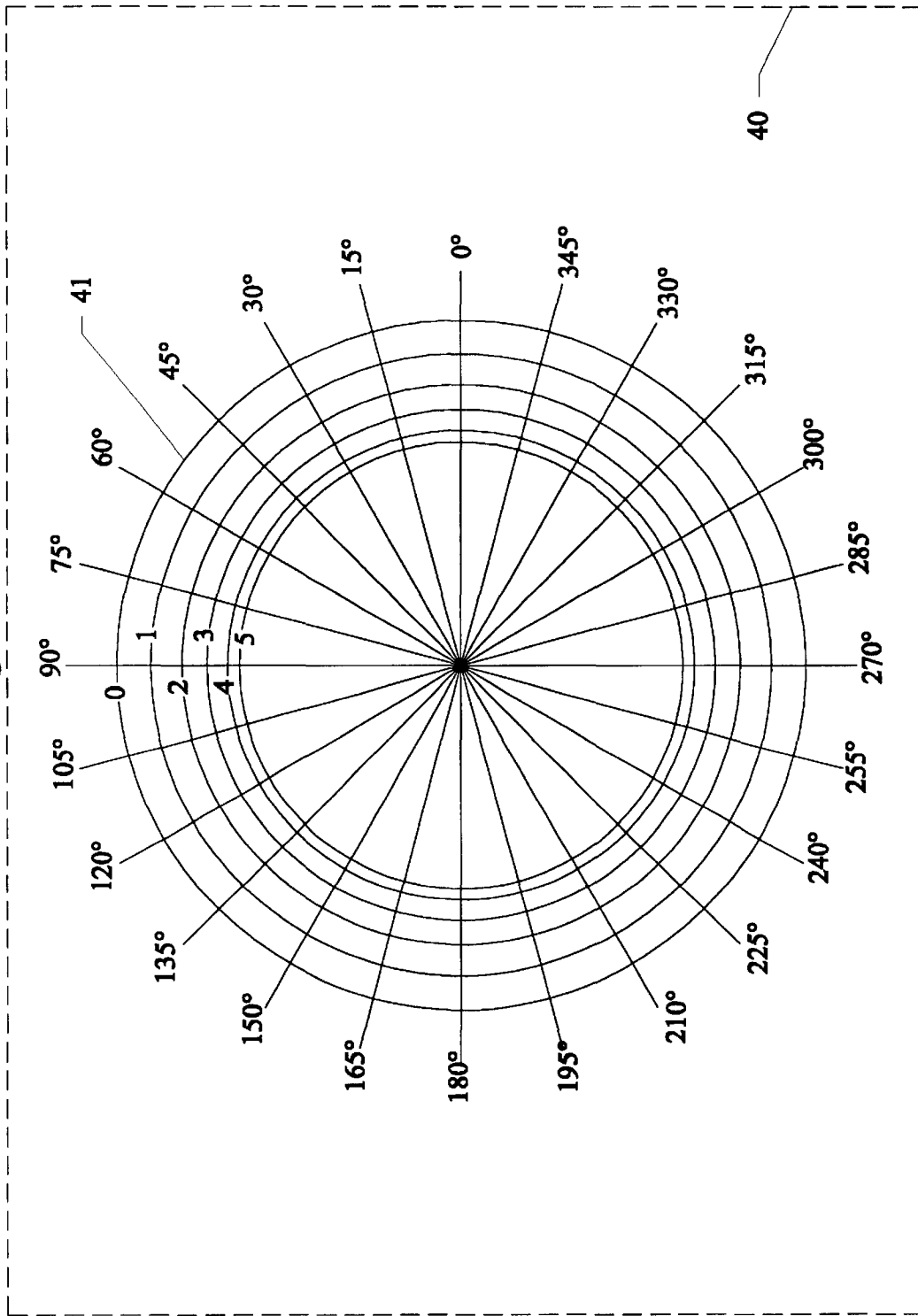

Fig. 3

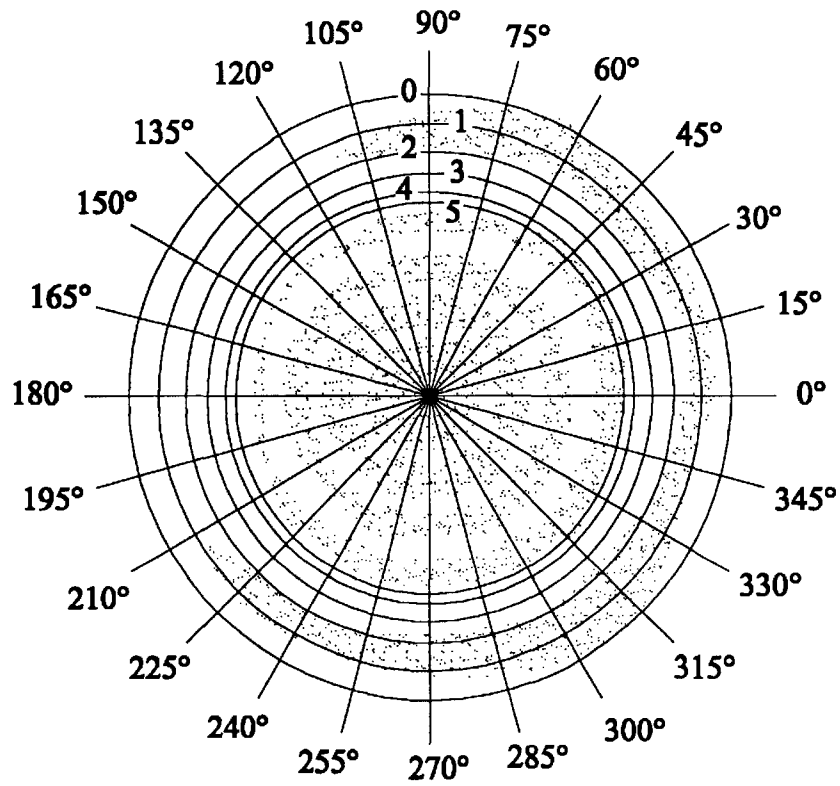
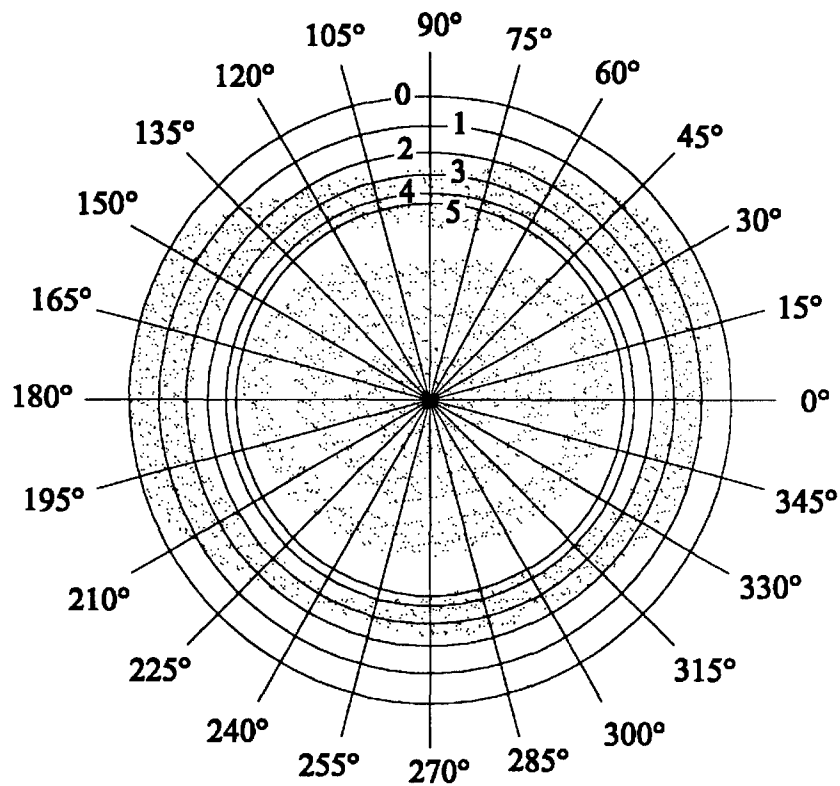

Fig. 4



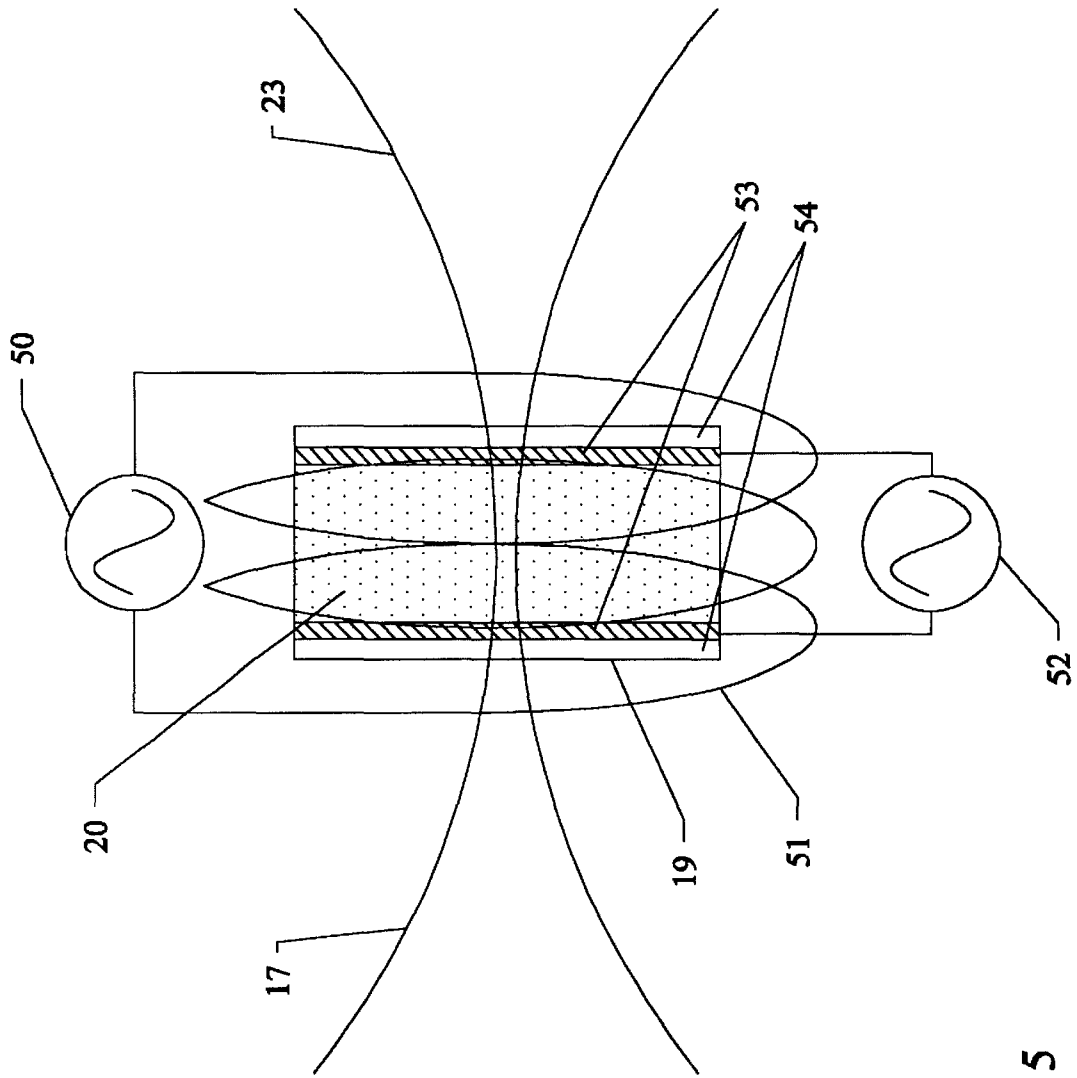

Fig. 5

Fig. 6

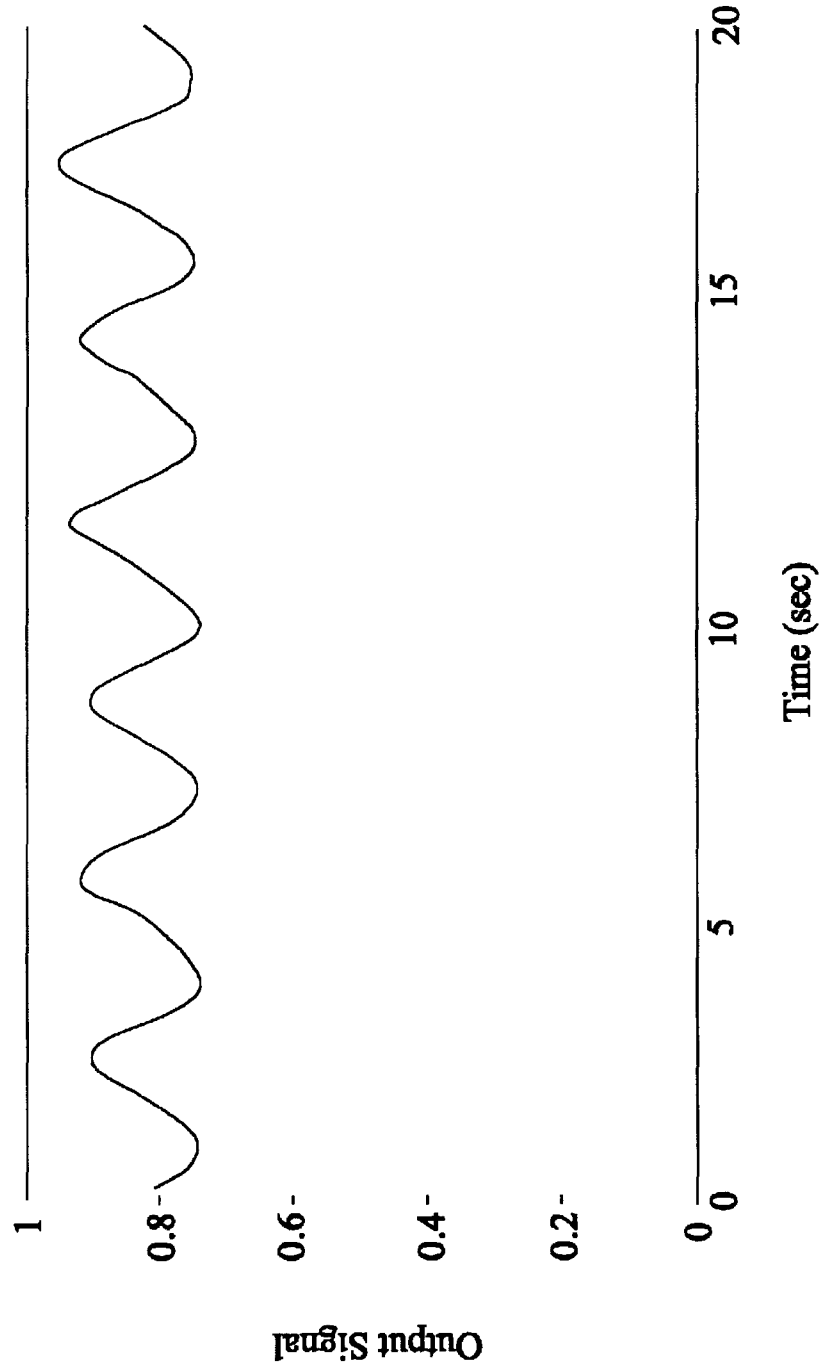

Fig. 7

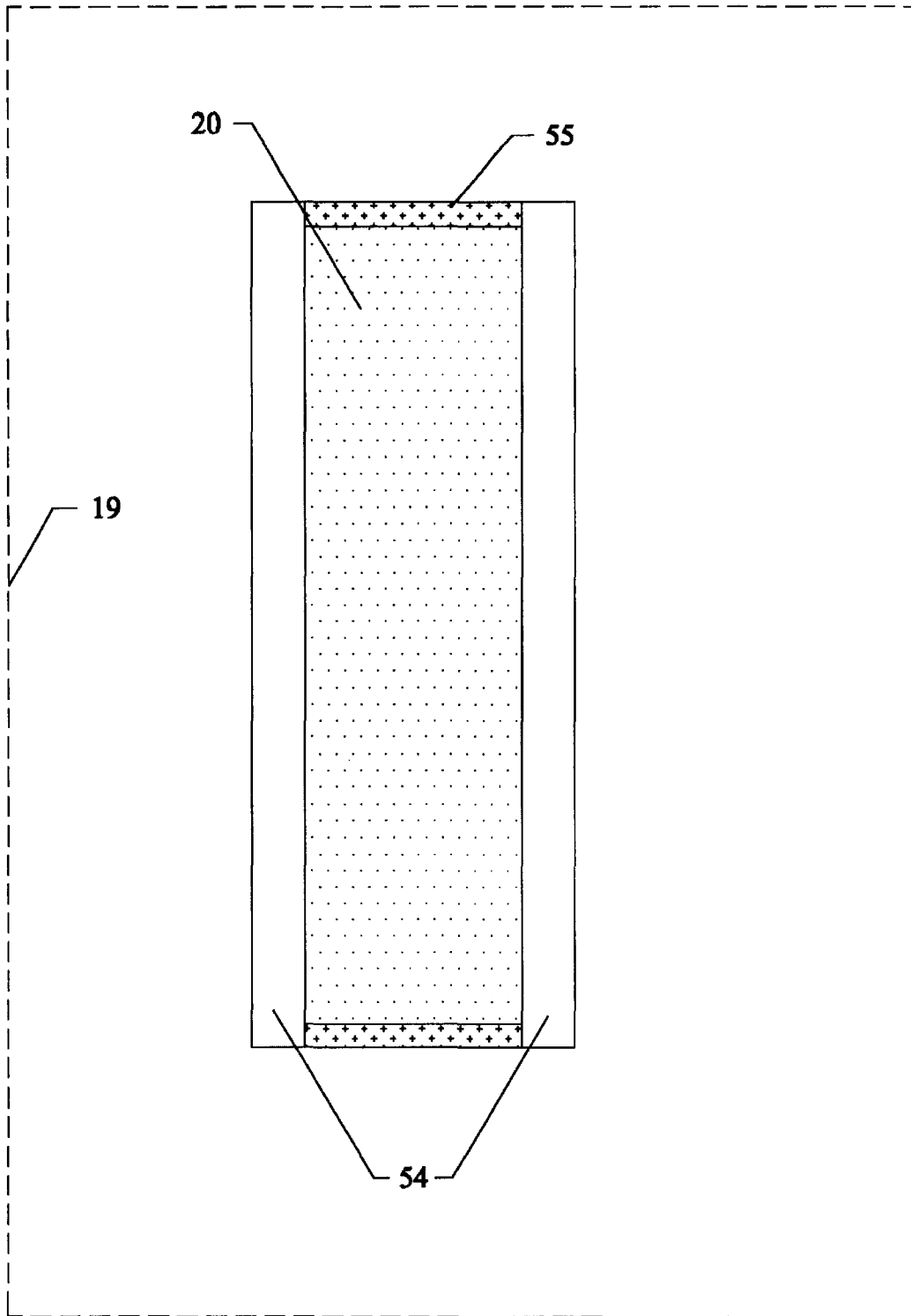
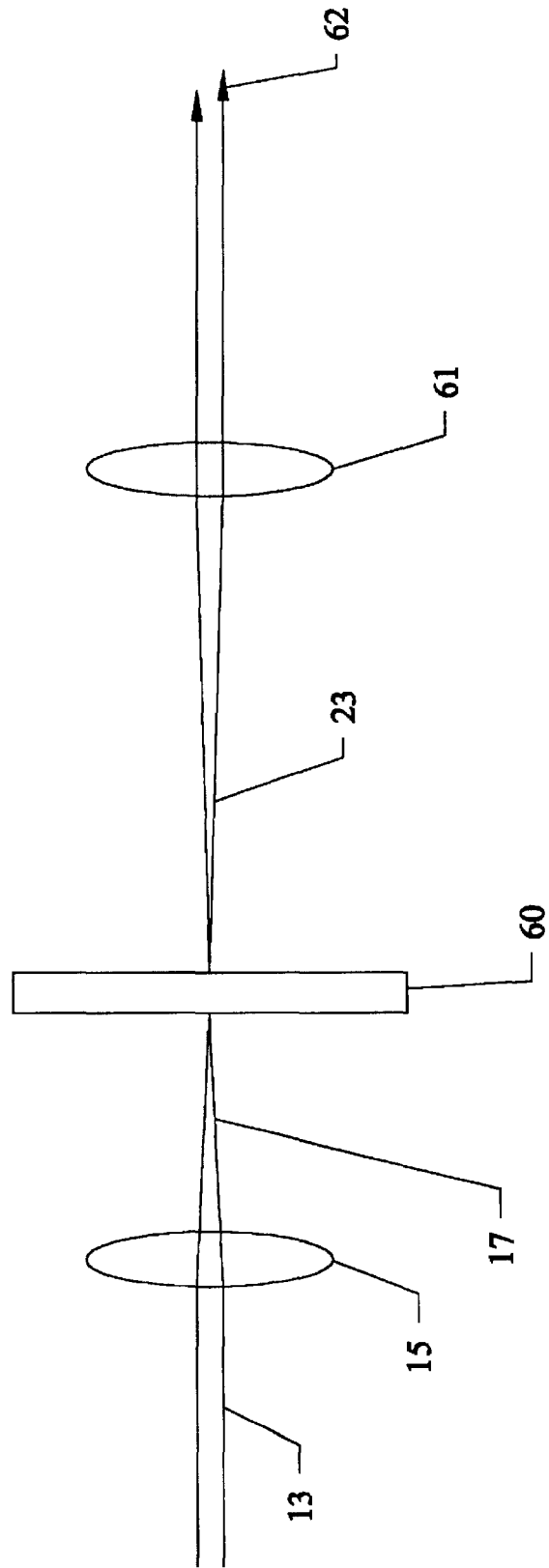

Fig. 8



FERROFLUID 3-D GYROSCOPE AND LIGHT MODULATOR

This invention relates to three-dimensional (3-D) acceleration detection and light modulation, and in specific to using two perpendicular laser beams focused on two ferrofluid cells to create two diffraction patterns whose deformations due to accelerations are used to visually display and detect the accelerations, and also using an electric or a magnetic field to modulate the intensity of light.

BACKGROUND AND PRIOR ART

Laser produced interference fringes from mechanical type mediums have been previously detected in order to extrapolate movement detection. See for example, U.S. Pat. No. 3,354,311 to Vali et al.; U.S. Pat. No. 3,639,063 to Krogstad et al.; and U.S. Pat. No. 4,086,808 to Camac.

Laser produced interference fringe patterns have also been observed through ferrofluids by two of the co-inventors of the subject invention. See for example, Du et al. "Thermal Lens coupled magneto-optical Effect in a Ferrfluid", Applied Physics Letters 65(14), Oct. 3, 1994, pp 1844-1846; Du et al. "Dynamic Interference Patterns From Ferrofluids", Modern Physics Letters 3, Vol. 9, No. 25(1995), pp.1643-1647; Zhang et al. "Two Mechanisms and a Scaling Relation for Dynamics in Ferrofluids", Physical Review Letters Vol. 77, No. 2, July 1996, pp. 390-393; and Du et al. "Nonlinear Optical Effects in Ferrofluids Induced by Temperature and Concentration Cross-Coupling", Applied Phys. Letters 72(3), January 1998, pp 272-274.

Interference fringe rings have been created by passing laser beams through liquid crystals in order to measure the power density of the laser beam. See U.S. Pat. No. 5,621,525 to Vogeler et al., which is assigned to the University of Central Florida, the assignee of the subject invention.

However, the cited art are generally limited to detection of fringes along a single x and y axis. None of the cited prior art allows for the detection of fringe patterns along all three dimensions (x,y,z) to be useful as gyroscopes and accelerometers.

SUMMARY OF THE INVENTION

A first object of the invention is to provide a simplified, low-cost means of visually displaying accelerations using fringe patterns generated through ferrofluid samples.

A second object of the invention is to provide a method of modulating light intensity with two independent control fields.

The third objective of the invention is to provide a simple technique to display gravity visually through the diffraction patterns generated from the ferrofluids, which could be used by aerospace industries and NASA.

The fourth objective of the invention is to produce educational toys based on the principles discussed in this invention.

This invention relates to three-dimensional (3-D) acceleration detection and light modulation. In specific, the invention uses two perpendicular laser beams focused on two ferrofluid cells to create two diffraction patterns whose deformations due to accelerations are used to visually display and detect the accelerations. The invention also utilizes an electric or a magnetic field to modulate the intensity of light.

In the absence of accelerations, the subject invention demonstrates that a focused laser beam perpendicularly

passing through a thin ferrofluid layer can generate concentric diffraction rings. The ferrofluid consists of magnetic particles suspended in kerosene. The strong light absorption of the particles causes nonuniform distributions in both temperature and particle concentration, yielding a spatial distribution in the index of refraction of the fluid around the beam and forming the observed rings. This diffraction pattern is visually observable by placing a viewing screen, which may simply comprise a piece of paper, a suitable distance away from the layer in the forward direction of the beam.

For a fluid with a nonuniform distribution in its mass density, an acceleration might cause a convective fluid flow within the fluid. If this fluid motion yields a measurable result, the result in turn can be used to determine the acceleration, providing a fluid-based accelerometer. The generated diffraction rings can be used to display the effect of an acceleration on the thin ferrofluid layer. The mass density of the fluid around the beam is nonuniform in the radial direction due to the inhomogeneous radial distributions in both temperature and concentration.

Accelerations perpendicular to the layer, do not cause convective motions within the fluid, and the concentric rings remain unchanged. However, an acceleration parallel to the layer causes a convective flow and deforms the rings. These deformed rings are easily visible to the eye, providing a qualitative and convenient means to visually display the acceleration. The measurement of the deformation in the rings can be used to determine the acceleration quantitatively, providing a method to measure accelerations when they are parallel to the layer. Since an acceleration can be decomposed into two accelerations perpendicular to each other and two perpendicularly placed ferrofluid cells can be used to display these two accelerations, an acceleration in any direction can be determined, providing a convenient 3-D ferrofluid accelerometer and gyroscope.

When an electric or a magnetic field is applied to a ferrofluid, the magnetic particles within the fluid have a strong interaction with the field, causing particles to move within the fluid. This interaction can be used to modulate the intensity of light passing through a ferrofluid sample.

Further objects and advantages of this invention will be apparent from the following detailed description of a presently preferred embodiment which is illustrated schematically in the accompanying drawings.

BRIEF DESCRIPTION OF THE FIGURES

FIG. 1 is a side view schematic illustration of a ferrofluid accelerometer of the invention.

FIG. 2 shows a viewing screen with a calibrated scale shown in the apparatus of FIG. 1.

FIG. 3 is the diffraction pattern without accelerations produced on a viewing screen shown in the apparatus of FIG. 1.

FIG. 4 is the diffraction pattern with an acceleration produced on a viewing screen shown in the apparatus of FIG. 1.

FIG. 5 is a schematic illustration of a ferrofluid light modulator.

FIG. 6 shows the modulated intensity of a light.

FIG. 7 shows a ferrofluid gyroscope of the invention.

FIG. 8 shows a light modulator of FIG. 7.

DESCRIPTION OF THE PREFERRED EMBODIMENT

Before explaining the disclosed embodiment of the present invention in detail it is to be understood that the

invention is not limited in its application to the details of the particular arrangement shown since the invention is capable of other embodiments. Also, the terminology used herein is for the purpose of description and not of limitation.

A system for optically detecting accelerations is illustrated in FIG. 1. The system comprises a pair of ferrofluid cells **19** and **21** fabricated of a light-transmissive, fluid-impenetrable material, such as glass, plastic or the like. FIG. 5 shows that the cell **19** can be used as a light modulator. FIG. 7 shows the cell **19** is used in a 3-D gyroscope as a separated cell. When used as a gyroscope, the AC current source **50**, AC voltage source **52**, Magnetic coil **51** are not used, and the cell is not coated with conducting layers **53**.

Referring to FIG. 1, the thickness of each of the cells **19**, **20** is approximately 100 μm and the dimension is $2 \times 2 \text{ cm}^2$. They are filled with ferrofluid **20** and **22**. The ferrofluid consists of magnetite particles (volume fraction 6%) suspended in kerosene. The mean diameter of each particle is 9 nm and each particle is coated with a non-magnetic surfactant layer (such as oleic acid) of 2 nm in thickness to prevent agglomeration.

FIG. 1 schematically illustrates a ferrofluid accelerometer **30** that includes a laser light source **10** such as a He-Ne laser **10** with a power of 8 mW which produces a beam **11** having a wavelength of approximately 632.8 nm. FIG. 1 further includes a half reflection and half transmission beam splitter **12**, a pair of single piece convex lenses **15** and **16**, two thin ferrofluid cells **19** and **21**, and a pair of viewing screens **25** and **26** with a calibrated scale.

The viewing screen with calibrated scale is shown in FIG. 2. The viewing screen is specifically designed for visual-display purpose instead of using computers. As mentioned in the description of FIG. 2, the concentric circles are the scales for magnitude of accelerations and the radial lines are for their direction. FIG. 3 and FIG. 4 are two examples for measuring accelerations.

Referring to FIG. 1, beam splitter **12** splits beam **11** into two beams, beam **13** and beam **14**. Lens **15** focuses beam **13** on ferrofluid cell **19**, and lens **16** focuses beam **14** on ferrofluid cell **21**. Focused beam **17** creates a spatial distribution in the refractive index of ferrofluid **20** and generates diffraction pattern **23** displayed on viewing screen **25**. Similarly, focused beam **18** creates a spatial distribution in the refractive index of ferrofluid **22** and generates diffraction pattern **24** displayed on viewing screen **26**. As previously mentioned, acceleration can be determined by viewing the patterns on the calibrated scale **40**, and can be done manually or by computer.

FIG. 2 shows a viewing screen **40** with a calibrated scale **41**. Scales **41** consists a set of concentric circles corresponding to accelerations 0, 1, 2, 3, 4, and 5 m/s^2 calibrated with our experimental data.

FIG. 3 is a photographic reproduction of the diffraction pattern in the absence of accelerations produced on a viewing screen shown in the apparatus of FIG. 1. As can be seen clearly, these diffraction rings are not distorted. The most outside pink ring is chosen as the reference ring.

FIG. 4 is a photographic reproduction of a deformed diffraction pattern due to the effect of an acceleration produced on a viewing screen shown in the apparatus of FIG. 1. Deformation in the diffraction rings is clearly shown. The acceleration is in the direction of 270 degrees and has a magnitude of 5 m/s^2 .

If there is no acceleration, the diffraction rings are perfect circles as shown in FIG. 3. If there is an acceleration the diffraction pattern will deform. The deformation will occur

in the direction of acceleration. Specifically the upper part which is opposite to the direction of acceleration is compressed, and the lower part which is parallel to the direction of acceleration is elongated. Therefore we can determine the direction of acceleration by finding the elongation direction of the pattern. The magnitude of acceleration can be evaluated by observing the reference ring (compressed of outmost ring) which aligns the calibrated scale. FIG. 4 shows the compressed part aligns with a scale circle labeled "5", we say the magnitude of acceleration is 5 m/s^2 . The elongation direction is in 270 degrees radical direction, so is the direction of the acceleration.

Referring to FIG. 1, screen **25** is an X-Y plane and screen **26** is an Y-Z plane. With the method described above we can separately determine the X components by view screen **25**, the Z component by viewing screen **26**, and Y component by viewing either screen **25** or screen **26** or taking the average of both. The acceleration in X, Y, Z direction can then be calculated.

FIG. 5 schematically illustrates a light modulator. The ferrofluid cell **19** is modified by coating electrically conducting layers **53** on the inner sides of the two glass plates **54**, and an AC voltage source **52** is supplied on the two conducting layers **53**. A magnetic coil **51** is connected with an AC current source **50**, providing an AC magnetic field on the ferrofluid **20**.

The light modulator can be used to modulate a laser with a constant input power to output an ac power with certain frequency. It can use one of the two branches in FIG. 1. The output power can be modulated with a certain frequency, which is doubled from that of magnetic or electric field as shown in FIG. 6.

FIG. 6 shows the modulated light intensity when an AC magnetic field is applied to the sample. Without the applied field, the light intensity is a constant. The applied field modulates the light varying with time shown. The amplitude of the field is 13 Oe and the frequency 0.2 Hz. Gravity and other accelerations have strong effect on these diffraction rings, and the distorted rings could be used to visually display these effects for education or toys. A small magnet could also change the concentric rings to many different patterns, which in turn could be used to make toys, showing magnet induced dynamic patterns.

FIG. 7 shows a schematic for a ferrofluid cell 19/21 gyroscope shown in the apparatus of FIG. 1. A ferrofluid **20** is sandwiched between two glass plates **54** separated by a spacer **55** with the thickness of 100 μm .

FIG. 8. shows the light modulator of FIG. 7 with other optical components. The incident laser beam **13** is focused by lens **15**. After passing through a light modulator, the output power of beam **23** is modulated by ac field. The beam **23** can be further collimated by lens **61** and becomes beam **62**.

While the invention has been described, disclosed, illustrated and shown in various terms of certain embodiments or modifications which it has presumed in practice, the scope of the invention is not intended to be, nor should it be deemed to be, limited thereby and such other modifications or embodiments as may be suggested by the teachings herein are particularly reserved especially as they fall within the breadth and scope of the claims here appended.

We claim:

1. A method for detecting acceleration information from diffraction ring patterns in ferrofluids, comprising the steps of:

5

emitting a first light beam and a second light beam;
 passing the first light beam through a first ferrofluid cell
 to produce a first set of diffraction ring patterns;
 passing the second light beam through a second ferrofluid
 cell to produce a second set of diffraction ring patterns;
 and
 detecting acceleration information from the first set of
 diffraction ring patterns and the second set of diffraction
 ring patterns.

2. The method for detecting acceleration information of
 claim 1, wherein axes of the first ferrofluid cell and the
 second ferrofluid cell are oriented perpendicular to one
 another.

3. The method for detecting acceleration information of
 claim 1, wherein the emitting step includes:

a laser beam source.

4. The method for detecting acceleration information of
 claim 1, wherein the emitting step includes:

a beam splitter.

5. The method for detecting acceleration information of
 claim 1, wherein the first set of diffraction ring patterns and
 the second set of diffraction ring patterns each includes:

concentric rings.

6. The method for detecting acceleration information of
 claim 1, wherein the detecting step further includes:

visually displaying optical changes in diffraction patterns
 on a scale.

7. The method for detecting acceleration information of
 claim 6, wherein the scale includes:

concentric circles having acceleration calibrations units.

8. The method for detecting acceleration information of
 claim 1, further comprising the step of:

modulating light passing through at least one of the first
 ferrofluid cell and the second ferrofluid cell.

9. The method for detecting acceleration information of
 claim 8, wherein the modulating step includes a field chosen
 from at least one of:

an electric field and a magnetic field.

10. An apparatus for passing a first light beam through a
 first ferrofluid cell to produce a first set of diffraction ring
 patterns;

6

means for emitting a first light beam and a second light
 beam;
 a first ferrofluid for passing the first light beam there-
 through to produce a first set of diffraction ring pat-
 terns;
 a second ferrofluid for passing the second light beam
 therethrough to produce a second set of diffraction ring
 patterns; and
 means for detecting acceleration information from the
 first set of diffraction ring patterns and the second set of
 diffraction ring patterns.

11. The apparatus for detecting acceleration information
 of claim 10, wherein axes of the first ferrofluid cell and the
 second ferrofluid cell are oriented perpendicular to one
 another.

12. The apparatus for detecting acceleration information
 of claim 10, wherein the emitting means includes:

a laser beam source.

13. The apparatus for detecting acceleration information
 of claim 10, wherein the emitting means includes:

a beam splitter.

14. The apparatus for detecting acceleration information
 of claim 10, wherein the first set of diffraction ring patterns
 and the second set of diffraction ring patterns each includes:

concentric rings.

15. The apparatus for detecting acceleration information
 of claim 10, wherein the detecting means further includes:

display means for visually displaying optical changes in
 diffraction patterns on a scale.

16. The apparatus for detecting acceleration information
 of claim 15, wherein the scale includes:

concentric circles having acceleration calibrations units.

17. The apparatus for detecting acceleration information
 of claim 10, further comprising:

means for modulating light passing through at least one of
 the first ferrofluid cell and the second ferrofluid cell.

18. The apparatus for detecting acceleration information
 of claim 17, wherein the modulating means includes a field
 chosen from at least one of:

an electric field and a magnetic field.

* * * * *

UNITED STATES PATENT AND TRADEMARK OFFICE
CERTIFICATE OF CORRECTION

PATENT NO. : 6,266,146 B1
APPLICATION NO. : 09/454473
DATED : July 24, 2001
INVENTOR(S) : Weili Luo

Page 1 of 1

It is certified that error appears in the above-identified patent and that said Letters Patent is hereby corrected as shown below:

Col. 1, lines 11-12 should read,

STATEMENT REGARDING FEDERALLY SPONSORED RESEARCH OR DEVELOPMENT

This subject invention was made with government support under the National Science Foundation, federal contract number DMR0072901. The government has certain rights in this invention.

Signed and Sealed this
Eighth Day of March, 2011

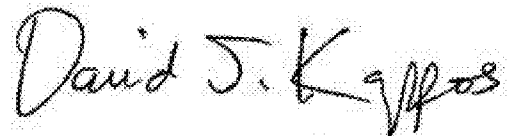
A handwritten signature in black ink that reads "David J. Kappos". The signature is written in a cursive style with a large initial "D" and "K".

David J. Kappos
Director of the United States Patent and Trademark Office