

STARS

University of Central Florida
STARS

UCF Patents

Technology Transfer

9-14-2004

Target Steering System for EUV Droplet Generators

Steven Fornaca
Northrop Grumman Corporation

Rocco Orsini
Northrop Grumman Corporation

Michael Petach
Northrup Grumman Corporation

Find similar works at: <https://stars.library.ucf.edu/patents>
University of Central Florida Libraries <http://library.ucf.edu>

This Patent is brought to you for free and open access by the Technology Transfer at STARS. It has been accepted for inclusion in UCF Patents by an authorized administrator of STARS. For more information, please contact STARS@ucf.edu.

Recommended Citation

Fornaca, Steven; Orsini, Rocco; and Petach, Michael, "Target Steering System for EUV Droplet Generators" (2004). *UCF Patents*. 790.
<https://stars.library.ucf.edu/patents/790>





(12) **United States Patent**
Petach et al.

(10) **Patent No.:** **US 6,792,076 B2**
(45) **Date of Patent:** **Sep. 14, 2004**

(54) **TARGET STEERING SYSTEM FOR EUV DROPLET GENERATORS**

(75) Inventors: **Michael B. Petach**, Redondo Beach, CA (US); **Steven W. Fornaca**, Torrance, CA (US); **Rocco A. Orsini**, Long Beach, CA (US)

(73) Assignee: **Northrop Grumman Corporation**, Redondo Beach, CA (US)

(*) Notice: Subject to any disclaimer, the term of this patent is extended or adjusted under 35 U.S.C. 154(b) by 47 days.

(21) Appl. No.: **10/157,222**

(22) Filed: **May 28, 2002**

(65) **Prior Publication Data**

US 2003/0223541 A1 Dec. 4, 2003

(51) **Int. Cl.**⁷ **H01J 35/00**

(52) **U.S. Cl.** **378/119; 378/143**

(58) **Field of Search** **378/119, 143**

(56) **References Cited**

U.S. PATENT DOCUMENTS

4,723,262 A	2/1988	Noda et al.	378/119
5,577,091 A *	11/1996	Richardson et al.	378/119
5,577,092 A	11/1996	Kublak et al.	378/119
6,002,744 A	12/1999	Hertz et al.	378/119
6,324,256 B1	11/2001	McGregor et al.	378/119
6,377,651 B1	4/2002	Richardson et al.	378/34

OTHER PUBLICATIONS

Rymell, L., Berglund, M., Hansson, B.A.M. & Hertz, H.M., "X-ray and EUV laser-plasma sources based on cryogenic liquid-jet target", SPIE vol. 3676, Mar. 1999, pp. 421-424.
Gouge, M.J. & Fisher, P.W., "A cryogenic xenon droplet generator for use in a compact laser plasma x-ray source", Rev. Sci. Instrum., vol. 68, No. 5, May 1997, pp. 2158-2162.

Torres, D., Jin, F., Richardson, M. & DePriest, C., "Characterization of mass-limited ice droplet laser plasmas", OSA Trends in Optics and Photonics, vol. IV, Extreme Ultraviolet Lithography, 1996, pp. 75-79.

Malmquist, L., Rymell, L. & Hertz, H.M., "High-repetition-rate droplet target for laser-plasma EUV generation", OSA Trends in Optics and Photonics, vol. IV, Extreme Ultraviolet Lithography, 1996, pp. 72-74.

Jin, F., Richardson, M.C., Shimkaveg, G.M. and Torres, D., "Characterization of a Laser Plasma Water Droplet EUV Source", Proceedings of SPEI, vol. 2523, 1995, pp. 81-87.

Rymell, L. and Hertz, H.M., "Droplet Target for Low-debris Laser-plasma Soft X-ray Generation", Optics Communications, vol. 103, 1993, pp. 105-110.

Heinzel, J. and Hertz, C.H., "Ink-jet Printing", Advances in Electronics and Electron Physics, Ed. by P.W. Hawkes, vol. 65, 1985, pp. 91-141.

Tanimoto, M., "Cryogenic Experimental Device for Production of Solid Pellets", Proceedings of 7th Symposium on Fusion Technology, Grenoble, 1972.

European Search Report re: counterpart application No. EP 03 01 1056.

* cited by examiner

Primary Examiner—Craig E Church

Assistant Examiner—Jurie Yun

(74) *Attorney, Agent, or Firm*—Harness, Dickey & Pierce, P.L.C.

(57) **ABSTRACT**

An EUV radiation source (50) that employs a steering device (74) for steering a stream (66) of droplets (68) generated by a droplet generator (52) so that the droplet (68) are directed towards a target location (76) to be vaporized by a laser beam (78). The direction of the stream (66) of droplets (68) is sensed by a sensing device (84). The sensing device (84) sends a signal to an actuator (88) that controls the orientation of the steering device (74) so that the droplets (68) are directed to the target location (76).

18 Claims, 1 Drawing Sheet

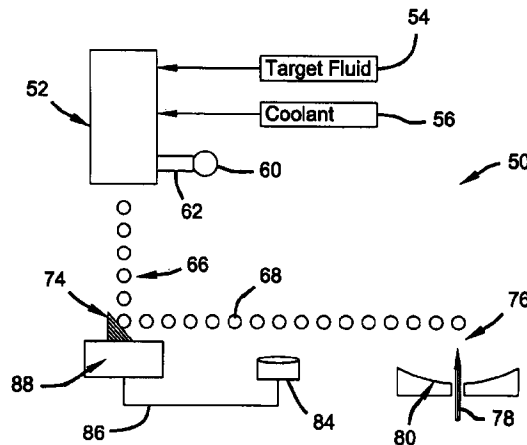

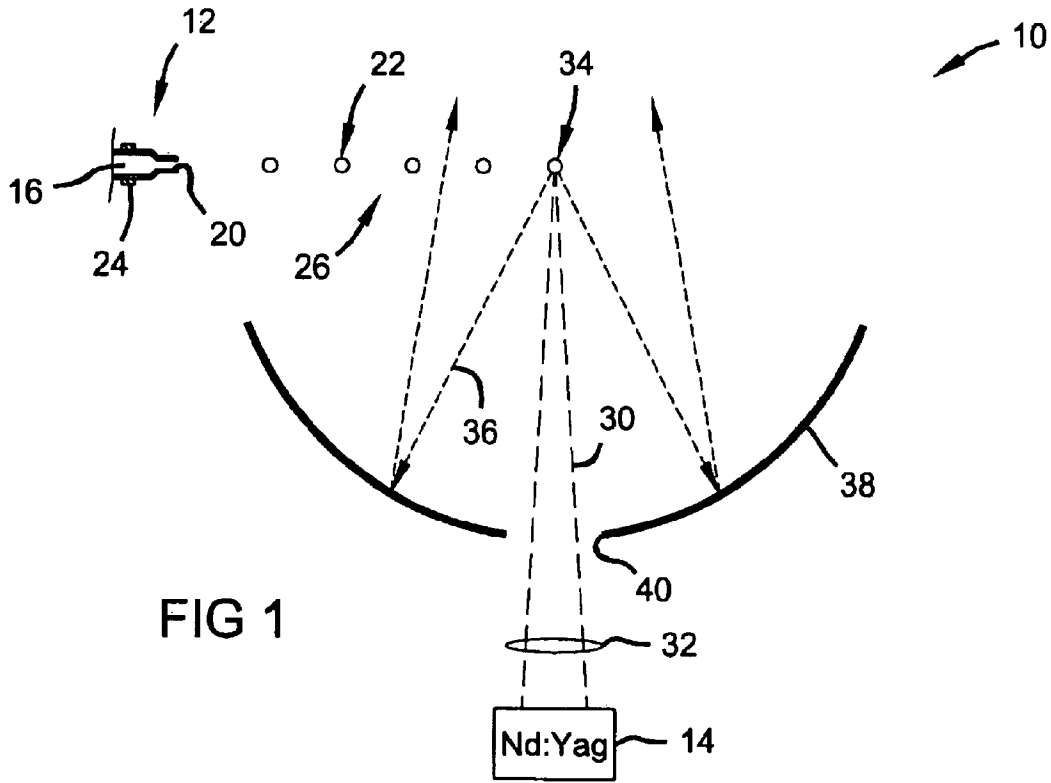

FIG 1

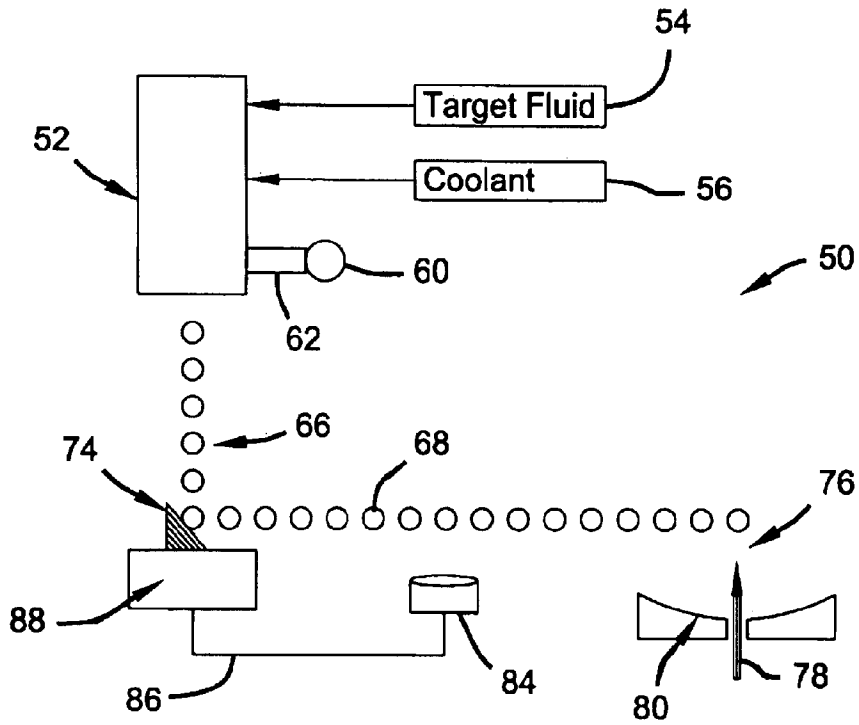

FIG 2

TARGET STEERING SYSTEM FOR EUV DROPLET GENERATORS

BACKGROUND OF THE INVENTION

1. Field of the Invention

This invention relates generally to an EUV radiation source and, more particularly, to an EUV radiation source that employs a target steering device to accurately steer the target droplets to the target vaporization area.

2. Discussion of the Related Art

Microelectronic integrated circuits are typically patterned on a substrate by a photolithography process, well known to those skilled in the art, where the circuit elements are defined by a light beam propagating through a mask. As the state of the art of the photolithography process and integrated circuit architecture becomes more developed, the circuit elements become smaller and more closely spaced together. As the circuit elements become smaller, it is necessary to employ photolithography light sources that generate light beams having shorter wavelengths and higher frequencies. In other words, the resolution of the photolithography process increases as the wavelength of the light source decreases to allow smaller integrated circuit elements to be defined. The current state of the art for photolithography light sources generate light in the extreme ultraviolet (EUV) or soft x-ray wavelengths (13–14 nm).

U.S. patent application Ser. No. 09/644,589, filed Aug. 23, 2000, entitled “Liquid Sprays as a Target for a Laser-Plasma Extreme Ultraviolet Light Source,” and assigned to the assignee of this application, discloses a laser-plasma, EUV radiation source for a photolithography system that employs a liquid as the target material, typically xenon, for generating the laser plasma. A xenon target material provides the desirable EUV wavelengths, and the resulting evaporated xenon gas is chemically inert and is easily pumped out by the source vacuum system. Other liquids and gases, such as krypton and argon, and combinations of liquids and gases, are also available for the laser target material to generate EUV radiation.

The EUV radiation source employs a source nozzle that generates a stream of target droplets. The droplet stream is created by forcing a liquid target material through an orifice (50–100 microns diameter), and perturbing the flow by voltage pulses from an excitation source, such as a piezoelectric transducer, attached to a nozzle delivery tube. Typically, the droplets are produced at a high rate (10–100 kHz) at the Rayleigh instability break-up frequency of a continuous flow stream. The droplets may be emitted from the nozzle into a vacuum, where rapid evaporation and freezing of the droplets will result, or they may be ejected into a buffer gas at an appropriate pressure and temperature to control the rate of evaporation of the droplets.

To meet the EUV power and dose control requirements for next generation commercial semiconductors manufactured using EUV photolithography, the laser beam source must be pulsed at a high rate, typically 5–10 kHz. It therefore becomes necessary to supply high-density droplet targets having a quick recovery of the droplet stream between laser pulses, such that all laser pulses interact with target droplets under optimum conditions. This requires a droplet generator which produces droplets within 100 microseconds of each laser pulse.

Droplet generators, including downstream differentially pumped cavities, are relatively massive and employ many

connections for coolant, vacuum and electrical lines. Thus, weight and configuration constraints make the droplet generator difficult to position, and consequently severely limits its positioning response time. Further, the orientation of the droplet generator relative to the target location may be required to be off axis.

SUMMARY OF THE INVENTION

In accordance with the teachings of the present invention, an EUV radiation source is disclosed that employs a steering device for steering a droplet stream generated by a droplet generator to a target area. The droplet generator directs the stream of droplets in a certain direction that is sensed by a position sensor. The sensed position of the droplet stream is sent to an actuator that controls the orientation of the steering device. The droplet stream impinges the steering plate and is deflected therefrom towards the target area.

Additional objects, advantages and features of the present invention will become apparent from the following description and appended claims, taken in conjunction with the accompanying drawings.

BRIEF DESCRIPTION OF THE DRAWINGS

FIG. 1 is a plan view of an EUV radiation source; and FIG. 2 is another plan view of an EUV radiation source employing a droplet stream steering plate, according to an embodiment of the present invention.

DETAILED DISCUSSION OF THE EMBODIMENTS

The following discussion of the embodiments of the invention directed to an EUV radiation source employing a steering plate is merely exemplary in nature, and is in no way intended to limit the invention or its applications or uses.

FIG. 1 is a plan view of an EUV radiation source 10 including a nozzle 12 and a laser beam source 14. A liquid 16, such as xenon, flows through the nozzle 12 from a suitable source. The liquid 16 is forced under pressure through an exit orifice 20 of the nozzle 12 where it is formed into a stream 26 of liquid droplets 22 directed to a target location 34. A piezoelectric transducer 24 positioned on the nozzle 12 perturbs the flow of liquid 16 to generate the droplets 22.

A laser beam 30 from the source 14 is focused by focusing optics 32 onto the droplet 22 at the target location 34, where the source 14 is pulsed relative to the rate of the droplets 22 as they reach the target location 34. The heat from the laser beam 30 vaporizes the droplet 22 and generates a plasma that radiates EUV radiation 36. The EUV radiation 36 is collected by collector optics 38 and is directed to the circuit (not shown) being patterned. The collector optics 38 can have any suitable shape for the purposes of collecting and directing the radiation 36. In this design, the laser beam 30 propagates through an opening 40 in the collector optics 38, however, other designs employ different collector optics designs. The plasma generation process is performed in a vacuum.

The orientation of the nozzle 12 relative to the target location 34 is provided in the radiation source 10 so that the stream 26 of droplets 22 are directed straight to the target location 34. However, in practical systems, it is difficult to orient the nozzle 12 relative to the collector optics 38 so that the droplets 22 are directed exactly to the target location 34. Further, system operating parameters sometimes cause the

droplets **22** to be emitted from the nozzle **12** along slightly different paths. Further, in some designs, the orientation of the nozzle relative to the target location is specifically designed to be off-axis.

FIG. **2** is a plan view of an EUV radiation source **50**, according to an embodiment of the present invention. The source **50** includes a droplet generator **52** that receives a target material, such as liquid xenon, from a source **54**. The nozzle **12** discussed above would be the type of nozzle provided within the droplet generator **52** to generate the droplets. The droplet generator **52** is shown generally because its specific configuration is not important to the present invention, and thus is intended to represent any droplet generator suitable for the purposes described herein.

Because the target material is typically a gas at room temperature and pressure, the target material is chilled, for example, by liquid nitrogen, to put it in the liquid state. A coolant from a coolant source **56** is applied to the droplet generator **52** to maintain the target material in the liquid state within the generator **52**. Further, the droplet generator **52** is maintained in a vacuum to limit the gases which may interact with the droplet formation process. A pump **60** is connected to a pump output port **62** of the generator **52** so that gases within the generator **52** can be removed.

The droplet generator **52** generates a stream **66** of droplets **68**. The droplets **68** have a predetermined spacing and size for the EUV radiation generation process, as would be well understood to those skilled in the art. As discussed above, the droplets **68** are emitted into a vacuum, or a low pressure chamber, where the droplets **68** begin to evaporate, condense and freeze to the desirable size.

In this example, the stream **66** is directed from the droplet generator **52** off-axis relative to the source target location. In order to redirect the stream **66** so it is properly oriented relative to the target location, a reflective steering plate **74** is provided, according to the invention. The steering plate **74** can be any suitable reflective surface or device that causes the droplets **68** to be deflected therefrom. By the time the droplets **68** reach the steering plate **74**, they are substantially frozen as a result of their low temperature and the low pressure source environment so that the droplets **68** are easily deflected therefrom.

In this example, the steering plate **74** is positioned so that the stream **66** and the droplets **68** are deflected substantially 90° from their original path. The stream **66** is redirected by the steering plate **74** so that the droplets **68** pass through a target location **76**, where a laser beam **78** strikes the target droplet **68** as it enters the target location **76**. Further, the target location **76** is at the focal point of primary collecting optics **80**.

To determine that the stream **66** is directed to the target location **76**, a position sensor **84** is located at a strategic location along the stream **66**. Any type of sensor capable of sensing frozen droplets and suitable for an EUV radiation source can be used. The sensor **84** sends an electrical signal on line **86** back to a steering plate actuator **88** that adjusts the orientation of a steering plate **74** so that the direction of the stream **66** is corrected. Thus, the position sensor **84** senses whether the droplets **68** are in the proper line relative to the target location **76**. Although not particularly shown, known EUV radiation sources employ detectors that determine whether the droplets **68** are being vaporized properly at the desirable location. Therefore, the system would include feedback to insure that the droplets **68** are being directed to the target location **76**.

The position of the sensor **84** is shown at a location after the stream **66** has been deflected by the steering plate **74**.

However, this is by way of a non-limiting example, in that the sensor **84** can be positioned at any convenient location along the path of the stream **66**. For example, the sensor **84** can be positioned between the droplet generator **52** and the steering plate **74**. Further, multiple steering plates and multiple sensors can be provided in other designs.

The steering plate **74** is shown in FIG. **2** redirecting the stream **66** of droplets **68** about 90°. In other designs, the orientation of the droplet generator **52** relative to the primary optics **80** can provide a minimal amount of deflection of the stream **66** to provide the proper orientation. The present invention is intended to cover both minor and major direction changes of the stream **66** to correct for misalignment of the stream **66** for any reason. For example, the droplet generator **52** and associated hardware may be so cumbersome that it is difficult to get it properly oriented to the laser beam **78**. The steering plate **74** can be used to make minor adjustments to the stream **66** to provide fine tuning. Further, for whatever reason, the direction of the droplets **68** from the droplet generator **52** may change from time to time. The steering plate **74** can also be used to continually correct for the direction of the stream **66**, possibly on a drop by drop basis.

The steering plate **74** can be any solid surface or plate suitable to deflect a frozen material. The steering plate **74** can be small and lightweight, to allow for high frequency steering as well as DC pointing. Because the droplets **68** are frozen, they bounce quasi-elastically off of the steering plate **74**. Mounting the steering plate **74** to a tip/tilt actuator allows full steering flexibility and greatly reduces the alignment requirements with higher mass droplet generator systems. Additionally, high frequency translation of the steering plate **74** along the axis of the incident stream **66** can be used to introduce a variation in the total flight distance which counteracts for lasting variations in the droplet generator **52**.

The actuator **88** can be any high or low frequency actuator suitable for the various EUV source applications. High frequency steering response can be obtained using a galvanometer, voice coil, piezo-electrically driven actuators or MEMS type mirrors. The actuator **88** can be any suitable commercial off-the-shelf component, such as those used in conventional optical fast steering mirrors. Examples of such devices include, but are not limited to, actuators available from Ball Aerospace, GSI Lumonics, Piezosystems, and Applied MEMS.

The foregoing discussion discloses and describes merely exemplary embodiments of the present invention. One skilled in the art will readily recognize from such discussion and from the accompanying drawings and claims, that various changes, modifications and variations can be made therein without departing from the spirit and scope of the invention as defined in the following claims.

What is claimed is:

1. An extreme ultraviolet (EUV) radiation source, comprising:
 - a droplet generator, said droplet generator generating a stream of droplets along an initial path;
 - a steering device having a solid surface steering plate that deflects, said steering device deflecting the droplets from the initial path to a target path;
 - a sensor sensing the position of the stream of droplets;
 - an actuator responsive to a signal from the sensor, said actuator causing the orientation of the steering plate to change so that the droplets are deflected to a target location on the target path; and
 - a laser source generating a laser beam that is directed toward the target location.

5

2. The source according to claim 1 wherein the actuator is an actuator selected from the group consisting of galvanometers, voice coils, piezoelectric drivers, and MEMS devices.

3. The source according to claim 1 wherein the sensor is positioned relative to the initial path prior to the droplets being deflected by the steering device.

4. The source according to claim 1 wherein the sensor is positioned relative to the target path after the droplets have been deflected by the steering device.

5. The source according to claim 1 wherein the droplets are frozen when they are deflected by the steering device.

6. The source according to claim 5 wherein the droplets are xenon.

7. The source according to claim 1 wherein the initial path and the target path are about 90° relative to each other.

8. The source according to claim 1 further comprising primary optics, said target location being at the focal point of the primary optics.

9. An extreme ultraviolet (EUV) radiation source comprising:

a droplet generator, said droplet generator generating a stream of frozen droplets along an initial path;

a solid surface steering plate, said steering plate being positioned in the initial path and deflecting the droplets from the initial path to a target path;

a sensor positioned along the target path, said sensor sensing the position of the stream of droplets;

an actuator responsive to a signal from the sensor, said actuator causing the orientation of the steering plate to change so that the droplets are deflected from the steering plate to a target location on the target path; and

a laser source generating a laser beam that is directed toward the target location.

10. The source according to claim 9 wherein the actuator is an actuator selected from the group consisting of galvanometers, voice coils, piezo-electric drivers and MEMS devices.

6

11. The source according to claim 9 further comprising primary optics, said target location being at the focal point of the primary optics.

12. The source according to claim 9 wherein the initial path and the target path are about 90° relative to each other.

13. The source according to claim 9 wherein the droplet generator generates frozen xenon droplets.

14. A method of generating extreme ultraviolet (EUV) radiation comprising:

generating a stream of droplets directed along an initial path;

deflecting the droplets off of a steering device, having a solid surface steering plate, from the initial path to a target path;

sensing the position of the stream of droplets;

adjusting the direction the droplets are deflected from the steering device by causing the orientation of the steering plate to change based on the sensed position of the stream of droplets; and

generating a laser beam that is directed toward a target location.

15. The method according to claim 14 wherein sensing the position of the stream of droplets includes sensing the position of the stream of droplets prior to the droplets being deflected.

16. The method according to claim 14 wherein sensing the position of the stream of droplets includes sensing the position of the stream of droplets after the droplets have been deflected.

17. The method according to claim 14 wherein generating the stream of droplets includes generating a stream of frozen droplets.

18. The method according to claim 17 wherein the frozen droplets are xenon droplets.

* * * * *