



INTERNATIONAL  
HELLENIC  
UNIVERSITY

# ICT Infrastructure for the Smart Grid

**Michalis Zannetos**

SID: 3301100016

SCHOOL OF SCIENCE & TECHNOLOGY

A thesis submitted for the degree of

*Master of Science (MSc) in ICT Systems*

SEPTEMBER 2011

THESSALONIKI – GREECE



INTERNATIONAL  
HELLENIC  
UNIVERSITY

# **ICT Infrastructure for the Smart Grid**

**Michalis Zannetos**

SID: 3301100016

Supervisor:

Prof. Ioannis Vlachavas

SCHOOL OF SCIENCE & TECHNOLOGY

A thesis submitted for the degree of  
*Master of Science (MSc) in ICT Systems*

SEPTEMBER 2011

THESSALONIKI – GREECE

## DISCLAIMER

This dissertation is submitted in part candidacy for the degree of Master of Science in ICT Systems, from the School of Science and Technology of the International Hellenic University, Thessaloniki, Greece. The views expressed in the dissertation are those of the author entirely and no endorsement of these views is implied by the said University or its staff.

This work has not been submitted either in whole or in part, for any other degree at this or any other university.

Signed: .....

Name: .....

Date: .....

# Abstract

The objective of this work is to investigate the Smart grid concept and especially the ICT infrastructure of the Smart Grid. Smart metering is one of the most important characteristic of the smart grid since it enables real time monitoring of critical parameters. After all it is a fact that *'if you cannot measure it, you cannot improve it!'* Smart Metering provides only raw data. The benefit gained by the Smart Grid is that through data processing and applications of algorithms, the raw data are transformed into useful information which in return through long term observations and information exchange can turn into knowledge. Problem solving will go from detect and react to predict and prevent.

Advanced metering infrastructure (AMI) is comprised of a smart meter which reports the total home electricity power consumption to the utility company on a 15 minutes interval. That means 4 times per hour, 96 times per day or around 3000 times per month. If the consumer requires more precise control then an agent can be installed in each household which can manage almost all appliances individually. Different protocols and standards ensure that each device communicates to the house agent in order to report its consumption as well as receive control on/off commands. Today's trend is IP based protocols that operate either wirelessly or through the electric wiring. The Agent reports the overall electric power consumption to the area Supervisor which in turn reports the neighborhood electricity consumption to the utility company. Protocols like BPL, LTE, WiMax, xDSL are used for this purpose.

When the utility company faces congestion load, it can sent orders to neighborhood individually (through the Supervisors) to reduce their electric consumption. The Supervisors then order the agents to reduce the house consumption through actuating devices individually.

I would like to thank Professor Ioannis Vlachavas for the giving me the opportunity to develop my analytical skills and to gain knowledge on the subject. I would also like to thank the Smart IHU team which is comprised from researchers Dr. Aggeliki Tsioliaridou, Mr. Athanasios Stavropoulos and Dr. George Koutitas for all their support throughout the whole dissertation. Finally I would like to thank my parents for being supportive trough my first thesis writing.

Michalis Zannetos

Date



# Contents

<b>ABSTRACT .....</b>	<b>IV</b>
<b>CONTENTS.....</b>	<b>VII</b>
<b>1 INTRODUCTION .....</b>	<b>1</b>
<b>2 LITERATURE REVIEW .....</b>	<b>5</b>
2.1 WHAT IS THE SMART GRID? .....	5
2.2 BASIC SMART-GRID ARCHITECTURE .....	6
2.3 MAIN COMPONENTS AND DEFINITIONS.....	7
2.3.1 <i>The Agent</i> .....	7
2.3.2 <i>The Supervisor</i> .....	8
2.3.3 <i>Smart Electricity Meter</i> .....	9
2.3.4 <i>Electricity Provider</i> .....	11
2.4 MAIN SERVICES OF THE SMART-GRID .....	11
2.4.1 <i>Monitoring and control</i> .....	12
2.4.2 <i>Energy Management</i> .....	13
2.4.3 <i>Load Management</i> .....	15
2.4.4 <i>Failure detection</i> .....	17
2.4.5 <i>Back up mode</i> .....	18
2.5 ELECTRICITY TARIFFS OPTIONS .....	20
2.5.1 <i>TEMPO Tariff</i> .....	20
2.5.2 <i>EJP Tariff</i> .....	20
2.5.3 <i>BASE Tariff</i> .....	21
2.5.4 <i>ARCHITECTURE FOR PRICE SIGNAL MANAGEMENT</i> .....	21
2.6 ICT FOR THE AGENT .....	22
2.6.1 <i>Requirements for the Agent</i> .....	22
2.6.2 <i>Agent Specifications</i> .....	24
2.6.3 <i>Agent-Appliances interfaces</i> .....	25

2.7	ICT FOR THE SUPERVISOR .....	30
2.7.1	<i>Requirements for the Supervisor</i> .....	30
2.7.2	<i>Supervisor Specifications</i> .....	31
2.7.3	<i>Electricity Company - Supervisor interface</i> .....	32
2.7.4	<i>Web services</i> .....	32
2.8	KEY INITIATIVES .....	34
2.8.1	<i>Home Gateway Initiative (HGI)</i> .....	34
2.8.2	<i>ZigBee Alliance</i> .....	35
2.8.3	<i>Internet Protocol for Smart Objects (IPSO)</i> ..... <i>Σφάλμα! Δεν έχει οριστεί σελιδοδείκτης.</i>	
2.8.4	<i>HomePlug Alliance</i> .....	37
2.9	NETWORKS AND PROTOCOLS.....	37
2.9.1	<i>X10</i> .....	42
2.9.2	<i>LonWorks</i> .....	43
2.9.3	<i>HomePlug</i> .....	45
2.9.4	<i>Wi-Fi</i> .....	48
2.9.5	<i>Zigbee</i> .....	51
2.9.6	<i>6LoWPAN</i> .....	53
2.9.7	<i>DSL</i> .....	54
2.9.8	<i>BPL</i> .....	55
2.9.9	<i>GPRS-3G-UMTS-HSPA-LTE</i> .....	56
2.9.10	<i>WiMax</i> .....	57
<b>3</b>	<b>PROBLEM DEFINITION .....</b>	<b>58</b>
3.1	NETWORK LOAD SHEDDING (I.E. ROLLING BLACKOUT) .....	58
3.2	CONTRACTUAL LOAD SHEDDING .....	58
3.2.1	<i>Time-of -Use</i> .....	58
3.2.2	<i>Dynamic Pricing</i> .....	59
3.2.3	<i>Direct Load Control</i> .....	59
3.2.4	<i>Paid-for-Performance mechanism</i> .....	60
3.3	LOAD MANAGEMENT ACTIONS THAT CAN BE TAKEN AT THE MICRO LEVEL (END USER).....	61
3.3.1	<i>Individual load shaving</i> .....	61



3.4	LOAD MANAGEMENT ACTIONS THAT CAN BE TAKEN AT MACRO LEVEL (UTILITY OR SERVICE PROVIDER)	64
3.4.1	<i>Individual Load Shifting to avoid peak loads</i>	64
<b>4</b>	<b>CONTRIBUTION</b>	<b>66</b>
4.1	MEASUREMENTS	66
4.1.1	<i>Academic Assistants' Office Fan Coil</i>	66
4.1.2	<i>Corridor Fan-Coil</i>	67
4.1.3	<i>Course office fan-coil</i>	69
4.1.4	<i>Water-Chiller</i>	70
4.1.5	<i>Fridge</i>	71
<b>5</b>	<b>CONCLUSIONS</b>	<b>72</b>
<b>6</b>	<b>REFERENCES</b>	<b>75</b>



# 1 Introduction

It is a truth universally acknowledged that the world needs more energy. Yet despite this truth, the modern world finds itself in a situation where traditional resources are becoming increasingly limited. With this in mind, it is crucial that energy becomes more transparent, meaning more affordable, sustainable and in this way more reliant. Better distribution of energy would create less generation and more efficient consumption; this is why we need a new approach to energy, a smart approach. Intelligent buildings are waiting to talk to a grid just as smart as they are. Thus through intelligent communicating grids, we can eliminate power interruptions and therefore become much more efficient in our energy consumption. Since man discovered electricity, the demand for electrical energy has reached new heights and has caused electrical power to become THE most important energy carrier. Up to now power transmission was unidirectional. In other words large power stations would generate power, and industrial facilities and domestic households would consume it. However, this approach has fundamentally changed because many consumers have now taken the role of the producer, causing power flow to become increasingly bidirectional. Therefore, today's power grids have become more and more complex with no distinct differentiation between the classic roles of the producer and the consumer. To be able to control efficiency, network stability must be maintained at all times, as precise control of load and demand keeps the grid stable. Smart grids are 'smart' as they ensure a reliable supply of electricity for our future. Ecologically sound, safe and efficient, a smart grid can optimally balance such fluctuations and effortlessly integrate all generators into the grid creating a smarter more efficient tomorrow.

In addition, electricity distribution grids are also evolving into a technical state which is increasingly personalized and thus safe and where their chief aim is to

eliminate the chaos of peak demand. High peak demand is problematic as it often necessitates the use of additional 2<sup>nd</sup> tier plants to support the grid that are disputably less efficient and less green. In this sense load leveling would also reduce the carbon footprint, an advantage that goes beyond its obvious effect on grid stability. Peak demand shaving, flexibility, efficiency and new ways of interaction between producers and consumers should therefore all be considered in smart-grid.

In today's world it is clear that the building sector consumes the most energy. EU statistics show that the building sector accounts for some 40% of overall European energy consumption whilst Industry and Transport follow close behind at 30%. It seems that residential buildings are the forerunners of European energy consumption accounting for 20% of European energy consumption, rural buildings following at 17% and industrial buildings at 3%

### European Energy Consumption

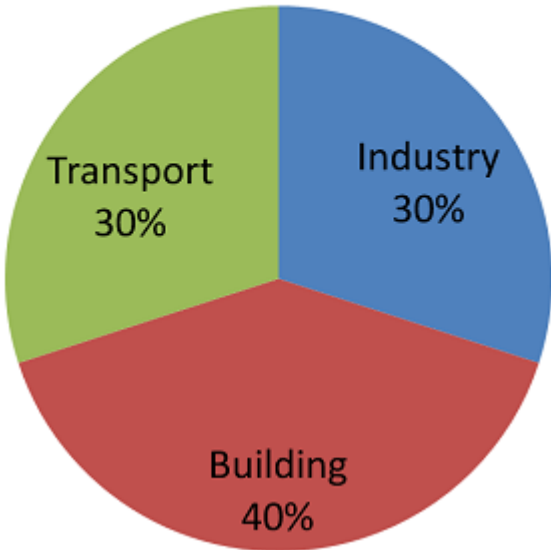

Figure 1 - Repartition of Europe Energy consumption

In today's world it is clear that the building sector consumes the most energy. EU statistics show that the building sector accounts for some 40% of overall European energy consumption whilst Industry and Transport follow close behind at 30%. It

seems that residential buildings are the forerunners of European energy consumption accounting for 20% of European energy consumption, rural buildings following at 17% and industrial buildings at 3%. The energy consumption of the building sector has increased dramatically by 30% over the past three decades and increased by 1.4 % annually over the previous decade. New technology has caused energy consumption to rocket in the building sector, as every modern building now demands facilities such as air conditioning and modern consumer electronics, which challenge both states and individual companies in their pursuit to limit energy consumption. In this context, new regulations related to building energy efficiency constitute the first step towards energy consumption management and are increasingly plaguing the energy policies of each member state.

In terms of CO<sub>2</sub> emissions, the European building sector is ranked second, just after transport accounting for some 25% of all CO<sub>2</sub> emissions. Despite the severity of these figures, the European Green Book [1] has stated that energy consumption can be decreased by up to 20% by 2020, if Europe becomes more energy smart and efficient. A more energy efficient Europe is advantageous in many ways which include the creation of new jobs in the energy efficiency sector, the reinforcement of industry competitiveness and a significant contribution to Europe's commitment in regards to the Kyoto protocol [2]. The European Green Book predominately addresses three different areas: Transport, Energy production and Buildings, and gives several proposals to cut energy consumption in each area. In the transport sector, the European Green Book suggests that the promotion of clean, energy efficient and low cost vehicles can save energy. Moreover, in the area of Energy Production, in which, over 60% of losses can be connected to inefficient production, the use of more efficient conversion techniques and the promotion of distributed production and co-generation systems is suggested. Similarly, in the Building sector the European Green Book calls for the achievement of important savings by specific measures.

However, The Action Plan for Energy Efficiency (2007-12) [3] has revised and thus substituted the above measures proposed by The European Green Book (2000-2006),

by establishing more concrete actions to fulfill the objectives of the its predecessor the Green Book. The new Action Plan states that from now until 2020 it is still technically and economically possible to save an estimated 20% of the total primary energy consumed within the European Union, without the implementation of tougher price policies, structural changes in the economy, which would of course further decrease energy consumption. Like the Green Book, the Action Plan focuses on energy savings in three specific areas, which constitute the residential and commercial building sector where energy can be cut by some 27-30% respectively, the manufacturing industry sector where energy can be cut by 25% and finally the transport sector in which a similar percentage of energy can be saved (26%).

The Action Plan and the Green Book both call for: improvements in energy production processes, the specification of energy performances for energy reliant products and buildings and energy services, the promotion of advances in transport and most importantly a cultural change regarding energy behavior.

It is clear that energy consumption and costs will increase over the next few years. The main challenge utilities are facing is to reliably provide the amount of energy required by our increasingly energy-hungry digital lifestyle. Utilities cannot simply build more power plants that would be used only during peak demand because of prohibitive costs and environmental concerns regarding carbon emissions. Even if they could, the environmental and social cost of building new transmission lines is just as significant.

## 2 Literature Review

### 2.1 What is the smart grid?

The term 'smart grid' is a term used to name a system that delivers electrical energy merging both digital technologies and long transmission networks to optimize energy consumption. In addition, this system creates new processes that can be used for production and distribution.

The main driving factors to enhance current power distribution grids can be classified into different categories. The first category sees the 'smart grid' improve the reliability of the distribution grid by decreasing blackout or brownout risks through measures that decrease peak demand. Moreover, this category also improves the efficiency and safety of the distribution grid. The second category focuses on the enhancement of the flexibility of power consumption. Finally, the third category allows homes to act as either electrical energy clients, in other words consumers, or as electrical energy suppliers, in which the home assumes the role of the energy producer.

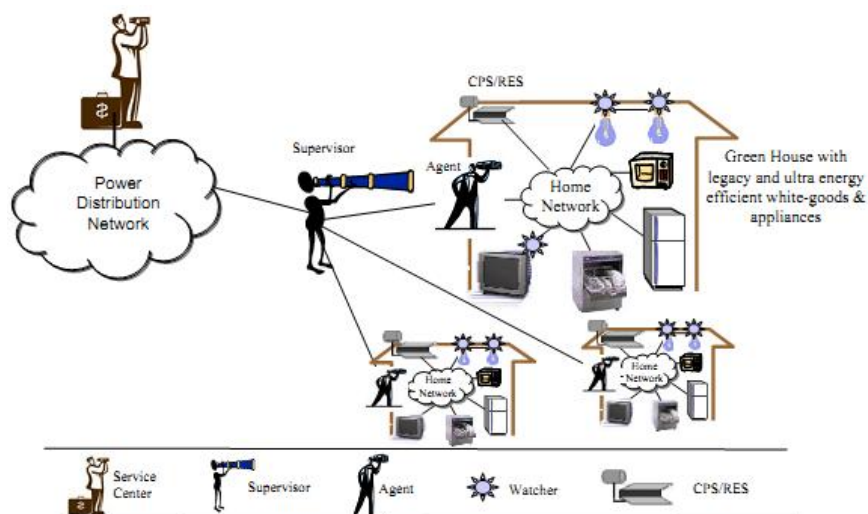

Figure 2 - Smart-Grid Hierarchical Deployment Architecture

## 2.2 Basic Smart-grid architecture

The smart-grid concept includes hierarchical network architecture of interactive metering and intelligent control devices:

- in-home metering and control intelligent devices ;
- Agents at Home level ;
- Supervisors at building, square or neighbor level ;
- Service Centre.

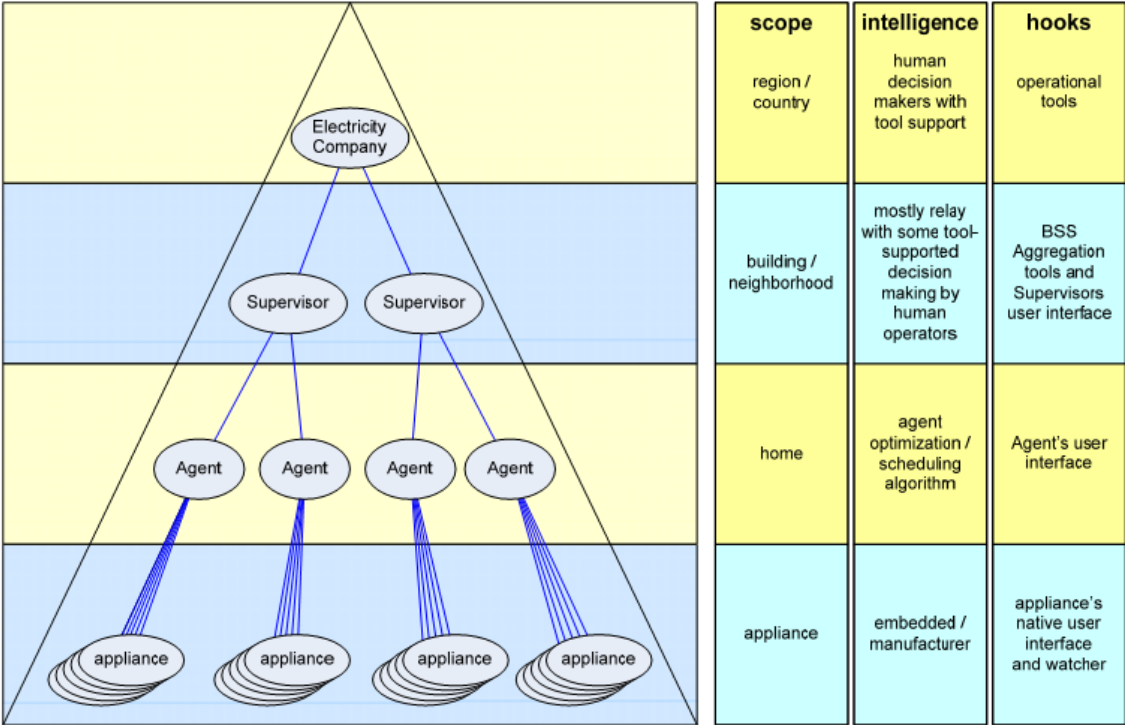

Figure 3 - Elaborated hierarchical control structure at smart grid and scope, intelligence and available hooks on each layer.



## 2.3 Main components and definitions

### 2.3.1 The Agent

The purpose of the agent module is to lead to transparent energy consumption, based on user preferences. The system will not only be able to define preferences and energy consumption scenarios based on the time, in-home activities and environmental conditions (e.g. indoor and outdoor temperature, rain/wind etc.), but also to generate sequences and schedules for home appliances and white goods operation occurring during peak-time periods. To enable seamless access to the watchers, white goods, sensors, actuators and appliances, the smart-grid services will be designated as resource agents between the network architecture and the user application. To support such functionality they will be able to discover the capabilities of the household appliances in the proximity, instantiate and bind their resources to the user application.

The Agent can be considered as the close combination of a residential gateway (RG) and a smart electricity meter. This is essentially a functional view, provided that these two basic components can be operated by different actors (of different nature, such as an electricity distributor, an electricity retailer, a telecom operator, a service provider, etc.). Moreover, only the residential gateway will be able to embed the communication capabilities and the software intelligence requested by the smart-grid solution.

This residential gateway will be an HGi based, sophisticated, yet low-cost monitoring/remote-control platform, integrating both a remote-managed appliances/white-goods controller and a communication module. The platform will seamlessly communicate with the various white-goods, energy-consuming or energy-producing devices in order to calculate constantly in real-time the instantaneous energy consumption and production of the home. The Residential Gateway will also be able to communicate with the smart electricity meter as well as with the higher layer

of the smart building/square/neighborhood monitoring and controlling device (i.e. the supervisor).



Figure 4 - Small factor pc that can be used to run an agent

### 2.3.2 The Supervisor

In addition to a local control device at the house level (the Agent), a more global control tool named the Supervisor will be included and will cover a larger geographical area (at neighborhood or block level). The Supervisor will be used as a statistical data provider and also as an energy resources coordinator. This will be an open and distributed system/platform for the supervision of energy consumption and power demand. It will aggregate the lower hierarchy layer “Agent” consumption patterns, and be able to remotely supervise the smart homes consumption based on the network conditions, the electricity requirements forecast and the customers energy contract. Based on the business model and the network architecture, a utility company will be able to utilize the Supervisor as a service aggregator at the neighborhood level.



Figure 5 - Server that acts as a Supervisor

### 2.3.3 Smart Electricity Meter

The smart electricity meter performs as a communicating device able to provide information to users regarding energy consumption, subscribed power, subscribed intensity, etc. It is also able to relay data coming from the utility (electricity distributor) directly to the user such as current tariff period, tomorrow's tariff and so on. The smart electricity meter is equipped with a modulated serial communication output that periodically and permanently broadcasts information contained in the meter internal memory. One of the smart electricity meter model does look as follows:



Figure 6 - Smart Electricity meter

The smart electricity meter transmits periodically (typical time interval: around 1s) a certain amount of data as time-series frames that can be processed by a connected device (ex. the Agent). The connected devices may take different forms: a remote display unit, a load management device able to read what is coming from the smart meter, etc. Since the intelligent metering device is able to send data, the connected devices will be capable of providing information that could be relevant to achieve load management as well as energy consumption reduction through incentive information (current tariff periods for instance).

### **Electricity Watchers / Actuators**

Electricity “Watchers” must fulfill the functionality of sending in near real-time the consumption of the “dumb” in-home appliances (i.e. appliances which are not natively smart-grid compliant). Electricity Watchers must be easily placed between the wall socket and the plug of the appliances. It could also be advantageous for energy savings reasons to have a smart socket that would incorporate an intelligent on/off switching mode controlled wirelessly by the Agent either manually or automatically through pre-set switching schedules.

Therefore, they must be compatible with European domestic networks and potentially with fully meshed low consumption communication networks (based on IEEE 802.15.4 standards such as ZigBee, 6LoWPAN, and so on). The communication standard implemented for these plugs must be an open international standard and easily extendable with additional plugs from different brands. It could be of great benefit to have a Watcher compatible with UPnP middleware in order to make configuration process as simple as possible. They must integrate a physical address (different MAC address per electricity watcher) in order to be identifiable by the Agent.



Figure 7 - Electricity Watcher

From a communication point of view, some of these Watchers must also perform as routers, building a mesh network by “hopping” from one Watcher to another, until the Agent is reached.

### **2.3.4 Electricity Provider**

This is the level at which human operators have an overview of an entire national or regional grid and are supported by analytical or forecasting tools to reach decisions, develop new products (contract options for consumers) and send instructions to Supervisors. It is also the level at which provisioning is conducted. Software updates and maintenance of the Agent software infrastructure takes place at this level (while it is also possible that certain provisioning functions will be implemented at the Supervisor level).

## **2.4 Main services of the smart-grid**

The purpose of the smart-grid system is to provide services to both the end-users and the electricity providers. The services that would be provided can be classified into the following categories:

- monitoring and control services, that are mainly provided to the end-users,
- energy management services, that are mainly provided to the end-users,
- load management services, that are mainly provided to the utility,

- failure detection services, that are mainly provided to the end-users,
- back up mode, that would mainly be used by end-users.

### **2.4.1 Monitoring and control**

One of the smart-grid project main objectives is to design a monitoring and control system targeting energy efficiency and environmental sustainability at the home level. As a consequence, the system will be able to perform interactive energy monitoring and intelligent energy consumption control based on power demand, network conditions and end user personal preferences. The system is implemented on a hierarchical platform able to monitor the energy consumption at the device, home and neighborhood levels as well as the energy produced from renewable energy sources (ST and PV panels). Moreover, the system will be able to intelligently control the energy consumption by scheduling appliance operation so as to limit as much as possible the home power demand during peak loads.

The main issue an energy efficiency solution based on minimizing appliances energy consumption and balancing energy production and distribution at both micro and macro levels (i.e. respectively houses and neighborhoods). Such solutions should help to save energy and to decrease service costs for the power distribution network.

#### **Monitoring and Control actions that can be taken at the Micro level (End user)**

All home white goods, appliances and electrical devices will be set under local and interactive monitoring rules. The smart home will be able to capture the end users behavior and habits generating end users profiles, identifying an increase or a decrease in energy use or even deriving energy consumption trends from the collected data. By providing such analysis of the consumption pattern of the home to the GUI, end users would be able to monitor and to analyze their own consumption and, if they wish to do so, to change their habits so that their energy consumption profile reflects their real preferences (energy savings, carbon neutral lifestyle, ...).

In addition to the monitoring system, specific devices will be added to the overall system in order to smartly control energy consumption. Intelligent control will entail all the actions targeting at reducing the overall energy consumption of a house by communicating with as well as remotely managing the appliances. By controlling and scheduling the appliances operation, smart-grid aims at minimizing power consumption peaks. The Agent will be responsible for controlling energy consumption at the home level and will also transmit information about the actual home energy consumption to the higher layer of the system.

### **Monitoring and Control actions that can be taken at the Macro Level (Utility or Service Provider)**

Intelligent control at the macro level (i.e. utility or service provider level) will involve all the actions made to monitor the energy consumption at the neighborhood level. Information related to houses instantaneous and/or overall energy consumption will be transmitted and centralized, which will enable utilities to analyze and therefore predict the energy consumption of large areas.

## **2.4.2 Energy Management**

Energy efficiency is a major concern for sustainable development activities because increasing energy consumption implies an increase in CO<sub>2</sub> emissions and through such emissions long lasting effects on global warming. The energy demand has been constantly growing over the last years, partly because of the emergence of new electrical applications such as new services and new technologies for transportation, requiring increasing investments in the energy producing sector.

Furthermore, during some specific periods, the electricity distribution network can be under stress because of high power demand. In order to face the rising electricity demand, a number of solutions for efficient energy consumption can be found. Indeed, energy management entails all the actions that could influence the demand for energy such as actions to suppress ineffective energy consumption and actions to dimmer

energy consumption at large or medium scale. Energy generation from renewable sources, and new power distribution business models for active energy control have been promoted and sometimes have been even legitimized via regulations at the national and European level. Besides, it is often mentioned that energy efficiency and renewable energy are the so-called “twin pillars” of sustainable development [4]. These are fundamental if energy demands are ever to be decreased. This is the reason why the smart grid system is designed to increase both energy efficiency and the use of renewable energies at the home and neighborhood level in order to decrease the home overall energy consumption.

### **Decreasing end users energy consumption will foster savings in electricity distribution network investments**

Decreasing end user energy consumption at a large scale will obviously reduce the overall energy consumption and thus the high-energy demands. Nowadays, the network distribution and generation capacity is sized to support most of the usual energy demand. Knowing that energy demand is increasing year after year, the needs for investments in network production and distribution capacity will be growing.

Therefore, decreasing end users energy consumption will reduce the need for investments in distribution networks and avoid additional investments for supplementary power plants. The reduction of energy consumption will also reduce the risk for potential disturbances and reinforce the network reliability. These energy savings will not only have a beneficial impact on the environment but also on energy prices. Indeed, for real-time pricing energy contracts, energy prices partly depend on the equipment required to fulfill the energy demand. This is the reason why energy savings will affect both the customers and the suppliers. Suppliers will lower their needs in power installation while customers will pay lower prices for their energy.



## **Decreasing end users energy consumption will foster savings in power lines energy losses**

Transmission losses represent the amount of energy lost in an electrical distribution system because of either or both the electrical resistance of the conductor lines or the conversion between high voltage input and safe low voltage output for homes. Most of this energy is transformed into heat and wasted. Transmission losses are typically range from 5% to 7% of the total power put into the grid in European countries. For instance, in Europe, the resistive losses in conductor lines alone amount to the equivalent of 20 million tons of coal, 3.1 million tons of gas and 1.7 million tons of oil. These annual losses cost around €12 billion and are at the origin of CO<sub>2</sub> emissions that reach up to 60 million tons [5].

One possibility for reducing transmission losses is to lower the transmitted amount of power. Indeed, power losses exclusively depend on the so-called Joule effect and are directly linked to the amount of transmitted power. As a consequence, the solution could rely on decreasing the amount of transmitted power by lowering individual households' consumption which will in turn reduce the transmission losses. Hence, CO<sub>2</sub> emissions due to power losses will also be reduced.

### **2.4.3 Load Management**

Load Management implies the actions that influence and reduce the power demand at peak load times when stress over the grid is sensed. Load Management can also schedule and shift power demand from on-peak load periods to off-peak load periods. Peaks arise often in winter in cold countries because of heating needs and in summer in hot countries because of Air-Conditioning needs. Load Management does not necessarily decrease the overall energy consumption but nevertheless reduces the need for investments in power plants and electrical networks.

Because Load Management aims at keeping the instantaneous power consumption below a given threshold for balancing the grid, it reinforces the network reliability and the energy supply efficiency as well as decreases the risks of brownouts, power

outages or even blackouts. Load Management has been for a long time reached by shedding part of a geographical zone and thus disconnecting users from the electrical network. But nowadays, things have changed and power demand is regulated locally rather than globally. Back in time, loads were passive and dependent on decisions at large scales whereas these days investigators are looking to balance the grid at a smaller scale involving entities taking part in the electrical network efficiency and reliability. For instance, Demand Response can be described as an incentive mechanism used to lower consumer's power demand during peak load periods. This requires relevant measures and communication equipment as well as monitoring devices. Manageable loads such as smart appliances could for instance be used to provide services to utilities for power balancing.

### **Driving factors**

Load Management can answer to both economic issues associated with profit and cost reduction and to technical issues related to power distribution, grid operation and electrical systems security. Electrical systems security consists partly in stabilizing the frequency level and the voltage level of the grid. Voltage level stabilization can be achieved by avoiding brownouts through load management. Furthermore, electrical power storage able to deliver its energy rapidly could be a solution to an immediate lack of available power. Electrical systems security can also be achieved by a grid able to mitigate power outages and service disruption by itself (i.e. self-healing). Besides, the electricity supply quality has to be maintained as well as the production/consumption balance with an electric grid integrating a high level of renewable energy sources.

Last but not least, optimization costs motivate Load Management through the reduction of peak loads that will affect the electricity production costs and maximize the profit for both users and energy suppliers.

Load management is further analyzed on chapter 3.

#### **2.4.4 Failure detection**

Failure detection can be viewed as a fundamental mechanism allowing the user to know when something is not working as it is supposed to do.

Failure detection mechanisms can be applied to two different types of failure:

##### **Appliance Failure detection**

The objective of appliance failure detection is to detect failures of the appliances connected to the system and to decide what to do afterwards. For instance, this consideration is a key point for gas or high-voltage devices because breakdowns can have a serious impact on human health and safety.

After detecting a failure, some action can be taken by the system, depending on the failure severity. An in-home appliance failure can be detected by different means these being either by the appliance itself, the Agent, which is fed information by the appliance, or sensors that can detect problems such as instantaneous or great increase in temperature. Moreover, detecting a failure does not necessarily mean that the failing appliance has been identified. This is the reason why there is a need to add rules to detect which appliance caused a power failure that impacted the overall system

On the other hand, it would not be interesting to detect a failure without answering to the failure. Therefore, a recovering process must be established and its speed and intensity must be adapted according to the importance of the failure. One way would be to ignore the failure entirely in case of a minor problem such as a light bulk breakdown or merely attempt to diagnose and then to auto-fix the failure by remote maintenance. Furthermore, the device could be switched off, the end-users could be informed by a message on the system interface or a remote-technical platform could be contacted via a higher layer of communication system.

## **Communication failure detection**

An efficient communication failure detection method is crucial for reliable exchange of miscellaneous information and recovery from failure. Most networks hold autonomous failure detection process through heartbeat processes, which consist in polling nodes in the network and then waiting for a reply. If no reply is received within a particular time it means that a communication link is likely to have been damaged.

The communication failure can be caused by server failure, device communication interface failure, communication link/channel failure or network congestion.

Moreover, the failure detection can be achieved fairly rapidly according to the polling frequency which will allow to adapt a response process and thus not to affect tasks dependent on these messages for a long time. For this reason, some recovery process can be established to provide more reliable exchange of information. For instance, if the network allows performing a hop-by-hop routing process, a message can be rerouted along others paths as soon as a failing communication link/node has been localized. This will result in more reliable communication services and more effective communications given that the network is able to recover by itself from communication failures. Last, the system may still be able to perform its main features and to work as it is expected to do.

### **2.4.5 Back up mode**

A back up mode will allow end users to keep the same level of comfort in case of a system failure. The system failure can arise from a component failure or a communication network problem. This is why a transparent backup mode must be integrated into the system in order to handle failures and to offer solutions as an alternative to the system breakdown either at a micro (i.e. End user) or macro level (i.e. Utility or Service Provider). In case of a failure, the system must allow end users to do whatever they intended to do (wash dishes, watch TV, have a shower, get clothes washed....), otherwise the system may face rejection.

### **Back up mode at the Micro level (End user)**

The Agent back up mode will be actuated when the Agent (or one of its components) will stop functioning. Although smart-grid services will not be provided, end users must still be able to do what they need to do (e.g. to get clothes washed, have a shower ...). This is the reason why it has been assumed that in case of an Agent failure the home will be operated as a non-smart home. All the end users actions will be still possible but the Agent functionalities will not be carried out. The energy, load and tariff optimization will not be possible and none of the appliances or electrical devices in the home will be controllable from the GUI. The end users will have to set up what they desire to do directly on the appliance. The house will thus become again a regular house with appliances working as they do in our houses.

### **Back up Mode at Macro and National Level (Utility or Service Provider)**

At a larger scale, a failure may generate other outcomes such as the impossibility for the system to offer some of its basic functionalities. As a smart-grid system failure arises, the functions of monitoring and controlling energy consumption will not be carried out. The utility and the service provider will still send information (tariffs, orders, peak load period ...) but they will not be interpreted by the system. Therefore some fundamental functionality such as remote load shedding orders or incentive information (e.g. tariff) will not be achieved and thus will prevent the system from performing its optimization tasks.

## **2.5 Electricity tariffs options**

### **2.5.1 TEMPO Tariff**

The idea of the tempo tariff option was to offer a new tariff structure with a price depending on 6 time-periods rather than two (peak time-period and off-peak time-period). Indeed, each day is divided into two fixed time periods: Peak hours (often occurring during the day) related to the highest energy price of the day and Off-peak hours (often occurring during the night) related to the lowest energy price of the day.

In addition to the differentiation made according to the time period, the year is now also divided in 3 different periods related to different energy levels. These periods are 300 blue days (the energy is the least expensive), 43 white days (medium price for energy) and 22 red days (the most expensive price for energy).

As a consequence the most expensive periods are for peak-periods occurring during red days whereas the least expensive periods are for off-peak periods occurring during blue days resulting in 6 different time periods and thus offering 6 different tariffs. The type of the day is dynamically determined by the national electricity grid at the end of each day for the next day, and transmitted by the Utility (electricity Distributor) to all the EDF intelligent metering devices. This tariff is an incentive to lower energy bills and also to manage extreme peak demand period.

### **2.5.2 EJP Tariff**

The “EJP” tariff option has been designed to discourage users to consume energy when disruption is sensed on the grid. It often happens in winter in North Countries (because of heating systems that consume a large amount of energy) whereas it occurs in summer in South Countries (because of cooling system that also consumes a large amount of energy). The principle is to impose to “EJP” customers 22 days of

overcharged tariffs of 18 hours duration (from 6 p.m. to 1 a.m.) from the 1st of November to the 31st of March. However, “EJP” customers can benefit from lower priced energy tariffs during the rest of the year.

### 2.5.3 BASE Tariff

The “Base” tariff is a single-rate based tariff option. When speaking of the single-rate tariff option, we suggest that no distinction is made between peak and off-peak periods because the energy price will stay constant over the time.

The tariff structure can be defined by two parameters these being either the voltage level (3kW, 6kW, 9kW, 12kW, 15kW, 18kW, 24kW, 30kW, 36kW) or the kWh price. The monthly invoice can be computed from demand power level and a fixed energy price all year long.

### 2.5.4 ARCHITECTURE FOR PRICE SIGNAL MANAGEMENT

Nowadays, the Tempo tariff option is the more flexible tariff option offering the larger number of price periods and thus allowing the best price-based optimization. The “historical” architecture of such a system is as depicted below:

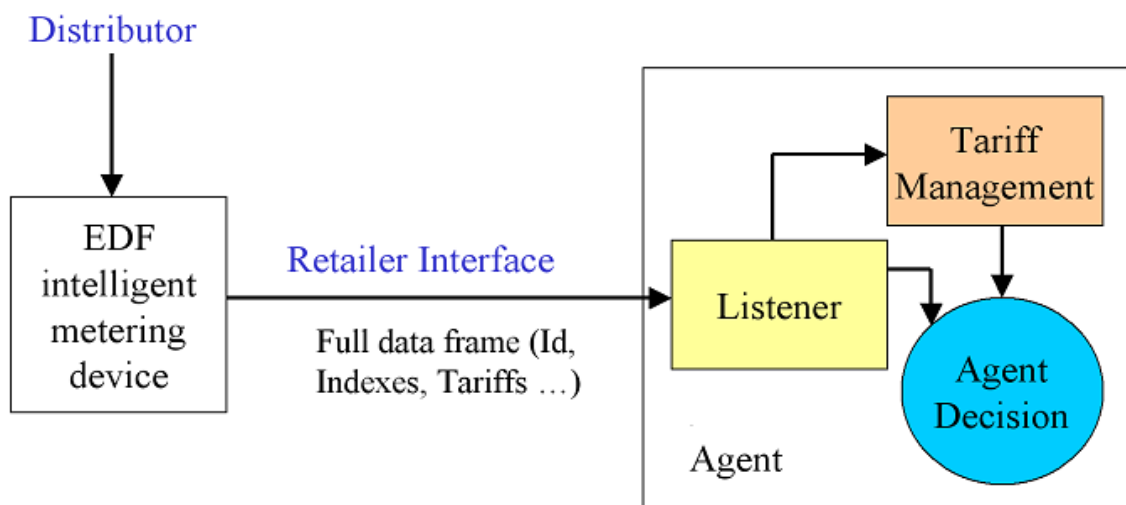

Figure 8 - Tempo Tariff Option

Typically, the price signal is emitted by the electricity distributor – through its communication infrastructure - to the EDF intelligent metering device, which is considered as a full trusted device due to its certifications and deployment processes. Then, the EDF intelligent metering device transmits it to the Agent through the Retailer interface (“tele-information” interface) in a full data frame containing meter Id, indexes, tariff and more over. As depicted, the Agent is now aware of the current tariff period and the decision can be completed, by taking into account both external parameters (information related to appliances, PV, etc.) and the price signal features.

## 2.6 ICT for the Agent

### 2.6.1 Requirements for the Agent

The agent is one of the key factors for the success of the project since it is the piece of software that monitors and controls locally a variety of devices such as metering devices, watchers, white goods etc. and is responsible for the overall optimization of energy consumption and power saving functions. Therefore, it is important for the agent to include the following features:

- **Being able to be deployed on low cost residential gateways:** The agent should not use specialized hardware to communicate with the different devices in the home; ideally the Agent should use COTS hardware interfaces. In the practice, it could happen than external adaptors are needed, but in that case these adaptors will be connected to the COTS hardware interfaces of the residential gateway.
- **Zero-touch installation procedure:** The software part of the agent shall be installed in the residential gateway of the user in a transparent manner. The agent software will be automatically deployed, installed and started when the user subscribes smart grid services. Any required hardware interfaces shall also



be installed by simply plugging them in the right ports. The appropriate drivers will be remotely downloaded and installed in the residential gateway in that case.

- **Automatic devices discovery:** The Agent shall be able to automatically detect devices (wherever possible) such as watchers or white goods. This will minimize the need for configuration and make the agent more usable.
- **Flexibility:** The Agent will support multiple policy profiles. Each profile will reflect the energy preferences of the user relative to incentives / counter-incentives provided by the utility company and the amount of control the user is willing to relinquish to the utility company / grid administrator so as to save money or protect the environment. The Agent will come with a default policy profile already pre-installed so that it will be operational out-of-the-box even if the user does not explicitly select a profile.
- **Ease-of-use:** Changing policy profiles should be easy. Equally important, but more challenging to implement, is that the graphical user interface should present to the user in a common, graphical, easy-to-grasp format what exactly are the characteristics that identify each profile and set it apart from the others. Such characteristics for example include what difference each profile can make with respect to cost, the environmental impact of each profile (e.g. carbon footprint differences), and the amount of control each profile will assume over the scheduling of house activities. All the above information should be presented in a concise way that's readily understandable even by non-sophisticated users.
- **Automatic upgrades:** New versions of the agent will be deployed, without human intervention, as soon as they are available.

## 2.6.2 Agent Specifications

Functional requirements of the Agent:

1. controller for remotely-managed appliances / white goods
2. supports UPnP and vendor-independent ubiquitous networking
3. supports, stores and maintains user preferences and have concept of user profiles
4. provides home-level data to the Supervisor (for aggregation) and acts according to commands received by it. In other words, be able to translate higher-level energy-related commands (e.g. “try to reduce power consumption for the next three hours by 30 %”) to an appropriate mix of appliance-specific commands while also taking into account user preferences.
5. collects and communicates to the Supervisor intelligent metering device readings (in/out)
6. qualifies as a service gateway for the support and delivery of energy management, energy-saving and power consumption balancing services.
7. responsible for green and energy consumption aware devices’ discovery within the house
8. receives status report changes from the smart devices (whether their status has been changed manually or through a remote control operation)
9. be able to proactively query (as opposed to passively receive status change messages that is also supported in the point above) smart devices as to their: (a) status, (b) instant power consumption, (c) cumulative energy consumption.
10. be able to proactively zero the counters kept by the smart devices (ibid). The Agent might decide, based on its own reasoning to zero counters kept by smart devices to avoid overflow. This implies a capability of the devices to know and to communicate to the Agent their counter capacity or, alternatively, to inform the Agent whenever a counter has overflowed (and thus zeroed) so that the Agent will not be confused with inconsequential readings.
11. communicates with the Service Centre of the provider ( via the Supervisor). This communication will be two ways: (a) reporting consumption and device status or

important events and also (b) receiving instructions from the Supervisor for energy consumption targets. In the first sense the reporting can be done either as input to the decision making processes of the Supervisor or the Service Centre operations personnel or to allow the home-user to monitor the status of his home through a web-interface (supported by the Service Centre internet connectivity).

### **2.6.3 Agent-Appliances interfaces**

The Agent-Appliances interface is used to remotely manage the appliances so as to promote house-wide energy-related consumption management. This interface can also receive feedback from the appliance regarding (primarily) its current status or, (secondarily) aggregate information about past events (e.g. average daily consumption for the last month whenever such information is available). Finally, the agent appliance interface can implement a service-discovery mechanism enabling PnP functionality. The Agent should be able to discover available appliances (or vice-versa) without requiring any kind of configuration. Similarly, changes in the available appliances (removal or shutting-off of an appliance) should be discovered automatically.

Feedback from the appliance might be implemented either by periodic polling of the appliance by the Agent or by the appliance proactively initiating communication with the Agent

#### **Agent - Electricity Meter Interface**

The smart electricity meter functional interface with the Agent is described in figure below:

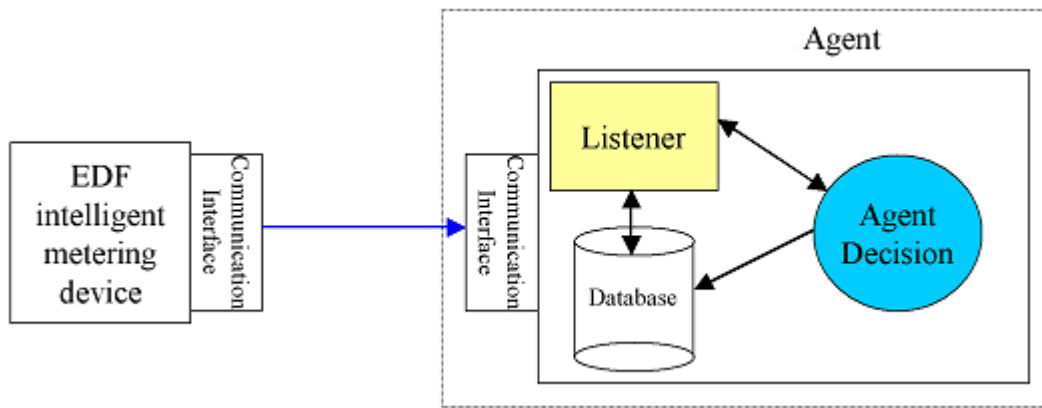

Figure 9 - Interface Between the EDF Intelligent Electricity Meter and the Agent

The Electricity Meter relevant “state items” are the following:

- Electricity Meter Identifier ;
- Subscribed tariff ;
- Subscribed intensity ;
- {Blue, White, Red} days {Low, High} hours meter index
- Current tariff period ;
- Tomorrow’s colour ;
- Instantaneous intensity ;
- “Over Subscribed Power” Notice ;
- Maximal intensity ;
- Apparent Power ;
- Data collection periodicity of the “listener” ;
- Time range data collection of the « listener ».

These state items are the Agent – Electricity Meter interface messages, which are directly derived from the corresponding state items:

- getElectricityMeterIdentifier ;

- getSubscribedTariff ;
- setSubscribedTariff ;
- getSubscribedIntensity ;
- get{Blue, White, Red}Days{Low, High} Hours Meter Index ;
- getCurrentTariffPeriod ;
- getTomorrowsColor ;
- getInstantaneousIntensity ;
- getOverSubscribedPower ;
- getMaximalIntensity ;
- getApparentPower ;
- getAllMeterIndexes ;
- setDataCollectionFrequency ;
- setTimeRangeDataCollection ;
- sendOverSubscribedPowerNotice.

## **Agent - Watcher Interface**

The Agent-Watcher Device interface allows the Agent to collect energy consumption readings for all the “dumb” appliances in the house (appliances which are not smart ones). Without this kind of metering device, the Agent would only be able to report the aggregated consumption of the smart-grid enabled (native) devices, or the aggregated energy consumption provided by the home smart meter.

Even when all the electrical appliances are smart-grid enabled, the Watcher device can be used to provide the authoritative figure for the consumed energy. It also provides confirmation and a sanity check when comparing it against the readings of the various Appliances.

The Agent uses this information to report (display) to the end-user (via the GUI), and, more importantly, as an input to its own calculations and decision making processes, and also to report to the Supervisor.

The interface between the Agent and a Watcher device is uni-directional. All requests originate from the Agent and are directed towards the Watcher. Note that the “messages” as defined in the appendix can carry return values.

The Watcher relevant “state items” are the following:

- energy consumed (in Wh) ;
- maximum supported value (maximum reading that can be reported - before overflowing and folding up) ;
- current instantaneous power (in W) ;
- On/Off output power ;
- Reset of the ‘energy consumed’ value ;
- Periodicity of instantaneous Power measurement ;
- Time range data collection of the Agent.

These state items are the Agent – Watcher interface messages, which are directly derived from the corresponding state items:

- GetEnergyConsumed ;
- GetMaxSupportedValue ;
- GetCurrentPower ;
- GetLog ;
- SetDeviceOn ;
- SetDeviceOff.
- ResetEnergyConsumedValue ;
- setPeriodicityPowerMeasures ;

- SetTimeRangeDataCollection.

## **Agent-Supervisor interface**

The Agent-Supervisor interface is used:

- A. by the Supervisor to send energy consumption-related instructions or requests to the Agent or to advise for special events (e.g. “there is a planned power outage between 18:00 and 19:00”).
- B. by the Agent to report past energy consumption statistics and present data (status) to the Supervisor. This reporting functionality might take place either on a periodic basis (e.g. daily) or in response to the Supervisor requesting specific information. Clearly as part of the Agent’s specification, a decision has to be made on the period of time for which the Agent will need to store data/statistics.
- C. by the Supervisor to update the Agent software or install patches and for general provisioning

A case could be made that from a functional perspective, the third functionality is quite different than the other two and that we could visualize two Agent-Supervisor interfaces:

- A bidirectional Agent-Supervisor interface comprising functions A) and B) above
- A uni-directional Supervisor->Agent interface for the provisioning function (C)

## **Agent-BSS interface**

- The Agent-BSS interface (interface #5 in the diagram of Figure 34) is used by the Agent to collect statistical information and energy consumption analysis, and possibly, prognostications, made by the BSS software. It will be a file-based interface.

- In the other direction the BSS will use the interface to obtain consumption information from the Agent. It remains to be decided whether the BSS module will read consumption information: (a) from the Agent, (b) independently from the intelligent metering device, (c) effectively from the intelligent metering device but via the Agent, or (d) a combination of the above.

## 2.7 ICT for the Supervisor

### 2.7.1 Requirements for the Supervisor

The supervisor has two main targets. The first target is to aggregate the consumption patterns as reported by the Agents and report them back to the service provider and the second to remotely control Agents in order to avoid, as much as possible, energy demand peaks. Some of the features that the Supervisor should include are:

- **Scalable Architecture:** The supervisor must be able to monitor and control multiple Agents (order of thousands) and therefore its architecture should support almost scalability.
- **Dynamic mapping of Agents to Supervisors:** Together with scalability, the architecture should allow easy re-grouping of the Agents controlled by various Supervisors. This will be useful to accommodate, e.g., changes in the regional organization or maybe to utilize the availability of more powerful Supervisors that can handle many more Agents. Of course, as noted before, the Supervisor architecture, from a communications and algorithmic / database perspective will be scalable but the Supervisor itself will likely need a human operator to oversee it (e.g. maybe look at the screen, read messages, respond to emergencies and so on).

Depending on the business models, this might set a limit to the amount of Agents (i.e. households and other installations) that a single Supervisor can control. Future



business models may invalidate this planning which is why it is necessary to allow for easy re-grouping of Agents / Supervisors. In contrast to the Agent, the supervisor is owned by the service provider and not the end user. Therefore, its cost is not a critical factor as in the case of the Agent. Other requirements, such as an intuitive user interface and ability for automatic upgrades apply to Supervisor, too.

## 2.7.2 Supervisor Specifications

The requirements for the Supervisor can be considered in the context of the following topics:

- **interfaces with other entities of the smart grid.** These interfaces define the “physical boundary” of the supervisor. Additionally, as a logical consequence of the services that can be provided or of the actions that are available through these interfaces, a “functional boundary” is also established. The actual functional requirements should then clearly fall within the possibilities available as part of that “functional boundary”
- **functional requirements.** As noted above, these are constrained by the actual interfaces offered by other smart grid entities and by the services, information and actions they can provide or support.

These requirements are driven from the actual scenarios that this entity is expected to support. Based on these scenarios, and on additional inputs, the requirement classes identified above can be defined in greater detail.

A supervisor has to aggregate the lower hierarchy layer “Agent” consumption patterns and is able to remotely control their consumption based on the network conditions, the electricity requirements forecast and the customer contract. Also it should be able to be installed at building, square or neighborhood level. Lastly it should mediate between the Agents and the Service Centre

### **2.7.3 Electricity Company - Supervisor interface**

Through this interface, operations personnel at the Electricity Company can monitor the power consumption figures, trends and past historic information supplied by a number of Supervisor entities. Through the same interface, actions can be initiated on selected supervisors. Such actions might be, for instance, to advise Supervisors of a planned power outage or to request a reduction of the aggregated energy consumption for a given time period. It is then the responsibility of the Supervisors to translate that broad request into more specific energy-related requests that are disseminated to specific houses in the supervisor's area of control (e.g. neighborhood) through the Agents. The agents then, in turn, translate the aggregated house energy figures to instructions to specific smart-devices.

### **2.7.4 Web services**

The Energy Management Service will run remotely and will include all the modules which will manage the information coming from the user's Home, from the Agent and Supervisor, from the Utility, and also from the User directly (through the GUI). The logic for this service is to be able to easily communicate with the different modules, such as the Supervisor, portals and APIs. The Service Portals will include direct and indirect software modules in order to organize correctly all the data flows and functionalities. The software architecture of the Energy Management System will be based on APIs offered via Web Services.

### **Electricity Provider Front-End**

- Service registration
- Contract alternatives specification (tariffs, possibility of buying user's electricity, etc.)
- Statistics and information about each contract type users, consumptions (instantaneous and historic)
- Peak control graphics
- Notifications/commands section (to Supervisor).

## End User Front-End

- Service registration, information about different utilities, types of contract, tariffs, etc.
- Multi-user ability for different family members depending on necessities
- Agent Front End – User required inputs
- Devices and users profiling
- Appliances and devices management, consumption and CO2 emissions information.

These assumptions are based on the idea of a supervisor as a logical unit that can control several agents, and also other supervisors, like in a tree structure.

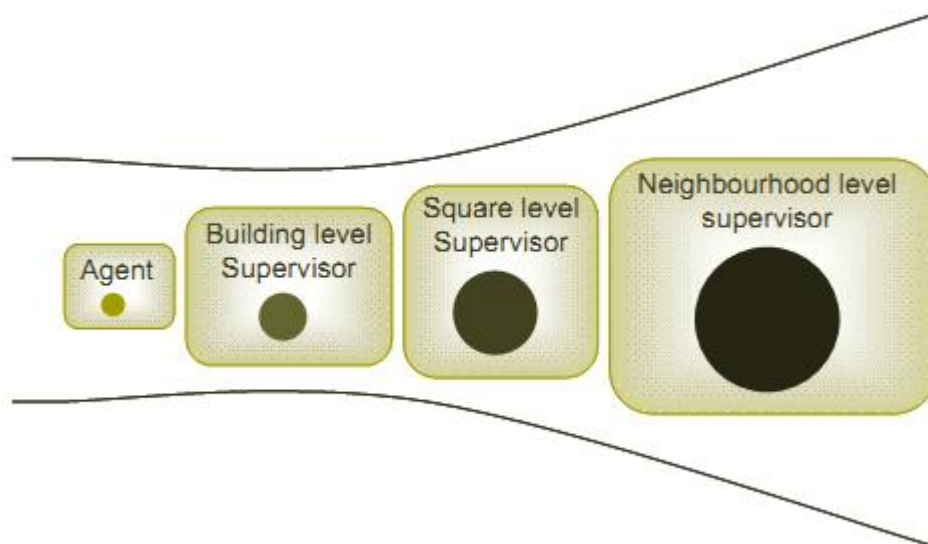

Figure 10 - Supervisor hierarchy

The user might be interested in optimizing consumption and costs, selling the extra energy generated by the photovoltaic (PV) system to the national grid, taking advantage of different utility promotions and other actions that can be profitable for both of them. The utility might consider offering personalized services to several end-users, or to an entire residential area or a neighborhood. To do so, it might collect

information about users' preferences and suggestions, predict consumption peaks, or be able to notify end-users about any relevant information.

## **2.8 Key initiatives**

### **2.8.1 Home Gateway Initiative (HGI)**

The Home Gateway Initiative is an open forum launched by Telcos in December 2004 with the objective to build specifications for a residential gateway. In addition to Telcos, several manufacturers have joined the alliance. HGI was created to boost the market of home communication services to the millions of broadband customers served by its founding members. The initiative will drive the development of residential gateways supporting several services [6]. In May 2008, the HGI announced a move towards energy efficiency. It will be working towards a set of specifications that will outline energy saving solutions for a home gateway. Representatives of the worldwide industry member companies will gather in March 2009 at HGI's 13th quarterly meeting, in Florence, Italy, where the topic will be high on the agenda.

The HGI will derive its specifications from the EU Code of Conduct on Energy Consumption of Broadband Equipment, which sets out the basic principles to be followed by any party involved in broadband equipment, operating in the European Community, in respect of energy efficient equipment. Like any other international consortium, the HGI will be working closely with Standard Developing Organizations, including ITU-T and ETSI (TISPAN and AT-TM), who are already working on this important topic [7].

The European Commission has included recommendations from the Home Gateway Initiative (HGI) for version three of the Code of Conduct on energy consumption of broadband equipment. In line with the recommendations that were made, the HGI is now working on specifying low power mechanisms that allow the home gateway to consume the minimum power corresponding to its current level of

activity, by looking at the individual subcomponents and assessing the existing power modes, and evaluating the implementation of additional low power modes. The work of the HGI on energy efficiency also extends deeper into the home network, involving the home gateway unique role as a continuously operating device, orchestrating home automation [8].

## **2.8.2 ZigBee Alliance**

The ZigBee Alliance is an association of companies working together to enable reliable, cost-effective, low-power, wirelessly networked, monitoring and control products based on an open global standard. The goal of the ZigBee Alliance is to provide consumers with ultimate flexibility, mobility, and ease of use by adding wireless intelligence and capabilities into everyday devices. ZigBee technology will be embedded in a wide range of products and applications across residential, commercial, industrial and government markets worldwide. For the first time, companies will have a standard-based wireless platform optimized for the unique needs of remote monitoring and control applications, including simplicity, reliability, low-cost and low power [9].

In 2008, the ZigBee Alliance moved towards more interest in energy management with the launch of the ZigBee Smart Energy public application. The ZigBee Smart Energy application is a ready-to-use solution offering utilities and technology suppliers a secure, interoperable, easy-to-use wireless global standard for developing products that improve energy management and efficiency for both consumers and service providers. The ZigBee Smart Energy application was developed through collaboration between innovative utility companies, product manufacturers and technology suppliers in response to demand for a global wireless standard for better energy management. It enables wireless two-way communication between utility companies and common household devices, empowering consumers to manage their energy usage more precisely.

The ZigBee Smart Energy application allows utility companies to implement more sophisticated programs for greater energy management, and to respond to governmental objectives in terms of energy efficiency. Prior to that, in May, the Alliance certified 19 ZigBee Smart Energy products [10].

### **2.8.3 IPSO Alliance - IP for all Devices**

Sensors for light, pressure, temperature, vibration, actuators, and other similar objects evolve; new applications and solutions are being created and implemented. Indeed, the Smart Grid, “smart cities”, home and building automation, industrial applications, asset tracking, utility metering etc. are all taking of IP’s rich history and adaptability. The IPSO Alliance<sup>26</sup> was formed in August 2008 with the objective of continuously increasing the base to support and supplement the IP on every device. The IPSO alliance will perform interoperability tests, document the use of new IP-based technologies, conduct marketing activities and serve as an information repository for users seeking to understand the role of IP in networks of physical objects. The IPSO goals are: Promoting IP as the premier solution for access and communication for smart objects. Promoting the use of IP in smart objects by developing and publishing white papers and case studies and providing updates on standards progress from associations like IETF among others and through other supporting marketing activities. Understanding the industries and markets where smart objects can have an effective role in growth when connected using the Internet protocol. Organizing interoperability tests that will allow members and interested parties to show that products and services using IP for smart objects can work together and meet industry standards for communication. Supporting IETF and other standards development organizations in the development of standards for IP for smart objects. The IPSO alliance has published several papers on IP technologies for embedded devices (including smart meters) as well as energy efficiency e.g. in commercial buildings.

## **2.8.4 HomePlug Alliance**

The HomePlug Powerline Alliance is an industry-led initiative established to create specifications and certification logo programs for using the power lines within homes for simple, reliable networking. The Alliance accelerates worldwide adoption for HomePlug technology through market development and user education programs. Among its specifications, the HomePlug Powerline Alliance has designed a standard for Command & Control (HomePlug C&C), suited to home automation, and thus energy management. The HomePlug® C&C standard is Green Tech enabled, offering communication and networking for a nearly unlimited variety of command and control applications including AMR/AMM/AMI as well as other Smart Grid applications such as Peak Demand Control. The result is a more efficient use of resources ensuring less environmental pollution as well as consumer friendly incentives such as low tariff periods, competitive pricing, more accurate billing and so forth.

Recently, the HomePlug Powerline Alliance announced that the Electric Power Research Institute (EPRI) is now collaborating with them to develop a common language for home area network (HAN) devices to use advanced metering infrastructure (AMI). The groups will work in cooperation with the many utilities already supporting ZigBee Smart Energy solutions and will look for ways to further expand the Smart Grid concept by creating a standard communication approach between AMI systems and HANs, as well as a common set of certification procedures. The initiative will enhance the capabilities of ZigBee Smart Energy solutions to incorporate new features, support wireless ZigBee and wired HomePlug devices, and accelerate the development and certification of HAN devices capable of plugging into a Smart Grid devices such as thermostats, pool pumps, water heaters, appliances and plug-in vehicles [11].

## **2.9 Networks and protocols**

## General requirements for communications

- **Low cost:** Indeed, low cost allows the technology to be widely deployed in wireless control and monitoring applications. The evaluation and validation of low cost communication will include both Powerline and wireless media (based on IEEE 802.15.4 standard or any equivalent standard) and protocols, proposed by the Home Gateway Initiative (i.e. HGi) for machine to machine (M2M) communications.
- **Low power:** The in-home communication system will integrate low-power communication solutions, based for instance on IEEE 802.15.4 standard for WPAN (Wireless Personal Area Network) [12]. Even if transfer rates are said to be “low” (about hundreds Kbits/s per channel), the resulting effect on power consumption has to be considered: indeed, the low power-usage allows longer life with smaller batteries which is a requirement in projects targeting energy consumption reduction. Power consumption reduction can be much more consequent according to the implemented protocol and network architecture. Indeed, in some networks, power consumption is definitely irregular: some devices are always active, while others spend most of their time sleeping. Since the amount of energy is limited, it must be used carefully and in an optimal way.
- **High level of security:** The policy adopted by the network to prevent unauthorized access by unknown parties is known as “network security”. Since the communication medium may be in the form of Radio Frequency (i.e. RF), it may be more subject to attacks compared with a wired network, because of the nature of the transmission medium. This may be a reason why the in-home network must integrate a high level of security (reference: IEEE 802.15.4 security mechanisms). Some of the basic features that should be provided by the link security control areas are:
  - Authentication ;
  - Message confidentiality ;



- Message integrity.

For instance, the security management system could authenticate the different actors of the network (e.g. appliances or communicating devices, or operators) with any kind of adequate credentials. In this way, unauthorized entities will not be part of the in-home network and hence will not be able to take control of communicating devices. Specific nodes/devices should be able to detect messages coming from unauthorized nodes and must thus reject them. On the other hand, messages confidentiality can be tackled by means of typically achieving encryption (such as AES, or any encryption algorithm adequate for embedded systems). Encryption mechanisms must prevent an opponent from learning information included in the exchanged messages. Mechanisms that cipher plaintext and messages should be integrated and will result in different cipher texts that can be read by nodes informed of the way by which messages have been ciphered. Finally, message integrity can be carried out by detecting message tampering. A message is said to be tampered when an adversary modifies a message while the message is in transit. Process such as message authentication code (i.e. MAC) allows networks to notice message tampering.

- **Widely used communication standards:** Since connectivity turns out to be a key factor for newly developed energy-aware systems, it is necessary to use widely spread standards that will support a wide variety of purposes such as cost management, entertainment, security and energy systems automation and control.
- **Plug and play installation:** The smart-grid architecture must be easily extendable so that more and more devices, provided by different manufacturers (multi-sourcing), can be connected. The goal of Plug-and-Play middleware technology (such as UPnP) is to allow devices or appliances to connect seamlessly and to simplify the implementation of networks in individual homes for data sharing and communications [13]. Such kind of middleware technology allows networks to be extended by a technology that dynamically attach appliances to the Agent platform. Plug-and-Play middleware

technology will also enable wider, vendor-independent application-level ubiquitous networking (intelligent appliances identification) and devices/services automatic discovery (that requires the design of a UPnP control point).

## **Communication protocols specifications**

The technical trends of Home Area Network turn out to converge towards IP-enable networks and devices. Indeed, last press releases (April 2009) of ZigBee Alliance [14], IPSO (i.e. IP for Smart Objects) and the CAP (i.e. Compact Application Protocol) workgroup clearly mentioned [14] the will to implement IP-enable solutions (IPv6) over Home Area Networks. IP-enable solutions are the main solution able to provide network interoperability between smart devices, from different brands of manufacturers.

## **In-house Networks**

### *Introduction*

At first, it is necessary to differentiate between kinds of buildings. The three most important are: houses already built, new houses and office buildings / large organizations. Not all the technologies are valid for all types of buildings. Some of the technologies described in this section are applicable in industrial buildings and office buildings but are too expensive and complicate for a residential house.

The management of home appliances from the Agent is implemented according to a layered architecture: the lower layer (network layer) depends on the network the appliance is connected to, and then, is specific to the technology used for communications between the appliance and the residential gateway. Upon this layer, there is another one (appliance layer) that implements the access to the functionality

offered for control by the appliance. These two layers are usually very specific to the manufacturer implementation of the M2M technology used for communications and the actual appliances, so are normally bundled into a single OSGi bundle that offers a standard API to the highest layer. The highest layer (application layer) of the architecture makes the control of appliances by the Agent independent from the type of appliance and the M2M technology used to send commands and receive messages from it. In a built house, technologies that do not require the installation of a specific wire for communications between appliances should be used, due to the cost and inconveniences for the end user that the need of a new cabling would involve (great barrier for the adoption of the solution). Thus, only wireless and PLC are preferable.

The next distinction is in done between:

- Fixed home networks
- Wireless home networks

## **Fixed home network alternatives**

### ***Introduction***

Fixed home networks are those that require a wired structure at home level. This infrastructure may already be present and if not, should be extended to interconnect appliances to one another. The most important features that fixed networks provide are more bandwidth and more reliability. On the contrary, the main disadvantage is the possible need to extend wires and the inconveniences this may lead to.

## 2.9.1 X10

X10 is one of the oldest technologies for home automation applications. It was developed by Pico Electronics of Glenrothes in Scotland. It is a communication protocol which sends control signals to home automation devices via the power line, (120 V o 220 V, at 50 or 60 Hz) [15]. The communication speeds are low, at 60bps in USA and 50 bps in Europe. Nowadays, it is one of the most extended technologies, with a great variety of available devices and easy installation and use. As it is a mature technology, X10 products have a competitive cost, and this technology is leader in USA market in homes and little enterprises. It is the best technology for installing a not very complex automation system.

There are three kinds of devices: transmitters, receivers and bidirectional devices. The transmitters send a low voltage signal, which is specially coded over the power line. Receivers can have 256 addresses. When a specific device receives an incoming signal, it responds switching itself on or off. Several receivers can have the same address within the same house. Bidirectional devices on the other hand take the signal sent by the transmitters and are capable of responding and reporting about the successful completion of a command, which can be very useful when the X10 system is connected to a computer program that shows the status of the home automation installation. The transmission between sensors, controllers and actuators are mainly through the grid of housing, but also supports radio interfaces. This provides the advantage of not requiring the laying of new cables to connect different devices.

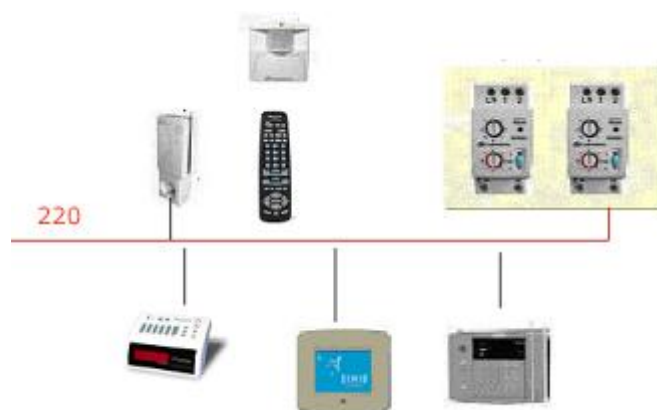

Figure 11 - X10 system

### *Advantages*

The main advantages of X10 technology are that it is the most widely extended, especially in USA market, it takes power from the grid, system installation can be done after house building, little knowledge is required for installation, the system is very robust and most importantly it is low cost.

### *Disadvantages*

Unfortunately only 256 devices can be connected, a very high level of abstraction request cannot be send and transmission speed is generally very low. Furthermore, this network is highly unfit for general purpose communications between devices is not recommended for areas of more than 100 m2 and IP communications are not supported. (expand)

## **2.9.2 LonWorks**

It is a technology owned by the Echelon Corporation [16]. It was introduced in the early 90s and since then many companies are using this technology to deploy control and automation networks. Although it is designed to cover the most control applications requirements, it has only had success in the deployment of office buildings, hotels and industries due to its robustness and reliability. In residential applications its high cost has been a barrier.

It is a solution based on a decentralized architecture, end-to-end, which allows distributing the intelligence between the sensors and actuators which are installed on the housing and it extends from the physical level to the application level of most control network projects. The physical medium of transmission can be twisted pair, coaxial, fiber, grid or wireless. The network is divided into nodes, each of which has a microcontroller that collects network information and sends it to the actuators.

Any LonWorks device or node on the network has a Neuron Chip, manufactured by Motorola and Toshiba. Each Neuron Chip has a 48-bit unique identifier that is recorded in the EEPROM memory when the circuit is built, and allows a direct and secure

addressing to any node in the control network. LonWorks, for the exchange of information (either control or status), uses LonTalk protocol, implemented in the Neuron Chip firmware. This protocol, whose specification is available for any manufacturer, must be supported by all network nodes.

To simplify the message routing, the protocol defines an addressing hierarchy that includes an address, subnet and node domain [17].

- Node: each node is physically connected to a channel. All nodes in a network must belong to the same channel or channels must be connected by bridges.
- Domain: logical collection of nodes that belong to one or more channels.
- Subnet: logical collection of up to 127 nodes within a domain. Up to 255 subnets within a single domain can be defined.

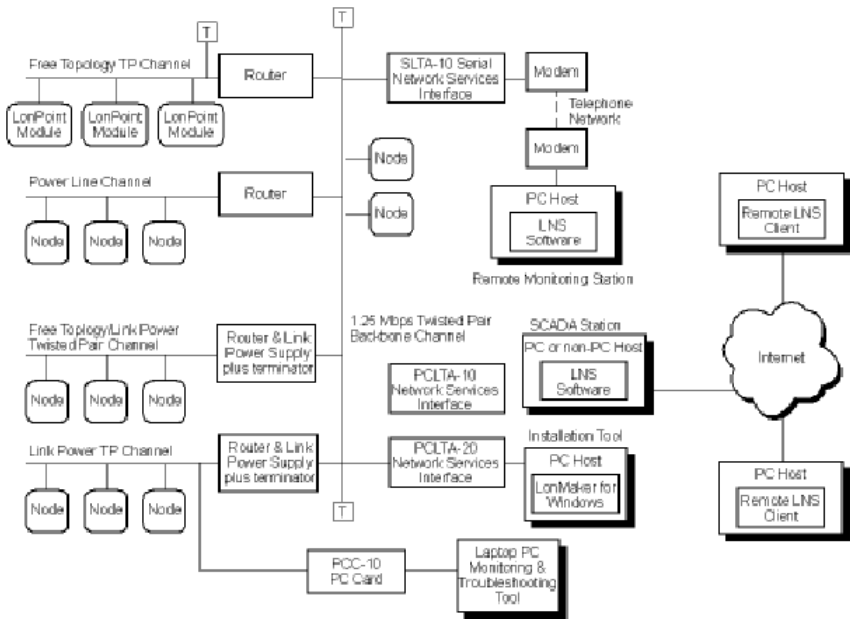

Figure 12: LonWorks Network topology

**Advantages**

Some of the advantages of Lonworks are that it is robust and reliable which makes it ideal for industrial environments. It supports a great variety of transmission media along with an increased range of applications, while the transmission speed remains high.

NodeBuilder, (the development tool) although it has development times shorter than other protocols, the variety of devices it supports is greater.

### ***Disadvantages***

Some of the disadvantages are the low standardization along with a difficulty to integrate solutions from other manufacturers and the fact that it is mostly deployed in the U.S. market

### **2.9.3 HomePlug**

HomePlug [18] is an alliance of several companies working on the development of a technology to implement local area networks using low-voltage wiring of homes, offices or industries, thereby avoiding the installation of new cables. The transmission rates in the first version of HomePlug technology reach 14 Mbps, and it is possible for users to connect to the Internet from any home area that has a standard electrical outlet. Thus, mobility and flexibility that all users need in their daily applications are achieved.

The HomePlug alliance groups over 80 leading companies in sectors such as electronics and information technologies including: Intel, Cisco, Motorola, Panasonic, 3Com, among others.

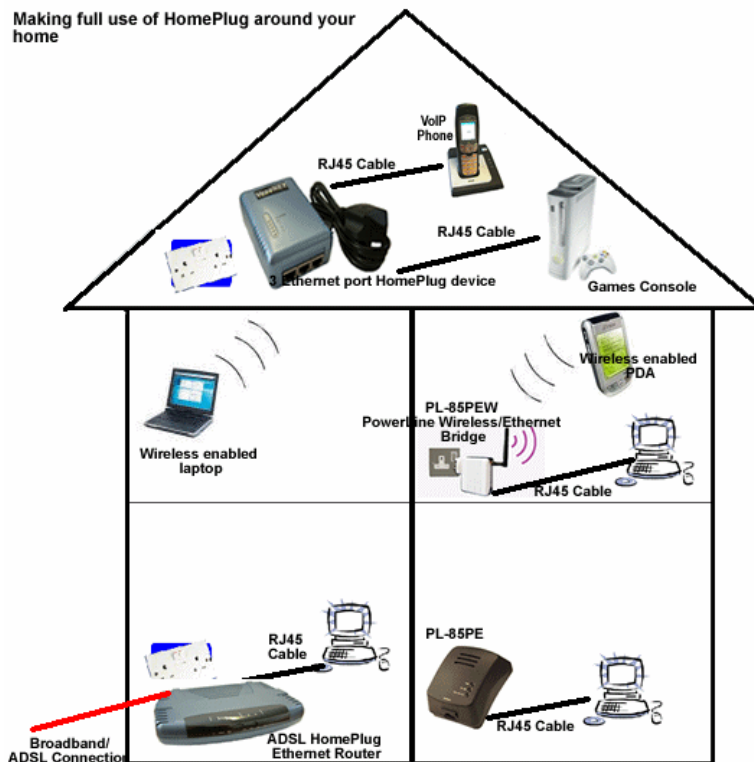

Figure 13 - HomePlug System

For HomePlug installation, it is necessary to deploy a HomePlug circuit, called INT5130 [19]. It is supplied to equipment manufacturers to be integrated into end products such as computers, printers, consoles, residential gateways, set-top TV boxes, among others. HomePlug provides the user the possibility of connecting devices to networks without installing new cables in homes or offices, thus avoiding works in the home. The transmission rate depends on both the topology of the low voltage installation and noise sources, and can have rates of up to 200Mbps.

The main features of INT5130 are:

- Maximum speed: 200 Mbps, is the highest performance integrated circuit in the market. This speed, supports full duplex Ethernet 100BaseT, allows that plenty of Internet applications, like streaming, can operate using the wiring of the house as a communication media.
- High efficiency spectral and bandwidth: HomePlug uses Orthogonal Frequency Division Multiplexing [20] OFDM, modulation similar to that it is used in xDSL



modems which has hundreds of carriers, and implements an adapted control to the medium, meeting to noise and attenuation of low voltage lines. It uses error detection and correction mechanisms, like FEC, forward error correction.

- End-to-end security: with mechanisms similar to those are used in the modem cable industry, INT5130 uses standard of data encryption of 56-bit (DES) to prevent that third users connect to the same low voltage line, for instance users in the same building or in the same street, can decode the information.
- Scalability: INT5130 architecture is capable of transmitting 200 Mbps and it is also compatible with other versions.

### ***Advantages***

The use of Powerline communications in-home has the potential for significant improvements. These enhancements include higher frequency bands, higher level modulations and better forward error correction code.

In addition, there are other specifications, called HomePlug AV+ which will support 600Mbps hence will enable distribution of High Definition (HDTV) multi-streaming entertainment, throughout the home.

Belkin ([www.belkin.com](http://www.belkin.com)) has designed an unofficial gigabit implementation of Powerline

### ***Disadvantages***

Loose connections between cables along with electrical cable quality affect greatly performance and the actual real throughput is nowhere as near to the advertised one. Sometimes if the electrical wire is a low quality one, it may not be able to enable the HomePlug network

## **Wireless home network alternatives**

Wireless networks have experienced a major growth in last years and they have largely replaced the fixed networks, especially in home environment. Wireless networks can be deployed fast since they do not require the installation of a wire infrastructure. During the past they weren't preferred because the available bandwidth and reliability of these networks is lower than fixed networks, but nowadays those features are changing.

### **2.9.4 Wi-Fi**

The term Wi-Fi groups the list of specifications for the IEEE 802.11 standard, (ISO/IEC 8802-11) an international standard that defines the characteristics of a wireless local area network (WLAN). This is a widespread concept that in the last years is growing much more in a household level than wired networks. This technology allows the creation of local area networks both in reduced spaces, or bigger open spaces.

Wi-Fi [21] (which stands for "Wireless Fidelity") is the name of the certification by the Wi-Fi Alliance, formerly WECA (Wireless Ethernet Compatibility Alliance), a group that ensures compatibility between devices that use the 802.11.

With Wi-Fi high speed wireless local area networks can be created. A great deal of devices such as laptops, desktops, personal digital assistants (PDA) or any other type supports Wi-Fi, which offers high speed data rate (54 Mbps or higher) within a radius of several dozens of meters in indoor environments (20 to 50 meters in general) or within a radius of hundreds of meters outdoors. The Wi-Fi providers are starting to cover areas with a high concentration of users (such as train stations, airports and hotels) with wireless networks. These areas are called "local area coverage".

The 802.11 standard provides lower levels of the OSI model for wireless connections that use electromagnetic waves, for example:

- The physical layer (sometimes abbreviated like "PHY") offers three types of encoding information. It defines also the radio waves modulation and the signal features for data transmission.
- The data link layer comprises two sub-layer: Logical Link Control (LLC) and media access control (MAC) layer. It defines the interface between the bus equipment and the physical layer. Particularly, it defines an access method similar to be used in the Ethernet standard, and the rules for communication between stations on the network

There are several types of hardware that can be used to implement a Wi-Fi wireless network:

- The wireless adapters or network interface controllers, NIC, are network cards that follow the 802.11 standard allowing computers to connect to a wireless network. The wireless adapters are available in several formats such as PCI cards, PCMCIA cards, USB adapters and Compact Flash cards. A station is any device that has this type of card.
- Access points, AP, Sometimes referred to as local coverage area. They may allow the close stations to connect to another network through them. For instance, they allow the interconnection between a wired network (typically Ethernet) and Wi-Fi network.
- Wireless routers: devices capable of connecting both wired and wireless networks to a WAN. The 802.11 standard defines two operating modes:
- The infrastructure mode in which wireless clients connect to an access point. This is usually the default mode for 802.11b cards.
- Ad-hoc mode in which customers are connected to each other without any access point.

## *Advantages*

The main advantage of Wi-Fi is that it is the most widespread technology so it is installed in a lot of devices which in turn results in two additional advantages: ease of connecting Wi-Fi devices around the world (because it is a global standard) and reduction in the price of Wi-Fi chipset. (Cause of mass production). Because Wi-Fi is compatible with Ethernet, it allows the extension of LAN networks without using cables, so it can be used in places where it is impossible to install a cable. Security is not an issue today since a strong WPA2 password will keep the network safe in terms of confidentiality. It can also provide QoS for voice and video in real time transmissions, where multimedia services will have priority. Finally it should be noted that there is high level of interoperability between different versions of 802.11, so backward compatibility is covered.

## *Disadvantages*

There are three main disadvantages in Wi-Fi technology: First and foremost today's

Wi-Fi Pollution: as Wi-Fi is a very widespread technology, there may be many access points or devices which are operating in a same area, and can produce interferences that make that the speed connection and the performance drop.

There are only 13 channels in the 2.4 GHz spectrum. Moreover the scope of this technology is not very high in the most extended standards, approximately 100 meters in open spaces. Nevertheless, the IEEE 802.11n standard, which is beginning to spread on laptops, improves this scope. Finally the power consumption is high compared to other wireless technologies, but there is a specification, WMM Power Save, that reduces this problem.

## 2.9.5 Zigbee

ZigBee [22] is an alliance of over 100 companies, with the objective of promoting the development and deployment of a low-cost wireless technology specifically designed for data transmission in sensor networks. Companies like Invensys, Mitsubishi, Honeywell, Philips, and Motorola are working to create a communication radio standard, which is bidirectional in home automation devices, industrial control, or medical sensor. The Members of this alliance justify the development of this standard to fill the void that currently exists both in low cost transmission systems and binary systems, characteristics that are common in most wireless sensor networks.

It is expected that the Zigbee modules are the cheapest wireless transmitters, with an estimated cost of around 2 euros. They have an integrated antenna, frequency control and a small battery. ZigBee offers such an economic solution because the radio can be manufactured with many fewer analog circuits than those normally needed.

ZigBee is a technology that specifies both the hardware and software features. It is based on the IEEE 802.15.4 standard. The most important features of this standard are: network flexibility, low cost and low power consumption.

The standard is used mainly for many applications which require a low rate of data transmission, such as industrial automation system, for example.

The protocol implements the same media access control layer as Wi-Fi or CSMA/CA [23], whereas the physical layer operates in unlicensed spectrum ranges, 2.4 GHz and 868 MHz. All devices should support both active (in which the device creates the RF field and sends the information) and passive mode (in which there is a device that creates the RF field and another device that, modulates the carrier to send the information)

Although the range is, more or less the same as Bluetooth, (about 20m) the main difference is that it can be created networks of 65536 nodes controlled by a primary node.

## Protocol Architecture

The IEEE 802.15.4 standard defines both the hardware and software, focusing on the features of the physical layer (PHY) layer and media access control (MAC) features. The ZigBee Alliance has added the specifications of the network layer (NWK) and application (APL) to complete what is called the ZigBee stack. This architecture can be seen in Figure ;

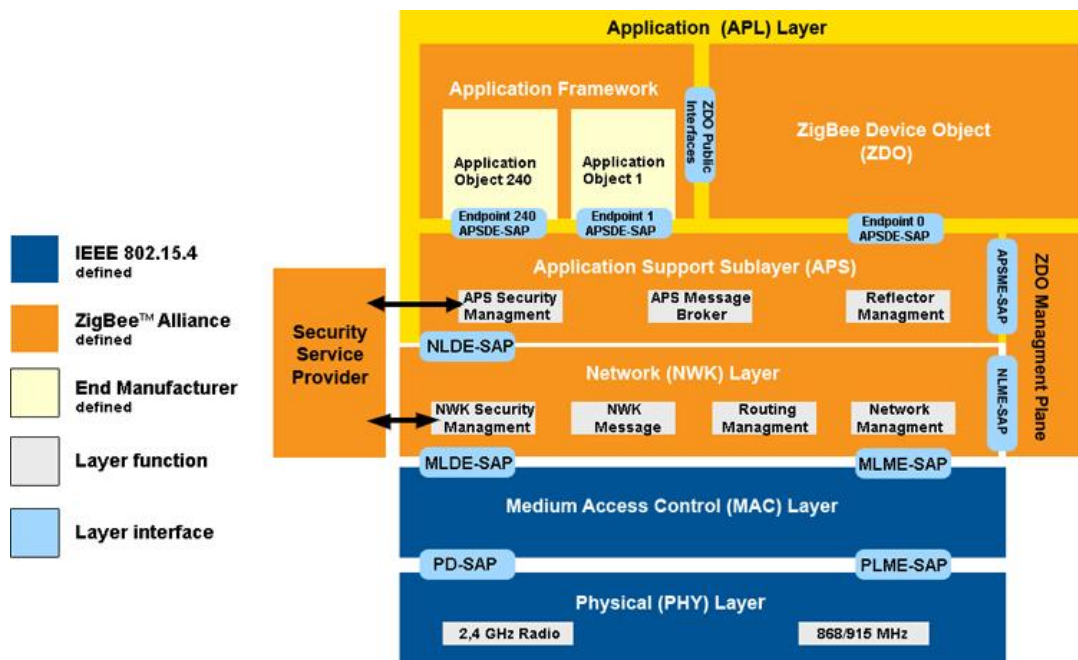

Figure 14: Zigbee Stack

## Future protocols and technologies

### Introduction

The continuous evolution of wireless technologies is empowering the development of new advanced broadband alternatives that are trying to search new features, keeping or enhancing others like high reliability and high data rate. Nowadays, in order to be successful in the design of new systems, it is necessary to use not only technologies that are adapted to the future and will improve the use of Internet, like

IPv6, but also low power consumption features that are necessary to make a system successful .

### **2.9.6 6LoWPAN**

6LoWPAN, an acronym that stands for IPv6 over Low power Wireless Personal Area Networks, is a protocol definition to enable IPv6 packets to be carried on top of low power wireless networks, specifically IEEE 802.15.4 [24]. 6LoWPAN defines how to layer IP version 6 (IPv6) over low data rate, low power, small footprint radio networks (LoWPAN) as typified by the IEEE 802.15.4 radio. It is a standard developed by IETF, Internet Engineering Task Force, for being used in small/Pico sensor networks.

LoWPAN networks are networks that are formed by devices that conform to the IEEE 802.15.4-2003 standard, and their main features [25] were designed bearing in mind low cost (which brings limited computational power and limited memory) along with limited energy availability (which brings short range, low bit rate and low power consumption).

Unlike traditional IPv6, 6LoWPAN deals with packet size incompatibilities in message transport (128 bytes vs. a maximum transmission unit [MTU] of 1280 bytes in IPv6). Today it is a point-to-multipoint architecture and will be augmented with a mesh routing scheme. One of the most outstanding features of 6LoWPAN technology is that it works over TCP/IP suite of Internet. Protocols, which is well understood and widely extended, so 6LoWPAN can take advantage of other protocols in several aspects like: Quality of service requirements, quality of service functions, security framework.

#### ***Advantages***

6LoWPAN technology can be: Stable, well and easily understood and Open. Upon which to build prototypes, pilots, test-bed networks and devices with can be used to cover different environments.

## *Disadvantages*

Some of the main disadvantages of 6LoWPAN technology are described in this section. Most of them are due to the fact that 6LoWPAN technology is relatively new and it is changing continuously.

There are still several areas that are not investigated and explored, for instance like neighbor discovery as well as service discovery, for discovering automatically other sensors or controllers, security (the application of IPsec to those small nodes is not easy) and Life Cycle management, that is, how is the network commissioned and maintained, or how are updates applied to the embedded codes.

## **Wide Area Networks (WAN)**

The data transmission between an Agent and its Supervisor and the utility company is accomplished through WAN networking.

### **2.9.7 DSL**

What are the benefits of using DSL? Because DSL is already widely available, using it speeds up the ability to deploy smart grid technology. And because the networks have already been built, the option is more affordable for a utility than building out its own communications network. Since DSL is a proven technology, it can help smart grid projects gain access to stimulus funds meant for “shovel-ready” projects.

DSL is also high-speed, so if utilities want to use the networks for more bandwidth-intensive services, they can. And DSL is based on Internet Protocol, so it can more easily connect with other IP-based networks and systems, which are ubiquitous. Ultimately DSL is a standard that’s been used for years, so utilities can be rest assured that the technology is highly reliable.



### **2.9.8 BPL**

BPL utilizes electric power distribution wires for the high-speed transmission of data by transmitting high-frequency data signals through the same power distribution network used for carrying electric power to Household users. In a common form of BPL, the broadband connection is provided over the electrical wires that enter a house; a customer can obtain Internet access by plugging a BPL modem into any residential electric outlet served by the BPL system.

It is important to note that BPL technology, in its current form, is not suitable for carrying broadband signals over long distances. The broadband communication channel must be brought into a neighborhood by other means, and then BPL can be used as the distribution mechanism to reach individual homes or businesses.

Carrier-current systems have been used for many years to conduct low-speed data over power lines. Because of the inherent impedance and attenuation variations of power lines, as well as noise from dimmer switches, motorized electrical appliances, computers switching on and off, and other devices, reliable high-speed communication over power lines has been difficult to achieve. However, the recent availability of faster digital processing technologies and the development of sophisticated modulation schemes have produced new designs that overcome these technical obstacles. These new designs have led to the development of new BPL systems that use spread-spectrum or multiple-carrier techniques and that incorporate adaptive algorithms to overcome the problems associated with noise in the power lines.

BPL works by modulating high-frequency radio waves with the digital signals from the Internet. These high frequency radio waves are fed into the utility grid at specific points, often at substations. They travel along MV circuits and pass through or around the utility transformers to subscribers' homes and businesses. Sometimes the last leg of the journey, from the transformer to the home, is handled by other communication technologies, such as WLAN.

Figure illustrates a basic BPL system, which can be deployed in cell-like fashion over a large area served by existing MV power lines by installing multiple injectors, repeaters, and extractors.

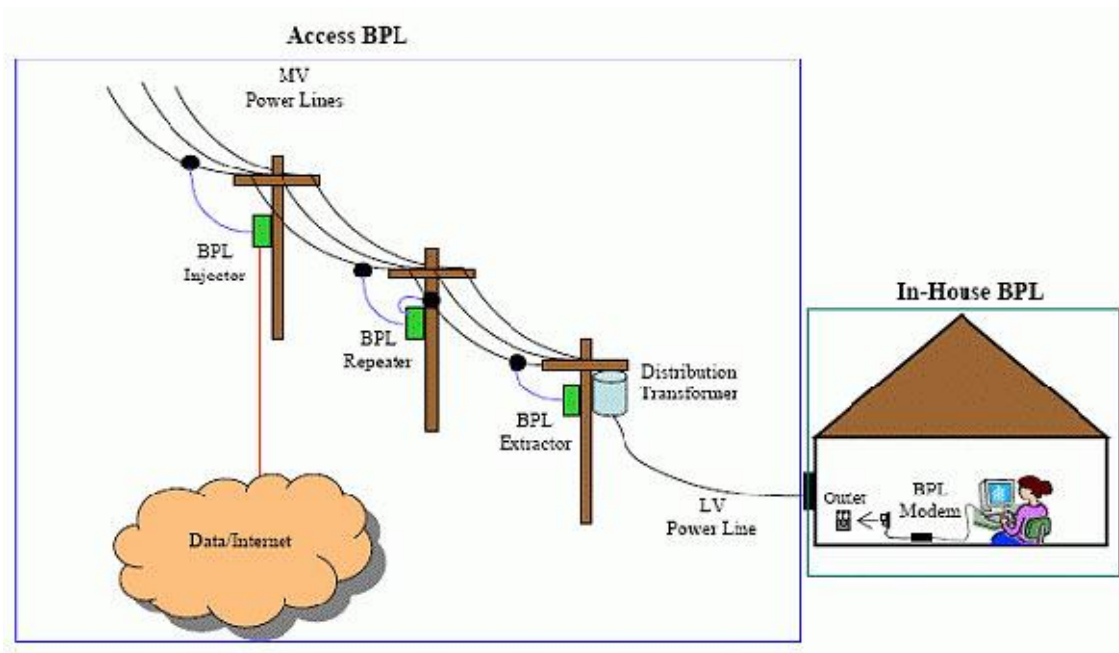

Figure 15 - Schematic representation of a broadband over Powerline system

The main advantages of BPL technology in building the communications backbone that will enable Smart Grids are the ability to touch, reach and digitize the physical grid. Creating the most robust communication network requires that it touches the key nodes, like transformers on the physical grid, and tackle the true complexities of the grid at the outset.

Drawbacks with using BPL to backhaul data are cost of fiber, installation labor cost and the fact that, should a fault occur on the conductor that the BPL services are provided, all data would be cut off and the communication will be rendered useless.

### 2.9.9 GPRS-3G-UMTS-HSPA-LTE

The coverage of public cellular mobile networks is approaching 100% of civilized areas (at least in Europe). Today, mobile services are available almost everywhere making the cellular infrastructure extremely valuable e.g. for meter reading.

Additionally, the packet-oriented data services can be provided with GPRS or EGPRS (EDGE) enhanced GSM networks. These services provide even higher speeds depending on the link quality.

Similarly to 2G/2.5G technologies, the 3G/UMTS technologies are principally able to provide data-only services suitable for telemetry and metering applications. Mentioned services are normally IP based and packet oriented. For metering applications it is important to mention that operators could offer 3G data services at more economical conditions than 2G services.

Even so, the deployment of today's 3G networks is still far behind 2G, particularly in less populated or rural areas. This may however change in future, since 3G/UMTS is considered a strong candidate to provide broadband Internet access in those areas currently not served by xDSL and cable. This makes the 3G technology a potential candidate for AMI

### **2.9.10 WiMax**

WiMax was intended as a wireless alternative to xDSL and other wired local access solutions in rural areas, suburban or urban areas. Today, WiMax technology provides broadband services to mobile or semi-mobile (nomadic) users, as such is also competing with 3G mobile networks in some areas. The technology itself can support robust transmissions, but for reduced speed trade-off. This is valid to a certain extent, for non-line-of-sight (NLOS) conditions and indoor coverage.

However, it is not likely that the deployment of a dedicated WiMax network solely for the purpose of an AMI can be justified. In other words, it may principally be an option for AMI in those areas where public WiMax services are available (e.g. municipal networks).

# 3 Problem Definition

## Types of Load Management

Load Management actions usually fall within two main categories:

### 3.1 Network load shedding (i.e. Rolling Blackout)

The network load shedding aims at remotely managing some power distribution devices. If a stressed period is sensed on the electrical distribution network, a part of the electrical grid will be disconnected and therefore all the loads connected to the non-powered part of the network will also be bereft of power. This is a deliberately electrical outage as well as a last back up measure in order to avoid a total blackout of the power system. It usually occurs when the demand for electricity exceeds the power supply capacity of the network.

### 3.2 Contractual load shedding

Contractual load shedding relies on an agreement between end-users and the utility. This agreement can be either related to an incentive pricing period and /or to the utility privilege to interrupt services under certain conditions.

#### 3.2.1 Time-of -Use

This pricing method presents opportunities for bill savings through discounts or lower rates as well as higher prices at certain times of the day or even of the year. Time-of-Use contracts enable customers to save money by shifting their consumption from peak times to off-peak times. The end-user decides whether or not to shift its power load consumption. The administrator of the load management program defines

the higher rates days/period according to load forecast based on external temperature or demand. The number of critical days per year is fixed but the actual dates for these days are unknown and communicated to the customers the day before. Such contracts have been designed to discourage end-users energy usage at peak times.

Examples of Time-of-Use contracts: EJP tariff in France or REE in Spain.

### **3.2.2 Dynamic Pricing**

Dynamic pricing [26] tariffs encourage end-users to shift usage in order to avoid peak prices that may vary overtime. Prices are elaborated to mitigate market price risk by linking retail price triggers with market condition and transmitted dynamically to customers. Dynamic Pricing tariffs are designed to discourage energy usage during peak periods. Here again, the customers act as the actuators of the load management program, deciding to shift or not their power consumption from peak times to off-peak times.

Examples of Dynamic Pricing contracts: Real Time Pricing (RTP) and Critical Peak Pricing (CPP).

### **3.2.3 Direct Load Control**

Direct load control implies the integration of electrical devices in the customer's house that are able to manage their consumption (e.g. air-conditioning, hot water tank, swimming-pool pump...). A communication system must also be implemented for transmitting the shedding instructions either wirelessly using radio-frequency channel or wirely using PLC (i.e. Power Line Communication). Direct Load Control offers customers low-cost rates in return for the possibility for the utility to interrupt the service under given conditions and within the limits agreed upon in the contract. Direct Load Control can be performed under frequency-detection (that might be called

Dynamic Demand) or another mechanism that the system operator can rely upon. The direct load control is a unidirectional mechanism since devices used to control loads are unable to report their performance back to the controller.

Example of Direct Load Control contracts: Dynamic Demand, Fast Reserve from EDF Energy.

### **3.2.4 Paid-for-Performance mechanism**

Utilities may compensate participants of Demand Response mechanisms through a 'Paid-for-Performance' [26] scheme. Contributors in 'Paid-for-Performance' schemes receive payments proportionate to their transmitted Response. The Response is usually measured and then verified after the triggering event, which means that a two-way communication system must be implemented for both transmitting Demand and also Response. The operator computes the amount of actuated response by comparing metered electricity consumption against an established customer baseline. On one hand, the calculation of the customer baseline is accomplished by comparing its historic and actual usage. On the other hand, the performance that is used as an assessment tool is computed as the difference between the customer baseline and the actual electricity consumption (i.e. customer response) during the event. The resulting computation denotes the quantity not used that would have been used if the customer would not have participated to the 'Paid-for-Performance' scheme. If the calculations show that the customer did not decrease his energy consumption during the event, then there may be some financial penalties to pay.

Example of 'Paid-for-Performance' mechanism: Demand Bidding, Voluntary Demand Response, ISO New England.

### **3.3 Load Management actions that can be taken at the Micro level (End user)**

#### **3.3.1 Individual load shaving**

Appliances can be considered as real load management tools. The individual load shaving [27] process consists in postponing the starting time of some devices in order to stay under a given threshold that can be part of a Demand Management program. To prevent concurrent activations that would bring to power peaks and losses, load profiles of appliances can be requested to be shifted over the time. The end-user can switch off his appliance and thus can ensure that the threshold is not exceeded. If at a certain time, the total power consumption is below the set limit and also if the time-window is broad enough, the appliance can be activate. Similarly, if at a certain time, the total power consumption is above the threshold or if the time-window is not broad enough, the appliance will be delayed. The scenario depicted below denotes a simultaneous actuation of appliances that leads to exceed the threshold

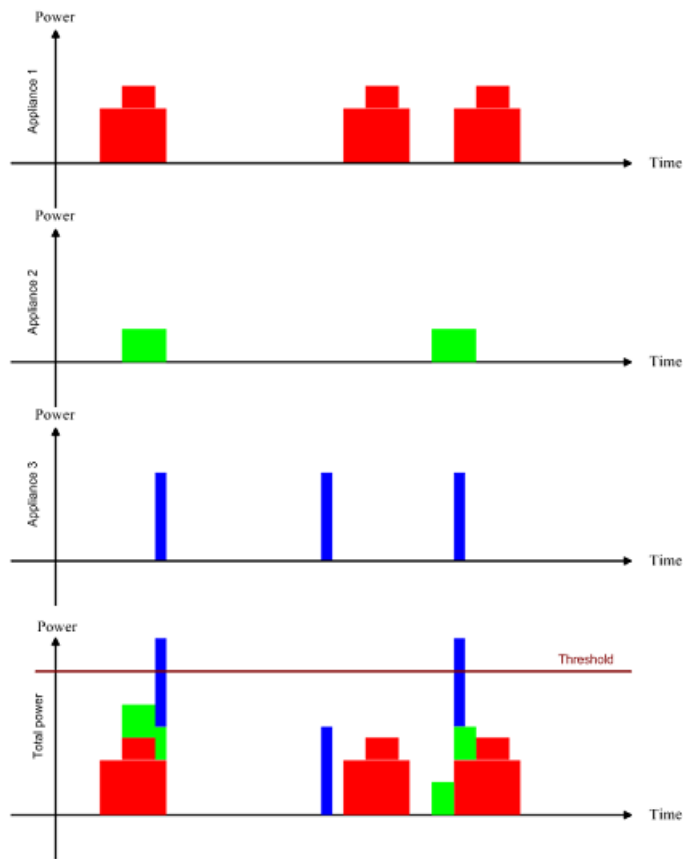

Figure 15- Load Profile exceeding Threshold Value.

As can be seen, the threshold value is exceeded twice, creating peak loads and over-demands. This is the reason why appliances starting times need to be delayed by the end-user so that the total power demand stays below the given threshold. One possible solution can be depicted as follows :



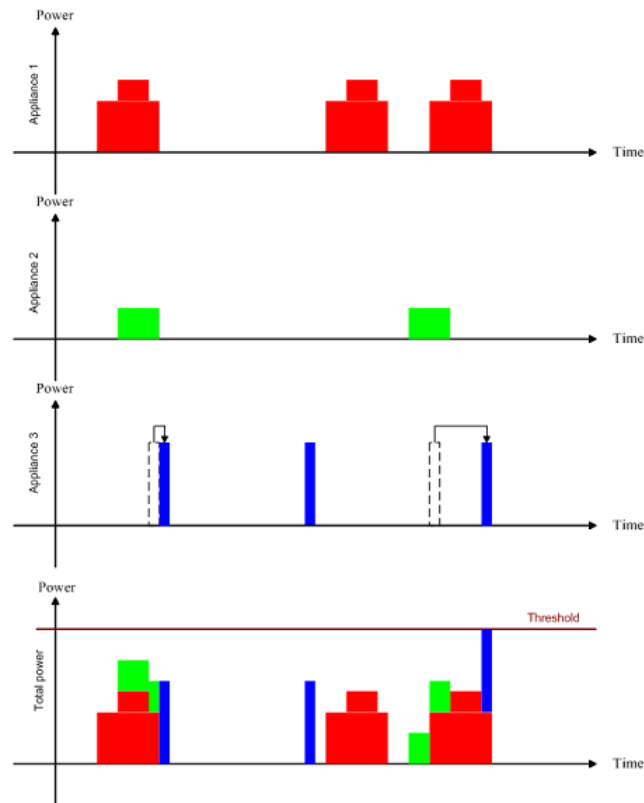

Figure 16- Individual Load Shaving

By postponing the starting time of appliance 3, the total power demand always stays under the set limit value. Although the energy supply efficiency is improved by reducing transmission losses, the home energy consumption is not modified.

**Actions to take advantage of low cost energy periods (heating DHW during off peak periods for instance)**

Another way of using Load Management may consist in taking advantage of low cost energy periods or periods of high-energy production and low demand. Indeed, some mechanisms encourage energy storage in different forms (electricity can be converted into thermal energy that can then be stored) to arbitrage periods of low and high demand (or of low and high prices). For instance, hot water tanks can be heated during off-peak periods taking advantage of such a period (low tariffs) to store energy. This strategy is very suitable for demand leveling and tends to fill the 'valleys'.

# 3.4 Load Management actions that can be taken at Macro level (Utility or Service Provider)

## 3.4.1 Individual Load Shifting to avoid peak loads

Intelligent appliances can be considered as real tools to level and shave peaks. The individual load shifting [27] process consists in postponing the starting time of some devices in order to avoid or mitigate a peak load period. To prevent concurrent activations that would bring to power peaks and losses, load profiles of appliances can be requested to be shifted over the time. The above-depicted scenario denotes a simultaneous actuation of appliances that takes place during peak period:

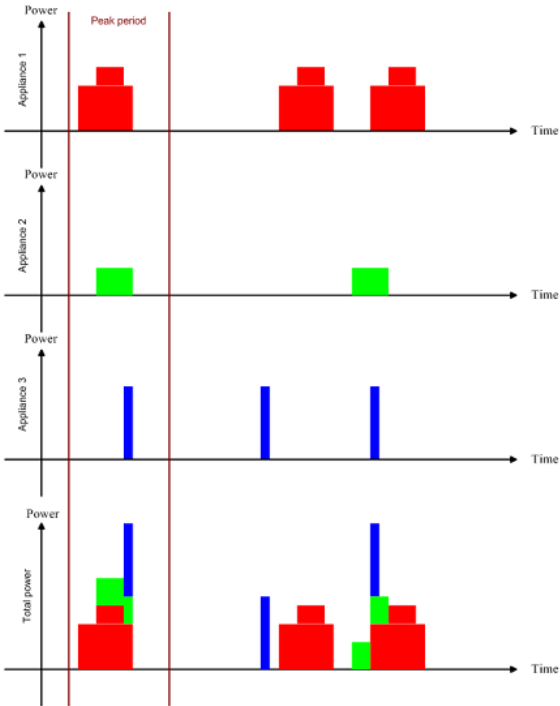

Figure 17- Customer Load Profile during Peak Period

As can be seen three appliances are starting their running cycle during a peak-period. This is the reason why appliances starting times need to be delayed by the service provider in order to mitigate (and to not reinforce) the peak-period. One possible solution can be depicted as follows:

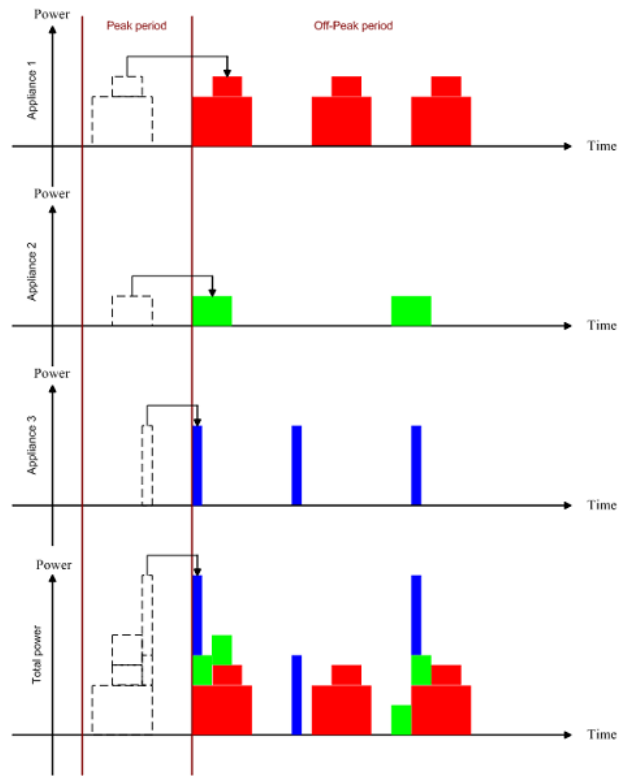

Figure 18- Load shifting from peak to off-peak periods

All the appliances that started during the peak-period have been shifted to the off peak period. It reduces the demand on peak period and thus lowers the risk of blackouts as well as improves the electrical grid reliability. Although the energy supply efficiency is improved by reducing transmission losses, the home energy consumption is not modified.

# 4 Contribution

## Introduction

In order to evaluate the amount of energy that can be saved through load management, different non-critical devices measurements were made.

Later we will apply simulations based on algorithms developed by Dr. George Koutitas in order to estimate the amount of electricity that can be saved in a real time scenario.

## 4.1 Measurements

All measurements were made using a «Plugwise» electricity watcher module which reported the measurement at a two second interval connected wirelessly (through the included usb adaptor) to a standard x86 pc.

### 4.1.1 Academic Assistants' Office Fan Coil

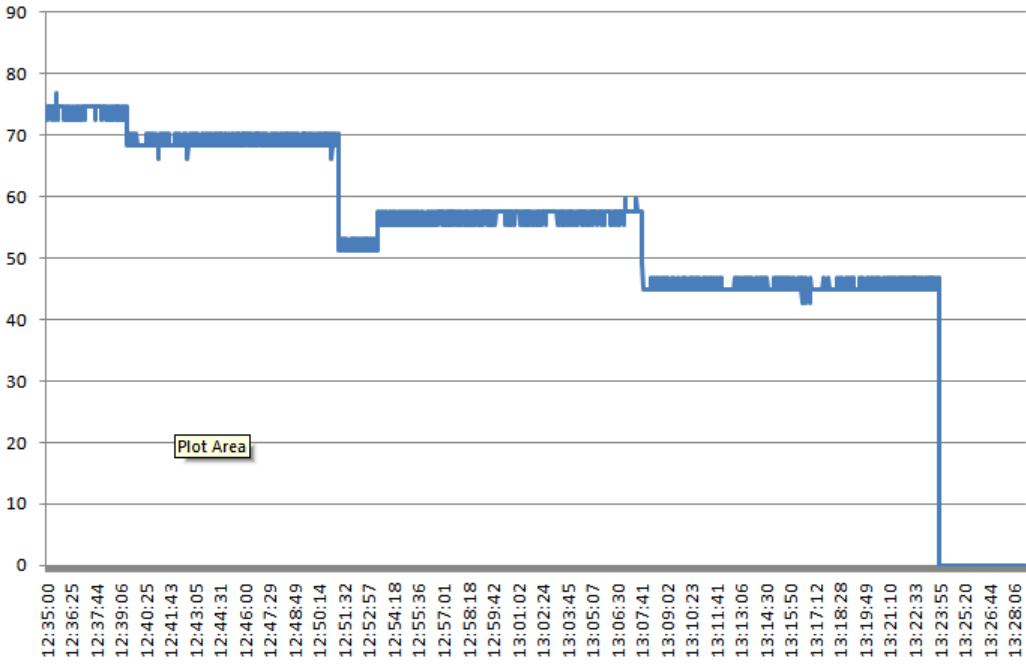

Figure 19- Academic Assistants office Fan Coil Measurement

### *Measurement process*

The measurement started at 12:35 switching the fan coil ant the highest speed three.

- At 12:51 the fan speed switched to two.
- At 13:07 the fan speed switched to one.
- At 13:24 the fan speed switched off to zero.
- At 13:28 the measurement stopped.

### *Observations*

The power consumption of the fan coil is proportional to the speed of the fan. On speed 3 the fan coil consumes on average 70Watts of electrical power. On speed 2 the consumption falls to 57Watts on average. On speed one the consumption falls further to 45Watts on average. When the fan coil is switched off it consumes almost 0Watts of electrical power. Due to simplification reasons, the consumption will be considered fixed and equal to the average of the 3 speeds. Hence it will be:

$(70+57+45)/3 \approx 57$ Watts of electrical power

#### **4.1.2 Corridor Fan-Coil**

One of the fan-coils that is installed in the corridor was measured

The fan coil is of the same type as the one in the office but is shorter thus less powerful.

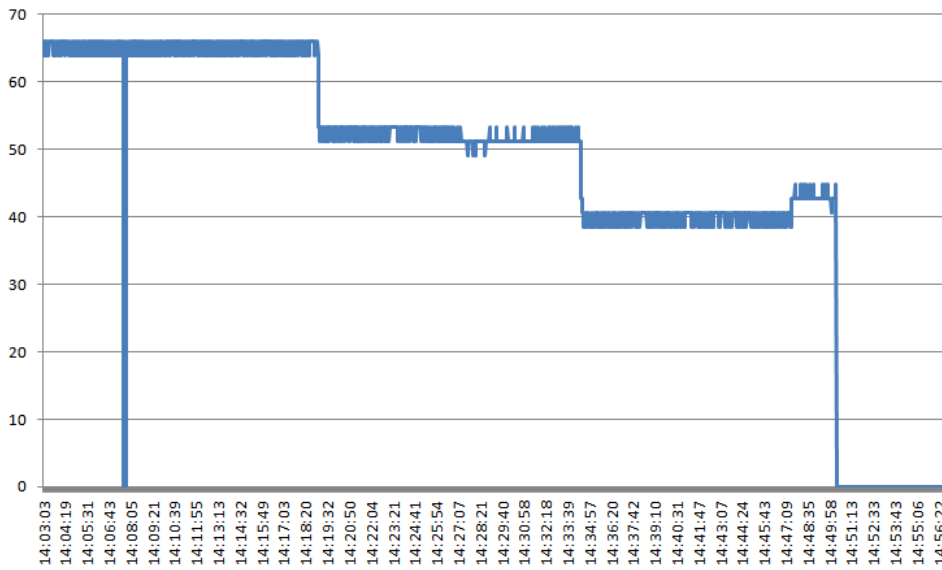

Figure 20- Corridor Fan Coil Measurement

### *Measurement process*

The measurements started at 14:03 switching the fan at its highest speed three.

- At 14:18 the fan switched at speed two.
- At 14:34 the fan switched at speed one.
- At 14:50 the fan switched off at speed zero.
- At 14:56 the measurement stopped.

### *Observations*

The power consumption of the fan coil is proportional to the speed of the fan. On speed 3 the fan coil consumes on average 65Watts of electrical power. On speed 2 the consumption falls to 52Watts on average. On speed one the consumption falls further to 40Watts on average. When the fan coil is switched off it consumes almost 0Watts of electrical power. Due to simplification reasons, the consumption will be considered fixed and equal to the average of the 3 speeds. Hence it will be:

$(65+52+40)/3 \approx 52$ Watts of electrical power.

Even though the corridor fan coil is significantly shorter than the one in the academic assistants office, it consumes (on average only) 5Watts of less power. It seems that the first fan coil is more energy efficient than the shorter equivalent one.

### 4.1.3 Course office fan-coil

The fan coil which is installed in the course office is a new model which features automatic fan adjustment. Thus a long measure was made without any adjustments.

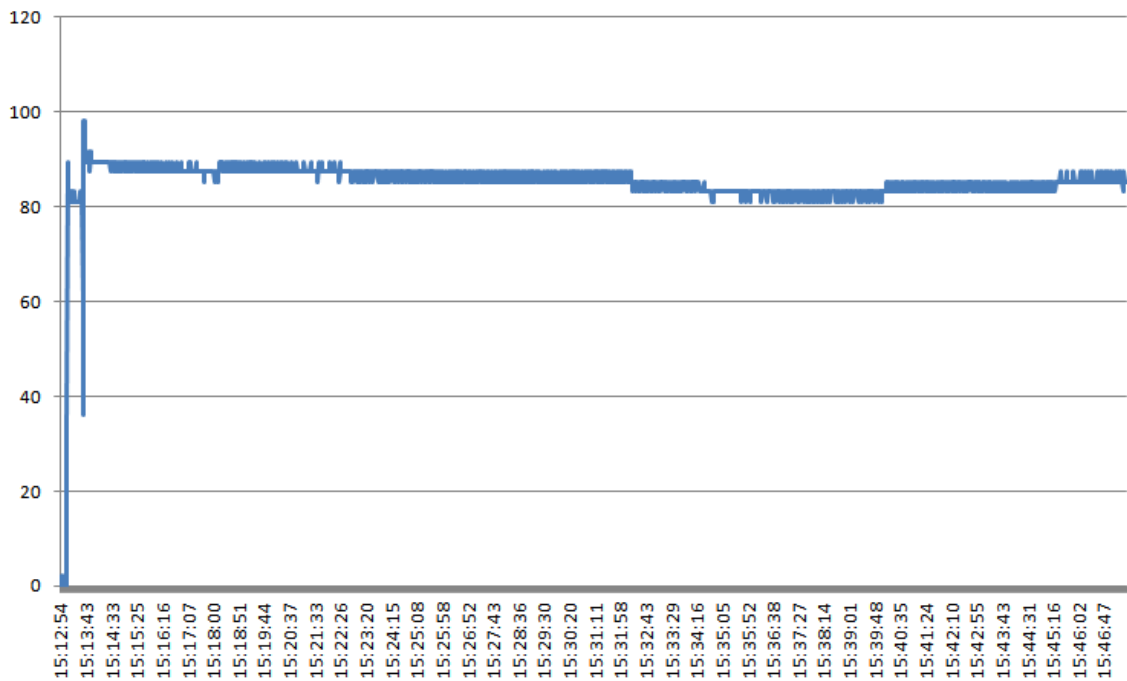

Figure 21- Course Office Fan Coil Measurement

#### *Measurement process*

The measurement started at 15:13 and finished at 15:47

#### *Observations*

The power consumption fluctuates on average between 82-90Watts of electrical power. Due to simplification reasons it will be considered fixed and equal to the mean value, hence  $(82+90)/2 \approx 86$ Watts of electrical power.

It should be noted the large difference in consumption it has with the first fan coil, although both of them are of similar size.

### 4.1.4 Water-Chiller

Power measurement was made while in between we filled 2 glasses of cold water plus 1 glass of hot water

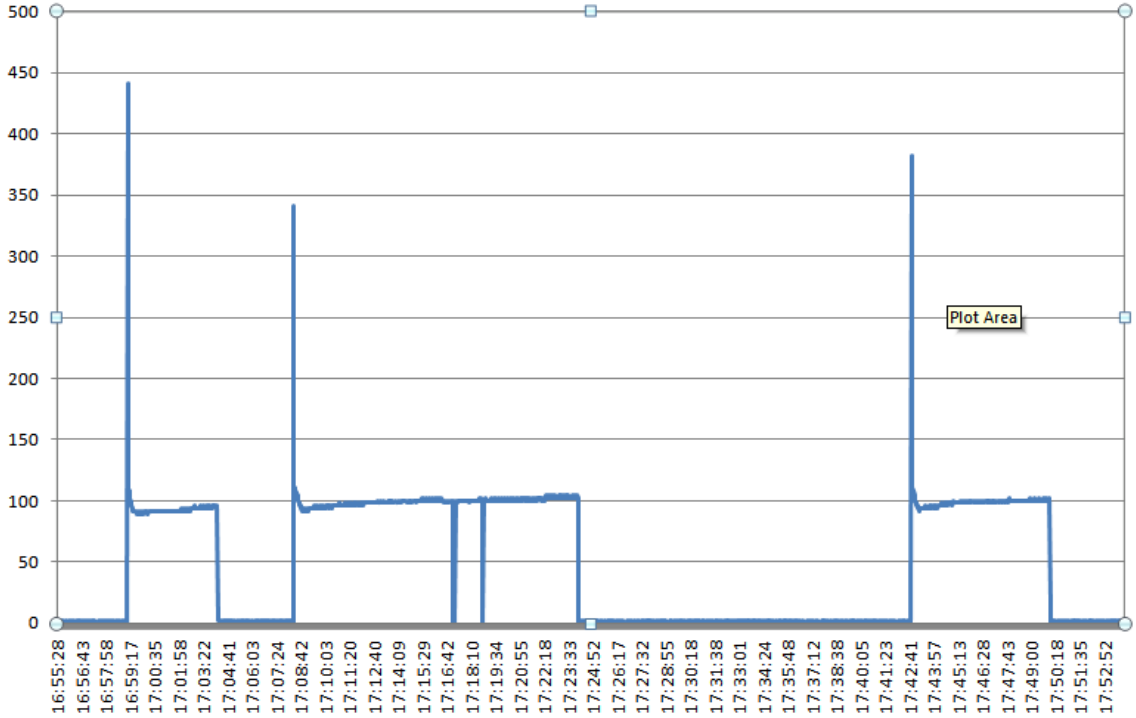

Figure 22- Water Chiller Measurement

#### Measurement process

The measurement began at 16:55

- At 17:07 2 glasses of cold water were filled



- At 17:09 1 glass of hot water was filled
- At 17:53 the measurement stopped

### *Observations*

The power consumption appears to be a step function. This is typical for all devices which contain an electric motor inside (compressor). When I filled 3 glasses of water, compressor remained powered on for a longer time.

### **4.1.5 Fridge**

Power consumption of the fridge was measured without any adjustments

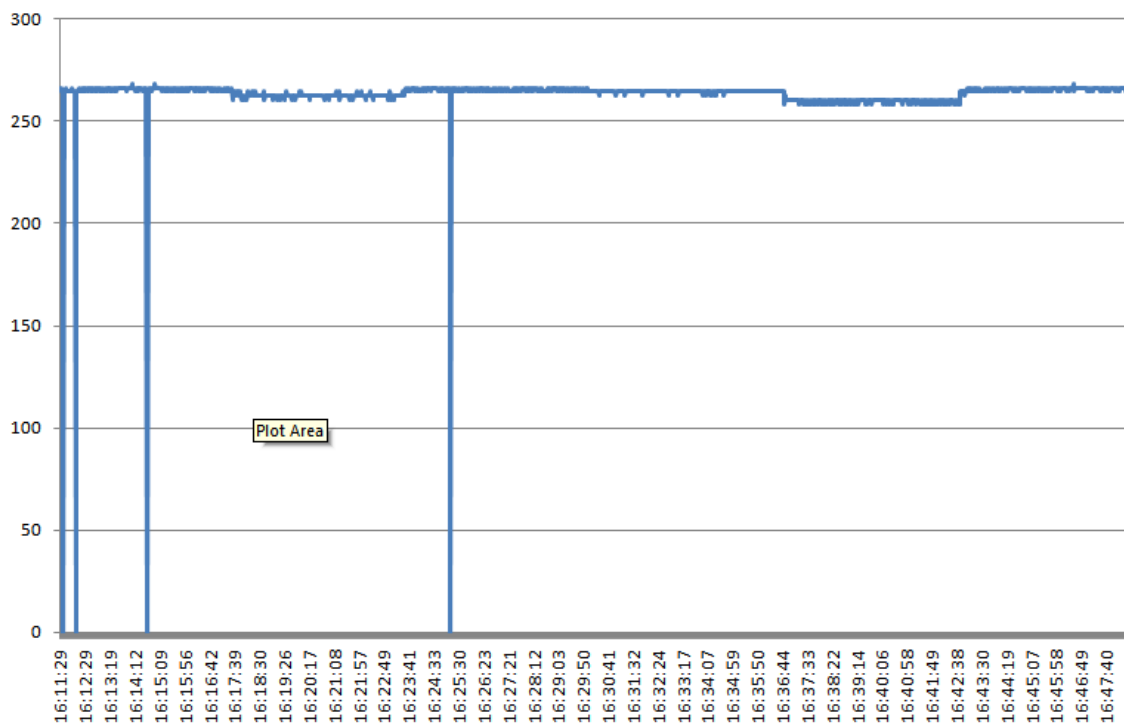

Figure 23- Fridge Measurement

### *Measurement process*

The measurement started at 16:11 and finished at 16:48

### *Observations*

The power consumption remained almost fixed at 265Watts throughout the whole measurement. The compressor didn't switch off at all. That denotes that either the insulation of the fridge is damaged or that the fridge setting was too low.

## **5 Conclusions**

The purpose of home automation systems is to make the occupants lives easier. Managing a system as complex as outlined above without automation will simply not be acceptable. It would remind everybody of the 20th century version of the TV remote and the VCR controls: feature-rich, hard to use, and thus seldom used to their full potential [28]. The goal is that the energy remains as it is today, transparent.

Within the smart grid project, we will consider that end users have two main objectives in mind. Maximizing comfort, (this can often be interpreted as maximizing the level of performance of the device that is used) and minimizing costs. A third objective can be considered to be is minimizing CO2 emissions or minimizing Energy consumption. Usually, not all of tree objectives are compatible: the user will have to give an order of preference for these three objectives.

We will consider also that there exists generally another objective, which comes after the main objectives listed above, which is minimizing trouble, which means that there should be as little constrains as possible. For instance the installation of a new device and its use would be as simple as possible, and should not require any learning period nor the help of an expensive professional.

In general the value of the service as perceived by the customer must be greater than its cost, where the value of the service is the benefit for the customers and the end users that are using the service, in a wide acceptance of the word. Dealing with energy management systems and smart home systems, this benefit may be a greater comfort and a lower energy bill, but it can be also any other satisfaction criteria such as the fact to be more environmental friendly, or to have the up-to-date technology.

On the other hand the cost for the customer is not only the price paid by the customer, but also the price linked to other constraints, such as installation costs or constraints of use. Costs can therefore include both real costs that can be paid with money and other costs that relate for instance to the customer involvement and time spent for installing and operating the device.

Each component of the smart grid should be carefully chosen, bearing in mind power consumption. All this equipment will certainly increase the power consumption of the household. Although the overall power consumption will raise, the utility company won't face a problem handling it, since it will be more evenly distributed across the whole day. Even though each household will increase its power consumption it will end up paying less money to the utility company by taking advantage (automatically) of the reduced off peak hour prices

In many places where smart grid has already started being deployed, consumers are against the project. They think that they will end up paying more for electricity than they do now. Privacy is another major issue. Utility companies will hold too much information about each one individually. Imagine what if that kind of information reaches third ones. That means that confidentiality is of great importance also.

Today it is possible to identify almost all devices that are being used just by having access to the total power consumption curve of a household. Specific devices follow unique patterns that are recognizable inside the curve.

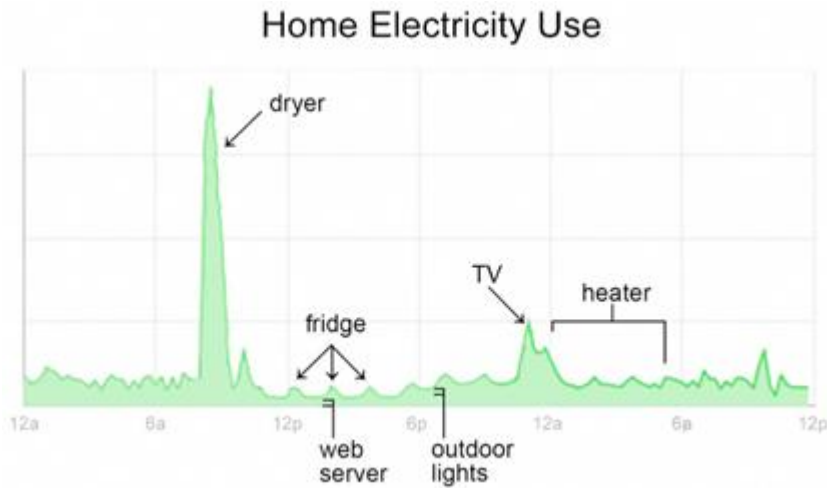

Figure 24- Total household consumption

Today's electricity networks are almost safe from intrusion because all the commands are transferred through closed networks. Smart grid uses the internet to carry all the commands and along with the internet a great level of uncertainty comes. Hackers will be able to power down the whole electricity network sometimes on a national level. They will be able to cause damage also to transformers and other parts of the electricity network. Stuxnet is one such example. It is a worm that was discovered in June 2010. It was characterized as the first weapon made out of code. Its target was the Iran's nuclear program. Experts claim that Stuxnet was only the beginning and it's not a question of "if" but "when" a similar weapon will be used against the electricity grid infrastructure.

## 6 References

[1] Green Paper on Energy Efficiency or Doing More With Less. Brussels, 22 June 2005.

Available at : [http://eur-](http://eur-lex.europa.eu/LexUriServ/site/en/com/2005/com2005_0265en01.pdf)

[lex.europa.eu/LexUriServ/site/en/com/2005/com2005\\_0265en01.pdf](http://eur-lex.europa.eu/LexUriServ/site/en/com/2005/com2005_0265en01.pdf)

[2] Kyoto Protocol To The United Nations Framework Convention On Climate Change.

Kyoto, Japan. 11 December 1997. Available at:

<http://unfccc.int/resource/docs/convkp/kpeng.pdf>

[3] Action Plan for Energy Efficiency: Realizing the Potential. Brussels, 19 October 2006.

Available at : [http://eur-lex.europa.eu/LexUriServ/site/en/com/2006/com2006\\_0545en01.doc](http://eur-lex.europa.eu/LexUriServ/site/en/com/2006/com2006_0545en01.doc)

[4] B. Prindle, M. Eldridge, The Twin Pillars of Sustainable Energy: Synergies between Energy Efficiency and Renewable Energy Technology and Policy, ACEEE Report Number E074, Washington, DC: American Council for an Energy-Efficient Economy, May 2007.

Available at: <http://www.aceee.org/pubs/e074.htm>

[5] North East Pylon Pressure, A Sensible Solution for Transmitting Electricity, All

Energy'08, 2008. Available at: <http://pylon.arconics.com/pdf/46777613.pdf>

[6] Official Website of the Home Gateway Initiative (HGI):

<http://www.homegatewayinitiative.org/aboutus/index.html>

[7] Home Gateway Initiative, HGI puts Energy Saving on the Agenda, available at:

<http://www.homegatewayinitiative.org/press/PR010.pdf>

[8] Official Website of the Home Gateway Initiative (HGI):

<http://www.homegatewayinitiative.org/press/PR011.html>

[9] Official Website of Automated Buildings:

<http://www.automatedbuildings.com/news/jul04/reviews/zigbee.htm>

[10] K Shader, W Liem, ZigBee Smart Energy: The Standard for Energy Efficiency

Available Now, published by the ZigBee Alliance and available at:

[www.zigbee.org/imwp/idms/popups/pop\\_download.asp?contentID=13532](http://www.zigbee.org/imwp/idms/popups/pop_download.asp?contentID=13532)

[11] Official Website of HomePlug® PowerLines Alliance:

[http://www.homeplug.org/news/pr/view?item\\_key=8d1ebf98fe89abf123b692757233f1eb2150a9a9](http://www.homeplug.org/news/pr/view?item_key=8d1ebf98fe89abf123b692757233f1eb2150a9a9)

[12] IEEE 802.15 WPAN Task Group 4 (TG4). Edited by P. Kinney, P. Jamieson, J.

Gutierrez and M. Naeve and published in 2003. Available at:

<http://ieee802.org/15/pub/TG4.html>

[13] UPnP Technology – The Simple, Seamless Home Network. Edited by the UPnP

Implementers Corporation. Available at: [http://www.upnp-](http://www.upnp-ic.org/resources/06150r00UIC_Marketing-UPnP_Business_Whitepaper_electronic_version_.pdf)

[ic.org/resources/06150r00UIC\\_Marketing-](http://www.upnp-ic.org/resources/06150r00UIC_Marketing-UPnP_Business_Whitepaper_electronic_version_.pdf)

[UPnP\\_Business\\_Whitepaper\\_electronic\\_version\\_.pdf](http://www.upnp-ic.org/resources/06150r00UIC_Marketing-UPnP_Business_Whitepaper_electronic_version_.pdf)

[14] ZigBee Alliance plans further integration of Internet Protocol standard. Press

release of the ZigBee Alliance published in April 2009. Available at:

<http://www.daintree.net/downloads/news/090427-za-ietf.pdf?04689c51410dea3ab5cc32b2b01c7ae7=a38a15db6f5b4dcd4d7fc310c5bfb08a>

[15] D. Harder, J. Hayden, J. Kientz, W. Power, Dr. Khawaja Saeed, HOMATION: Design

and implementation of a home automation network, MIS 325: Data Communications

and Networking, November 14, 2007

[16] Official Website of Echelon, (LonWorks)

<http://www.echelon.com/communities/developers/lonworks/>

[17] J. R. Moyne, N. Najafi, D. Judd, and Allen Stock, Analysis of sensor/actuator bus interoperability standard alternatives for semiconductor manufacturing, University of Michigan Center for Display Technology Manufacturing Ann Arbor, MI 48109-2108

[18] Official Website of HomePlug

<http://www.homeplug.org/>

[19] CASADOMO, HomePlug; tecnologías del hogar digital,

<http://www.casadomo.com/noticiasDetalle.aspx?c=45&m=164&idm=55&pat=148&n2=148>

[20] M. K. Lee, R. E. Newman, H. A. Latchman, S. Katar and L. Yonge, HomePlug 1.0 Powerline communication LANs-protocol description and performance results, Int. J. Commun. Syst. 2003; 16:(in press) (DOI: 10.1002/dac.601)

[21] Official Website of WiFi

<http://www.wi-fi.org/>

[22] Official Website

[www.zigbee.org](http://www.zigbee.org)

[23] S. Coleri Ergen, ZigBee/IEEE 802.15.4 Summary, September 10, 2004

[24] G. Mulligan, The 6LoWPAN architecture, 6LoWPAN Working Group, Internet Engineering Task Force.

[25] N. Kushalnagar, G. Montenegro C. Schumacher, IPv6 over Low-Power Wireless Personal Area Networks (6LoWPANs):Overview, Assumptions, Problem Statement, and Goals, Request for

Comments: 4919, August 2007.

[26] A. S. Chuang, Demand Side Integration for System Reliability, Power Tech IEEE Lausanne ,Volume Issue , 1-5 July 2007 Page(s):1617 – 1622, 2007. Available at:

[http://ieeexplore.ieee.org/xpl/freeabs\\_all.jsp?arnumber=4538557](http://ieeexplore.ieee.org/xpl/freeabs_all.jsp?arnumber=4538557)

[27] R. Micelli, Energy Management via Connected Household Appliances, published on McGraw-Hill, 2008.

BeyWatch Deliverables material was used as a guideline

SmartHouse/SmartGrid Deliverables material was used as a guideline















