

# New Design of SCM-SAC-OCDMA-FSO System by Using Gain Technique Based on MD Code

Rashid Ali Fayadh

Hashem Jabar

*Middle Technical University, College Of Electrical Engineering Techniques*

[r\\_rashid47@yahoo.com](mailto:r_rashid47@yahoo.com)

[hashem.jabar@yahoo.com](mailto:hashem.jabar@yahoo.com)

Submission date:- 26/3/2018

Acceptance date:-21/6/2018

Publication date:-26/9/2018

## Abstract:

Free space optic (FSO) is a new modern communication system where free space acts as a medium between transverse and they should be in Line Of Sight (LOS) for successful transmission of optical beam. Due to free space medium, it suffers of various interference like [Rain, Fog/Haze, Snow] that can affect on signal performance and lead to reduce the availability and reliability of the communication link. Because of Iraqi desert climate, it is exposed to dusty storm in most time of year more than other regions, so it is important to study the effect of Fog/Haze and find suitable method to reduce this atmospheric effect on the laser beam when it travels to its final point. Spectral Amplitude Coding Optical Code Division Multiple Access (SAC-OCDMA) has become a major area of research in optical communication system. OCDMA allows multiple users to access the system without any contention; Multi Diagonal (MD) code used in system to support large number of users with high data rate. Optical amplifier is added to the system to provide more enhancement and permit to send the laser beam in longer distance and decrease the interference on it. The result of the study shows that the performance of the proposed system is better than the system without amplifier. It can be seen that the BER with minimum visibility (strong Haze storm) reaches to  $8 \times 10^{-12}$ , BER of medium visibility between ( $1 \times 10^{-137}$  &  $8 \times 10^{-137}$ ), BER with high visibility ( $1 \times 10^{-138}$ ) at **1.85 Km** as a transmission distance and **1Gbps** as a transmission data.

**Keyword:** Free space optic; SAC-OCDMA; Optical amplifier; MD code.

## 1- Introduction:

Free Space Optic is a (LOS) communication where optical laser beam is used to transmit high data rate wirelessly through the atmospheric channel, the LOS leads to many advantages like improving the power efficiency and reduce multiple distortion [1]. Large atmospheric phenomena can affect on laser beam and cause degradation in FSO system. One of the most important phenomena that widely occurs in Iraqi cities and need to study how the system deals with it is Fog/Haze. This phenomenon widely occurs in Iraq because of influenced by dusty wind coming from western desert. Various techniques used to enhance FSO system like SCM-SAC-OCDMA, this technique is used by the researcher because of its several advantages like flexibility of channel allocation and privacy enhancement. Subcarrier multiplexing (SCM) is an attractive choice for high-speed optical data transmission and used today for transmitting multiple signals using single optical transmission; this will reduce the cost of the system [2], [3]. OCDMA allows multiple users to access the network asynchronously and simultaneously. SAC with multi-diagonal (MD) code has been used in system to permit more flexibility in the number of users in system and reject the overlapping that may occur between the user data when travelling through the atmospheric channel. An extra component added to the SAM-SAC-OCDMA system which is called "Optical Amplifier". The loss due to fiber attenuation necessitates a means to amplify the signal for communication over long distance, so the optical amplifier allows to compensate the loss of signal power [4]. In this modern new paper, we study the effect of fog/haze in Iraqi cities using SCM-SAC-OCDMA with intermediate stage (optical amplifier) to see the enhancement on the system by using 'opt systems' software Ver.7.

## 2. Description of the Proposed System:

Figure (1) shows the block diagram of the SCM-SAC-OCDMA with optical amplifier based on MD code. At the transmission side, user's data optically modulated using external modulator called "Mach-Zehnder" modulator after that send it to through free space channel. An intermediate stage called "Optical Amplifier" used as a mid point in system, the optical amplifier accept optical signal at many different wavelengths and then amplifies them many time according to the gain value that is ranging between (1-100) dB [5]. At the receiver side, type of photo-detector called An avalanche photo-detector (APD) used to detect the laser light and convert it to electric form and then pass it to types of filter (low pass filter-band pass filter) to reject the unwanted signal. BER used to realize the number of error bits occur in user data when travel through the medium.

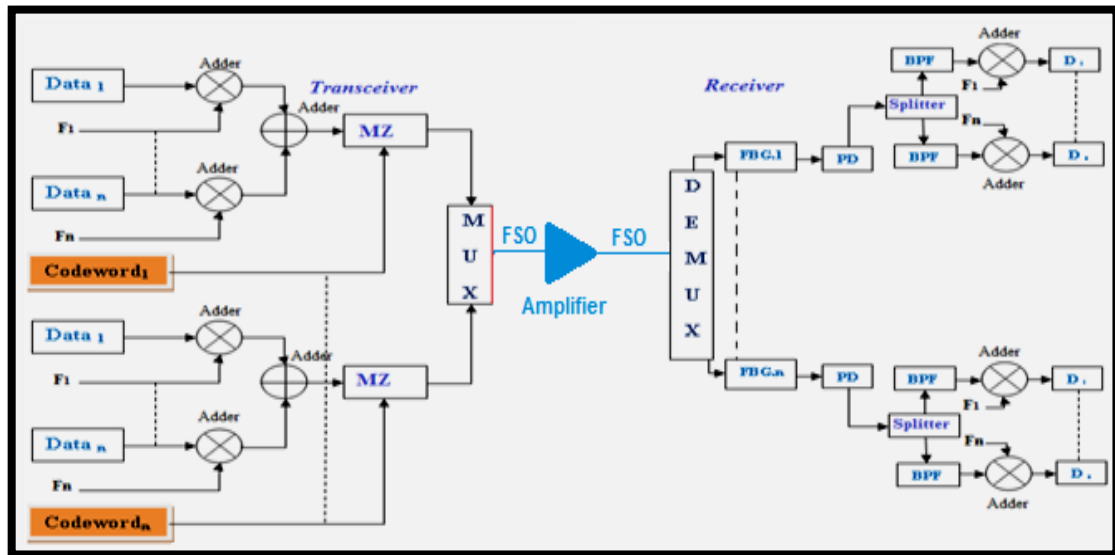

Fig. (1): system SCM-SAC-OCDMA with optical amplifier

## 3. FOG/HAZE Weather Attenuation:

Unfortunately, outdoor optical wireless link present additional challenge when compared to other indoor counterparts. Fog/Haze is phenomenon where dust , smoke and other dry particles obscure the clarity of the sky , it result in more particles to stay longer in atmosphere as compared to rain and hence present more serious degradation and affects the performance of wireless link and attenuates some or all the energy of the wave when traversing the atmospheric [6]. Fog/Haze turns the propagation environment into a multiple scattering medium and hence decreases the performance of laser beam [7]. A simple formula to calculate fog/haze attenuation using equation below [1]:

$$\alpha = \frac{3.91}{V} \left( \frac{W}{550} \right)^{-q} \quad (1)$$

Where q is size distribution coefficient of scattering, V is visibility in the transmission side, W is the wavelength used in the system.

According to Kruse model, q is given as [8]:

$$q = \begin{cases} 1.6 & v > 50 \\ 1.3 & 6 < v < 50 \\ 0.585 \times v^{\frac{1}{3}} & v < 6 \end{cases}$$

**Table (1) shows the visibility range in the three different regions of Iraqi cities**

Month	Jan	Feb.	Mar.	Apr.	May	June	Jul.	Aug.	Sept.	Oct.	Nov.	Dec.
V.in Baghdad(Km)	0.2	3	2	1.5	2.5	1	1.5	10	10	10	6	4
V.in Basra(Km)	0.8	4	2	4	3	1	4	10	10	4	2	0.2
V.in Mosul(Km)	0.2	6	3	6	3	1	4	10	6	2	3	1.5

#### 4. MD Matrex Design

The MD code is characterized by following parameters (N ,W, and  $\epsilon_c$ ) , where N is code length (number of total chips) , W is code weight (number of chips having value '1') ,  $\epsilon_c$  is in-phase cross correlation [9] .The matrix of MD code consist of  $\mathbf{K} \times \mathbf{N}$  matrix functionally depending upon the number of user that share the system ( $\mathbf{K}$ ) and code weight  $\mathbf{W}$ . Value of weight for MD code should be more than 1. MD code has zero cross correlation among the code words. Due to the zero cross correlations, there is no overlapping in spectral of different user and for this reason the effect of incoherent intensity noise has been ignored . The MD code for 5 users with  $W=2$  are given:

$$MD = \begin{pmatrix} 1000000001 \\ 0100000010 \\ 0010000100 \\ 0001001000 \\ 0000110000 \end{pmatrix}$$

So, the codeword for different users according to above example is :

$$Code\ word = \begin{cases} User1 \Rightarrow & \epsilon_1, \epsilon_{10} \\ User2 \Rightarrow & \epsilon_2, \epsilon_9 \\ User3 \Rightarrow & \epsilon_3, \epsilon_8 \\ User4 \Rightarrow & \epsilon_4, \epsilon_7 \\ User5 \Rightarrow & \epsilon_5, \epsilon_6 \end{cases}$$

MD code provides flexibility in choosing the value of number of user and the weight W. Moreover, there is no overlapping chips for different users since each user has its own spectral to transmit the data. Due to the reason of no overlapping, only one pair of detector is required comparing with other techniques .The MD code presents more flexibility in choosing ( W , K ) parameter and simply the design of the system project and thus lead to supply large number of user compared with other code like Modified Quadratic Congruence (MQC) and Random Diagonal (RD) codes. Furthermore, there are no overlapping chips for different users.

#### 5. Mathematical Model to Calculate Snr and Ber of the CM-SAC-OCDMA with Optical Amplifier

SCM-SAC-OCDMA system is effected by type of noise that showed be taken into account when determined signal to noise ratio (SNR). Thermal noise and Shot noise come from all possible electronics following the photo -detector [10].We have to take into account the effect of noise because the noise in laser has an important factor effect on signal performance in optical communication [11]. Thermal noise ( $I^{th}$ ), shot noise ( $I^{sh}$ ) and inter-modulation distortion ( $I^{IMD}$ ) noise happen in the photo detector due to the spontaneous emission of the uncontrolled photons emission .The SNR of an electrical signal is define as average signal power( $I^2$ ) to the average noise power( $\delta^2$ ) [12] :

$$\text{SNR} = \frac{I^2}{\delta^2} \quad (2)$$

Where

$$\delta^2 = I_{\text{th}}^2 + I_{\text{sh}}^2 + I_{\text{IMD}}^2 + \alpha_{\text{fog/haze}} \quad (3)$$

$$I^2 = \left[ \frac{R p_{sr} W}{N} u_{n,k} m_{n,k} \right]^2 \quad (4)$$

Where R is responsivity of photo-detector,  $P_{sr}$  is broadband power, N is MD code length,  $u_{n,k}$  is the normalized digital signal at the  $n^{\text{th}}$  subcarrier channel of the  $K^{\text{th}}$  codeword,  $m_{n,k}$  is the modulation index of the  $n^{\text{th}}$  subcarrier of the  $K^{\text{th}}$  users.

$$I_{\text{sh}}^2 = \frac{eBRp_{sr}W}{N} \quad (5)$$

Where e is electric charge, B is electric bandwidth.

$$I_{\text{th}}^2 = \frac{4k_b T_n B}{R_L} \quad (6)$$

Where  $k_b$  is boltzman constant,  $T_n$  is receiver noise temperature,  $R_L$  is receiver load resistor

$$I_{\text{IMD}}^2 = p_{sr}^2 R^2 m_{n,k} \left[ \frac{D_{1,1,1}}{32} + \frac{D_{2,1}}{64} \right] \quad (7)$$

$$D_{1,1,1} = \frac{N_s}{2} (N_c - N_s + 1) + \frac{1}{4} \{ (N_c - 3) 2^{-5} - \frac{1}{2} [1 - (-1)^{N_c}] (-1)^{N_c} + N_s \} \quad (8)$$

Where  $N_c$  is number of carrier,  $N_s$  is number of subcarrier.

$$D_{2,1} = \frac{1}{2} - 2 - \frac{1}{2} [1 - (-1)^{N_c}] (-1)^{N_s} \quad (9)$$

$$\text{SNR} = \frac{\left[ \frac{R p_{sr} W}{N} u_{n,k} m_{n,k} \right]^2}{\frac{eBRp_{sr}W}{N} + \frac{4k_b T_n B}{R_L} + p_{sr}^2 R^2 m_{n,k} \left[ \frac{D_{1,1,1}}{32} + \frac{D_{2,1}}{64} \right] + \frac{3.91}{V} \left( \frac{W}{550} \right)^{-q}} \quad (10)$$

The previous SNR equations show the average signal power to the average noise power that is generated in the photo detector. In this SCM-SAC-OCDMA system with the optical amplifier used, the noises that are generated due to the spontaneous emission of photon in optical amplifier must be taken into consideration.

The Amplifier Spontaneous Emission (ASE) noise is the main noise source of optical amplifier. The ASE effects on the accuracy of optical gain [13] and product by spontaneous emission photons travelling along the amplifier region [14].

The ASE noise of the optical amplifier is given by the following steps:

1- The spectral density of optical noise is Given by:

$$S_{sp} = (G - 1) f_{no} \frac{h\nu}{2} \quad (11)$$

Where **G** is the optical amplifier gain that used in the system,  $h\nu$  is the photon energy (constant value).

2- The optical amplifier noise figure  $f_{no}$  is related to the spontaneous emission factor  $n_{sp}$

$$f_{no} = 2n_{sp} \left( 1 - \frac{1}{G} \right) \cong 2n_{sp} \quad (12)$$

3- In the most of particle case, the noise figure value is between 3 and 7dB, the effective noise figure of the cascade of K amplifier with corresponding gains  $G_i$  and noise figure  $f_{no,i}$  can be expressed by:

$$f_{no} = f_{no,1} + \frac{f_{no,2}}{G_1} + \frac{f_{no,3}}{G_1 G_2} + \dots + \frac{f_{no,k}}{G_1 G_2 \dots G_{k-1}} \quad (13)$$

4-According to (11) (12) (13) equations, the total power of spontaneous emission noise for an optical amplifier followed by an optical bandwidth  $B_{op}$  is determined by [13], [12] :

$$p_{sp} = 2s_{sp(v)}B_{op} \tag{14}$$

$$p_{sp} = (G - 1)f_{no}h\nu B_{op} \tag{15}$$

The total SNR equation will be:

$$SNR = \frac{I^2 + \text{Optical power o.p.}}{I^2_{th} + I^2_{sh} + I^2_{IMD} + \alpha_{fog/haze} + p_{sp}} \tag{16}$$

$$SNR = \frac{\left[ \frac{RP_{sr}W}{N} u_{n,k} m_{n,k} \right]^2 + \text{Optical power o.p.}}{\frac{eBRp_{sr}w}{N} + \frac{4k_bT_nB}{Rl} + p^2_{sr}R^2m_{n,k} \left[ \frac{D_{1,1,1}}{32} + \frac{D_{2,1}}{64} \right] + \frac{3.91}{V} \left( \frac{W}{550} \right)^{-q} + (G-1)f_{no}h\nu b_{op}} \tag{17}$$

Using Gaussian approximation equation, the Bit Error Rate can be expressed as:

$$BER = \frac{1}{2} \operatorname{erfc} \sqrt{\frac{SNR}{8}} \tag{18} \quad \operatorname{erfc} \text{ defines as error function.}$$

Parameter used to numeric calculates the SNR and BER are obtained in table (2).

**Table (2): parameter used in numeric calculation**

Symbol	Values	Units
$p_{sr}$	5	dB
$V$	Table (1)	Km
$B$	311	Mhz
$T_n$	300	K
$e$	$1.6 \times 10^{-19}$	c
$h$	$6.66 \times 10^{-34}$	Js
$k_b$	$1.38 \times 10^{-23}$	J/K
$N_c$	3-10	-
$N_s$	2-20	-
$G$	30	dB
$f_{no}$	1.9	dB
$h\nu$	$1.28 \times 10^{-19}$	-
$B_{op}$	20	GHz
$R$	$1.32 \times 10^{13}$	-
$q$	Kruse model	-
<b>Optical power o/p</b>	$4.55 \times 10^{-3}$	W
$W$	1550	nm

## 6. Data Analysis and Result:

Figure (2) shows the proposed SCM-SACOCDMA system with gain stage "optical amplifier " which is built using "opt system" software. Data was received from Iraq meteorological department of year 2016 for the three different regions [Baghdad, Basra and Mosul].

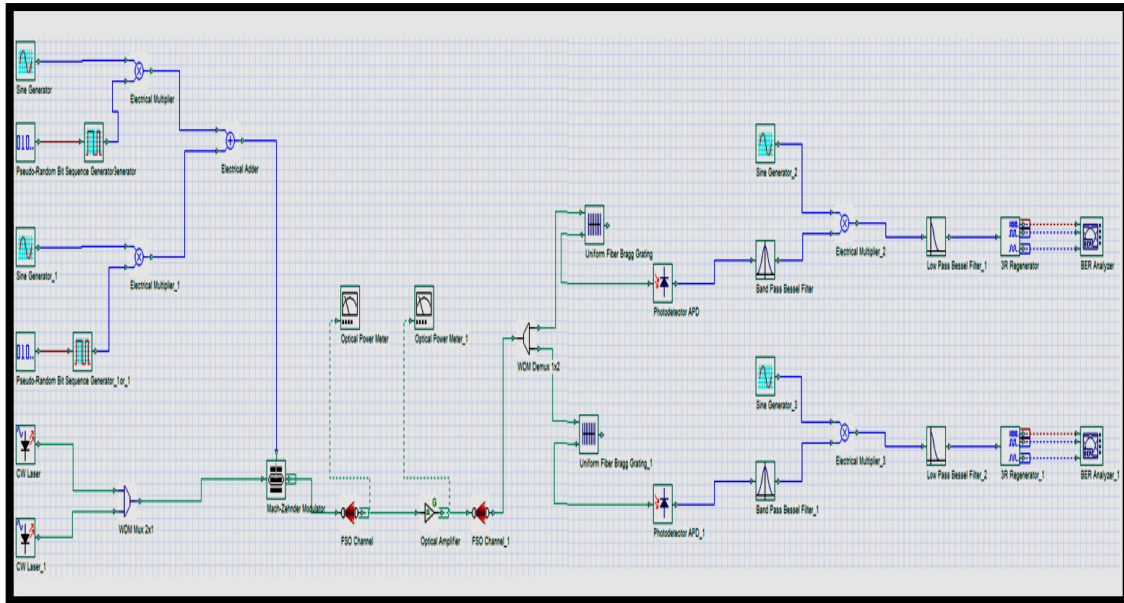

**Fig. (2): SCM-SAC-OCDMA system with optical amplifier technique**

fog/ haze especially haze widely occur in Iraq region because of its geographical nature, figure (3) shows monthly fog/haze attenuation value effect on the signal performance which lead to decrease its parameter and increase number of bit error rate (BER) in the receiving sides .

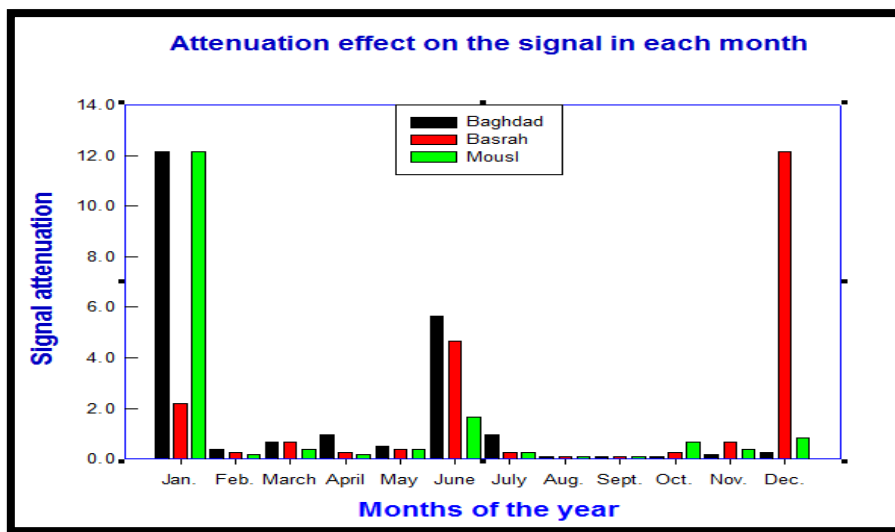

**Fig. (3) Attenuations of fog/haze in each month**

The eye diagram which is image look like the opening of an eye that shows the quality of signal that suffer impairment as it travels from its point to its final distention, it can be seen that pure eye mean the signal travel in smooth path with less signal attenuations, the visibility less than 200m lead to increase BER and eye diagram seem to be in unregulated shape, visibility higher than 10Km mean less particles dust in the air. Figure (4) shows the eye diagram of three rang of visibility in Iraq [minimum visibility ( $> 200m$ ), mid visibility ( $1km < v < 9km$ ), high visibility ( $> 10km$ )].

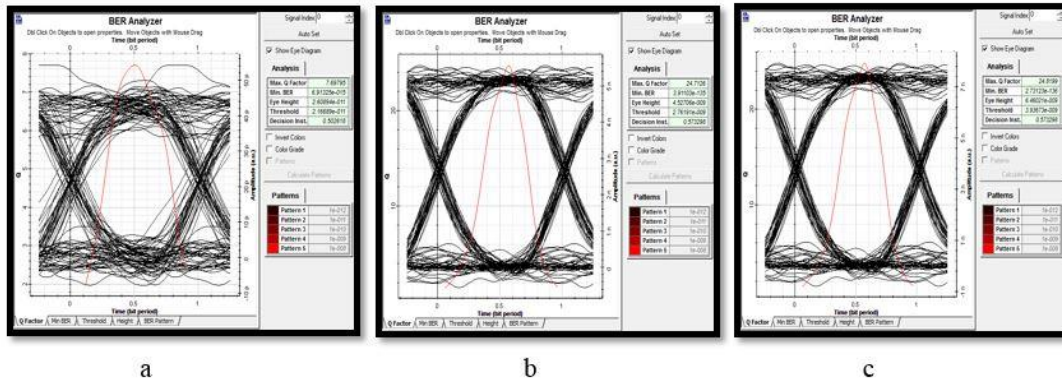

**Fig. (4):** the eye diagram and BER of the three different regions (a. minimum visibility, .b. mid visibility,c. high visibility)

Fig. (5) Shows that the visibility can effect on the laser beam and prevent it to transmit in regular path. Fog/haze decreases the visibility because particles of dust stay long time unlike rain weather.

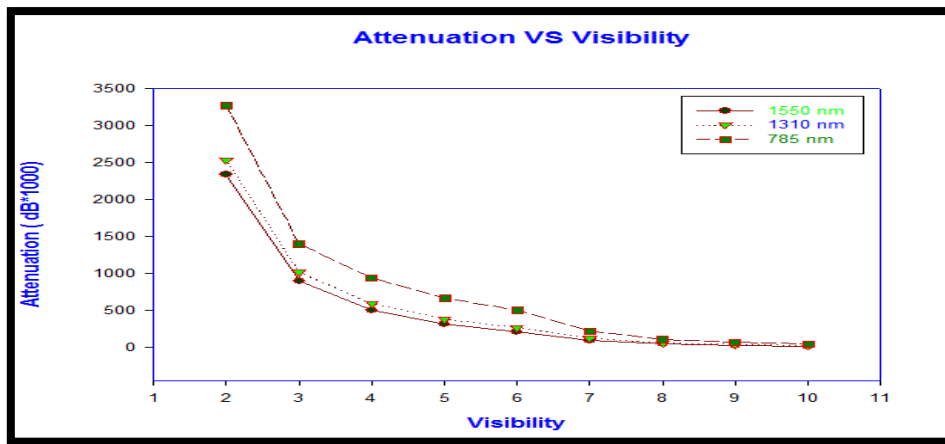

**Fig. (5):** signal attenuations against visibility factor

Fig.(6) shows the enhancement that the optical amplifier gives to the system, it is clear that the amplifier compensate the power loss that occur in signal transmission when atmospheric phenomenon effect on laser beam , the optical amplifier increases the SAR which lead to decrease BER and enhances SCM-SAC-OCDMA system .

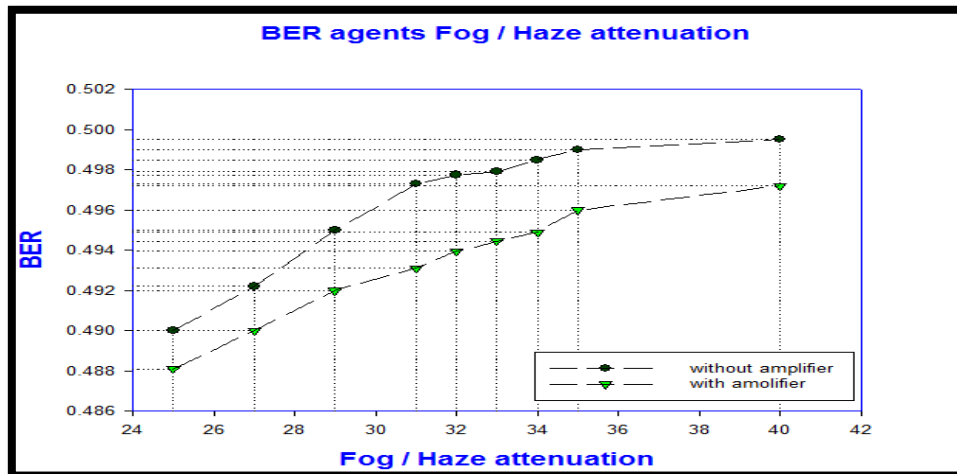

**Fig. (6):** BER against fog/haze attenuations

## 7. Conculusion

This paper analyzed in details the effect of different haze condition on the SCM-SAC-OCDMA system free- space optical communication application. The analyzed based on Multi-Diagonal (MD) code, which is considering the recent code in OCDMA by providing zero-cross correlation probability. Optical amplifier used in the system to permit the information signal to travel in long distance with high power. Based on the proposed system, signal can cut 1.85Km as a transmission distance with 1Gbps as transmission data. BER for heavy haze condition ( $v=0.2\text{km}$ ) is  $10^{-12}$  and in mid and light haze is between ( $10^{-135}$  to  $10^{-136}$ ).

### CONFLICT OF INTERESTS.

There are no conflicts of interest.

## 8. References

- [1] Subrat kar, v.k.jain, Hemani kaushal, "free space optical comunication", published by springer science, p.p.6-15, 2017
- [2] kirk p.Arnett, kyo-il chung, xiaofeng song, Hojjat Adeli,"High speed optical coherent transmission system using narrowband FM subcarrier multiplexing, " proceeding of future generation information technology, Springer science, 8<sup>th</sup> October, p.p 100-107, 2011 .
- [3] James Downing, "fiber optic communication", Cengage Learning, p.p.88-89, 2004.
- [4] Enrico forestieri, " Optical Communication: Theory and Techniques ", Springer science & business media, p.p.104-106, 2006.
- [5] Gosse wedzinga, "Photonic Slot Routing in Optical Transport", Springer science & business media, p.p.22-23, v.4, 2003.
- [6] Ziran sun, sevia M.Idrus,Roberto Ramirez-inigusz," Optical Wireless Communication : IR for Wireless Connectivity ", CRC press,p.p.25-29,2008 .
- [7] George karagiannidis, john barry, shlomi arnon, "Multiple technique for indoor optical wireless", proceeding of advanced optical wireless communication system, Cambridge university college,24<sup>th</sup> May, p.p 91-116, 2012.
- [8] Tony antony, A shwin Gumaste,"First Mile Access Network And Enabling Technologies", ch.6, cisco press, p.p.153, 2004
- [9] Gurpreet.K , Gurinder.S , " Performance analysis of SCM-OCDMA in free space optical medium using MD and DDW code" ,"proceeding of 2015 RA ECS UIET paniab university Chandigarh 21-22<sup>nd</sup> ,p.p 978-980, 2015 .
- [10] Arun K.Majumdar,"Advanced free Space Optics (FSO) ", Springer science, p.p.279, 2014.
- [11] Mitsuo Fukuda, "Optical semiconductor device", John Welij&Sons, p.p 190 -184 -189, 1999
- [12] HUSSAIN.S.M, RASHED.Ali.F, THANAA, generation of new hybrid subcarrier multiplexing SAC-OCDMA system based on FSO, IEEE journal, theoretical and applied information technology, p.p389-396, 2013
- [13] Rongqin Hui, M.O'sullivan, fiber optic measurement technique, Elsevier science, p.p 325-327, 2009
- [14] ALI.R , HAMED.B , REZA.M , " Nanostructure Semiconductor Optical Amplifier" ,published by springer – verlag, Berlin, Heidelberg , p.p.16 , 2011
- [15] MILORAD.C, "Optical Transmission System Engineering", ARTECH HOUSE, p.p.173-174, 2004.



راشد علي فياض

هاشم عبد الرزاق جبار

الجامعة الفرات الاوسط، كلية تقنية للهندسة الكهربائية

r\_rashid47@yahoo.com

hashem.jabar@yahoo.com

### الخلاصة:

بصريات الفضاء الحرة (FSO) هو نظام اتصالات حديث وجديد حيث الفضاء الحر بمثابة وسيلة بين المرسل والمستلم، وينبغي أن تكون في خط البصر (LOS) لنجاح نقل شعاع الضوء. ونظرا لمتوسط المساحة الحرة، فإنها تعاني من تداخلات مختلفة مثل [المطر والضباب والتلج] التي يمكن أن تؤثر على أداء الإشارة وتؤدي إلى تقليل توافر الإشارة، الموثوقية وصلة الاتصال. وبسبب المناخ الصحراوي العراقي، فإنه يتعرض للعواصف الترابية في معظم الوقت من السنة أكثر من مناطق أخرى، لذلك فمن المهم لدراسة تأثير الجو الترابي وإيجاد طريقة مناسبة للحد من هذا التأثير الجوي على شعاع الليزر عند السفر إلى النقطة النهائية للإشارة. ترميز الطيف الضوئي \_ الشفرة الضوئية المتعددة المنافذ (SAC-OCDMA) أصبح مجالاً رئيسياً للبحوث في نظام الاتصالات البصرية. OCDMA تسمح للمستخدم المتعدد للوصول إلى النظام دون أي خلاف، ترميز متعدد الاقطار (MD) يستخدم في النظام لدعم عدد كبير من المستخدمين مع ارتفاع معدل البيانات المرسل. مكبر للموجة البصرية يضاف إلى النظام لتوفير المزيد من التحسين والسماح لإرسال شعاع الليزر لمسافات طويلة وانخفاض التدخل بين الموجات المرسل. وتبين نتيجة الدراسة أن أداء النظام المقترح أفضل من النظام بدون مكبر للموجة البصرية. ويمكن ملاحظة أن معدل الخطأ في البتات (BER) في الحد الأدنى من الرؤية ( عند وجود عاصفة ترابية ) يصل إلى  $8 * 10^{-12}$  ، معدل الخطأ في البتات في الرؤية المتوسطة بين  $(1 * 10^{-137} & 8 * 10^{-138})$  ، معدل الخطأ في البتات مع الوضوح العالية  $(1 * 10^{-138})$  مع 1.85 كم كمسافة انتقال البيانات و 1 جيجا بايت كبيانات نقل للمستخدم.

**كلمات الدالة:** - بصريات الفضاء الحرة; مكبر للموجة البصرية; الترميز متعدد الاقطار; ترميز الطيف الضوئي- الشفرة الضوئية المتعددة المنافذ.