

Effect of Current Transformer Impedance on Secondary Injection Accuracy

Ameer Aqeel Mohammed

*Computer System Department, Babylon Technical Institute, Al-Furat Al-Awsat
Technical University, 51015 Babylon, Iraq*

Eng_ameer2012@yahoo.com

Zaid Tariq Hasan

Electrical Engineering Department, University of Kufa

zaidt.alhaddrawi@uokufa.edu.iq

Ghasan Ali Hussain

Electrical Engineering Department, University of Kufa

ghasan.alabaichy@uokufa.edu.iq

Abstract:-

The traditional procedure of the secondary injection test includes splitting the secondary winding of current transformer from the test circuit. This work investigates whether the presence of the current transformer secondary winding inside the test circuit affects the accuracy of the test results or not. Matlab/Simulink has been used in this paper for modeling and simulating the tested circuit. Paper results show that the accuracy of the test is not affected when the secondary winding of current transformer presence inside the test circuit.

Keywords: Secondary injection; Current transformer; CT tests.

الخلاصة

ان الطريقة التقليدية لاجراء اختبار الحقن الثانوي تتضمن فصل الملف الثانوي لمحولة التيار عن دائرة الفحص. هذا البحث يتحقق من ان وجود الملفات الثانوية لمحولة التيار ضمن دائرة الفحص يؤثر على دقة نتائج الفحص لم لا. تم استخدام برنامج الماتلاب من اجل نمذجة و محاكاة دائرة الفحص. لقد اظهرت نتائج الاختبارات بان وجود الملف الثانوي لمحولة التيار ضمن دائرة الحقن الثانوي لا يؤثر على دقة نتائج الفحص.

الكلمات المفتاحية: الحقن الثانوي; محولة التيار; اختبارات محولة التيار .

Introduction

Protection relays and measuring equipment's are an important part of power system, without them, the power system can't operate (Zeineldin *et.al.*, 2015). During routine maintenance of the protection system, comprehensive tests are conducted. One of the most significant tests is Secondary Injection (S.I.) test, which verify the protection system operation and the current transformer (CT) secondary circuit continuity.

In practical, CT consists of two or more cores, one for metering and the other for protection. Each core has different specification depends on its usage, where the protection relays (which are connected to the protection core of the CT) are responsible of detecting the fault condition depending on its characteristics, so that the accuracy of their test is very important issue (Kinan *et.al.*, 2016).

This paper is intended to examine the effect of secondary winding of current transformer on the accuracy of the S.I. test and then decided whether it must be disconnected or not from the S.I. test circuit. As the S.I. test involves injection current in the secondary circuit of the CT in order to check the relay performance in comparing with the relay characteristic. The CT winding is a part of secondary circuit, which make it included in the test loop. For this reason, it may constitute another path for current, leading to the test accuracy error. So that, it is so interested to determine the degree of this impact for different test conditions in order to obtain a final conclusion, that the CT secondary winding must be disconnected from the circuit or not during the test.

Current Transformer:-

The main aim of CT is to supply the protection and measuring devices in the substation with a secondary small current. A simple representation of the CT circuit connection is shown in **Figure(1)**, where I_p and I_s represented a primary and secondary current, N_p and N_s are a primary and secondary turns number, R_{CT} is the CT wires equivalent resistance and Z_B is the burden impedance.

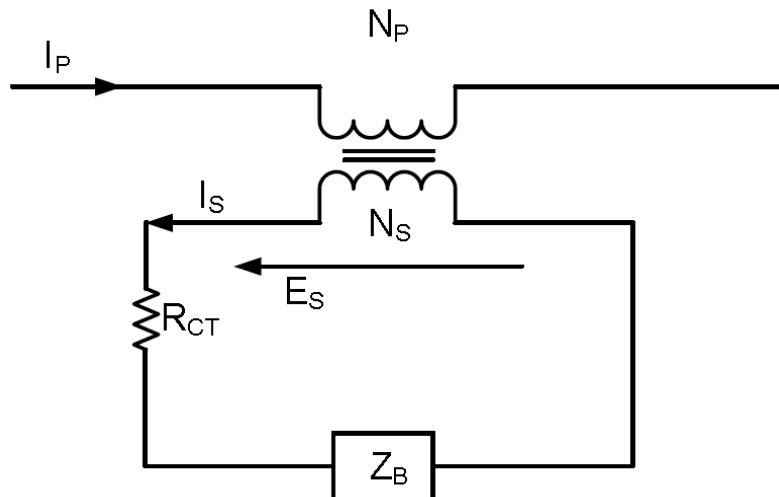

Figure (1) Current Transformer Connection

Secondary current value is proportion with the current which flow in the primary circuit. The rated current for the secondary side is always 1 or 5 Amperes with different rated value for primary current such as (300:5, 1200:5, 2000:1). These ratings indicate the continues operating current of the CT which approximately match the system normal operation current (Zeineldin *et.al.*, 2015). The primary side of the CT is in series with the power system conductor, which makes the power transformer relationship applicable for the CT:

$$N_s / N_p = I_p / I_s \quad (1)$$

The equivalent circuit of CT is shown in **Figure(2)** (Rafajdus *et.al.*, 2010), where R_1 , R_2 , L_1 and L_2 represent the primary and secondary side resistance and inductance respectively. In real conditions, R_b is resistance of the burden. The magnetizing branch is represented by a non-linear magnetizing inductance L_μ , which is a function of magnetizing current I_μ . As appears from the equivalent circuit; it is not

all of the secondary current passed through the current sensing device, but some of it goes into the magnetizing branch cause CT error (Duncan *et.al.*, 2008).

The burden of the CT is very important point which should be considered in the design and operation of the CT, it includes the impedance of wires in addition to the impedance of the connected device in the secondary side. The burdens of CT rating are expressed by VA, example of CT 300:5, 50VA and 200:5, 60 VA (Jae KapJung *et.al.*, 2007).

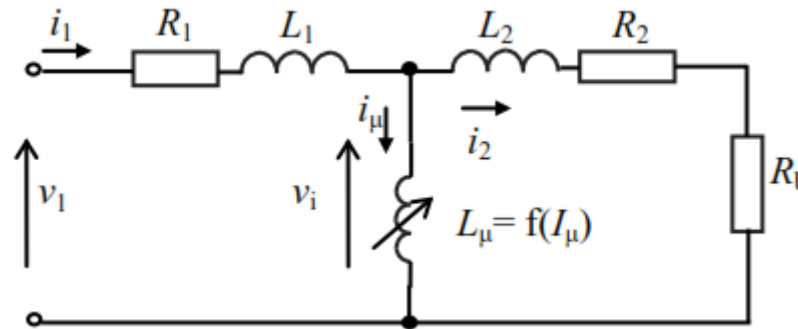

Figure(2) Equivalent Circuit of CT

Secondary Injection Test:-

The S.I. test is carried out to check the operation of the protection relays i.e. overcurrent, distance, breaker failure relays...etc. with respect to any elements which are connected to the secondary of the CT. In addition to the tripping performance of relays, the S.I. test also checks all the circuits and equipment included in the secondary side of the CT (Davies *et.al.*, 1996).

The S.I tests simulate the CT secondary current by injection 1 or 3 phase currents to emulate the normal and fault condition.

Figure(3) shows S.I. test for checking the relay performance, where $P1$, $P2$ are the primary connection points of the CT and $S1$, $S2$ are the secondary connection points. The usual procedure for the S.I. test is shown in the Figure(3), including the disconnection of the primary circuit and isolating the tested device “relay” from the CT secondary side.

The main aim of this study is to discuss the procedure of the S.I. test and to check the test accuracy. It is affected, in case, that the test whether performed with the relay is not disconnected from the CT secondary side.

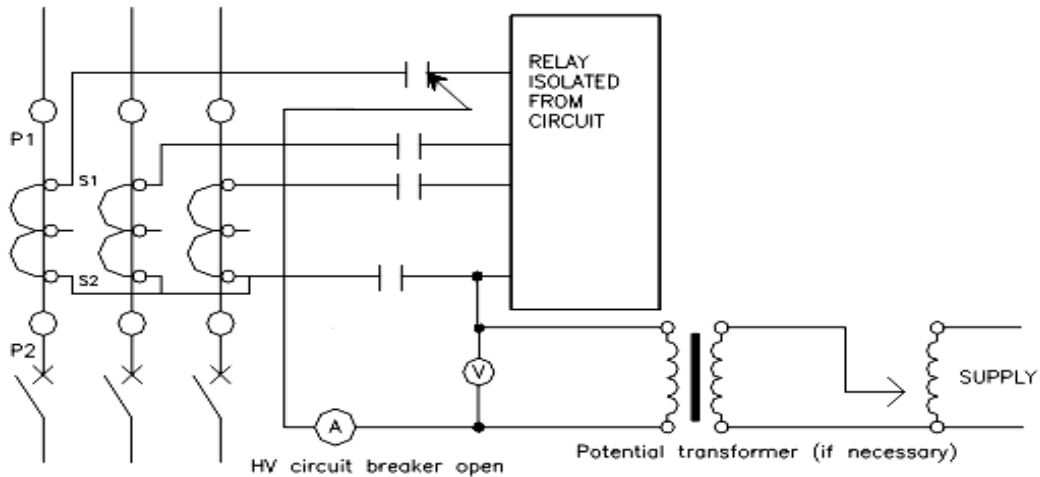

Figure (3) Secondary Injection Tests

Simulation Results:-

In order to check the accuracy of the S.I. test, the work implies execution of the S.I. test for several times with different levels of the injected secondary current and burdens, for two cases with and without CT secondary winding in the S.I. test loop.

The simulation is performed by using Matlab/ Simulink. The following models have been employed in this work:

A. CT model

This model is represented by using linear transformer model from Simulink library(which has been used in Matlab examples as a current transformer, after modifying its input parameters). **Table (1)** shows the parameters of CT models for two different ratios that are required for the simulation. Due to the low number of turns in both sides of CT " one turn in the primary side", the value of inductance can be equal to zero "**neglected**".

Some of values appear in per unit quantity which have been calculated using the base value of $V(base)=Vl$ and $P(base)=rated\ burden(Pn)$.

$$R (Pu) = R(\Omega) / R (base) \quad (2)$$

$$L (Pu) = L(H) / L (base) \quad (3)$$

$$R (base) = X (base) = (Vn)^2 / (Pn) \quad (4)$$

$$L (base) = X (base) / 2\pi f \quad (5)$$

TABLE (1) Current transformer parameters

CT ratio	Burden (VA)	V1 (V)	R1(pu)	L1(H)	V2(V)	R2(Ω)	L2(H)	Rm(pu)	Lm(pu)
1200:5	100	20/240	0.35	0	20	1.389	0	50	50
2000:5	200	40/400	0.35	0	40	1.444	0	50	50

B. CT burden model

The burden of the current transformer includes the CT secondary wire impedance in addition to the connected device impedance. Because of the low inductance value "**neglected value**" in the two previously mentioned impedances. In this paper, the burden is represented by a single pure resistance $Z=R$.

For the calculation of the burden resistance value, CT parameters can be used for that purpose. For example, the CT of the following parameters 1200:5, 100 VA, if its operated in the rated burden, the burden's resistance can be calculated as following:

$$R = P / I^2 \tag{6}$$

Then in this example the burden's resistance $R = 4$

C. Secondary injection device model

The S.I. device is represented by a 50Hz single phase AC voltage source; its voltage level can be changed to simulate different current injection.

The simulation test's strategy includes executing the S.I. test according to the **Table (2)**. The S.I. test have been repeated 12 times, 6 times for CT included in the S.I. test loop and the others without CT. The injected current starts from the CT rated secondary current to 4 times of it.

TABLE (2) Test strategy

CT ratio	Burden (VA)		Injection current (A)
	<i>Rated</i>	<i>Tested</i>	
1200:5	100	50	5 10 20
		100	5 10 20
	200	100	5 10 20
		200	5 10 20

For the first test, when CT secondary winding is disconnected from the S.I. test loop as shown in **Figure(4)**, the results show that the entire S.I. device's output current goes through the tested load.

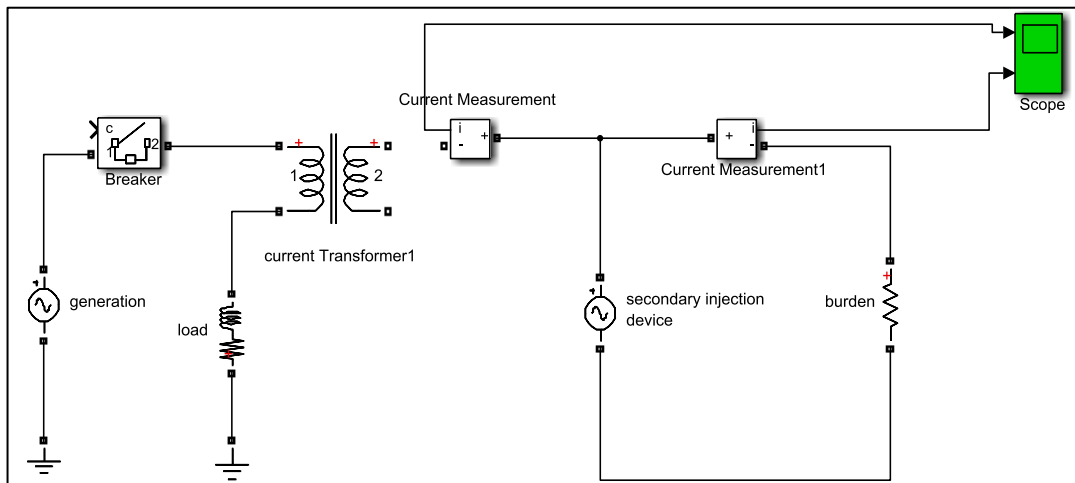
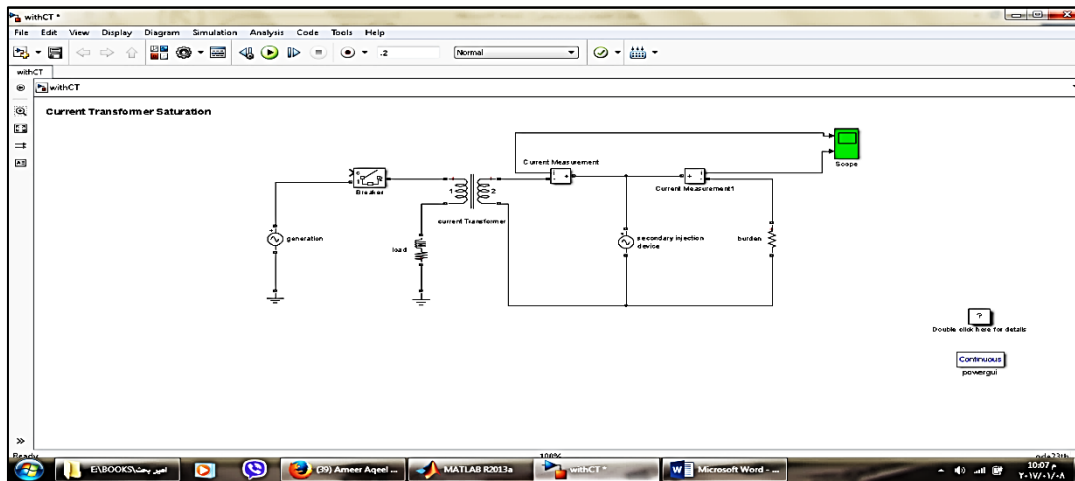

Figure (4) CT Disconnected from the S.I. test loop



Figure(5) CT Connected with the S.I. test loop

In the second test when CT secondary winding connected to S.I. test loop as shown in **Figure(5)**, a negligible part of the injected current passed through the CT winding side, **Figures (6, 7 and 8)** show the value of this current for different CT ratings, burdens and levels of the injected current.

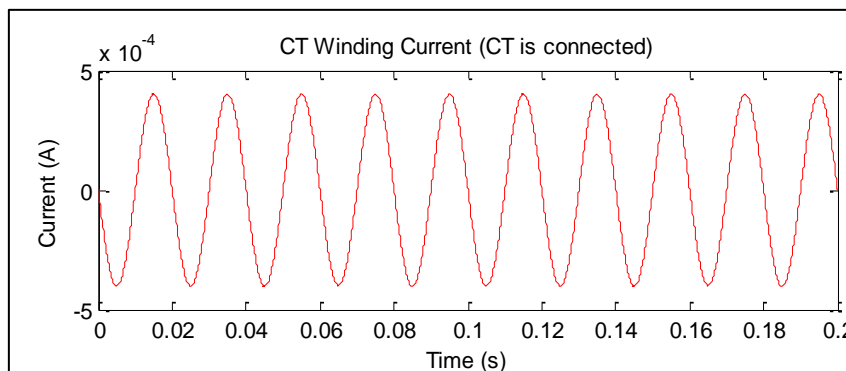

Figure (6) CT Winding Current, CT 1200:5, 100VA, 4Ω, injected 5A

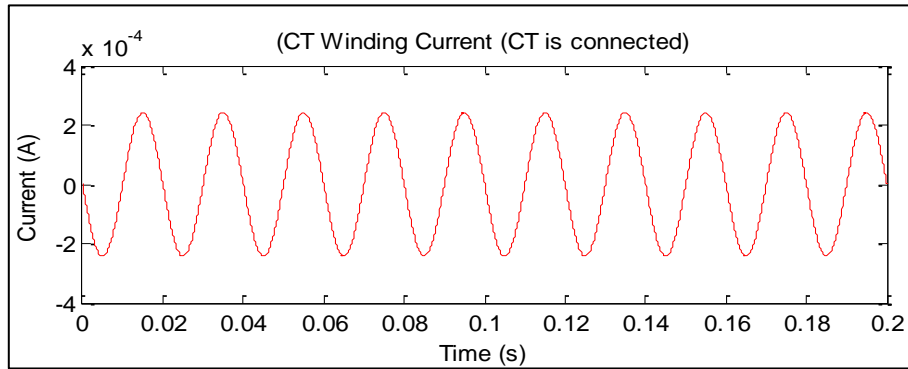

Figure (7) CT Winding Current, CT 1200:5, 50VA, 2Ω, injected 10A

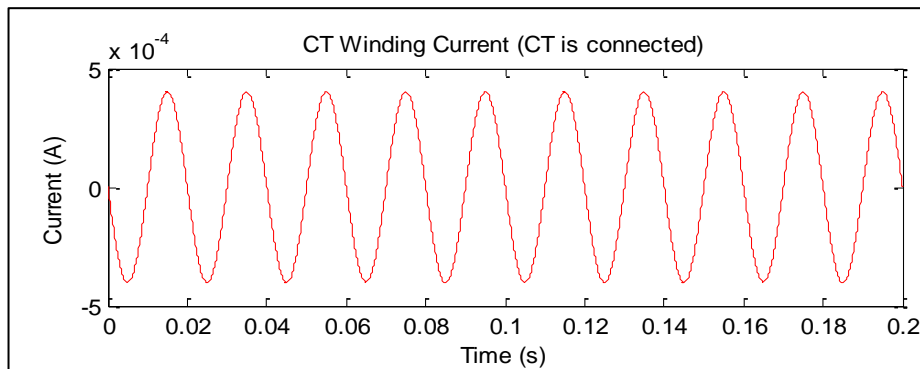

Figure (8) CT Winding Current, CT 2000:5, 100VA, 4Ω, injected 20A

To explain the extent of the effect of the CT windings, **Figures (9, 10 and 11)** show a comparison between burden's current with and without CT winding, for some cases of **Table(2)**.

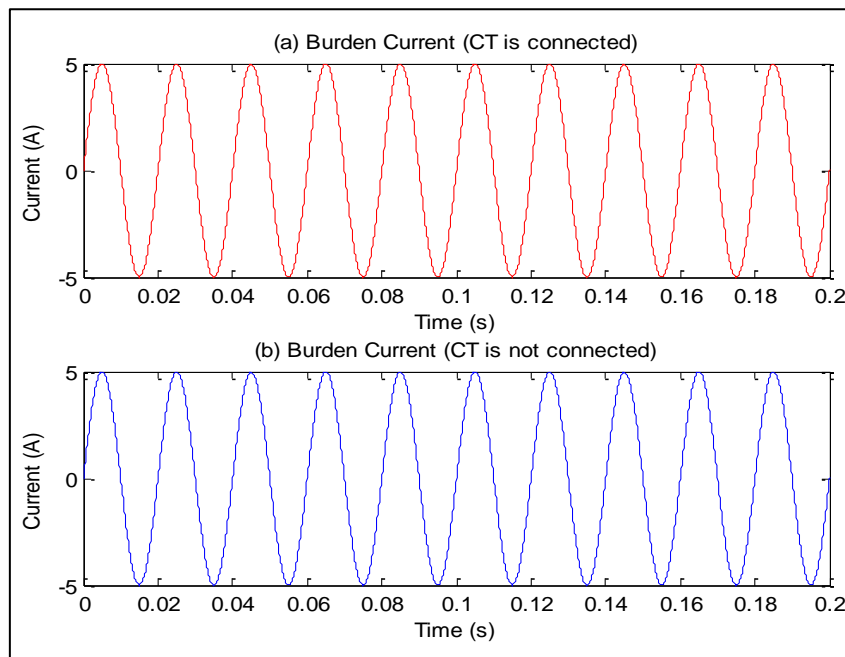

Figure (9) Burden Current, CT 1200:5, 100VA, 4Ω, injected 5A

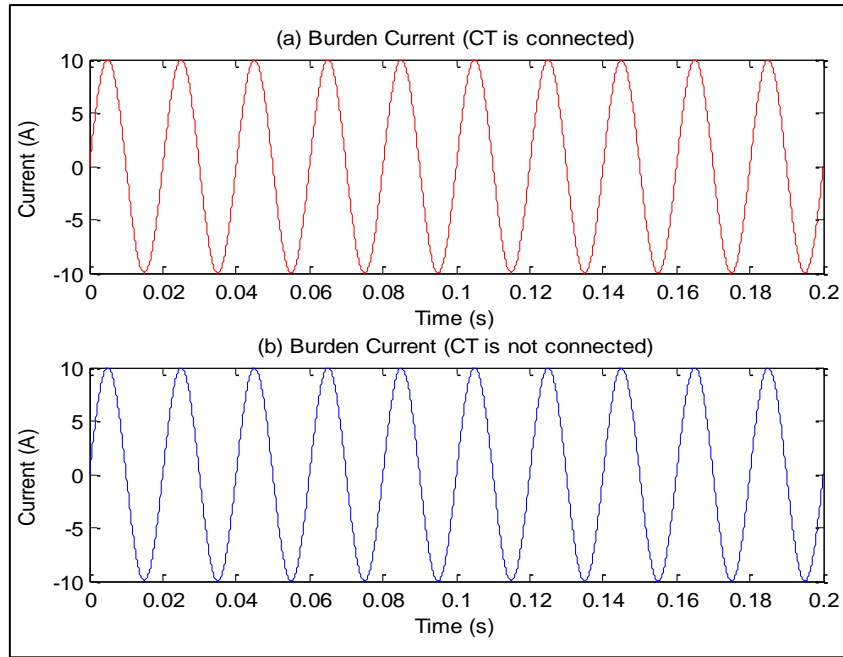

Figure (10) Burden Current, CT 1200:5, 100VA, 4Ω, injected 10A

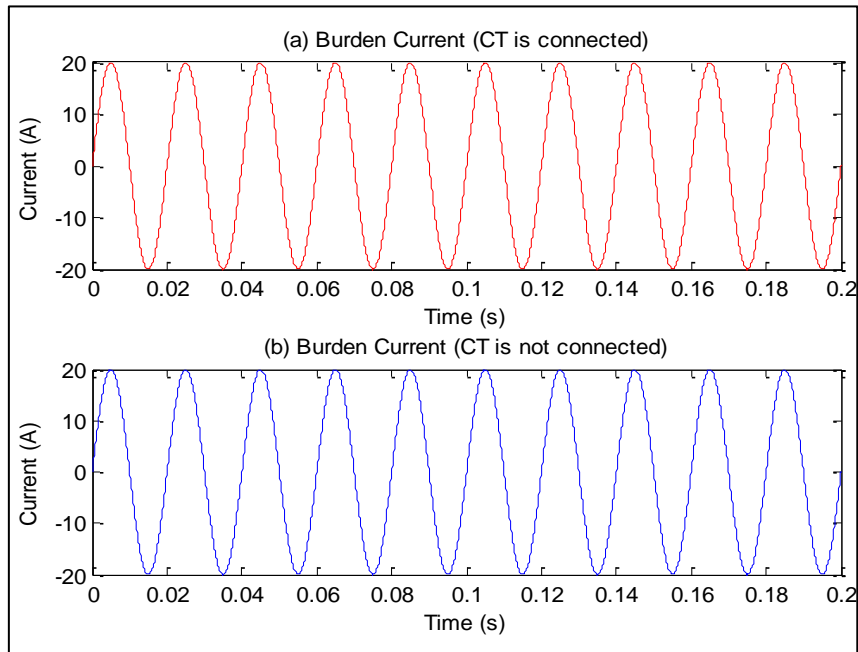

Figure (11) Burden Current, CT 2000:5, 100VA, 4Ω, injected 20A

As shown in the previous figures; there is no clear different between burden current in the two cases. So that the existence of the CT winding in the S.I. test loop accuracy doesn't affected since there is approximately no current pass through the CT side as explained above.

Conclusion:-

This work has explained the S.I. test, which is one of the important and repeated tests for maintenance and contingency purposes. The results that have been gained with Matlab/Simulink, show that when the S.I. test is executed without disconnecting

the CT secondary from test loop as shown in **Figure (5)**, the accuracy of the test is not affected. As a final conclusion, the S.I. test can be performed without disconnecting the relay from the secondary circuit of the CT, which leads to:

- Reducing the test processes.
- More saving in time.
- Preventing the mistakes that may happen due to disconnection and reconnection of the CT (i.e. CT open circuit).

References

- Davies T. , 1996, "Protection of Industrial Power Systems," Elsevier Ltd, Great Britain,second edition.
- Duncan Glover J., Mulukutla S. Sarma and Thomas J. Overbye, 2008, "POWER SYSTEM ANALYSIS AND DESIGN," Cengage Learning,fifth edition,US.
- Jae KapJung, HongKang, Sang HwaLee andMyungsooKim, November–December 2007, "In-situ measurement of the current transformer burden in a current transformer testing system using a shunt resistor," vol. 40, Issues 9–10, pp 876-882.
- Kinan Wannousand, Petr Toman, 2016, "The Impact Of Current Transformer Saturation On The Distance Protection," Electric Power Engineering (EPE), 17th International Scientific Conference.
- Rafajdus P, Bracinik P, Hrabovcova V. ,2010 Jan ,The current transformer parameters investigation and simulations. Elektronika ir Elektrotechnika. 1;100(4):39-2.
- Zeineldin H. H., Hebatallah M. Sharaf,Doaa K. Ibrahim and Essam El-Din Abou El-Zahab, January 2015, "Optimal Protection Coordination for Meshed Distribution Systems With DG Using Dual Setting Directional Over- Current Relays," IEEE transactions on smart grid, vol. 6, NO. 1.