

JES-Physical Sciences

# Design of Ripple Free Single Phase Isolated Converter using DC Active Filter with Centre Tap Transformer

A. Sandhiya, A. Peer Fathima, P. Balamurugan\*

Department of Electrical Engineering, SRM Easwari Engineering College, Ramapuram, Chennai, Tamilnadu, India

Article Info	Abstract
<p><b>Article History</b></p> <p>Received : 13-01-2011            Revised : 16-05-2011            Accepted : 17-05-2011</p> <p><b>*Corresponding Author</b></p> <p>Tel : +91-4443923027            Fax : +91-4422490430</p> <p>Email:            sandhiece@gmail.com            fniraj@yahoo.co.in            murugan.04@gmail.com</p> <p>©ScholarJournals, SSR</p>	<p>A ripple current reduction method is proposed that does not require additional switching devices. A current ripple that has twice the supply frequency of the power supply is generated in the dc part when a single-phase pulse width modulated inverter is used for a grid connection. The current ripple causes shortening of the lifetime of electrolytic capacitors, batteries, and fuel cells. The proposed circuit realizes a dc active filter function without increasing the number of switching devices, because the energy buffer capacitor is connected to the center tap of the isolation transformer. In addition, the buffer capacitor voltage is controlled by the common-mode voltage of the inverter. The features of the proposed circuit are described and Simulation results are presented. Simulation results proves the ripple reduction, to approximately 20% that of the conventional circuit.</p> <p><b>Key Words:</b> Center tap, DC active filter, Grid connection system, Ripple current reduction, Single-phase isolated converter</p>

## Introduction

Recently, energy sources such as wind power system, photovoltaic cells, and fuel cells have been extensively studied in response to global warming and environmental issues. A grid interconnection converter using an isolation transformer is preferable for power grid distribution systems in terms of surge protection and noise reduction. In addition, size reduction and high efficiency are essential requirements.

One of the problems in the fuel cell system is that lifetime is decreased by the ripple current. Therefore, in order to extend the lifetime, the fuel cell ripple current must be reduced in the grid interconnection converter[4]. However, when a single-phase pulsewidth-modulated (PWM) inverter is used for grid connection system, the power ripple is twice the frequency of the power grid[3]. Therefore, in conventional grid connection inverters, large electrolytic capacitors are connected in parallel to the fuel cell in order to reduce the current ripple. However, the use of large-sized electrolytic capacitors increases both the device volume and cost. In order to reduce the current ripple in the fuel cell, some approaches use high-speed current control. This method incorporates a current-loop control within the existing DC-DC converter voltage loop. However, a large capacitor or reactor is required as an energy buffer.

Other approaches have been proposed that do not require the use of large-sized electrolytic capacitors, an active filter is applied in the dc-link part. The dc active filter consists of a small capacitor as an energy buffer, a reactor to reduce the switching ripple, and a dc chopper[3]. The dc chopper injects the ripple current to avoid a power ripple capacitance can be lower, because the terminal voltage of the capacitor can be varied over a wide range. However, the number of the switching devices is increased, requiring a high-cost dc

chopper and resulting in a large volume device. Other configurations of DC active filters have similar problems.

This paper proposes a new circuit topology including a dc active filter function without extra switching devices. The proposed circuit consists of an isolated DC/DC converter and interconnection inverter, and achieves the dc active filter function using the center tap of the isolation transformer[5]. One feature of the proposed converter is that the primary-side inverter in the DC/DC converter is individually controlled by the common-mode voltage and the differential voltage. The ripple current is suppressed by the common-mode voltage control of the DC/DC converter, and the main power flow is controlled by the differential mode voltage.

Conventional and proposed circuit topologies with the principle of current ripple suppression are first introduced. The control method of the proposed circuit is then described. In addition, the design of the energy buffer capacitor and transformer by which the maximum power ripple can be accepted is indicated. Furthermore, simulation results are presented in order to confirm the validity of the proposed circuit.

## Proposed Circuit Configuration

Fig. 1 shows the proposed circuit, which combines the first stage inverter and DC active filter functions. The energy buffer capacitor  $C_r$  is connected to the center tap of a medium-frequency transformer. The zero vector of the full-bridge first stage inverter is used to control the center tap potential voltage. In addition, the leakage inductance of the transformer is used to suppress the switching current in

addition to the boost reactor  $L_r$ . If the leakage inductance is large enough, then the boost reactor is not required.

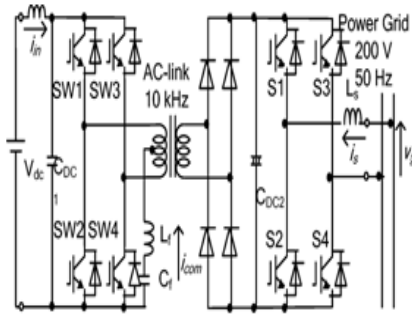

Fig. 1. Proposed circuit.

**Switching Pattern Generation**

Fig. 2. illustrates the two switching modes of the first-stage inverter in the proposed circuit. In the differential mode, the terminal voltage of the transformer is controlled, as shown in Fig 2 In the common mode, the center tap voltage is controlled, as shown in Fig. 3. When the differential mode is selected, the power transfers to the secondary side When the capacitor voltage is greater than half of the DC voltage, the buffer capacitor is charged.

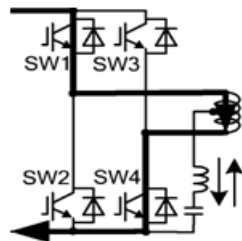

Fig 2. Differential mode

When the capacitor voltage is less than half of the dc voltage, the buffer capacitor is discharged. The inverter outputs the zero voltage vectors (00 and 11 are two) in common-mode operation. When the zero voltage vectors are selected, the line- to-line voltage of the transformer is zero. However, the center tap voltage is either VDC or zero, depending on the zero vectors.

Thus, by controlling the ratio of the zero vectors, the buffer capacitor can be charged or discharged. The differential-mode current increases when the common-mode voltage increases, because the power transmission period is reduced by the common-mode voltage. Therefore, a large common mode voltage causes a large current in the transformer.

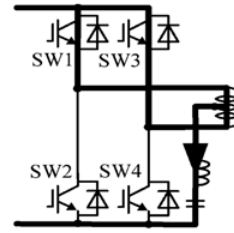

Fig 3. Common mode

Transformer current consists of the common-mode current, which is the buffer current, and the differential-mode current. The common-mode current increases while S1 and S2 are turned on, and decreases during differential mode, because the capacitor voltage is greater than half of the dc voltage.

**Principle of Operation**

In order to suppress the ripple current of the DC source, all the current ripples are provided by the energy buffer capacitor. Therefore, the capacitor Current is obtained by calculating the power ripple. The capacitor current  $I_{com}$  in the active buffer is controlled by a proportional integral (PI) regulator to agree with the capacitor current  $I_{com}$ , and the dc active filter voltage  $V_{com}$  is output by the PI regulator. In order to obtain the maximum terminal voltage of the transformer, the differential-mode voltage  $V$  is set maximum value.

However, the output period of the common-mode voltage is limited by the output period of the differential mode, i.e., the duty ratio  $D_{dif}$  for the differential mode can be constrained by where  $D_{com}$  is the duty ratio for the common-mode voltage.

The energy buffer capacitor  $C_r$  is connected to the center tap of a medium frequency transformer.

$$D_{dif} + D_{com} = 1 \quad (1)$$

The transformer current  $I_{tran}$  is equaled to the sum of the active filter current  $I_{com}$  and the current  $I_{dif}$ , according to the output power shown in

$$I_{Tran} = I_{dif} + I_{com}/2 \quad (2)$$

The common-mode voltage controls the capacitor voltage variation, and the differential-mode voltage controls the transformer current.

**Single-phase PWM full-bridge inverter and DC active filter function**

As the capacitor voltage variation increases smaller active filter capacitor  $C_r$  can be achieved. However, as the capacitor voltage variation becomes larger, it results in a system that requires a large current capacity transformer.

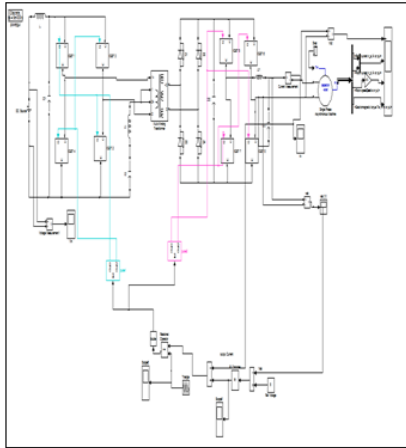

Fig 4. simulink model of proposed circuit

The auxiliary inductor is connected to the center tap of the transformer, because the leakage inductance of the transformer is not sufficient to reduce the switching ripple current. A sinusoidal grid current waveform and unity power factor are obtained; however, the dc input current has a large ripple current component of 100 Hz.

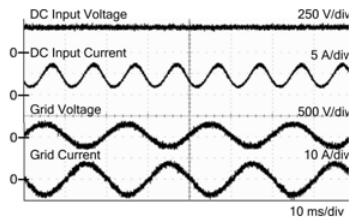

Fig 5. Operation waveforms of the proposed circuit

The ripple of the dc input current is suppressed to 20% that of the conventional circuit, which indicates that the dc active filter function is effective. The grid current waveform maintains the sinusoidal waveform and unity power factor.

The major harmonic component in the input current is 100 Hz. In a conventional circuit, the dc input current THD increases according to the increment of the output power. In contrast, the dc input current THD decreases despite the increment of the output power in the proposed circuit, i.e., the proposed circuit is suitable for high-power applications, due to its effectiveness in the high-output power region.

One of the reasons for the increase in power loss is the increasing current in the transformer [3]. Therefore, the efficiency of the proposed circuit can be improved if the design of the transformer is optimized. Note that the proposed converter has good performance as a grid interconnection converter, because both power factors of the proposed circuit and the conventional circuit are 99%

**Simulation results**

The Simulation results confirm that the proposed converter is valid for the reduction of the DC input ripple current in a DC power supply, without the need for large electrolytic capacitors. The ripple current is suppressed by the

common-mode voltage control of the dc/dc converter, and the main power flow is controlled by the differential-mode voltage.

**Design values**

- Capacitor  $C_{dc1} = 39nF$
- Capacitor  $C_{dc2} = 110pF$
- Buffer Capacitor  $C_f = 440\mu F$
- Buffer Inductor  $L_f = 5mH$
- AC Link Frequency = 10KHz
- Grid Frequency = 50Hz

The following fig.6 shows the gating signals for each IGBT at 50Hz fundamental frequency.

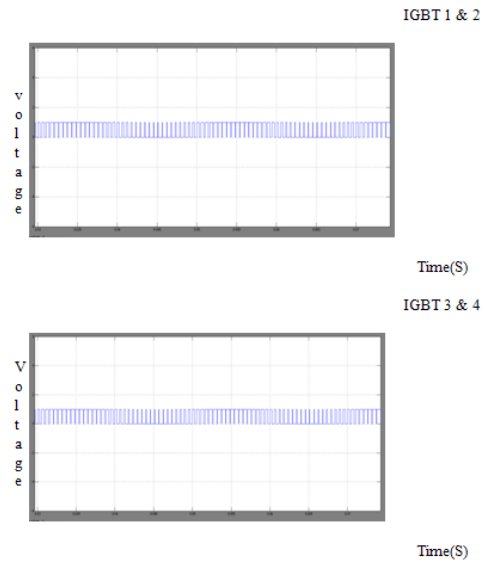

Fig 6. Gating signals

Simulation results predict waveforms across input and the load side. The proposed circuit was designed with filter elements connected in DC side. Triggering pulse was generated using PWM technique by comparing reference and carrier signal shown below. Fig 7..

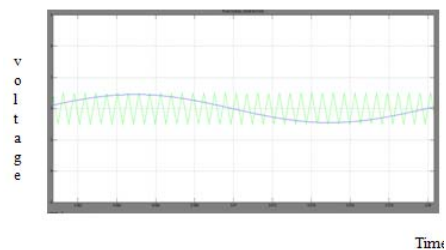

Fig 7. PWM Signal generation

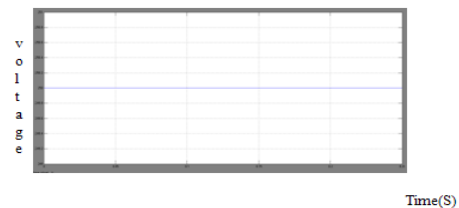

Fig.8.DC input voltage 250V

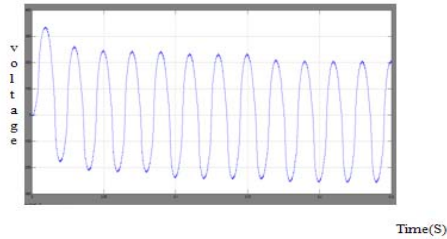

Fig 9. Inverter AC output voltage 400V

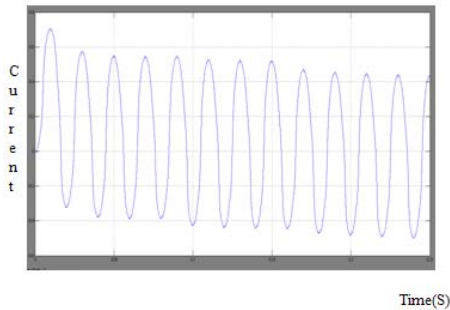

Fig 10. Inverter AC output current 0.8 A

Single-phase full-bridge DC–AC inverter circuit that has been used in the study. The inverter is implemented with a sinusoidal pulse width modulation (PWM) method at 20kHz switching to ensure a clean output voltage [4].

With a linear load, the output current has the same 50Hz frequency and sinusoidal wave shape as the output voltage. The inverter input voltage and current are DC, but the current contains high frequency switching noises and a low frequency ripple component. The ripple component is considered the rectification effect through the inverter switches, and thus it appears to be a 100 Hz pulsating current.

The PWM switching noise is filtered with a high-frequency dc bus capacitor, but the energy of the 100 Hz ripple is too high to be absorbed.[4]. A bulky DC bus capacitor can then be used to smooth the 100-Hz ripple, but a significant part of the 100-Hz ripple remains and continues to propagate through the entire DC–DC converter and back to the DC source.

Therefore, the configuration is often referred to as an active parallel filter[5]. It illustrates the concept of the harmonic current cancellation so that the current being supplied from the source is sinusoidal. The voltage source inverter used in the

active filter makes the harmonic control possible. This inverter uses dc capacitors as the supply and can switch at a high frequency to generate a signal which will cancel the harmonics from the nonlinear load.

### Conclusion

A novel single-phase isolated converter was proposed for grid interconnection applications. The ripple current in a dc power supply, such as a fuel cell, battery, or photovoltaic cell, can be reduced by the appropriate operation of a dc active filter. The main feature of the proposed circuit is that it does not require additional switching devices, because the zero vector of the first-stage inverter is controlled as the dc active filter.

- 1) The ripple current can be decreased to 20% that of the conventional circuit.
- 2) The proposed circuit shows a degree of effectiveness for high output power applications.
- 3) The total electrolytic capacitor requirement of the system is decreased to 25% that of the conventional circuit.
- 4) The dc active filter operation in the proposed method circuit does not interfere with the grid interconnection current control.

In future work, optimization of the transformer and construction of a high-power prototype will be proceeded.

### References

- [1] S. Sumiyoshi, H. Omuri, and Y. Nishida, "Power conditioner consisting of utility interactive inverter and soft-switching DC–DC converter for fuel-cell cogeneration system," Nagoya, Japan, pp. 455–462.
- [2] J.-M. Kwon and B.-H. Kwon, "High step-up active-clamp converter with input-current doubler and output-voltage doubler for fuel cell power systems," , vol. 24, no. 1, pp. 108–115..
- [3] X. Ma, B. Wang, F. Zhao, G. Qu, D. Gao, and Z. Zhou, "A high power low ripple high dynamic performance DC power supply based on thyristor converter and active filter," pp. 1238–1242.
- [4] M. Saito and N. Matsui, "Modeling and control strategy for a single-phase PWM rectifier using a single-phase instantaneous active/reactive power theory," pp. 573–578.
- [5] M. Pereira, G. Wild, H. Huang, and K. Sadek, "Active filters in HVDC systems: Actual concepts and application experience," pp. 989–993