



An analysis of some major antennas using frequency 750 MHz to 850 MHz

Rajesh Shirvastava¹ and A.K. Shrivastava²

¹ Research Scholar, Dr.C.V.Raman University, Kota, Bilaspur (C.G.), India.

² Professor & Head, Department of Physics, Dr.C.V.Raman University, Kota, Bilaspur (C.G.), India.

Abstract

An antenna is transducer, an impedance matching device, a radiator and a sensor of electromagnetic waves. It is essential device/element in all types of communication and radar systems. It can be considered as a source of electromagnetic wave. In this research paper an attempt has been made to study the characteristics of major antenna using frequency from 750MHz to 850MHz. In this experiment as well as research ATS-B Antenna system trainer is utilized. An antenna (or aerial) is an electrical device which converts electric power into radio waves, and vice versa. It is usually used with a radio transmitter or radio receivers. In transmission, a radio transmitter supplies an oscillating radio frequency electric current to the antenna's terminals, and the antenna radiates the energy from the current as electromagnetic waves (radio waves). In reception, an antenna intercepts some of the power of an electromagnetic wave in order to produce a tiny voltage at its terminals, that is applied to a receiver to be amplified. Typically an antenna consists of an arrangement of metallic conductors (elements), electrically connected to the receiver or transmitter. As oscillating current of electrons forced through the antenna by a transmitter will create an oscillating magnetic field around the antenna elements, while the change of the electrons also creates an oscillating electric field along the elements. Antenna can be broadly classified by the directions in which they radiate or receive electromagnetic radiation. They can be isotropic, omni-directional or directional. An antenna is chosen for a particular application according to its main physical and electrical characteristics. Further an antenna must perform in a desired manner for the particular application. An antenna can be characterized by the following key factors, not all are applicable to all types of antenna. Main characteristics of an antenna are: radiation resistance, radiation pattern, the bandwidth etc. Further it has been found that graph of antenna polar plot which describes about antenna characteristics. Antennas are essential components of all equipment that uses radio. They are used in systems such as radio broadcasting, broadcast television, two-way radio, communication receivers, radar, cell phones, and satellite communication, as well as other devices such as garage door openers, wireless microphones, Bluetooth enabled devices, wireless computer networks, baby monitors, and RFID tags on merchandise. This paper introduces antenna theory and discusses various antenna types and applications. The basic equations and principles of antenna theory are presented. Five different types of antennas are introduced: dipoles and monopoles, loop antennas, microstrip antennas, helical antennas, and horn antennas. The characteristics of each type of antenna are given.

Keywords: Frequency, transmitter, receiver, electromagnetic radiation, radiation pattern etc

INTRODUCTION

The broadest definition of an antenna is that it is a transducer it changes energy from one form into another. A receiving antenna changes electromagnetic energy into electric or magnetic energy. A transmitting antenna changes the energy from electric or magnetic into electromagnetic energy. Current flowing in the antenna induces the electric and magnetic fields. Antennas have been used for over a century in a variety of applications. They can transmit over a massive range of frequencies, from a fraction of a kilohertz to over one hundred gigahertz. This paper will give a brief introduction to antenna principles, and then discuss various antenna types and their applications.

Basic antenna principles Antenna Parameters

There are five basic parameters that one must understand to determine how an antenna will operate and perform. The first is the characteristic of *radiation resistance*. The radiation resistance (R_{rad}) of an antenna relates the power supplied (P_{rad}) to the antenna and the current (I) flowing into the antenna. The equation for radiation resistance is given in (1). As can be seen, the greater the radiation resistance, the more energy is radiated or received by the antenna. When the radiation resistance of the antenna matches the resistance of the transmitter or receiver, the system is optimized. Antennas also have ohmic or loss resistance which decreases efficiency. It can be shown that an efficient antenna must be comparable to a wavelength in size.

$$R_{rad} = \frac{P_{rad}}{I^2} \quad (1)$$

A second parameter of antennas is the *antenna pattern*. This gives a distribution of radiated power as a function of direction in space. Generally, planar sections of the radiation pattern will be

*Corresponding Author

Rajesh Shirvastava
 Research Scholar, Dr.C.V.Raman University, Kota, Bilaspur (C.G.), India.

Email: rajesh_shri2008@yahoo.com

shown instead of the complete three-dimensional surface. The most important views are those of the principal E-plane and H-plane patterns. The E-plane pattern contains the plane in which the electric field lies. Similarly, the H-plane pattern is a sectional view in which the magnetic field lies. An example of each type is shown in Figure 1, which gives the antenna pattern for a half-wave dipole orientated in the z-direction.

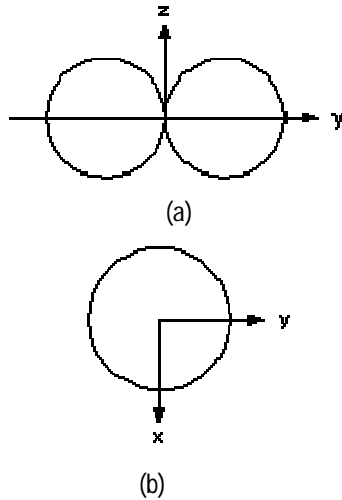

Fig 1. (a) Dipole Principal E-plane Pattern (b) Dipole Principal H-plane Pattern

Most antennas do not radiate uniformly, as seen in Figure 1a. This implies that there is some *directivity*, which is the third parameter. Closely related to this is the *gain* of the antenna. The directivity is a measure of the ability of an antenna to concentrate the radiated power in a given direction. The gain is similarly defined. Usually given in decibels, it is the ratio of power radiated to input power. Thus, using an antenna with a higher gain would require less input power. Gain is a more significant parameter in practice than the directivity.

Bandwidth is another important antenna parameter. This refers to the inclusive frequencies available outside the center frequency. For example, a 10 MHz transmitter with a 10% bandwidth could send information on frequencies from 9 MHz to 11 MHz. This is important to Frequency Modulated (FM) signals, as they require modulation about the carrier frequency in order to send data.

The final antenna parameter is the *signal-to-noise ratio*. This is the relationship between the desired information signal and the noise. If this ratio does not exceed unity, information will not be transferred. Noise can be caused by obstructions, large distances between antennas, and environmental RF noise, such as power supplies and digital switching devices.

Electromagnetic Energy Calculations

An antenna's electric and magnetic fields can be calculated at any point, but the equations are not simple. A short current filament generates the fields shown in (2), (3), and (4), given in spherical coordinates. Because of the complexity of these equations, most problems involving antennas are solved by experimental rather than theoretical methods.

$$H_{\phi s} = \frac{I_0 d}{4\pi} \sin \theta e^{-j2\pi r/\lambda} \left(j \frac{2\pi}{\lambda r} + \frac{1}{r^2} \right) \quad (2)$$

$$E_{rs} = \frac{I_0 d \eta}{2\pi} \cos \theta e^{-j2\pi r/\lambda} \left(\frac{\lambda}{j2\pi \cdot r^3} + \frac{1}{r^2} \right) \quad (3)$$

$$E_{\theta s} = \frac{I_0 d \eta}{4\pi} \sin \theta e^{-j2\pi r/\lambda} \left(j \frac{2\pi}{\lambda r} + \frac{1}{r^2} + \frac{\lambda}{j2\pi \cdot r^3} \right) \quad (4)$$

Despite the complexity of these equations, some observations can be made. The exponential factor in each equation is the same. This indicates wave propagation outward from the origin in the positive r direction. The wavelength is equal to λ , and d is the length of the current filament. Also as expected, the strength of the fields is related directly to the peak current, I_0 . The factor η is equal to $120\pi\Omega$ in free space.

At radial distances 10 or more wavelengths away from the oscillating current element, these equations can be simplified. All terms except the $1/r$ term may be neglected, and the radiation fields are given in (5), (6), and (7). Assuming a vertical orientation of the current element, plotting $E_{\theta s}$ against θ for a constant r will result in a graph similar to Figure 1a, called the vertical pattern. Plotting $H_{\phi s}$ shows the variation of field intensity with ϕ , often referred to as the horizontal pattern, such as in Figure 1b.

$$H_{\phi s} = j \frac{I_0 d}{2\lambda r} \sin \theta e^{-j2\pi r/\lambda} \quad (5)$$

$$E_{\theta s} = j \frac{I_0 d \eta}{2\lambda r} \sin \theta e^{-j2\pi r/\lambda} \quad (6)$$

$$E_{rs} = 0 \quad (7)$$

Types of antennas Dipoles and Monopoles

The world's most popular antenna is the half-wave dipole. Shown in Figure 2, the total length of the antenna is equal to half of the wavelength. The relationship between wavelength and frequency is $f = c / \lambda$, where $c = 3 \times 10^8$ m/s in free space. Dipoles may be shorter or longer than half of the wavelength, but this fraction provides the best antenna efficiency. The radiation resistance can be calculated as 73.1Ω .

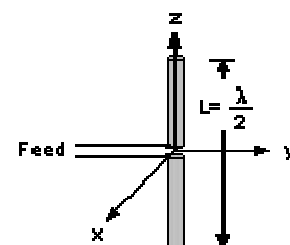

Fig 2. Dipole Antenna, 1/2 Wave

The dipole antenna is fed by a two-wire line, where the two currents in the conductors are equal in amplitude but opposite in direction. Since the antenna ends are essentially an open circuit,

the current distribution along the length of the half-wave dipole is sinusoidal, shown in Figure 3. This produces the antenna pattern shown in Figure 1. This pattern shows that when the antenna is vertical, it radiates the most in the horizontal direction and very little out the ends of the antenna. A typical gain for a dipole antenna is 2dB, and the bandwidth is generally around 10%.

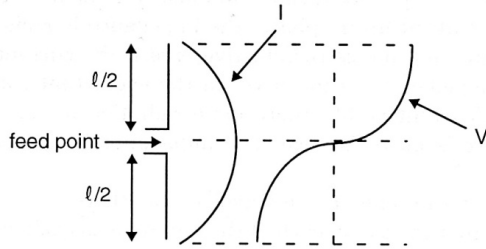

Fig 3. Current and Voltage Distributions for a Half-Wave Dipole Antenna

A monopole antenna is one-half a dipole plus a perfectly conducting plane. It behaves in a similar way to the dipole, but most of its parameters are halved. Figure 4 shows a quarter-wave monopole, also known as the vertical whip antenna.

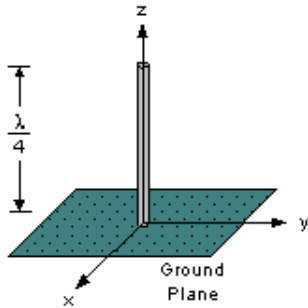

Fig 4. Monopole Antenna, 1/4 Wave

The radiation resistance is 36.5Ω , half that of a dipole. The total power radiated is also half that of a dipole, and the radiation pattern is shown in Figure 5. A typical gain for a monopole antenna is 2 to 6dB, and the bandwidth is also around 10%.

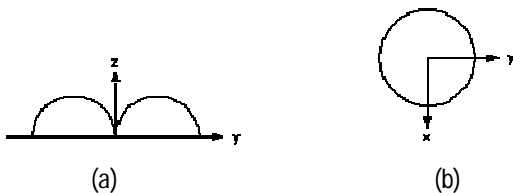

Fig 5. (a) Monopole Principal E-plane Pattern
(b) Monopole Principal H-plane Pattern

Loop Antennas

The loop antenna is a conductor bent into the shape of a closed curve, such as a circle or square, with a gap in the conductor to form the terminals. Figure 6 shows a circular and a square loop. These antennas may also be found as multiturn loops or coils, designed with a series connection of overlaying turns. There are two sizes of loop antennas: electrically small and electrically large. If the total conductor length is small compared with a wavelength, it is considered small. An electrically large loop typically has a

circumference approaching one wavelength.

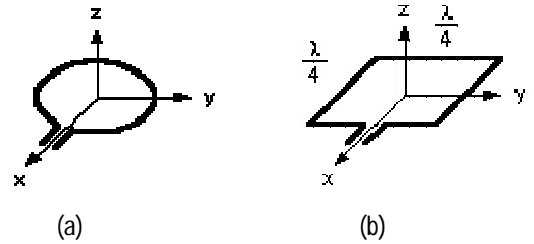

Fig 6. (a) Circular Loop Antenna (b) Square Loop Antenna

The current distribution on a small loop antenna is assumed to be uniform. This allows it to be simply analyzed as a radiating inductor. Used as transmitters, loop antennas have a pattern that follows Figure 7. Loop antennas can have a gain from -2dB to 3dB and a bandwidth of around 10%.

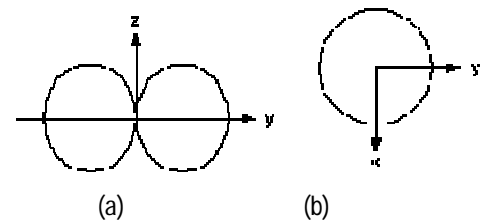

Fig 7. (a) Loop Antenna Principal E-plane Pattern (b) Loop Antenna Principal H-plane Pattern

Loop antennas have found to be very useful as receivers. For low frequencies—where dipoles would become very large—loop antennas can be used. While the efficiency of a small loop antenna is not good, a high signal-to-noise ratio makes up for it. A common method to increase loop antennas' performance is to fill the core with a ferrite. This has the effect of increasing the magnetic flux through the loop and increasing radiation resistance.

Microstrip Antennas

The microstrip or patch antenna is often manufactured directly on a printed circuit board, where the patch is a rectangular element that is photoetched from one side of the board (Figure 8). Most microstrip elements are fed by a coaxial conductor which is soldered to the back of the ground plane. Typically the upper plate conductor is smaller than the ground plane to allow fringing of the electric field. The dielectric substrate between the microstrip and the ground plane is simply the printed-circuit substrate.

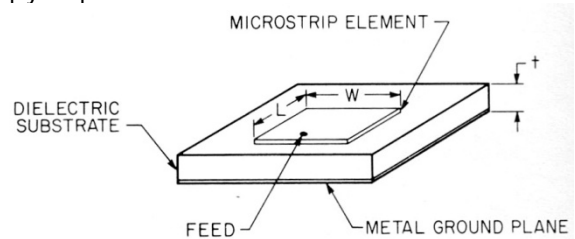

Fig 8. Rectangular Microstrip-Antenna Element

Despite its low profile, the microstrip antenna has an efficient radiation resistance. The source of this radiation is the electric field that is excited between the edges of the microstrip element and the ground plane. The equation for the radiation resistance is a function of the desired wavelength (λ) and the width (W) of the microstrip:

$$R_{rad} = \frac{120\lambda}{W} \tag{8}$$

Microstrip antennas are generally built for devices that require small antennas, which lead to high frequencies, typically in the Gigahertz. Most microstrip elements are very efficient, anywhere from 80 to 99 percent. Factors that affect efficiency are dielectric loss, conductor loss, reflected power, and the power dissipated in any loads involved in the elements. Using air as a substrate leads to very high efficiencies, but is not practical for photoetched antennas.

Helical Antennas

The basic helical antenna consists of a single conductor wound into a helical shape, shown in Figure 9. Helical antennas are circularly polarized, that is, the radiated electromagnetic wave contains both vertical and horizontal components. This is unlike the dipole, which only radiates normal to its axis. Like the monopole, a ground plane must be present.

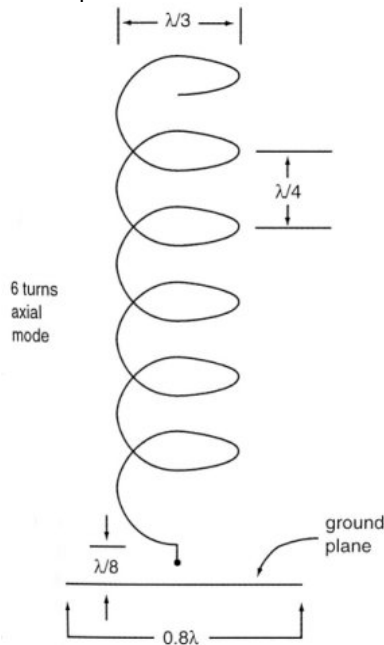

Fig 9. Helical Antenna

The antenna shown in Figure 9 has a gain of about 12dB. It operates in the 100 to 500 MHz range and is fed with a coax where the center conductor is fed through the center of the ground plane. The spacing of the turns is 1/4-wave and the diameter of the turns is 1/3-wave. This is just one example of a helical antenna; they can be scaled to other frequencies of operation as well. Other modifications can be made; nonuniform-diameter helical structures can widen the bandwidth and improve radiation performance.

Horn Antennas

Horn antennas are made for the purpose of controlling one or more of the fundamental antenna properties: gain, antenna pattern, and radiation resistance. A horn antenna works in conjunction with a waveguide—a tube that channels energy from one location to

another. Horn antennas can have several shapes, depending on their function. Several are shown in Figure 10.

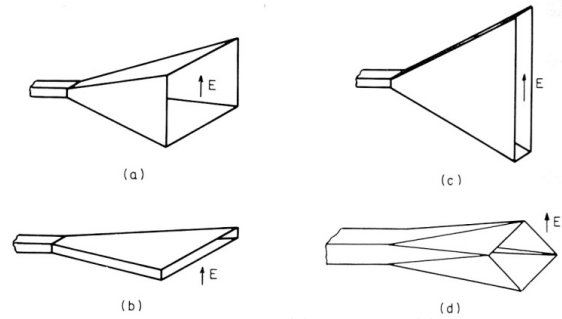

Fig 10. Rectangular –Waveguide Horns (a) Pyramidal (b) Sectoral H-plane (c) Sectoral E-plane (d) Diagonal

The pyramidal horn in Figure 10a is used to maximize the gain, since the antenna is flared in both the H-plane and E-plane. This obviously gives the antenna a fixed directivity, and it will radiate principally in the direction of the horn's axis. Figures 10b and 10c are special cases of the pyramidal horn, where either the H-plane or E-plane is flared thus and maximized.

Antenna applications

Only a handful of antennas have been introduced in the previous section. There are numerous variations on these basic antennas, as well as many different shapes. Antennas also have countless applications—many more than can be covered in this paper. This section will discuss some of the more familiar antenna applications.

VHF and UHF Antennas

The very-high-frequency (VHF) and ultra-high-frequency (UHF) bands are used for private and public-access services carrying speech and data. There are a wide variety of applications and many different types of antennas. For a typical base-station antenna, such as for a television or radio station, the transmitter must be large to achieve the desired frequency and provide a large range of coverage. The VHF and UHF bands cover frequencies from 3 MHz to 3000 MHz and include television and FM radio broadcasting. It is common that antennas will share a tower, resulting in a candelabra structure like Figure 12.



Fig 11. ¼-Wavelength Retractable Two-In-One Antenna (a) Extended (b) Retracted

TV and FM Receiving Antennas

The most common type of VHF and UHF receiving antenna is a Yagi array antenna. Figure 13 shows a combination UHF/VHF/FM receiving antenna. The array of different size conductors is necessary to receive different frequencies. Yagi arrays are highly directional, so the antenna should be pointed towards the transmitting antenna.

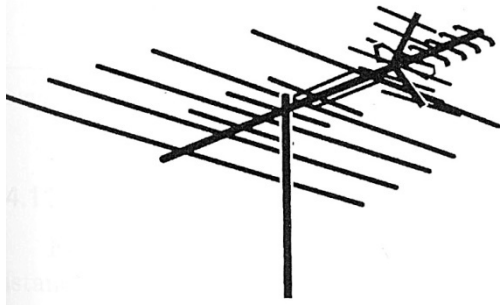

Fig 12. UHF/VHF/FM Antenna

Wireless Communications Applications

Mobile communication, wireless interconnects, and cellular phone technologies are growing rapidly. Naturally, mobile and cellular technologies need antennas. Having the right antenna for the right device improves transmission and reception, reduces power consumption, and lasts longer.

The most common antenna type for cellular telephones is the monopole, often referred to as a whip antenna. The $\frac{1}{4}$ -wavelength whip is the simplest type available and is used in the 400 to 500 MHz range. Other similar types are the $\frac{3}{8}$ -wavelength whip antenna and the $\frac{1}{2}$ -wavelength whip antenna. These are larger than the $\frac{1}{4}$ -wavelength antenna but have improved performance.

Another common type used in wireless applications is the helical antenna. The $\frac{1}{4}$ -wavelength helical antenna is shown in Figure 11. It is smaller than the whip and has similar performance. Lately it is used in the 800 to 1000 MHz cellular bands.

Retractable antennas are frequently used in cellular phones as well. Figure 12 shows a $\frac{1}{4}$ -wavelength retractable two-in-one antenna. There are actually two separate antennas, which are

electrically decoupled. In the extended position, the antenna functions as a whip. In the retracted position, it works as a helical antenna. The performance is slightly better in the extended position.

CONCLUSIONS

Antennas are devices that change electromagnetic energy into electric or magnetic energy or vice versa. The equations describing antenna behavior are complicated, and engineers use experimental measurements and data in most antenna design work. There are many different types of antennas, and this paper introduced just a few of the basic shapes: dipoles, monopoles, loops, microstrips, helicals, and horns. Each type of antenna has certain characteristics that are important to determining its behavior: radiation resistance, antenna pattern, directivity and gain, bandwidth, and the signal-to-noise ratio. Antennas are used in numerous applications. A few were as VHF and UHF antennas, TV and FM receiving antennas, and some wireless applications.

REFERENCES

- [1] William H. Hayt, Jr. and John A. Buck, 2001. Engineering Electromagnetics, Sixth Edition, McGraw-Hill.
- [2] Leo Setian, 1998. Practical Communication Antennas with Wireless Applications, Prentice Hall.
- [3] Robert E. Collin, 1985. Antennas and Radiowave Propagation, McGraw-Hill.
- [4] RF Café, "Antenna Patterns," 2000. http://www.rfcafe.com/references/electrical/antenna_patterns.htm
- [5] The United States Navy Fact File, "Extremely Low Frequency Transmitter Site Clam Lake, Wisconsin," http://enterprise.spawar.navy.mil/spawarpublicsite/docs/fs_clam_lake_elf.pdf
- [6] Rick Warnett, "Stations, ITU Licenses And Services Below 22kHz," <http://web.tiscali.it/vlradio/itulist/itulist.htm>
- [7] Richard C. Johnson and Henry Jasik, 1984. Antenna Engineering Handbook, Second Edition, Mc-Graw Hill.