

The Ubiquitous Model for Dynamic Diffusion of Information Technology

著者	Takada Hirokazu, Saito Kaichi, Terui Nobuhiko, Yamada Masataka
journal or publication title	DSSR Discussion Papers
number	36
page range	1-51
year	2015-02-23
URL	http://hdl.handle.net/10097/65012

DSSR

Discussion Paper No. 36

The Ubiquitous Model for Dynamic Diffusion of
Information Technology

Hirokazu Takada, Kaichi Saito, Nobuhiko Terui,
and Masataka Yamada

February 23, 2015

Data Science and Service Research
Discussion Paper

Center for Data Science and Service Research
Graduate School of Economic and Management
Tohoku University
27-1 Kawauchi, Aobaku
Sendai 980-8576, JAPAN

The Ubiquitous Model for Dynamic Diffusion of Information Technology

Hirokazu Takada, Kaichi Saito, Nobuhiko Terui, and Masataka Yamada*

February 23, 2015

*For correspondence, please contact Hirokazu Takada, Professor of Marketing, Zicklin School of Business, Baruch College/CUNY, Box B12-240, One Bernard Baruch Way, New York, NY 10010, 646-312-3289 (office), 646-312-3271 (fax), Hirokazu_Takada@baruch.cuny.edu. Kaichi Saito is Associate Professor of Marketing, Department of Economics, Meiji Gakuin University, Tokyo, Japan. Nobuhiko Terui is Professor, Graduate School of Economics and Management, Tohoku University, Kawauchi, Aoba-ku, Sendai, 980-8576, Japan. Masataka Yamada is Professor of Marketing, Faculty of Commerce and Business, Nagoya University of Commerce and Business, Nissin, Aichi, 470-0193, Japan.

The Ubiquitous Model for Dynamic Diffusion of Information Technology

ABSTRACT

The recent information technology products with capability of performing multiple functions owing to the digital convergence, e.g., smart phones with fast Internet connection, provide ubiquitous access to the Internet for consumers. To model diffusion processes of such products and services requires a comprehensive modeling framework. We address major issues in the framework which include the consumer heterogeneity of diffusion modeling and market segmentation determined by the adoption process, the need for more generalized model than the successive generation substitution theory, the distinction of the adoption processes based on the sequence of adopting different technologies, and the network externalities.

The comprehensive diffusion model based on the Bass Model was proposed, and the hierarchical Bayesian model was formulated for estimation. We conjecture that a segment could be defined by the process of how consumers adopt the IT service, and we develop the diffusion models for each of the segments. The proposed model thus consists of those segment specific models, and is capable of identifying the market potential for each segment.

The empirical analysis using data on Internet subscriptions via PC and digital cellular phone in the U.S. and Japan shows that the proposed model can capture the interactive effect between two diffusion processes, and provides an excellent fit to the data. The hypotheses developed in the theoretical framework are supported, and we discuss theoretical contributions and managerial implications.

Key words: Diffusion, segmentation, Bass model.

Everlasting quest for the ubiquitous access to the Internet leads to the innovation of newer generation digital information products. Smartphones, such as iPhones and Android Galaxies, could be an answer to satisfy these needs by delivering faster and ubiquitous access to the Internet with multiple capabilities attributable to the concept of digital convergence, i.e., the technological development of converging multiple functions into a single digital device. Meanwhile, as processing huge amount of information available in the cyber space on portable devices is getting quite cumbersome, more powerful devices such as desktop PCs may be a better choice despite lacking portability. Laptop devices may bridge the gap between smartphones and desktop PCs. How people are trying to achieve accessing the Internet may involve various adoption patterns of these devices. The objective of this study is to try to build the comprehensive diffusion model of those adoption behaviors for the access to the Internet. Our interest is not in the unit sales of these devices, but the subscription to the Internet by these devices. Building such a diffusion model is not a simple task because the adoption pattern may involve more than a single device, and people may switch devices back and forth depending on the situation. The widely used Bass model could be applied to this situation. However, the substitution model by Norton and Bass (1987) deals with only the switching behavior of adoption from an old to a new generation, but not vice versa. Consider the scenario under which people are using the desktop PC for their access to the Internet. Those consumers may later add the cellular phone to supplement their access to the Internet. Since those people adopted their cellular phone after the PC, the cellular phone could be considered as the newer generation device as opposed to the PC as the old generation. The NB model could capture this sequence from an old to a new generation adoption. However, people are not quite abandoning their old PCs, and rather they are using both devices as needed. This means that the NB model needs to

be extended to cope with a sequence of usage of a new generation product as well as an old generation product. This is just a single example of the daunting tasks that we need to deal with to construct a comprehensive diffusion model.

Theoretical underpinning of our proposed model lies in the behavioral premise that adopters would be grouped into different segments based on how they choose devices to access to the Internet. The majority of diffusion models use the macro level of data by aggregating adopters. We conjecture that the likely adoption process of gaining Internet access at the micro level can be used as the segmentation base to group adopters into distinct segments. By aggregating the segment level diffusion models we come up with the comprehensive unified model. As the proposed model thus consists of separate models which corresponds to diffusion processes of different market segments, we formulate the simultaneous equation model.

Despite the increasing amount of diffusion research (for review of diffusion research literature, see Muller 2014 and Peres, Muller, and Mahajan 2010), to the best of our knowledge, the unified and comprehensive modeling to disentangle complex diffusion processes of accessing the Internet via different devices built upon the behavioral premises of segmentation is the first attempt.

The limited number of observations available for estimation often confronts researcher in diffusion studies. Our solution to this problem is to develop the hierarchical Bayesian (HB) model. It is well known that the HB model is capable of yielding very effective and efficient estimation results, and has been widely applied to marketing studies, but not so in diffusion studies.

Empirical analysis using the subscription data in the U.S. and Japan yields the plausible results with excellent fit to the data which lend support to the majority of hypotheses developed

in the theoretical framework, confirming the existence of the large segment of consumers who are utilizing different devices to achieve ubiquitous access to the Internet.

In the following sections, we present the theoretical and modeling framework, followed by the proposed model and empirical results. We derive managerial implications based on the empirical results, and conclude with discussions on the limitations of this study along with directions for future research.

Theoretical and Modeling Framework

We organize the theoretical and modeling framework proposed in this study with respect to the following six major areas: (1) consumer heterogeneity and segmentation to be defined by adoption process, (2) the successive segmentation substitution theory and the need for more generalized and comprehensive model, (3) identification of initial and conditional adoptions, (4) diffusion acceleration and the learning effect hypothesis, (5) cross-country diffusion research, and (6) the network externalities. The proposed framework, along with the pertinent literature, empirical results, and implications, is summarized in Table 1

[Insert Table 1 about here]

Consumer Heterogeneity and Segmentation

We conjecture that the market consists of different segments, thus assuming a heterogeneous market, as opposed to the underlying assumption among the prior diffusion models as a single potential market with one user segment. Our approach based on the heterogeneous market assumption is to bridge the gap between the homogeneous market assumption and the individual based assumption for modeling of the diffusion processes.

We define the segments by identifying the patterns of gaining Internet access, i.e., how consumers access the Internet. For illustrative purpose, we follow the previous scenarios of

accessing the Internet by PC or cellular phones, or utilizing both devices, as illustrated in Figure 1 where two segments, namely the *independent* and *ubiquitous* segments, are identified. *The independent segments* consist of subscribers either utilizing their PCs or cell phones alone. *The ubiquitous segment* corresponds to the overlapping area where subscribers are using both devices. Furthermore, those subscribers are divided into two groups depending upon the sequence of which device is chosen for access to the Internet.

[Insert Figure 1 about here]

We do not label the ubiquitous segment as the complementary segment, since the ‘complementarity’ in economics literature is defined in contrast to the substitution, and the former refers to the case where a product requires another product to function properly, e.g., DVD players and software, PC and the operating system with software. The ubiquitous segment definition is thus to better represent the characteristics of this segment.

Ubiquitous segment hypothesis (H1). We expect that the ubiquitous segment would be the dominant and growing segment, larger than the aforementioned independent segments. We derive this hypothesis based on behavioral and technological rationales. First, consumers’ preference for being connected to the cyberspace is easily comprehended because of growing popularity of cyber communication and huge amount of information available on the Internet. Formally this is explained by the concept of network externality which we will explore further in the subsequent section. Simply put, the network externality posits that the more consumers are connected to each other, the higher pressure consumers feel to adopt the innovation so as to facilitate communication via the same type of innovation. Thus network connectivity enabled by PC and cell phone in the ubiquitous environment is expected to stimulate non-adopters to adopt the same technology.

Second, the rapid advancement of IT products/services is likely to induce consumers to yarn faster and convenient communication and connection in 24/7 and at anywhere possible. Recent 4G technology enabled cell phones and smartphones enable consumers to achieve higher level of ubiquitous communication.

In summary, the proposed model attempts to capture diffusion processes by conjecturing that these different segments are gaining access to the Internet with varying sequence of using technologies. The comprehensive models were formulated by aggregating the specific models for each of the segments into the unified simultaneous equation model. This approach is consistent to the study by Wind, Robertson, and Fraser (1982) which contends that if the diffusion patterns vary by segment, the single market assumption is inappropriate. Furthermore, marketing plan and forecasting of new technologies can be improved by properly understanding the market heterogeneity caused by the different segments. The proposed model is capable of identifying various characteristics of different segments from the aggregate data, whereas the previous studies require separate data for each segment.

From the Successive Generation Substitution Theory Model to the Comprehensive Model

The successive generation substitution model developed by Norton and Bass (1987) along with the subsequent extended studies has a significant contribution to the literature by expanding the arena of diffusion research on the high technology innovation. The basic premise of NB model is that a new product is technologically more advanced and attractive than an existing product, such that consumers are switching to the new product. The NB model is, thus, developed based upon the homogeneous segment assumption in which all the consumers adopt the new generation of the product, and does not explicitly consider the existence of the multiple

heterogeneous segments. Therefore, the restrictive homogeneous segment assumption needs to be extended to fully cope with the heterogeneous adoption behaviors across various segments.

In order to capture the recent phenomena of ubiquitous access via multiple devices with the mixed generations, the new models will be called for, since the ubiquitous segment is utilizing the existing (e.g., PC) as well as the new generation devices (e.g., the cellular phone) simultaneously to satisfy their desire of ubiquitous access to the information in the cyberspace. The proposed model is formulated by expanding the NB model within a more comprehensive framework.

The Conditional Adoption Concept for the Ubiquitous Segment

Adoption process of subscribing to the Internet would become complex if consumers attempt to gain access ubiquitously using different devices. We introduce the concept of initial and conditional adoption process in the proposed model. The *initial* adoption refers to the case in which consumers first adopt the innovation, whether the adopted innovation could be an existing or newly introduced device/service. Whenever consumers start the Internet access with either PC or cellular phone, this is defined as the initial adoption, as illustrated in Figure 2, where time horizon of the horizontal axis spans from the time when an Internet access by PC became available ($\tau_p = 0$). The time when an Internet access by cell phones became available is denoted by (τ_c).

[Insert Figure 2 about here]

The *conditional* adoption occurs within the ubiquitous segment where consumers with the initial adoption subsequently add another innovation, whether an added innovation could be an existing or newly introduced device/service, so as to facilitate their desires to gain ubiquitous access to the Internet. The conditional adoption is thus defined as the adoption conditional upon

the initial adoption. For example, if the PC subscription is the initial adoption for consumers in the ubiquitous segment, their subsequent conditional adoption is the cellular subscription to the Internet access. The proposed model can deal with both cases, i.e., the initial adoption could be the cellular or PC subscription, similarly for the conditional adoption as well within the ubiquitous segment.

Accelerating Diffusion among the Ubiquitous Segment

We hypothesize that consumers within the ubiquitous segment would accelerate the conditional adoption process because of the learning effect derived from the prior experience with the initial adoption. ***The accelerating hypothesis (H2)*** is consistent with the diffusion theory (Rogers, 2003) and international diffusion literature that diffusion rate is accelerated for the innovation later introduced across different countries because of the time and learning effect (Putsis, Balasubramanian, and Sen 1997). The proposed model is formulated to measure the initial and conditional adoption rates separately, thus enabling the hypothesis test of this effect.

Cross-country Diffusion Research

In order to contribute to the empirical generalization (Bass 1995, Ehrenberg 1995), we conduct the empirical analysis using the aforementioned subscription data collected from the United States and Japan, the culturally vastly different yet the largest economies in terms of GDP among the non-communism countries in the world. The parameter estimates will be examined in the context of the cross-country diffusion research findings.

The flattening effect hypothesis (H3). We contend that the diffusion process of the IT products/services across different countries tend to exhibit similar patterns, resulting comparable parameter values, the so-called *flattening phenomenon* of diffusion of the information technology products in the global market (Friedman 2006), whereby the diffusion process of these products

tends to exhibit a converging, rather than varying, pattern between the different countries. The major rationale behind this hypothesis stems from the glowing global communication across countries generate the homogenized preferences and tastes among consumers, in particular among younger generation for their desire to adopt high tech products with standardized features. This is contrary to the prior findings in the cross country diffusion research literature (Putsis, Balasubramanian, and Sen1997, and Gatignon, Eliashberg, and Robinson1989) that parameter estimates tend to vary across countries reflecting differences of macro environment factors such as socio-cultural, economic, geopolitical, and technical environments in the countries. The flattening effect hypothesis is in accord with the premise of standardization strategy in the international marketing research literature that an existence of the homogenized segments across various countries lends support for its strategy leading to the lower cost and better control for multinational firms (Levitt 1983). This converging diffusion pattern is expected to emerge whether diffusion occurs across countries with or without time lags of certain magnitude.

Network Externalities

The network externalities are extensively studied by marketing scholars (c.f., the references therein Goldberg, Libai, and Muller 2010) since the notion of the network effect was first introduced in economic literature (Rohlf's 1974). The IT products, such as the Internet, PC, and cellular phones, are well recognized to exhibit a higher level of direct network externalities, wherein the utility that a consumer derives from buying a product or service is directly affected by the number of other users, as opposed to the indirect network externality in which the utility depends on the number of other users of complementary products (e.g., Katz and Shapiro 1985). Consequently the primary focus of this study is on the direct network externalities.

The diffusion studies in the marketing literature with rigorous investigation into the network externalities are sparse, despite that the well-recognized existence of the network externalities, due to several grounds. First, the Bass model formulation already captures the network externality as well as other effects with its imitation coefficient (q), since Bass (1969) conceptualizes that imitators are influenced by the number of previous buyers, i.e., the direct network externality effect, although the network externality was not mentioned in his original paper since his original paper was published earlier than the network externality has been investigated in the economic literature. Second, identifying the network effects by disaggregating the parameters into the network effects and other components sounds theoretically appealing, but it is a formidable task to recover the network externalities from the Bass model parameter estimates with aggregate data, because the network externalities deal with the individual contagion effects, and thus require the micro level individual data in order to properly capture interactions among consumers, whereas the studies based on the Bass model including the current research employ the aggregate data for estimating parameters.

The study by Goldenberg, Libai, and Muller (2010) is cited among the first in the literature to try to separate the word-of-mouth process from network effects in the diffusion of new products by developing an agent-based cellular automata model (Stremersch, Lehmann, and Dekimpe 2010). Nonetheless commentaries on this study raise limitations associated with the study, such as the effect of threshold on the empirical evidence of the chilling effect as an artifact rather than the true state of diffusion network externalities. Authors state that agent-based models are equivalent to the discrete version of the Bass model if a homogenous population and large market potential are assumed. Our study is explicitly dealing with the heterogeneous population, namely different segments defined by the adoption processes of innovation.

The network effect hypothesis (H4). Based on these reviews and considerations, we have decided to investigate the direct network externality, separately from the proposed model formulation. Furthermore, we must note that since the primary objective of this study is to develop the ubiquitous diffusion model based on the segments, the extension of the already complex proposed model does not warrant for a more complex modeling with extra parameters. Nonetheless, empirical investigation of the network effect based on the well-established methodology in the literature still calls for in our study. We hypothesize that the positive direct network effect exists in our study.

Models

As outlined in the theoretical framework in Table 1 and illustrated in Figure 1, we consider that the market consists of the following four segments: two independent and two ubiquitous conditional segments, and defined as follows:

Independent segments:

Segment PC: Subscribers to the Internet using the PCs, but not via cellular phones.

Segment Cell: Subscribers to the Internet using the cellular phones, but not via PCs.

Ubiquitous conditional segments:

Segment PC-Cell: PC subscribers who subsequently add cellular subscriptions once the cell service becomes available.

Segment Cell-PC: Cellular subscribers who subsequently add pc subscriptions at any time. We assume that PC subscription service has

been available from the beginning of the time horizon under study.

The usual stationarity assumption is in order such that consumers are supposed to remain within a particular segment over the period of interest, and would not shift from the original segment to the other.

As shown in Figure 1, PC subscribers, $S_p(t)$, consist of three segments: an independent PC *Segment* and two ubiquitous conditional *Segments*, and can be expressed as follows:

$$(1) \quad S_p(t) = S_p^{PC}(t) + S_p^{PC-Cell}(t) + S_p^{Cell-PC}(t)$$

Similarly the model for cell phone subscribers, $S_c(t)$, is:

$$(2) \quad S_c(t) = S_c^{Cell}(t) + S_c^{Cell-PC}(t) + S_c^{PC-Cell}(t).$$

where superscripts identify the segment as shown in Figure 1. The model is developed on a discrete time basis, and a time interval $(t-1, t]$ is denoted as, time t . In order to properly account for the interactive effects between these two equations, we formulate the two equations as the simultaneous equation model. The proposed model is more comprehensive than the model by Norton and Bass (1987), and for a comparison purpose between two models, the proposed model can be collapsed to the following equations which are the NB model:

$$(3) \quad S_p(t) = S_p^{PC-Cell}(t),$$

$$(4) \quad S_c(t) = S_c^{Cell}(t) + S_c^{PC-Cell}(t).$$

The first equation corresponds to the first generation model, while the second equation to the second generation model. Our proposed model considers not only the successive generation substitution as in NB model, but also the opposite generation shift from new to old as well.

This is a necessary condition for modeling the ubiquitous segment, because subscribers demand a seamless connection to the Internet utilizing devices from different locations. Another notable difference from the NB model is the unit of measurement as pointed out in the theoretical framework. The NB model uses the unit sales, whereas our model is using the subscription data.

Diffusion Models for Market Segments

We conjecture that the whole adoption process could be classified into the initial and conditional processes, as we defined previously. For an illustration purpose, the PC subscription model (Equation 1) is used. (1) *The initial subscription* process refers to the case where consumers have adopted a PC subscription for the first time. This process occurs within the first two segments: *Segments PC* and *PC-Cell*. (2) *The conditional subscription* process corresponds to the situation where consumers choose the PC subscription after experience with the cell phone subscription, i.e., the PC subscription is conditional upon the prior cell subscription. This adoption process prevails within *Segment Cell-PC*. The distinction between the initial and conditional subscriptions is important because it affects the model development which we describe in the following section.

The initial PC subscribers in Segments *PC* and *PC-Cell*, $S_p^{PC}(t)$ and $S_p^{PC-Cell}(t)$, the first two terms in Equation 1, are derived by multiplying the probability of the initial PC subscription with the potential segment size as follows:

$$(5) \quad S_p^{PC}(t) = m^{PC} \left[F_p^{\text{Initial}}(t - \tau_p) - F_p^{\text{Initial}}(t - \tau_p - 1) \right], \text{ and}$$

$$(6) \quad S_p^{PC-Cell}(t) = m^{PC-Cell} \left[F_p^{\text{Initial}}(t - \tau_p) - F_p^{\text{Initial}}(t - \tau_p - 1) \right]$$

where m^h is the potential market size of segment h ($h = \{PC, Cell, PC-Cell, \text{ and } Cell-PC\}$), analogous to the definition of potential market size of the Bass model, m ; $F_p^{\text{Initial}}(t)$ is cumulative

distribution function of initial PC subscription, and τ_P denotes the time when the PC subscription service becomes available. Since the PC subscription service occurs at the onset of the time considered, $\tau_P = 0$.

The conditional PC subscribers in Segment *Cell-PC* are expressed as follows following Norton and Bass (1987):

$$(7) \quad S_P^{Cell-PC}(t) = m^{Cell-PC} F_C^{Initial}(t - \tau_C - 1) [F_P^{Conditional}(t - \tau_P) - F_P^{Conditional}(t - \tau_P - 1)] \quad \text{for } t > \tau_C$$

where $F_P^{Conditional}(t)$ is cumulative distribution function of conditional PC subscription and τ_C is the time when cell phone subscription service becomes available. Note that $F_P^{Initial}(t - \tau_C - 1) = 0$ for $t \leq \tau_C$.

As previously discussed, the initial subscription by the ubiquitous *Cell-PC* Segment is with cell phone followed by PC subscription. Thus, potential PC adopters in Segment *Cell-PC* is determined by the cell phone subscribers. The term in Equation (7), $m^{Cell-PC} F_C^{Initial}(t - \tau_C - 1)$, shows the cumulative cell phone subscribers, i.e., the potential and actual PC subscribers at time t in Segment *Cell-PC*. The number of conditional PC subscribers in Segments *Cell-PC* is derived by multiplying the potential and actual PC subscribers in the segment and the probability of the conditional PC subscription.

Similarly, the cell phone subscriptions of the initial segment in Equation 2 is:

$$(8) \quad S_C^{Cell}(t) = m^{Cell} [F_C^{Initial}(t - \tau_C) - F_C^{Initial}(t - \tau_C - 1)]$$

The ubiquitous *Cell-PC* and *PC-Cell* segments are as follows:

$$(9) \quad S_C^{Cell-PC}(t) = m^{Cell-PC} [F_C^{Initial}(t - \tau_C) - F_C^{Initial}(t - \tau_C - 1)]$$

$$(10) \quad S_C^{PC-Cell}(t) = m^{PC-Cell} F_P^{Initial}(t - \tau_P - 1) [F_C^{Conditional}(t - \tau_C) - F_C^{Conditional}(t - \tau_C - 1)]$$

The total number of subscribers of PC and cellular subscribers expressed in Equations 1 and 2 can be further specified through substitution of the segment specific terms which we have previously derived in the segment models.

Model Specification and Parameterization

Specification of the cumulative distribution functions of the initial and conditional subscription follows the Bass model with its parameters p and q :

$$(11) \quad F_i^r(t) = \frac{1 - \exp\left[-(p_i^r + q_i^r)t\right]}{1 + \frac{q_i^r}{p_i^r} \exp\left[-(p_i^r + q_i^r)t\right]}$$

where r denotes initial or conditional subscription,

p_i^r = the coefficient of innovation for initial or conditional subscription with the device i which captures an external influence, and

q_i^r = the coefficient of imitation for initial or conditional subscription with the device i which reflects an internal influence.

Therefore, the proposed model includes twelve coefficients: the innovation coefficients ($p_{PC}^{Initial}$, $p_{PC}^{Conditional}$, $p_{Cell}^{Initial}$, and $p_{Cell}^{Conditional}$), the imitation coefficients ($q_{PC}^{Initial}$, $q_{PC}^{Conditional}$, $q_{Cell}^{Initial}$, and $q_{Cell}^{Conditional}$), and the market potentials (m^{PC} , m^{Cell} , $m^{PC-Cell}$, and $m^{Cell-PC}$). As shown in Figure 1, the market potential for PC subscribers is $m^{PC} + m^{PC-Cell} + m^{Cell-PC}$, and for cellular subscribers are $m^{Cell} + m^{Cell-PC} + m^{PC-Cell}$, respectively, and the total sum of potential subscribers is $m^{PC} + m^{Cell} + m^{PC-Cell} + m^{Cell-PC}$ where the latter two terms correspond to the ubiquitous segments.

Proposed Model vs Previous Models

Previous models, such as the models by Kim, Chang, and Shocker (2000) and Peterson and Mahajan (1978), did not explicitly consider various adoption patterns, and the ubiquitous segment was not yet considered in their models, and an identification of the ubiquitous segments (Segments *PC-Cell* and *Cell-PC*) is the first attempt in the literature to our best of knowledge.

Second, the proposed model is capable of identifying and measuring the initial and conditional subscription rates separately. The former is captured by the unconditional probabilities with p_i and q_i as in the traditional Bass model, whereas the latter is captured by the conditional probabilities.

Third, the proposed model can overcome the problems associated with the previous attempt made by Kim, Chang, and Shocker (2000). The market potential of their model for category i is expressed as $m_i(t) = m_i (S_j(t))^{r_{ij}}$, where m_i represents a base factor for the market potential for category i , $S_j(t)$ as the number of subscribers to category j ($j \neq i$), and r_{ij} as a coefficient which captures the impact of the subscriptions to category j on the market potential of category i . Although such a formulation of the market potential is capable of identifying intercategory relationships, it also results in the following problems, as acknowledged by authors: First, the base factor needs to be provided a priori. Thus, fixing the base factor with an inappropriate value may not correctly capture intercategory relationships. Second, in order to forecast the category subscription, the observed subscription data of the other category are required, because the market potential for the category is defined in terms of the subscribers to the other category. Third, since the market potential is defined as a multiplicative form, the initial subscription must be zero as long as the other category has not yet appeared on the market. Authors obtained parameter estimates by setting the number of subscriptions before introduction equal to 1.

Hierarchical Bayesian Estimation for the New Product Growth Modeling

An estimation of the Bass model confronts researchers due to the limited data, and this problem becomes more prevalent when the comprehensive nonlinear model is developed, since the number of parameters increases despite that the data availability remains the same. We experienced an inestimable situation with econometric maximum likelihood estimation in our preliminary analysis, since the number of parameters exceeds the data points.

The hierarchical Bayesian (HB) estimation is proven to be very effective to cope with this type of problem. Since Lenk and Rao (1990) and Sultan, Farley, and Lehmann (1990) applied the Bayesian estimation to their diffusion studies, Talukdar et al (2002) and Lee, Boatwright, and Kamakura (2003) are able to obtain reliable estimates with the Bayesian estimation for their extended diffusion studies. As Putsis and Srinivasan (2000) point out, when little data are available, bringing in auxiliary information is effective to provide sufficient data to estimate reliably. This auxiliary information could include using data on multiple segments or countries, multiple product categories, or incorporating priors on the model parameters.

The use of predictive density for diffusion model shows the additional advantages of employing Bayesian approach. The forecasting with uncertainty expressed as predictive interval by using predictive density adds important managerial benefits for managers facing marketing decisions. In contrast, most previous studies reported only point forecasts. We delineate this advantageous feature in details in the section of predictive performance of estimation results.

Empirical Analysis

Annual data of Internet users via PC and cellular phone in the U.S. and Japan were used for the empirical analysis. The U.S. data compiled by the International Telecommunication Union (ITU) include 14 observations (1990 - 2003) for PC subscribers, and 9 observations (1995

to 2003) for the cellular phone subscribers, respectively. The Japanese data cover 16 observations (1990-2005) for the PC subscribers and 7 observations (1999-2005) for the cellular subscribers. The Japanese data are compiled by the Ministry of Internal Affairs and Communications and the New Media Development Association.

It is a challenge to match international data across countries such that empirical results can be compared one to one across countries. This requires that the data be collected in a comparable manner across countries with respect to data collection methods, measurement, and other criteria (Craig and Douglas 2005). In our data set, the PC subscription data seem to be sufficiently comparable between the U.S. and Japan to make inferences. As for the cellular phone subscription data, the Japanese data directly measure the Internet access subscription, since separate monthly access fee is required for the Internet service, e.g., NTT DoCoMo's highly successful and popular i-mode service. The U.S. data, on the other hand, reflect monthly charges for cellular phone service by wireless carriers such as Verizon Wireless, AT&T, Sprint, T-Mobile, among others, which are assumed to include voice communication, emails, and access to the Internet. Some carriers may impose additional one-time fee for extra service, however the dataset does not explicitly cover these costs.

In the following section, we present the estimation equations of the proposed model, estimation results, followed by the comparative analysis between the U.S. and Japan based on the estimation results, the temporal pattern analysis of segment sizes, and predictive validity of the model using the hold-out samples. We then present the theoretical perspective and empirical results with respect to the network externalities within the framework of Bass diffusion model.

Model Estimation

The proposed theoretical model in equations of (1) and (2) can be canonically expressed as the set of nonlinear equations, where each equation shares the common parameters in respective equations. By adding the error terms to theoretical model, we derive the econometric model for country k as follows:

$$(12) \quad \begin{cases} S_{kP}(t) = f_{kP}(t | \theta_k) + \varepsilon_{kP}(t) \\ S_{kC}(t) = f_{kC}(t | \theta_k) + \varepsilon_{kC}(t) \end{cases}$$

where θ_k denotes the vector of parameters for $k=US, Japan$, formally defined as

$$\theta_k = (\theta_k^{Initial}, \theta_k^{Conditional}, \theta_k^m)', \text{ where } \theta_k^{Initial} = (p_{kPC}^{Initial}, q_{kPC}^{Initial}, p_{kCell}^{Initial}, q_{kCell}^{Initial})'$$

$$\theta_k^{Conditional} = (p_{kPC}^{Conditional}, q_{kPC}^{Conditional}, p_{kCell}^{Conditional}, q_{kCell}^{Conditional})' \text{ and}$$

$\theta_k^m = (m_k^{PC}, m_k^{Cell}, m_k^{Cell-PC}, m_k^{PC-Cell})'$. We assume independent normal distributions on the error terms $\varepsilon_{kP}(t)$ and $\varepsilon_{kC}(t)$.

The prior distribution is set for parameters after logit transformations for p, q with zero-one restriction and log transformation for m with positive restrictions, i.e.,

$$\theta_k^* = [\text{logit}(p_{kP}^{Initial}), \dots, \text{logit}(q_{kC}^{Conditional}); \log(m_k^{PC}), \dots, \log(m_k^{PC-Cell})]'$$

Then the standard random effect model $\theta_k^* \sim N(\bar{\theta}, V_\theta)$ is used for HB estimation. The data set includes a small number of observations (the U.S. data contain 7 observations for PC, 14 observations for Cell, respectively, while Japanese data include 8 for PC and 17 for cell, respectively) for the model with 12 parameters to be estimated. Thus, pooling data of two countries is a viable solution for obtaining stable estimates from the hierarchical Bayesian model. We rely on the effect of ‘‘borrowing the strength of power from neighbors,’’ an intrinsic nature of HB modeling.

The MCMC method under noninformative proper prior distributions is applied to estimate the posterior density of parameters. The specification of likelihood function and prior density are provided in Appendix A. The joint posterior density is evaluated by MCMC Metropolis-Hasting sampling algorithm by using WinBUGS. 100,000 samples are generated and first 60,000 samples are discarded as burn-in period to confirm the convergence.

Posterior Distribution

The posterior density of parameters in Figure 3 shows that the majority of posterior densities are skewed and fat or long tailed. Most of the mean and median estimates yield similar values, whereas a large deviance between mean and median occurs for some parameters. Thus we report the median estimates along with means for interpreting the estimation results in the following section.

[Insert Figure 3 about here]

What do Estimation Results Imply and Suggest?

Results summarized in Table 2 show the mean and median estimates along with the 95% confidence intervals for each parameters. (We note that “HPD-highest probability density- region” is correct in Bayesian terminology, however, we use “confidence interval” hereafter for convenience.) Coefficient p estimates range from the smallest value of 0.0014 for the initial PC subscription to the largest value of 0.097 for the initial cell subscription, both of these in Japan. These estimates are consistent with the meta-analysis results (Sultan, Farley, and Lehmann1990). The U.S. values show the smaller range varying from the smallest value of 0.0046 for the initial PC subscription to the largest value of 0.007 for the conditional cell subscription.

[Insert Table 2 about here]

Coefficient q estimates, larger values than p estimates, would be the major interest for understanding the dynamics of diffusion processes. The results show the largest estimate of 0.899 for the initial cell phone subscription in Japan, whereas the smallest of 0.523 for the initial PC subscription in the U.S.

Conditional Diffusion and the Learning and Time Effect Hypotheses

We expect that the *initial* subscription estimates of the q coefficient tend to be smaller than the *conditional* ones, based on the hypothesis that the learning effect would accelerate the adoption rate for the conditional adoption. The same phenomenon is expected due to the time effect, because newer and better technology with a lower cost would accelerate the adoption rate. This holds for PC subscription in the U.S. (0.523 for initial subscription < 0.734 for conditional subscription) and Japan (0.586 for initial subscription < 0.745 for conditional subscription). This does not hold for cellular phones either in U.S. (0.836 > 0.737) or in Japan (0.899 > 0.701). Thus, the same pattern emerges in both U.S. and Japan.

Product Effect

We further analyze q estimates from the perspective of the device employed for access to the Internet, i.e., diffusion rate of pc subscriptions versus cellular subscriptions. The hypothesis of this product effect is that the diffusion rate of pc subscription is expected to be slower than the cellular subscription. Primary rationale for this hypothesis is that the subscription by the new technology device tends to accelerate the diffusion rate. The estimation results are that this holds true for the U.S. where the range of PC subscriptions vary from 0.523 for initial subscription to 0.734 for conditional subscription is smaller than that of cellular subscription which varies from 0.836 for initial subscription to 0.737 for conditional subscription. Japan's initial subscription results support the hypothesis that pc subscription diffusion (0.586) is lower than the cellular

subscription diffusion (0.899). However, the conditional subscription results show much smaller difference where PC subscription diffusion rate (0.715) and cellular diffusion rate (0.701).

These very interesting and intriguing results may imply that the different results for PC and cell subscriptions could be related to the old versus new innovations. The diffusion process of the old technology tends to last longer with smaller q values as opposed to the shorter diffusion process of the newer technology with larger q values. Therefore seemingly contradictory results are not anomaly but very plausible outcome.

Implications

In summary, PC subscription is considered to be a traditional diffusion which is characterized as slow diffusion at the initial stage and accelerating diffusion which is represented by the higher conditional subscription rate. Cellular subscription, on the other hand, is more modern technology which often entails the fast initial diffusion. Due to its newness, the conditional cellular subscription rate could be mitigated after the explosive initial diffusion. Even though we have a very intriguing results emanated both from two countries and two innovations as an important findings, we must be cautious not stretching its implications too much. We need more cases to draw any generalizable results.

Country Effect and the Flattening Hypothesis

The flattening hypothesis as opposed to the lead-lag hypothesis implies that there is not much difference in diffusion process among countries, more subtle for the access by the newer generation device. The estimation results support the hypothesis where diffusion rates of pc subscription are very similar for initial and conditional subscriptions (U.S. (0.523-0.734) \approx Japan (0.586-0.745)). The difference of initial and conditional subscriptions between the U.S. and Japan is very small (0.211-0.159 = 0.052). Cellular subscription diffusion also shows a smaller

difference between the two countries. [US (0.836-0.737) \approx Japan (0.899-0.701), Δ (0.099-0.198) = 0.099].

In summary, the results support the flattening hypothesis.

Parameter m

The aggregate estimates for the U.S. and Japan (265980 and 135515 subscriptions, respectively) as shown in Figure 4 are plausible, considering the populations of these two countries (317 million and 127 million people, respectively). The penetration in the Japanese market is relatively higher. This seems to be consistent with the geophysical characteristics of these countries where the population density in Japan is vastly higher in the much smaller market than the U.S. market.

[Insert Figure 4 about here]

We analyze the results with respect to the specific segment estimates. The largest among four segments in the U.S. are two conditional segments. The conditional “PC -> Cell” segment is dominant, and adopters in this segment initiate their access to the Internet by PC, and later on, add the cellular access. The next large segment, another conditional “Cell ->PC” segment, shows the opposite sequence of adoption, the segment most likely corresponding to the younger generations who tend to start their access with their cell phones. These conditional segments dominate the independent segments of “Only PC” and “Only Cell”. Considering the subscribers’ desire for the ubiquitous access to the Internet from home, workplace, and outdoors, the emergence of these two conditional segments as the major ones in the market place is quite plausible.

The Japanese market shows somewhat different outcome. The largest segment is the independent PC subscribers segment (38245), followed by the conditional “Cell->PC” segment

(35660). The “PC->Cell” segment, the largest one in the U.S., turns out to be the smallest in Japan. According to the report compiled by the Japanese Government (Japan Tourism Agency 2011), the free Wi-Fi access in Japan needs an improvement for foreign tourists who have expressed the troubling experience with limited Wi-Fi access and the strict security protocol, compared with other developed countries. This turns out to be a major concern for Japan who will host the summer Olympic Games in 2020 expecting the surge of foreign travelers. Considering the Internet access environment unique to Japan, the emergence of the large independent PC segment is plausible, and may imply that traditional access by PC is still common. The conditional cell-PC segment, similar to the U.S., may correspond to the younger generation who started their access by their cell phones and add the PC access to achieve more ubiquitous access.

Temporal Dynamic Segment Shift

The subscribers consist of three segments, namely one independent and two ubiquitous segments, as illustrated in Figure 1. Estimation results in Table 2 provide market potentials for these segments. The model is capable of unfolding the temporal shift among the segments so that we can better understand, not just the composition of the segments, but gain valuable insights into dynamic shift, if any, among segments. The results are summarized in Figure 5 where each bar consists of an independent segment labeled “only” and two ubiquitous segments.

[Insert Figure 5 about here]

Overall plots clearly illustrate the diffusion processes of conditional ubiquitous subscribers over time for the U.S. and cell phone subscribers in Japan, and supporting the ubiquitous hypothesis in Table 1. For the Japanese PC subscribers, the independent and conditional ubiquitous segments appear to coexist over time.

Notable differences in the diffusion processes between PC and cellphone subscribers are evident in Figure 5, across U.S. and Japan. Diffusion processes of pc subscribers tend to be modest and slow, in comparison to the cellular diffusion which shows faster diffusion dominated by the ubiquitous segments. The temporal plots reconfirm the empirical findings that q values for cell subscribers are higher than those for pc subscribers as reported in Table 2. The results thus support the accelerating diffusion and learning effect hypothesis presented in the theoretical framework in Table 1.

The emergence of similar diffusion patterns within the device, but the lack of significant differences in the diffusion processes across countries, support the flattening hypothesis.

Model Validations

The proposed model is validated by conducting the following analyses: (1) comparison against alternative model formulation, (2) “in sample fit analysis” of the proposed model versus actual data, and (3) predictive performance and the advantage of the unconditional predictive density. Those analyses show that the proposed model outperforms the alternative model, and that the model has a very good fit to the data. We showcase that on top of the excellent predictive performance, the unconditional predictive density can provide more valuable information for forecasting than the traditional point estimates.

Model Comparison

The proposed ubiquitous HB model is compared against a nested HB model. The nested model uses the subscription data by a single device, either cell phone or PC, whereas the data used for the proposed model include both devices, thus the pooling for these models varies. The alternative model is labeled as the “non-ubiquitous HB model,” because subscription to the Internet relies upon a single device.

<i>Model</i>	<i>DIC</i>	<i>Log ML</i>
Ubiquitous HB	867.9	-447.8
Non-Ubiquitous HB	894.4	-453.2

The above results clearly indicate that the proposed model performs better than the alternative model based on two goodness fit of measures, commonly used for Bayesian modeling, the deviance information criteria (DIC) and the log of marginal likelihood (log ML). The proposed model shows the smaller DIC and the larger log ML values. In addition, the predictions by the ubiquitous HB model, as is discussed soon below, perform significantly better than other comparable models.

In Sample Fit

An overall fit of the proposed model is very well as illustrated in Figure 6 where the actual data is indicated in red while the predicted mean values indicated as a bar in the inter quarter range box plot. The majority of predicted values lie within 95% confidence interval which is shown as an outer range around the box plot, except for just three cases (US-PC, obs. 7 and 14, and Japan-cellphone, obs. 10). It is notable that the proposed HB model can provide more reliable information for its prediction by generating the posterior density around the estimated values, on top of the traditional point estimates. The posterior density distribution via interpolation was constructed by using the algorithm for s-step predictive density with *the negative predictive step* ($s \leq 0$), i.e., *retrospective prediction*, as is shown in the following section.

[Insert Figure 6 about here]

Predictive Validity

The advantageous feature of using Bayesian approach is that we can obtain the predictive density, and that forecasting with uncertainty can be expressed with predictive interval, in

comparison to the econometric approach which usually only provides the point forecast. This is important for marketing managers who need to make decisions under uncertainty, because they can foresee the distribution around the forecast. The predictive density has been introduced in the early period of modern Bayesian inference (cf. Zellner 1970, pp.29-30), and the recent application includes the study by Terui and Ban (2013). Neelamegham and Chintagunta (1999) applied predictive distribution to the diffusion study of new movies viewership forecast by using the generalized linear model. Their model is static and therefore the predictive density is conditional upon the possible scenarios for future covariates. Our dynamic model, on the other hand, generates the unconditional predictive density as explained below.

The unconditional predictive density The predictive density for s-step ahead forecast is formally defined as

$$(13) \quad p(Y_{T+s} | \text{Data}) = \int p(Y_{T+s} | \theta) p(\theta | \text{Data}) d\theta$$

where Y_{T+s} stands for s step ahead forecast of dependent variable and θ means the parameter vector. The integration in (13) can be numerically evaluated by efficient Monte Carlo methods, i.e., by generating samples $Y_{T+s}^{(i)}$ in addition to MCMC iterations for posterior density

$p(\theta | \text{Data})$. The algorithm in detail is described in Appendix B. For diffusion models with an explanatory variable of “time”, the structural equation $p(Y_{T+s}^{(i)} | \theta^{(i)})$ is easily updated by shifting T to $T+s$, without assuming scenarios for future explanatory variables. Moreover, we can evaluate the joint predictive density for consecutive predictors $p(Y_{T+s}, Y_{T+s^*} | \text{Data})$, and this allows us to makes joint predictive interval when necessary.

Based on the predictive density, we could state with 95% confidence that the numbers of PC subscribers in both countries in the period of $T+k$ will fall within the predictive interval.

Figure 7 shows the predictive density of two step ahead forecasting for respective products in both countries. The 95% predictive interval is provided at the bottom of each graph in 7. We observe that most predictive densities are well defined, and predictive intervals contain the actual holdout samples for all the cases.

[Insert **Figure 7** about here]

The predictive interval is constructed based on finite number of sample. The counterpart is possible in case of maximum likelihood estimation by using asymptotic theory, which assumes that large number of samples are available. Obviously, it would not work well, if the number of observations is limited, and if the model is highly nonlinear, like ours.

The root mean squared errors (RMSE) of forecast are provided in Table 3. The proposed Bass model has the smallest RMSE marginally in most cases, and it has smaller total RMSE value than other models, including the ubiquitous model estimated by nonlinear LS(least squares) method

[Insert Table 3 about here]

Network Effects

We measure the direct network externalities following the study by Nagard-Assayag and Manceau (2001) in which their indirect network externality model is specified as the number of users of a product at time t, S(t), based on a binary logit framework as follows:

$$(14) \quad S(t) = m \frac{1}{1 + \exp(-U(t))},$$

where U(t) is the utility that a consumer derives from subscription. In order to measure the direct network externality, we specify U(t) as:

$$(15) \quad U(t) = \alpha + \beta S(t-1),$$

where $S(t-1)$ is the lagged number of subscribers, or the network size, α is to capture the network independent, or the “stand-alone” utility of the subscription, and β measures the direct network effects. The formulation and its variants of Equation 14 have been widely employed in the theoretical and empirical studies (e.g., Katz and Shapiro 1992; Goolsbee and Klenow 2002; Padmanabhan, Rajiv, and Srinivasan 1997) to operationalize to measure the direct network effects where a positive estimate of β would indicate the network externality.

Estimation results employing the HB estimation summarized in Table 4 show that the direct network externalities are present for the diffusion of PC and cellular subscriptions in the U.S. and Japan, since estimates of $\beta_{PC, US}$ and $\beta_{Cell, US}$, $\beta_{PC, JPN}$, and $\beta_{Cell, JPN}$ are positive and significant. Thus, digital convergence as discussed in the theoretical framework and summarized in Table 1 is evident.

[Table 4 about here]

Two more significant results call for further analysis within the theoretical framework. First, the empirical results show that cellular subscription exhibits the stronger network externality than PC subscription. This confirms the existence of the accelerating diffusion and support of the learning effect hypothesis. More importantly, stronger network effect emanated from the cellular subscription is in concordance with higher conditional adoption by the ubiquitous segment as conjectured in the theoretical framework (1.3). Second, Japan exhibits higher level of the network externality than the U.S. This may be attributable to the substantial difference in the macro environment, such as geographic environment in which Japan is a high density country with very limited land area which is roughly equivalent to the state of Montana, and this consequently contributes to a much higher level of physical proximity among subscribers.

Conclusions

The major theme of this study is to study the diffusion processes of the ubiquitous IT innovation. The empirical results appear to support the majority of hypotheses as summarized in Table 1. We organize this section into three sections. First, we review contributions of this study to diffusion research, specifically three areas of contributions, namely, theoretical, methodological, and empirical contributions. Second, we discuss managerial contributions to be derived from empirical findings. Third, we conclude this section by reviewing limitations of this study, and directions for future studies.

First, we attempt to highlight theoretical contributions to the diffusion research emanated from the formulation of the comprehensive ubiquitous diffusion model. The basic Bass model under the homogenous market assumption is not appropriate for grasping the highly complex diffusion mechanism of the ubiquitous diffusion. First, the realization of the existence of heterogeneous market segments defined by the sequential adoption processes of innovation is necessary to properly account for the heterogeneous diffusion processes. Our modeling approach could be characterized as a bottom-up process, starting from building the segment specific diffusion models and aggregating the models across segments, in contrast to a top-down approach which may start with formulating a single equation model and add extra parameters to account for heterogeneity. We chose the former strategy because diffusion process of the ubiquitous segments involve far more complex mechanism, and cannot be explained by merely throwing in extra parameters. Second, the objective of developing the conditional diffusion model was to properly represent the adoption process within the ubiquitous segment. Third, the ubiquitous nature of IT innovation requires more comprehensive and recursive model than the

successive substitution model by Norton and Bass (1987), and the simultaneous recursive model is developed.

Methodological contributions are associated with the formulation of hierarchical Bayesian estimation model of simultaneous econometric equations. We showcase the effective use of posterior density around the parameter estimates, which can provide the predictions with more reliable information than the traditional point estimates. Analysis of the predictive density is still at infancy in diffusion research, in spite that studies in econometric time series analysis demonstrate the utility of predictive density, and that marketing studies, even though limited, show its usefulness (Neelanmegham and Chintagunta 1999). Our study illustrates that the predictive density is valuable information for managers, since they are eager to assess future sales potential. Needless to state, the HB estimation for diffusion research is proven to be more than efficient and effected than the traditional econometric modeling of the Bass model due to the limited data available for estimation.

The empirical findings indicate that the ubiquitous segments are significant, in particular for cellular subscribers segments for both the U.S. and Japan. This lends support for the validity of the ubiquitous diffusion model and the conditional diffusion processes. Further, the quite similar diffusion processes are emerging in both countries, which supports the flattening hypothesis. As summarized in Table 1, the accelerating diffusion effect is evident, and the learning effect hypothesis is supported. An existence of the network effect is confirmed, and a large magnitude of its effect is in concordance with the ubiquitous segment hypothesis and the accelerating hypothesis. In summary, it appears to be fair to state that theoretical testing with the empirical evidence of this study yields the plausible results.

Managerial implications derived from the empirical results are as follows: First, managers need to properly understand the complex diffusion processes of heterogeneous markets. Relying on the homogeneous assumption and using the single equation diffusion model leads to misleading understanding of the market place. This calls for a comprehensive modeling and accurate data. Second, managers need to understand the dynamic interactive behavior of the ubiquitous subscribers who employ various devices in a variety of sequences to gain access to the Internet. Third, potential market size for separate segments derived from the proposed model provides managers with capability to assess sales potentials for each segment. Properly understanding and assessing the importance and significance of the ubiquitous segment is vital for determining the target segment and formulating the marketing strategy.

There are some limitations of this study. We used data on digital cellular phone subscribers in the U.S., considering them as the good approximation of Internet users via cellular phone. However, the U.S. data may be inflated because digital cellular phone subscribers include not only cellular phone Internet users but also regular talk only users. It is desirable to have the data which can isolate the Internet subscription from other functions.

As for future studies are concerned, for better generalization, we need to accumulate empirical evidence by applying the proposed model to data on other countries. Second, to further examine the model performance, the proposed model needs to be applied to data on other innovations.

In summary, the demand for ubiquitous access is expected to accelerate further in the future, and we are already observing such evidence with the added capability of the Internet access to a wide variety of devices, such as game machines (Nintendo Wii), Apple Touch, and HDTVs. The gaining popularity of large screen smartphones and mini tables such as mini iPad and Android

tables are expected to further accelerate the diffusion of ubiquitous access to the Internet. We believe that the proposed model can be expanded to cope with these future developments.

REFERENCES

- Bass, Frank M. (1969), "A New Product Growth Model for Consumer Durables," *Management Science*, 15 (January) 215-227.
- _____ (1995), "Empirical Generalization and Marketing Science: A Personal View," *Marketing Science*, 14 (3), 6-19.
- Craig, Samuel and Susan P. Douglas (2005), *International Marketing Research*, Third Edition, Chichester, UK: John Wiley and Sons.
- Ehrenberg, A. S. C. (1995), "Empirical Generalizations, Theory, and Method," *Marketing Science*, 14 (3), 20-28.
- Friedman, Thomas (2006), *The World is Flat*, Updated and expanded edition, New York: Farrar, Straus and Giroux.
- Gatignon, Hubert, Jehoshua Eliashberg, and Thomas S. Robinson (1989), "Modeling Multinational Diffusion Patterns: An Efficient Methodology," *Marketing Science*, Volume 8, Issue 3, 231-247.
- Geweke, J. and N. Terui (1993), "Bayesian Threshold Autoregressive Models for Nonlinear Time Series", *Journal of Time Series Analysis*, 14 (5), 441-454.
- Goldenberg, Jacob, Barak Libai, and Eitan Muller (2010), "The Chilling Effects of Network Externalities," *International Journal of Research in Marketing*, 27, 4-15.
- Goolsbee, Austan and Peter J. Klenow (2002), "Evidence on Learning and Network Externalities in the Diffusion of Home Computers," *Journal of Law and Economics*, 45 (October), 317-343.
- Japan Tourism Agency (2011), *Report on the Survey Results for Foreign Travelers*, Ministry of

- Land, Infrastructure, Transport and Tourism, The Government of Japan, November 1, 1-18.
- Katz, Michael L. and Carl Shapiro (1985), "Network Externalities, Competition, and Compatibility," *American Economic Review*, 75 (3), 424-40.
- _____ and _____ (1992), "Product Introduction with Network Externalities," *Journal of Industrial Economics*, 40 (1), 55-83.
- Kim, Namwoon, Dae Ryun Chang, and Allan D. Shocker (2000), "Modeling Intercategory and Generational Dynamics for a Growing Information Technology Industry," *Management Science*, 46 (April), 496-512.
- Lee, Jonathan, Peter Boatwright, and Wagner Kamakura (2003), "A Bayesian Model for Prelaunch Sales Forecasting of Recorded Music," *Management Science*, Vol. 49, No. 2 (February), 179-196.
- Levitt, Theodore (1983), "The Globalization of Markets," *Harvard Business Review*, May-June, 1-10
- Muller, Eitan (2014), "Chapter 4. Innovation Diffusion," *The History of Marketing Science: World Scientific – Now Publishers Series in Business: Vol. 3*, edited by Russell S Winer and Scott A Neslin, Hackensack, NJ: World Scientific Publishing Company/NOW.
- Nagard-Assayag, Emmanuelle Le and Delphine Manceau (2001), "Modeling the Impact of Product Preannouncements in the Context of Indirect Network Externalities," *International Journal of Research in Marketing*; 18 (September), 203-219.
- Neelamegham, R and P. Chintagunta (1999), "A Bayesian Model to Forecast New Product Performance in Domestic and International Markets," *Marketing Science*, vol.18, 115-136.
- Norton, John A. and Frank M. Bass (1987), "A Diffusion Theory Model of Adoption and

- Substitution for Successive Generations of High Technology Products,” *Management Science*, 33 (September), 1069-1086.
- Padmanabhan, V., Surendra Rajiv, and Kannan Srinivasan (1997), “New Products, Upgrades, and New Releases: A Rationale for Sequential Product Introduction,” *Journal of Marketing Research*, 34 (November), 457-472.
- Peres, Renana, Eitan Muller, and Vijay Mahajan (2010), “Innovation Diffusion and New Product Growth Models: A Critical Review and Research Directions,” *International Journal of Research in Marketing*, 27, 91-106.
- Peterson, Robert A. and Vijay Mahajan (1978), “Multi-Product Growth Models,” *Research in Marketing*, 1, Jagdish Sheth (ed.), Greenwich: JAI Press Inc., 201–231.
- Putsis, William P., Sridhar Balasubramanian, and Subrata K. Sen (1997), “Mixing Behavior in Cross-Country Diffusion,” *Marketing Science*, November 1, 354-369
- Putsis, P. William, Jr. and V. Srinivasan (2000), “Estimation Techniques for Macro Diffusion Models,” in *New Product Diffusion Models*, Vijay Mahajan, Eitan Muller, and Jerry Wind (eds.), Boston: Kluwer Academic Publishers, 263–291.
- Rogers, Everett M. (2003), *Diffusion of Innovations*, Fifth Edition, New York, NY: Free Press.
- Rohlfis, Jeffrey (1974), “Econometric Analysis of Supply in Concentrated Markets,” *International Economic Review*, 15 (February), 69-74.
- Stremersh, Stefan, D. R. Lehmann, and M. G. Dekimpe (2010), “Preface to the Chilling Effects of Network Externalities”, *International Journal of Research in Marketing*, 27, 1-3.

- Sultan, Fareena, John U. Farley, and Donald R. Lehmann (1990), "A Meta-Analysis of Applications of Diffusion Models," *Journal of Marketing Research*, Vol. 27, No. 1 (February), 70-77.
- Talkadar, D., K. Sudhir, and A. Ainslie (2002), "Investigating New Product Diffusion across Products and Countries," *Marketing Science*, Vol. 21, No.1, 97-114.
- Terui, N. and M. Ban (2014), "Multivariate Structural Time Series Models with Hierarchical Structure for Over-dispersed Discrete Outcome," 33, *Journal of Forecasting*, 376-390.
- Wind, Yoram, Thomas S. Robertson, and Cynthia Fraser (1982), "Industrial Product Diffusion by Market Segment," *Industrial Marketing Management*, 11 (February), 1-8.
- Zellner, A. (1970), *Introduction to Bayesian Inference in Econometrics*, Wiley.

Table 1
Theoretical and Modeling Framework and Empirical Results

	Theoretical constructs and hypotheses	Previous studies	Empirical results	Implications
1	Consumer heterogeneity and market segmentation H1. The ubiquitous market segment hypothesis	The majority of studies use the homogeneous assumption with single market segment*	Heterogeneous market segment model is developed. H1. The dominant segment is the ubiquitous segment.	The diffusion model under the heterogeneous market assumption is necessary to properly identify and measure the diffusion processes of varying market segments.
2	Successive and more Comprehensive model.	Successive substitution model (Norton and Bass 1987)	Subscribers using newer generation of devices also adopt older devices.	Both directions of old-new innovation adoptions need to be incorporated in the model.
3	The conditional diffusion model	None for ubiquitous diffusion, and the majority of studies are limited to non-ubiquitous diffusion of the initial adoption model	Ubiquitous adoption is evident. Non-ubiquitous diffusion is prevalent for PC subscription, while ubiquitous conditional adoption is more prevalent for cell subscription.	The comprehensive model for both ubiquitous and non-ubiquitous diffusion is required. Old generation service follows the traditional diffusion pattern, while new generation service follows a more complex diffusion pattern.
4	Accelerating diffusion H2. The learning effect hypothesis	International diffusion research confirms the accelerating and learning effect.	Accelerating diffusion occurs for cell subscription. H2. The learning effect hypothesis is supported for PC subscription.	Younger segments tend to adopt the new generation devices faster, and without much effort to learn.
5	Cross-country research H3. The flattening hypothesis	International diffusion research found the lead and lag effect.	Cellular subscriptions show homogeneous diffusion pattern. H3. Supported	The standardized strategy may fit for diffusion of the cellular subscriptions across different countries.
6	Network externalities H4. The direct network externalities	Extensively studied	The direct network externalities exist for the data. H4. Supported.	Digital convergence is evident.

Table 2
Estimation Results

		<i>US</i>					<i>Japan</i>				
		Parameters	Mean	Median	95% CI Lower Upper		Parameters	Mean	Median	95% CI Lower Upper	
<i>p</i>	PC	$p_{US,PC}^{ini}$.0048	.0046	.0017	.0094	$p_{JP,PC}^{ini}$.0021	.0014	.0001	.0088
		$p_{US,PC}^{cond}$.0178	.0057	.0001	.1088	$p_{JP,PC}^{cond}$.0188	.0066	.0002	.1214
	Cell	$p_{US,Cell}^{ini}$.0074	.0065	.0019	.0174	$p_{JP,Cell}^{ini}$.0990	.0968	.0608	.1505
		$p_{US,Cell}^{cond}$.0096	.0070	.0001	.0376	$p_{JP,Cell}^{cond}$.0201	.0053	.0002	.1489
<i>q</i>	PC	$q_{US,PC}^{ini}$.531	.523	.406	.710	$q_{JP,PC}^{ini}$.593	.586	.347	.889
		$q_{US,PC}^{cond}$.696	.734	.202	.979	$q_{JP,PC}^{cond}$.706	.745	.212	.978
	Cell	$q_{US,Cell}^{ini}$.792	.836	.408	.986	$q_{JP,Cell}^{ini}$.873	.899	.627	.989
		$q_{US,Cell}^{cond}$.712	.737	.302	.979	$q_{JP,Cell}^{cond}$.666	.701	.179	.975
<i>m</i>	PC	m_{US}^{PC}	53026	45275	4273	142205	m_{JP}^{PC}	38615	38245	6458	74860
	Cell	m_{US}^{Cell}	51848	46405	5535	124300	m_{JP}^{Cell}	35208	34410	5350	70860
	PC-Cell	$m_{US}^{PC-Cell}$	113040	116000	22517	183303	$m_{JP}^{PC-Cell}$	29963	27200	5293	68321
	Cell-PC	$m_{US}^{Cell-PC}$	61207	58300	7255	131600	$m_{JP}^{Cell-PC}$	36492	35660	5645	71881
<i>Common</i>		\bar{p}	0.009	0.007	16370	80161					
		\bar{q}	0.73	0.742	0.0010	0.0291					
		\bar{m}	41415	39025	0.458	0.936					
<i>Market potential</i>		PC ^a	227273				PC ^a	105070			
		Cell ^b	226095				Cell ^b	101663			

a: The potential market size for PC is calculated as $m^{PC} + m^{PC-Cell} + m^{Cell-PC}$.

b: The potential market size for cellular phone is calculated as $m^{Cell} + m^{Cell-PC} + m^{PC-Cell}$.

Table 3
Root Mean Squared Errors of Forecast

<i>Forecast Period</i>	<i>Model</i>	<i>US, PC</i>	<i>US, Cell</i>	<i>Japan, PC</i>	<i>Japan, Cell</i>	<i>Total</i>
1 Step Ahead	Ubiquitous HB	7793	8495	244	1293	5801
	Non-Ubiquitous HB	8463	10735	687	4486	7202
	Nonlinear LS	8467	11199	325	4366	7353
2 Steps Ahead	Ubiquitous HB	5020	8373	916	1005	4928
	Non-Ubiquitous HB	5334	13237	1324	4861	7567
	Nonlinear LS	5349	14320	356	4692	7997

Table 4
Network Effect

<i>Parameters</i>	<i>PC</i>			<i>Cell</i>		
	<i>Mean</i>	<i>Median</i>	<i>SD</i>	<i>Mean</i>	<i>Median</i>	<i>SD</i>
<i>U.S.</i>						
α	-2.478	-2.462	0.213	-2.459	-2.412	0.37
β	0.04	0.039	0.005	0.065	0.064	0.016
m	160482	159900	8710	130953	130000	9153
<i>Japan</i>						
α	-2.9	-2.82	0.605	-2.532	-2.396	0.937
β	0.14	0.132	0.046	0.462	0.428	0.352
m	62113	61650	5988	69314	67070	10707

Figure 1
Ubiquitous Model and Market Segments

Segmentation

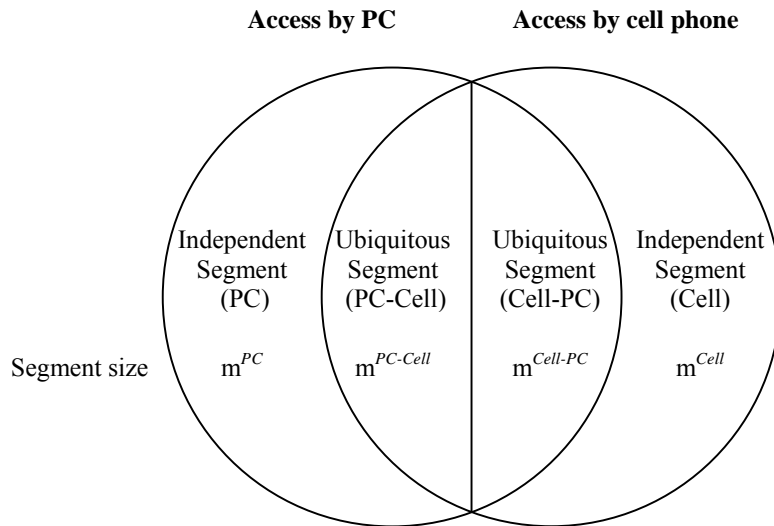

Model for subscription by PC

$$S_P(t) = \underbrace{S_P^{PC}(t) + S_P^{PC-Cell}(t)}_{\text{Initial subscription}} + \underbrace{S_P^{Cell-PC}(t)}_{\text{Conditional subscription}}$$

Model for subscription by cell phone

$$S_C(t) = \underbrace{S_C^{Cell}(t) + S_C^{Cell-PC}(t)}_{\text{Initial subscription}} + \underbrace{S_C^{PC-Cell}(t)}_{\text{Conditional subscription}}$$

Figure 2
Initial and Conditional Adoption Processes

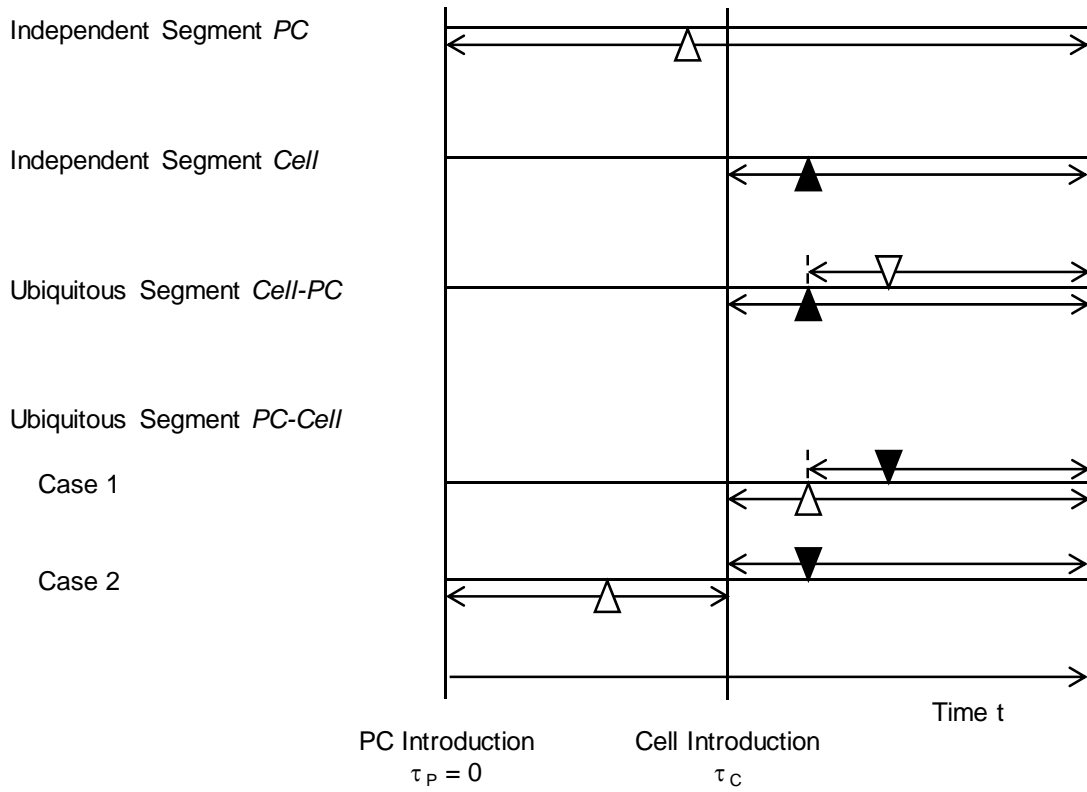

- | | |
|--|--|
| \triangle Initial PC Adoption | ∇ Conditional PC Adoption |
| \blacktriangle Initial Cell Adoption | \blacktriangledown Conditional Cell Adoption |

Figure 3
Posterior Distribution of Parameters

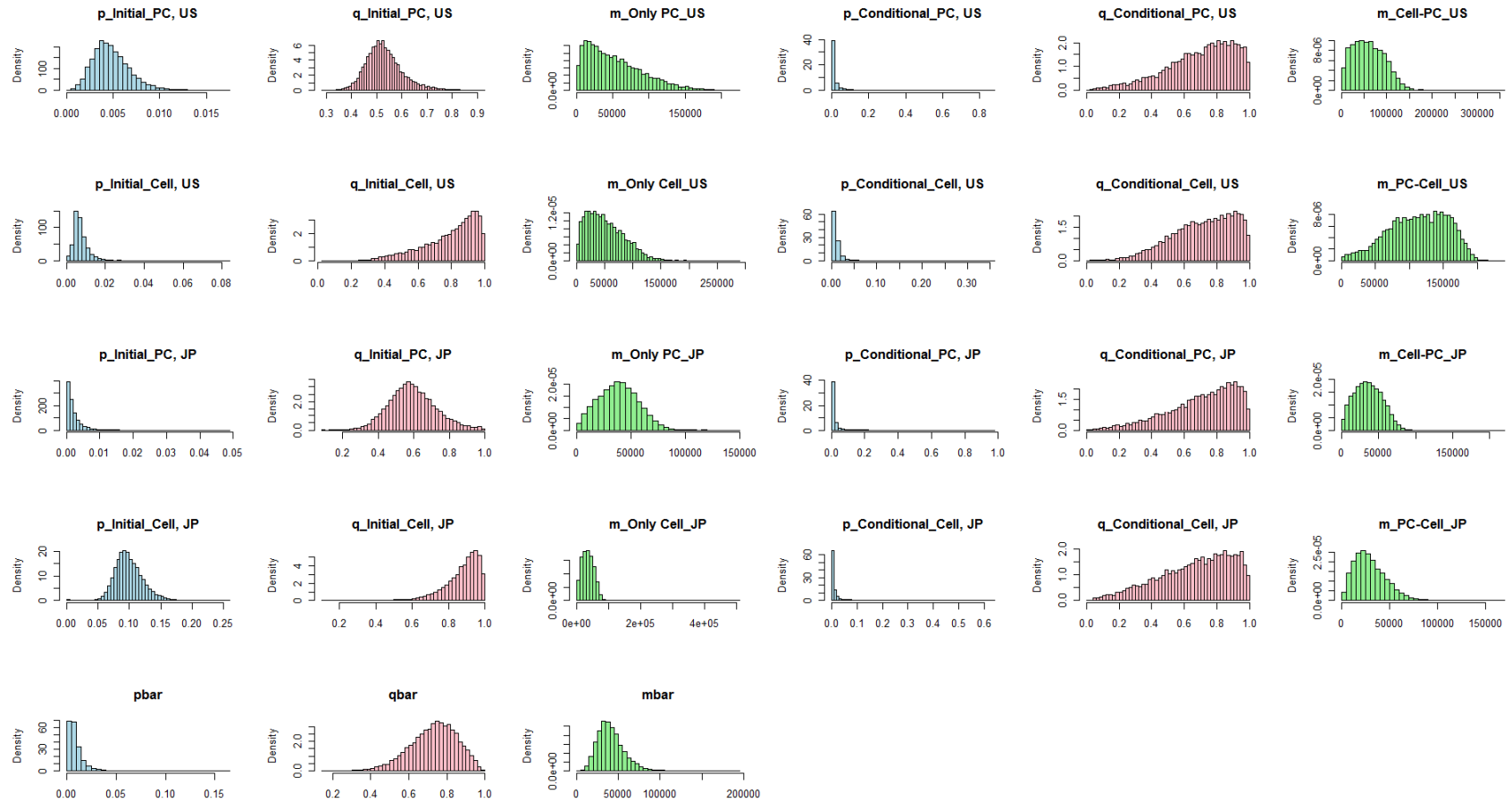

Figure 4
Estimated Market Potential

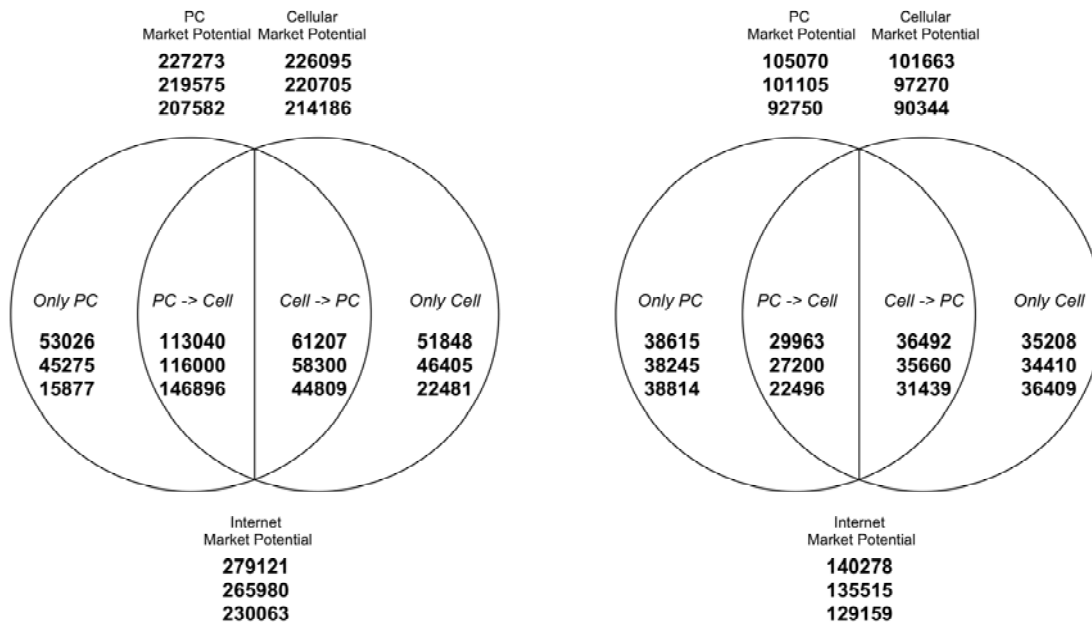

Figure 5
New Subscribers Within Each Segment

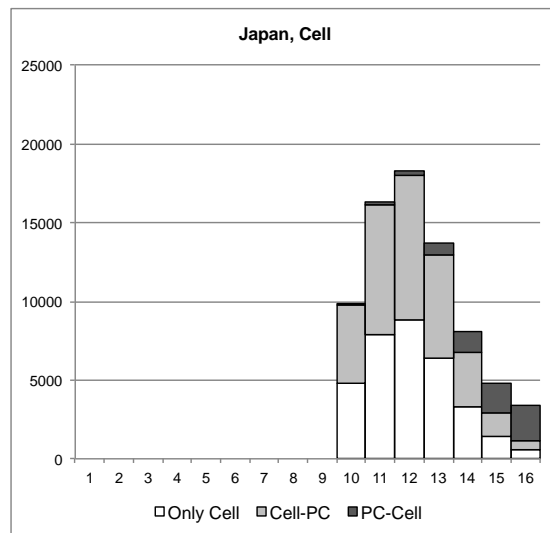
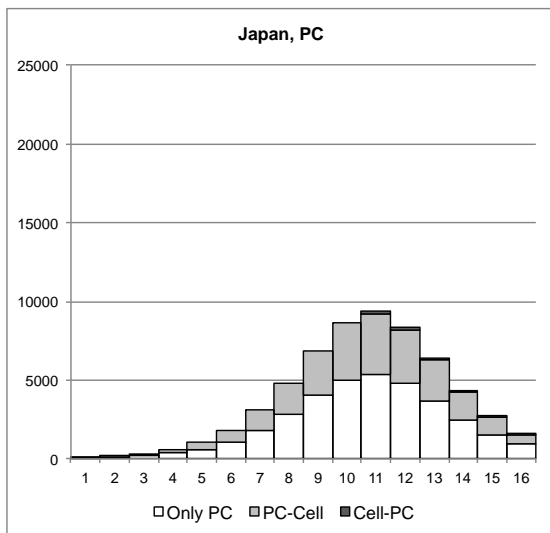
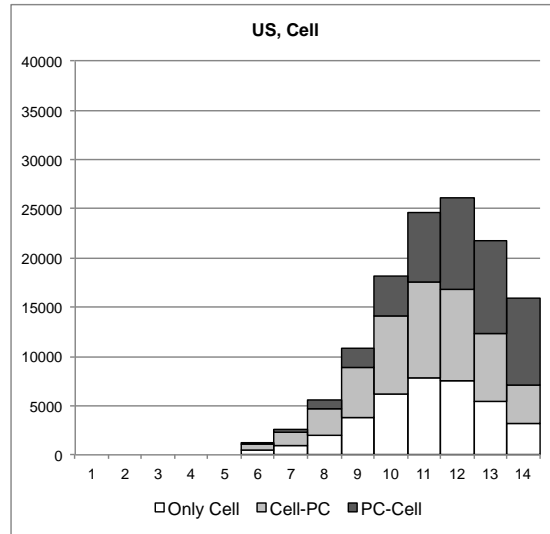
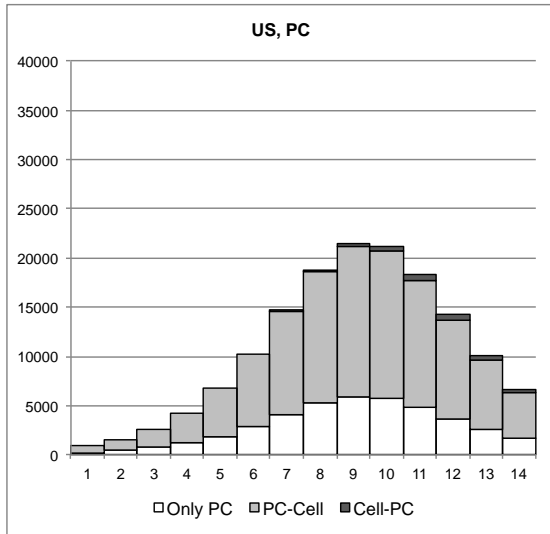

Figure 6
In Sample Fit:
Actual vs. Predicted

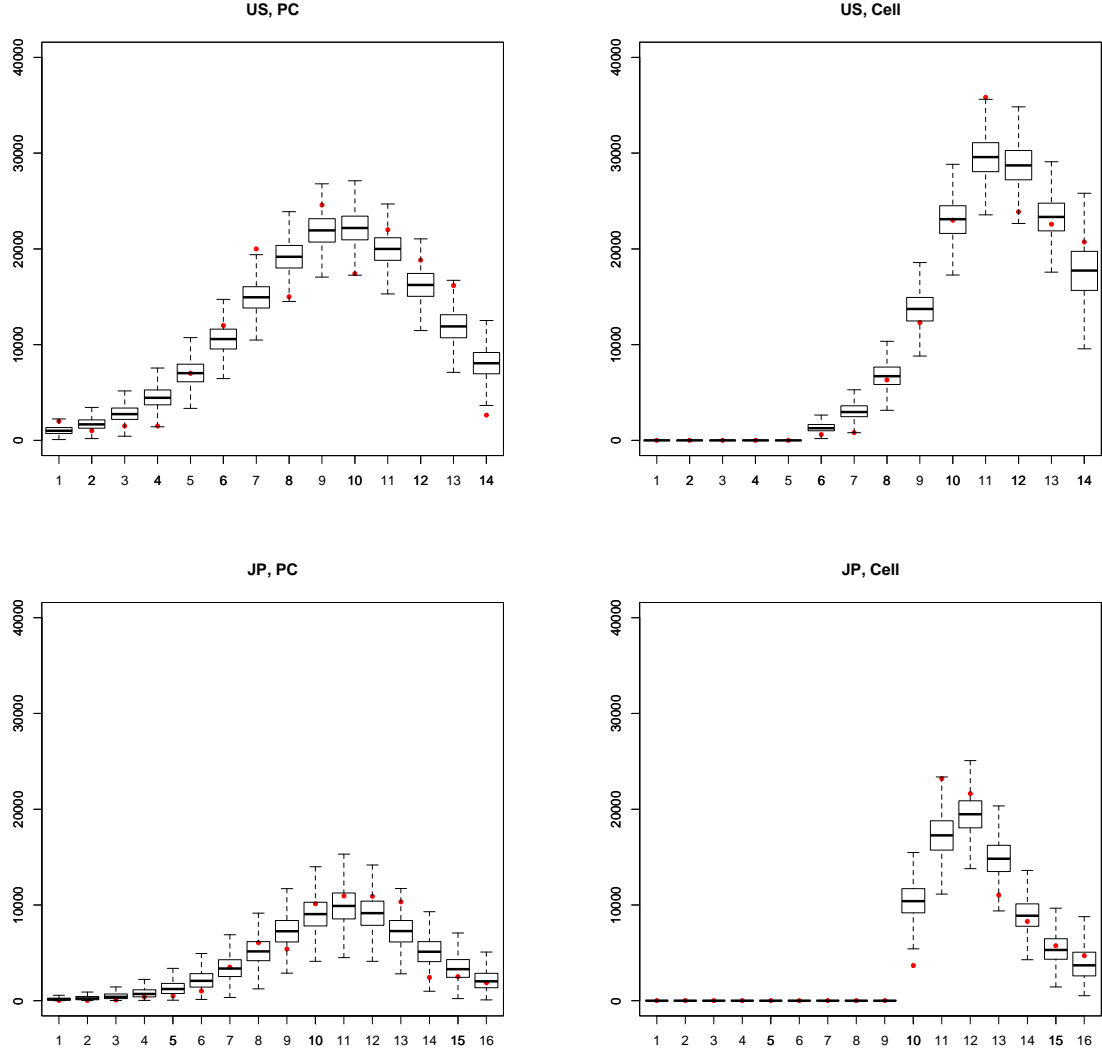
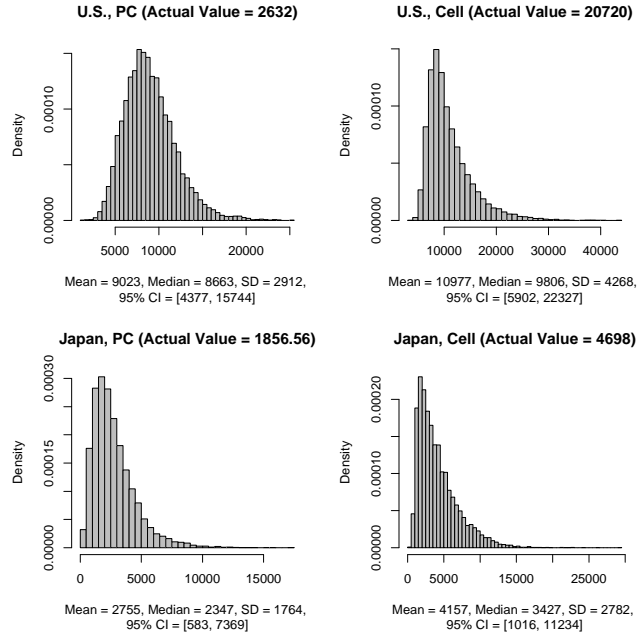
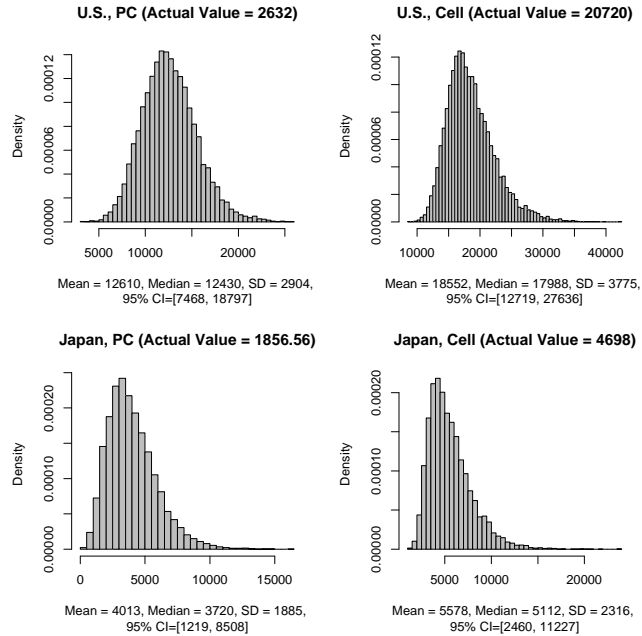

Figure 7 Predictive Density: Two-Steps Ahead

Subscribers at time period T



Subscribers at time period T - 1



Appendix: The MCMC Algorithms

A: Joint Posterior Density

Under the assumption of independent normal distribution on the error terms $\varepsilon_{kP}(t)$ and $\varepsilon_{kC}(t)$, we have the Gaussian joint likelihoods from the equation (E1)

$$(A1) \quad p\left(\{S_{kr}(t)\}, \{t\} \mid \{\theta_k\}\right) \propto \prod_{k=US}^{Japan} \prod_{r=PC}^{Cell} \sigma_{kr}^{-T_{kr}/2} \exp\left\{-\frac{1}{2} \sum_{t=1}^{T_{kr}} \left(S_{kr}(t) - f_{kr}(t \mid \theta_k)\right)^2 / \sigma_{kr}^2\right\}$$

where θ^k denotes the vector of parameters in the equation (E1) for $k=US, Japan$, and $r=P, C$. The

prior distribution is set for parameters after logit transformations for p, q with zero-one restriction and log transformation for m with positive restrictions, i.e.,

$$\theta_k^* = \left[\text{logit}\left(p_{kP}^{Initial}\right), \dots, \text{logit}\left(q_{kC}^{Conditional}\right); \log\left(m_k^{PC}\right), \dots, \log\left(m_k^{PC-Cell}\right) \right].$$

Then we employ the standard random effect model $\theta_k^* \sim N(\bar{\theta}, V_\theta)$ and this is combined with the likelihood function (E2), with adjusted by appropriate Jacobians to get the joint posterior density

$$p\left(\{\theta_k\} \mid \{S_{kr}(t)\}, \{t\}\right). \text{ The hyper-parameters are set as noninformative } \bar{\theta} \sim N(0, 100 \times I),$$

$V_\theta \sim IW(\nu, \nu \times I)$ and $\nu = \dim(\theta_k) + 3$. We also set the diffuse prior on the error variance as

$$\sigma_{kr}^2 \sim IG(.001, .001).$$

B: Predictive Density

The algorithm for predictive density follows:

- (i) generate a sample $\theta^{(i)} \square p(\theta \mid \text{Data})$
- (ii) conditional on $\theta^{(i)}$, we make $Y_{T+s}^{(i)}$ according to the structural equation $p\left(Y_{T+s}^{(i)} \mid \theta^{(i)}\right)$ in (13).
- (iii) This process is iterated many times to get $\left\{Y_{T+s}^{(i)}, i = 1, \dots, M\right\}$.

Then the empirical distribution of it converges to the predictive density $p(Y_{T+s} | \text{Data})$ as M goes to infinity.

We note that the structural equation $p(Y_{T+s}^{(i)} | \theta^{(i)})$ is easily updated simply by shifting T to $T+s$, not assuming scenarios for future explanatory variables. In addition, we can evaluate the joint predictive density for consecutive predictors $p(Y_{T+s}, Y_{T+s}^* | \text{Data})$ by evaluating

$$\left\{ \left(Y_{T+s}^{(i)}, Y_{T+s}^{*(i)} \right), i = 1, \dots, M \right\}.$$