

# A Nuclear Structure Study of Doubly Odd Nuclei $^{154}\text{Tb}$ and $^{156}\text{Ho}$

著者	Itoh Y., Hayashibe S., Kikuchi M., Miyatake H., Ishimatsu T.
journal or publication title	CYRIC annual report
volume	1980
page range	83-88
year	1980
URL	<a href="http://hdl.handle.net/10097/48573">http://hdl.handle.net/10097/48573</a>

V. 11 A Nuclear Structure Study of Doubly Odd Nuclei  $^{154}\text{Tb}$  and  $^{156}\text{Ho}$

Itoh Y., Hayashibe S., Kikuchi M., Miyatake H. and Ishimatsu T.  
Department of Physics, Faculty of Science, Tohoku University

It has been reported recently that  $N=89$  doubly-odd nucleus  $^{152}\text{Eu}$  in the shape transitional region shows a well-behaved ground state rotational band,<sup>1)</sup> and the level scheme has been interpreted in terms of the Nilsson model.<sup>2)</sup> It is therefore interesting to study the nuclear structure of neighboring doubly-odd  $N=89$  isotones,  $^{154}\text{Tb}$  and  $^{156}\text{Ho}$ .

We measured  $\gamma$ -rays emitted from an enriched  $^{152}\text{Eu}_2\text{O}_3$  target irradiated with  $\alpha$ -particles and those from a  $^{159}\text{Tb}$  target irradiated with  $^3\text{He}$ -particles. Higher energy  $\gamma$ -rays were measured with a  $40\text{ cm}^3$  Ge(Li) and a  $76\text{ cm}^3$  Ge(HP) detector, and lower energy  $\gamma$ -rays with a  $0.7\text{-cm}^3$  Ge(HP) and a  $5\text{-cm}^3$  Ge(HP) detector. Spectra of  $\gamma$ -rays emitted from the  $^{153}\text{Eu}_2\text{O}_3$  target irradiated with 40 MeV  $\alpha$ -particles are shown in Figs. 1 and 2; in Fig. 1 is shown a singles spectrum measured with the  $0.7\text{ cm}^3$  Ge(HP) detector, and in Fig. 2 a coincidence spectrum measured with the large volume Ge(HP) detector which was gated on the 192.8 keV  $\gamma$ -ray detected with the  $5\text{ cm}^3$  Ge(HP) detector. The  $\gamma$ -rays from the  $^{153}\text{Eu}(\alpha, 3n\gamma)^{154}\text{Tb}$  and  $^{159}\text{Tb}(\text{}^3\text{He}, 6n\gamma)^{156}\text{Ho}$  reactions were identified from excitation functions and  $\gamma$ - $\gamma$  coincidence relations. Angular distributions of these  $\gamma$ -rays were also measured.

The data of the present experiment suggest the existence of band structures in  $^{154}\text{Tb}$  and  $^{156}\text{Ho}$ ; four bands in  $^{154}\text{Tb}$  and one in  $^{156}\text{Ho}$ . Fig. 3 shows the four proposed bands in  $^{154}\text{Tb}$ . Since no interrelation between the four level groups has been found in the present experiment, the relative energies of the levels in each group are given in keV. The relative spins are also given which have been estimated from the angular distributions of  $\gamma$ -rays. As is seen in Fig. 3, these bands are classified into two categories: 1) the bands shown in figs. 3a and 3b depopulate via E2 cross-over transitions as well as  $M1+E2$  cascade transitions, both types of transitions being of comparable intensity; 2) the bands shown in Figs. 3c and 3d depopulate via strong  $M1+E2$  cascade and weak E2 cross-over transitions. It is noticed that the feature of the former category is similar to that of the bands in transitional odd-A nuclei strongly mixed by the Coriolis interaction. The band observed in  $^{156}\text{Ho}$  belongs to the former category.

#### References

- 1) Lanier R. G., Struble G. L., Mann L. G., Proctor I. D. and Heikkinen D. W., Phys. Lett. 78B (1978) 217.
- 2) von Egidy T., et al., Z. Phys. A286 (1978) 341.

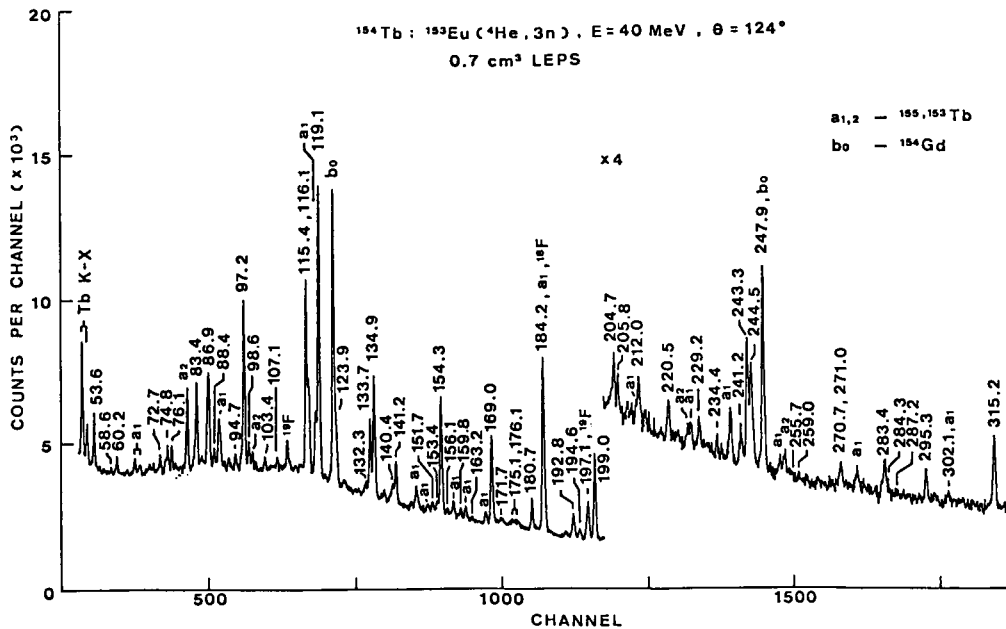

Fig. 1. A singles  $\gamma$ -ray spectrum from an enriched  $^{152}\text{Eu}_2\text{O}_3$  target irradiated with 40 MeV  $\alpha$ -particles. It was measured at  $124^\circ$  with a  $0.7 \text{ cm}^3$  Ge(HP) detector. To the peaks identified with the transitions in  $^{154}\text{Tb}$  are attached the numerical figures which represent peak energies in keV. The notations  $a_1$  and  $a_2$  indicate the peaks identified with the transitions in  $^{153}\text{Tb}$  and  $^{155}\text{Tb}$ , respectively, and  $b$  indicates the peaks identified with the transitions in  $^{154}\text{Gd}$  following the EC decay of  $^{154}\text{Tb}$ .

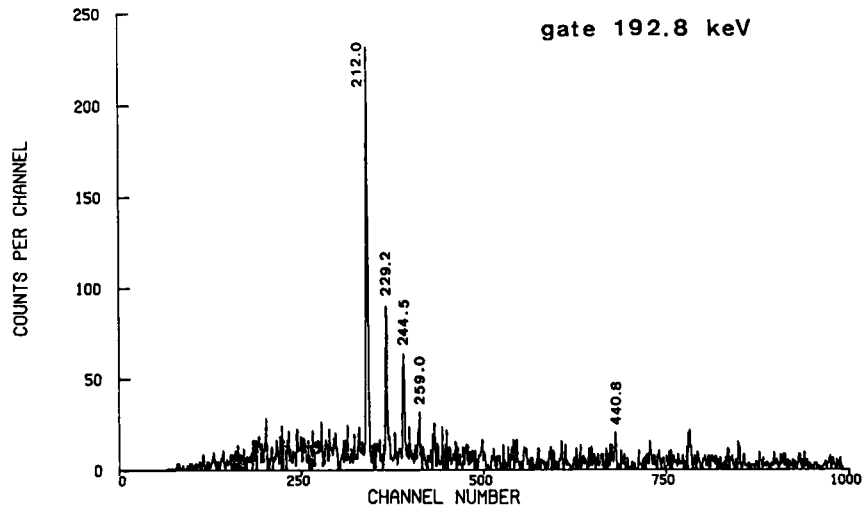

Fig. 2. A  $\gamma$ - $\gamma$  coincidence spectrum measured with a  $76 \text{ cm}^3$  Ge(HP) detector which was gated on the 192.8 keV  $\gamma$ -ray detected with a  $5 \text{ cm}^3$  Ge(HP) detector.

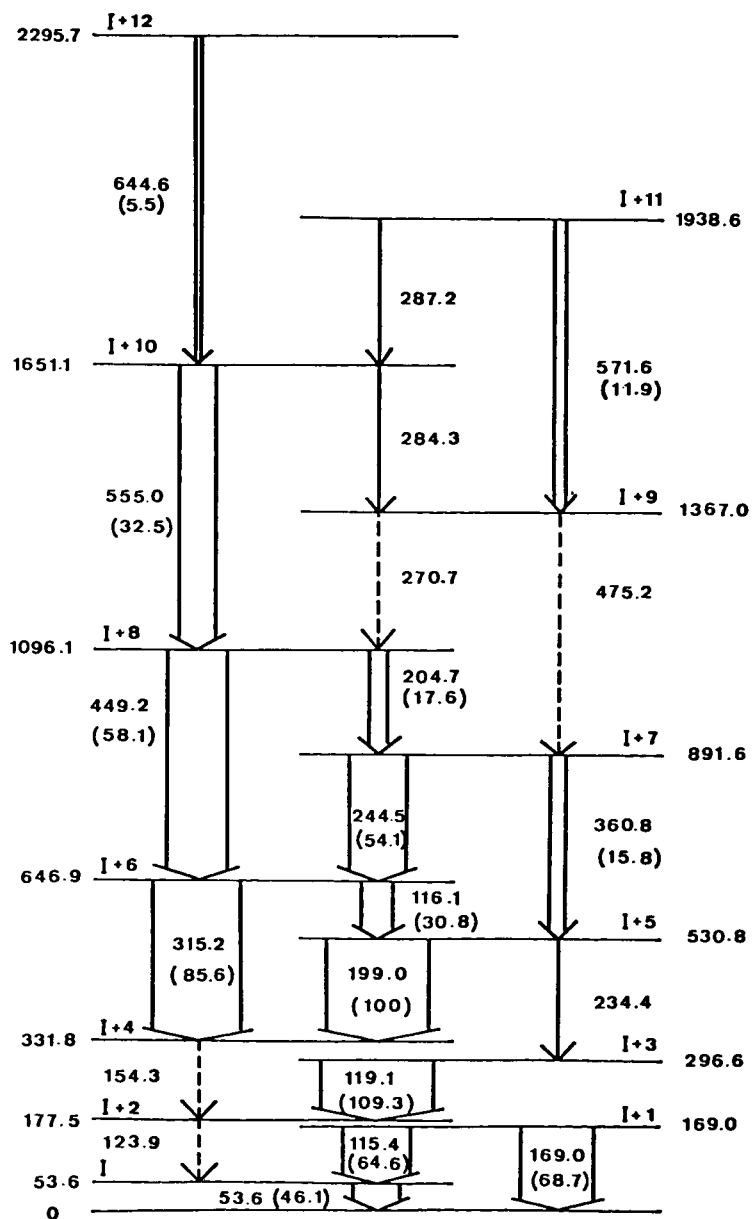

Fig. 3a. Decay schemes of  $^{154}\text{Tb}$  proposed in the present study. No interrelation between these four groups of levels were found. Transition energies and relative level energies are given in keV. The numerical figures in parentheses are relative  $\gamma$ -ray intensities. The widths of the transition arrows are proportional to the  $\gamma$ -ray intensities. The dashed arrows represent the transitions of which the relative  $\gamma$ -ray intensities were not determined because of the presence of unresolved interfering lines.

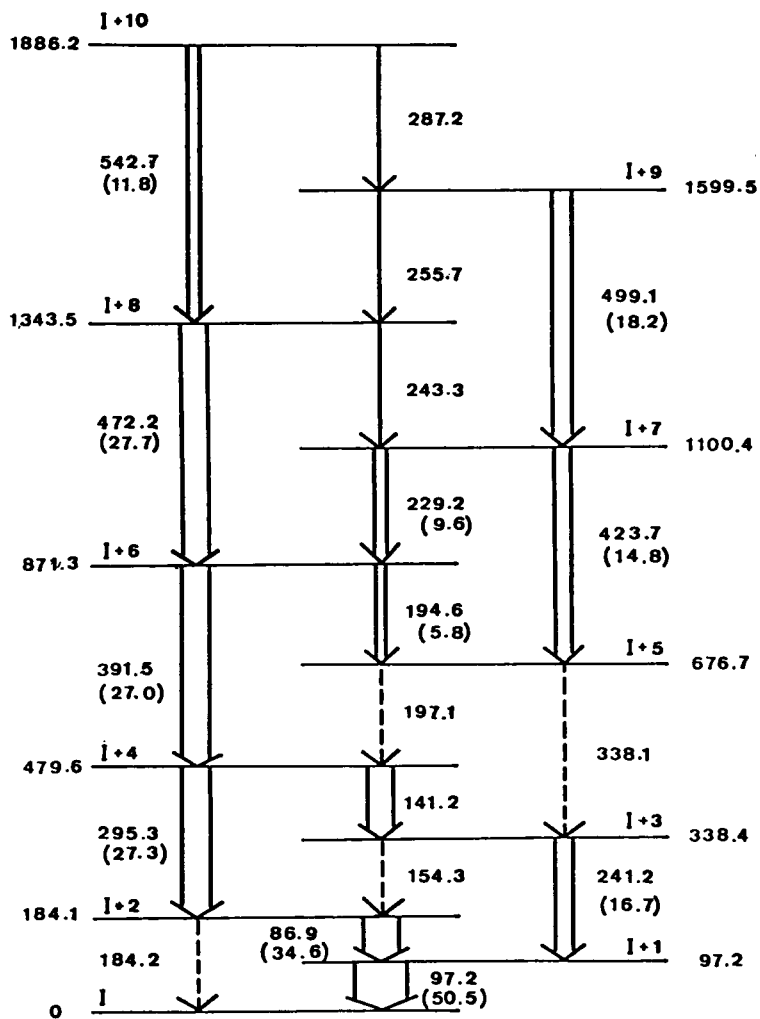

Fig. 3b. See caption of fig. 3a.

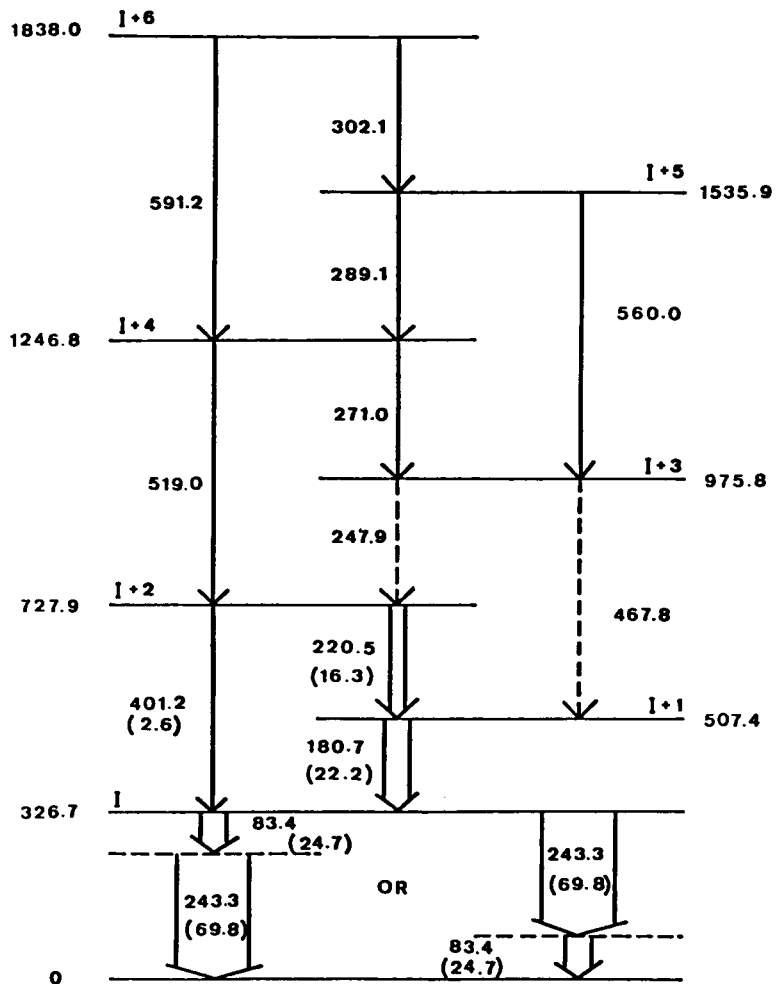

Fig. 3c. See caption of fig. 3a.

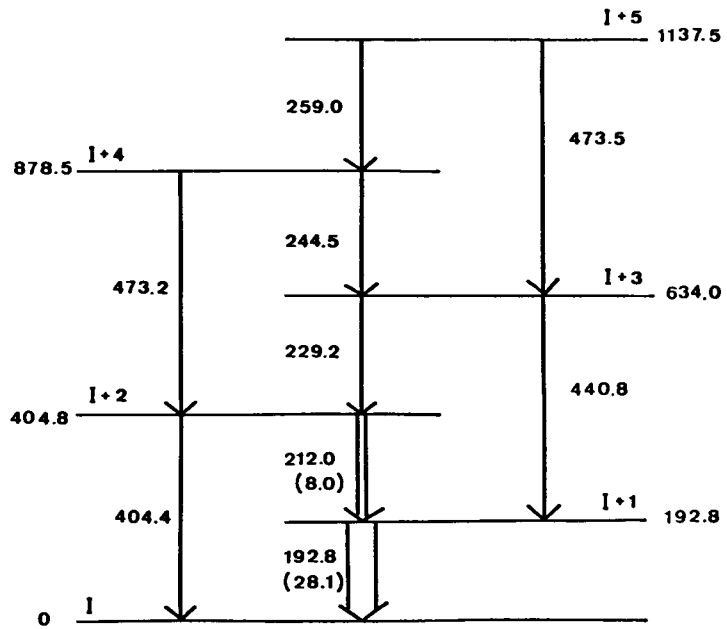

Fig. 3d. See caption of fig. 3a.