

Compact Glow Discharge X-Ray Tube

著者	Tsuji Kouichi, Wagatsuma Kazuaki
journal or publication title	Review of Scientific Instruments
volume	69
number	11
page range	4006-4007
year	1998
URL	http://hdl.handle.net/10097/53368

doi: 10.1063/1.1149213

Compact glow discharge x-ray tube

Kouichi Tsuji^{a)} and Kazuaki Wagatsuma
*Institute for Materials Research, Tohoku University, 2-1-1 Katahira,
Aoba-ku Sendai Miyagi 980-8577, Japan*

(Received 30 June 1998; accepted for publication 21 August 1998)

We have developed a compact glow discharge x-ray tube (diameter: 10 mm, length: 20 mm), which is composed of a hollow anode tube, a cathode plate, and a thin film target. This glow discharge device was operated with an Al thin film target at a discharge voltage of 2.0 kV at a discharge current of 0.1 mA and at a He pressure of approximately 0.2 Torr, which was used as the discharge gas. The characteristic x rays of Al $K\alpha$ are produced by bombardment of electrons emitted from the cathode surface. The strong x-ray emission intensity, which depended on the operating voltage and the gas pressure, was obtained throughout the discharge time of 1.5 h. © 1998 American Institute of Physics. [S0034-6748(98)03811-8]

An x-ray emission tube is an indispensable piece of equipment for various analytical methods. The x-ray tube is usually composed of a target and a filament.¹ When thermo-electrons emitted from the heated filament impinge on the target, x rays are produced. A high vacuum is maintained inside of the x-ray tube in order to increase the lifetime and high stability of the filament. A gas x-ray tube was used in the initial stages of the study of x rays.^{2,3} The residual gas in the tube was utilized as the discharge gas and it was difficult to keep the gas pressure constant at that time; therefore, it was gradually phased out. However, a Grimm-type glow discharge tube,⁴ developed in 1967, is very stable and has been utilized as an optical emission source and an ion source for the direct analysis of solid samples. These methods are known as glow discharge optical emission spectroscopy⁵ and glow discharge mass spectroscopy.⁶ In these methods, the glow discharges are operated at voltages of 500–1000 V, at currents of 30–100 mA, and at Ar pressures of 0.1–10 Torr. These discharge conditions are suitable for cathode sputtering by Ar ions as well as for the excitation and ionization of atoms in the plasma.

We have studied glow discharges with applied high voltages of up to 10 kV by measuring the x rays.^{7–9} When a voltage of several kV is applied, electrons emitted from the cathode surface by ion impact are accelerated by the electric field of the cathode sheath and impinge on a target, leading to x-ray emission. We have called this x-ray emission source a glow discharge x-ray tube (GDXT).⁹ The merits of the GDXT are its simple construction, easy maintenance, exchangeable targets, and low cost. The development of compact analytical instruments is of great importance. In this note, we report on the merits of a compact GDXT developed for its simple construction.

Figure 1 shows a schematic drawing of the compact GDXT. The anode tube (inner diameter: 4 mm, length: 20 mm) is made of brass and has a gas inlet tube and a vacuum tube. When the inner diameter of the anode tube was less

than 2 mm, the glow discharge would be unstable. An Al plate (diameter: 10 mm) was used as the cathode. An Al thin film (thickness: 0.05 mm, diameter: 3 mm) used as the target was glued on the Al plate and was attached to the anode tube on the opposite side of the cathode. A sputtering phenomenon occurs on the cathode surface during the discharge.¹⁰ A large fraction of the sputtered atoms are deposited on the inner wall of the anode tube and the target. Since the type of x rays produced depends on the kind of target material, contamination on the target is a significant problem for the x-ray emission source. This problem can be solved by using a cathode made from the same material as the target. Therefore, we used an Al cathode for the Al target in this work. The outer surface of the anode tube was covered with a polytetrafluoroethylene (PTFE) tube to prevent intermittent discharges between the cathode and the outer surface of the anode tube. By using this PTFE protector, a stable glow discharge could be sustained inside the anode tube.

After the inside of the GDXT was evacuated by a rotary pump, He gas was introduced at a pressure of 0.15 Torr, which was monitored with a Pirani gauge. Then, a negative high voltage was applied to the cathode in a constant-voltage mode by a high-voltage power supply (EW 10R60; Glassman High Voltage, USA). X rays emitted from the Al thin film were detected by a Si(Li) solid state x-ray detector (EMAX; Horiba Co., Japan), and were energy analyzed by a multichannel analyzer (MCA/PC98-B; Laboratory Equipment Co., Japan). The distance between the x-ray detector and the Al thin film was approximately 15 mm.

A typical x-ray spectrum measured is shown in Fig. 2. The GDXT was operated at a voltage of 2 kV; a discharge current of 0.1 mA; and a He pressure of 0.15 Torr. The strong characteristic x rays of Al $K\alpha$ were detected against a low background intensity. The x-ray intensity depends on the relationship between the discharge voltage, current, and the gas pressure.¹⁰ Therefore, if the discharge current increases along with increasing the gas pressure, then the electrons bombarding the target would also increase, thus yielding higher x-ray intensities. However, this furious electron bombardment leads to the destruction of the thin film target, be-

^{a)}Corresponding author; electronic mail: tsuji@imr.tohoku.ac.jp

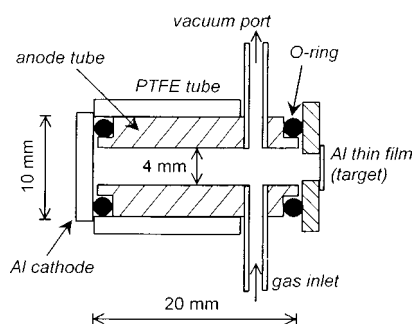

FIG. 1. Schematic drawing of the compact glow discharge x-ray tube. This discharge tube was evacuated by a rotary pump, then He gas was introduced. A negative high voltage was applied to the cathode.

cause the target is only air cooled. To prevent this, our compact GDXT was operated under the moderate discharge conditions of 2 kV, 0.1 mA, and 0.15 Torr. Figure 3 shows the time dependence of the x-ray emission intensity of Al $K\alpha$. The x-ray intensity gradually decreased with the discharge time. As the discharge progressed, the temperature of the GDXT rose, and cathode sputtering occurred. As these changes progressed, the discharge current gradually decreased with the discharge time, leading to the decrease of the x-ray emission intensity.

In conclusion, we custom-made a compact and simple GDXT with an Al thin film target. A strong Al $K\alpha$ x-ray emission was obtained throughout the discharge time of 1.5 h. The GDXT lifetime was not investigated in this work; however, it would take several hours. When the discharge

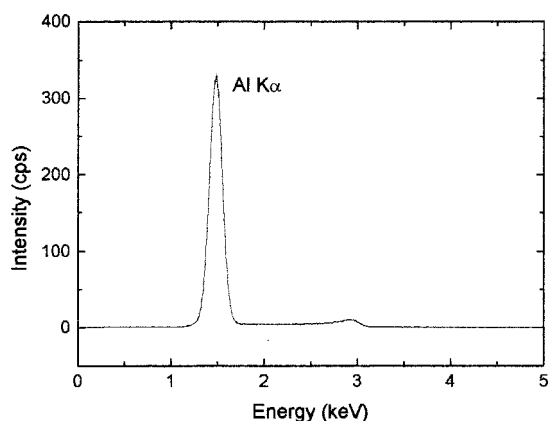

FIG. 2. Typical x-ray spectrum emitted from the Al thin film target. The GDXT was operated at a voltage of 2 kV at a current of 0.1 mA and a He pressure of 0.15 Torr.

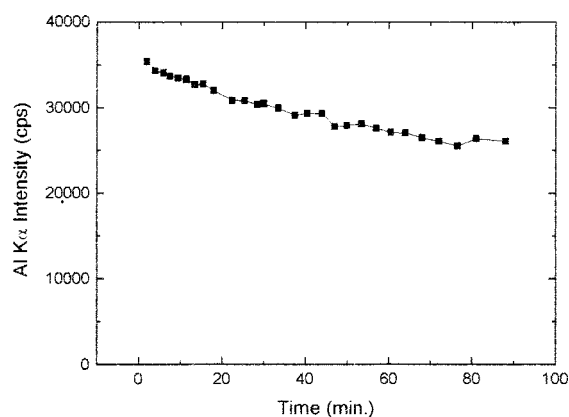

FIG. 3. Time dependence of the x-ray intensity of Al $K\alpha$. The GDXT was operated at a voltage of 2 kV and a He pressure of 0.26 Torr. The area intensity of the Al $K\alpha$ peak was measured.

becomes unstable, it is needed to clean the anode tube. This maintenance is easy because the GDXT construction is simple. Moreover, since the cathode and the target are both exchangeable, an x-ray emission of different energies can easily be obtained. For example, when an Fe thin film target and an Fe cathode are used, the x-ray emission of Fe $K\alpha$ is obtained. Moreover, it would be possible to develop a gas sealed-type shorter GDXT.

Part of this work was supported by a Grant-in-Aid for Encouragement of Young Scientists (A) (09750805) from the Ministry of Education, Science, Sports and Culture of Japan. The authors thank Mr. S. Shucart for valuable suggestions.

- ¹R. E. Van Grieken and A. A. Markowicz, *Handbook of X-Ray Spectrometry* (Dekker, New York, 1993).
- ²B. D. Cullity, *Elements of X-Ray Diffraction* (Addison-Wesley, Reading, MA, 1956).
- ³R. W. M. D'eye and E. Wait, *X-Ray Powder Photography in Inorganic Chemistry* (Butterworths, London, 1960).
- ⁴W. Grimm, *Naturwissenschaften* **54**, 586 (1967).
- ⁵R. Payling, *Glow Discharge Optical Emission Spectrometry* (Wiley, New York, 1997).
- ⁶W. W. Harrison, K. R. Hess, R. K. Marcus, and F. L. King, *Anal. Chem.* **58**, 341A (1986).
- ⁷K. Tsuji, H. Matsuta, and K. Wagatsuma, *Jpn. J. Appl. Phys., Part 2* **36**, L446 (1997).
- ⁸K. Tsuji, K. Wagatsuma, and H. Matsuta, *Spectrochim. Acta B* **52**, 1587 (1997).
- ⁹K. Tsuji, T. Sato, and K. Wagatsuma, *Spectrochim. Acta B* **53**, 417 (1998).
- ¹⁰P. W. J. M. Boumans, *Anal. Chem.* **44**, 1219 (1972).