

Substance Flow Analysis of Indium for Flat Panel Displays in Japan

著者	Nakajima Kenichi, Yokoyama Kazuyo, Nakano Kazuko, Nagasaka Tetsuya
journal or publication title	Materials Transactions
volume	48
number	9
page range	2365-2369
year	2007
URL	http://hdl.handle.net/10097/52001

Substance Flow Analysis of Indium for Flat Panel Displays in Japan

Kenichi Nakajima¹, Kazuyo Yokoyama¹, Kazuko Nakano² and Tetsuya Nagasaka¹

¹Graduate School of Environmental Studies, Tohoku University, Sendai 980-8579, Japan

²Organization for Research and Development of Innovative Science and Technology (ORDIST), Kansai University, Suita 564-8680, Japan

Substance flow analysis (SFA) of indium has been conducted in this study. The purpose of this study is to identify the relevant issues for the development of an efficient indium recycling system by performing SFA of indium supplied for indium-tin oxide (ITO) processing as transparent electrodes, which accounts for 86.9% of the total indium demand. In this study, as part of the development of substance and material flow data, (1) data on the flow of indium was collected and reviewed, (2) the amount of dissipated indium associated with the production of flat-panel displays (FPDs) were estimated and (3) its environmental impact was also assessed.

The major conclusions are (a) 470 t-In is used in ITO for transparent electrodes, out of which 220 t-In is dissipated or potentially dissipated in Japan, and (b) 220 t-In of dissipated indium is equivalent to 11.4 TJ of energy consumption, 0.5×10^3 t of CO₂ emissions, and 1.0×10^6 t of Total Materials Requirement (TMR). [[doi:10.2320/matertrans.MAW200702](https://doi.org/10.2320/matertrans.MAW200702)]

(Received April 9, 2007; Accepted June 13, 2007; Published August 1, 2007)

Keywords: Material flow analysis, Substance flow analysis, Indium, Indium tin oxide, recycle

1. Introduction

Japan is almost entirely dependent on imports of minerals and non-ferrous metals such as rare metals, securing a stable supply of such natural resources is of paramount importance to Japan. Rare metals are essential raw materials for “manufacturing industries” in Japan, which produce high-quality and high value-added products. A secure supply of rare metals is vital for developing Japan’s industries.

With such background, national stockpiling programs for rare metals are maintained to secure a stable supply of these resources and to prevent any major social or economic problems that may result from supply shortages in Japan. At present, seven kinds of elements (Ni, Cr, W, Co, Mo, Mn, and V) are stockpiled.¹⁾ In addition, seven other metals—Pt, Nb, Sr, rare earth metals (REs), Ta, Ga, and In—are currently identified as requiring consideration for future national stockpiling.

However, the information on supply and demand of rare metals, which are essential for developing material recycling systems and resource strategies, are very limited extent in The Ministry of Economy, Trade and Industry (METI)’s statistics.²⁾ In order to compensate for the lack of information, material/substance flow analyses (MFAs/SFAs) are actively performed at the Japan Oil, Gas and Metals National Corporation (JOGMEC), the Rare Metal Association (RMA), universities, and research institutions.^{3–5)} MFA/SFA is attracting international attention as a tool for identifying and controlling substance flows. The history and development of MFA is described by Brunner.⁶⁾ Gradel and his co-workers have proposed a new MFA technique,^{7,8)} and the Wuppertal Institute has estimated resource flows associated with the use of materials.⁹⁾ In this study, as part of the development of substance and material flow data, we have developed data on and analyzed the material flow of indium.

Indium (In) is a metal with a concentration of 0.049 ppm in the earth’s crust and is produced as a byproduct of zinc, lead, and tin extraction processes. The sources and established industrial processes of indium were reviewed by Alfantazi

and Moskalyk.¹⁰⁾ Indium is a functional material used mainly in indium-tin oxide (ITO) films for producing transparent electrodes. In recent years, its demand is rapidly increasing.

Ranked 66th in elemental abundance in the earth’s crust, indium is classified as a very rare metal.¹¹⁾ Therefore, it is one of the elements requiring efficient use. Previously, the world’s largest indium mining was done at the Toyoha mine in Hokkaido, Japan, with a production of approximately 70 t/year. However, the mine stopped operation at the end of March in 2006. As a result, no indium is currently produced in domestic mines, and it is exclusively produced in Japan as a byproduct of the extraction process of imported zinc ore. According to data from the U.S. Geological Survey (USGS), the recoverable reserves of indium are 2,800 t-In and the confirmed reserves are 6,000 t-In.¹²⁾

The New Energy and Industrial Technology Development Organization (NEDO) in Japan has forecasted the supply and demand for indium.¹³⁾ According to NEDO’s report, a scenario analysis shows that the resources of indium may be depleted by between 2011 and 2013 on a recoverable reserve basis (2,800 t-In) and by 2019 on a confirmed reserve basis (6,000 t-In).

The purpose of this study is to identify the relevant issues for developing an efficient indium recycling system by performing an SFA of indium supplied for in ITO processing for transparent electrodes, which accounts for 86.9% of the total indium demand. In this study, as part of the development of substance and material flow data, (1) data on the flow of indium was developed, (2) the amount of dissipated indium associated with the production of flat-panel displays (FPDs) were estimated and (3) its environmental impact was also assessed.

2. Review of Indium Flow in Japan

The issues relevant to this study were identified by examining data on (a) the supply and demand for indium and (b) the existing material flow. Data on the supply and demand for indium in Japan are available from “Industrial

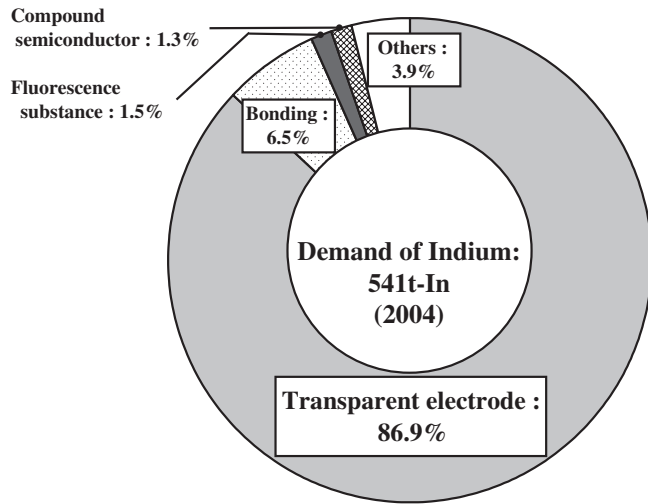

Fig. 1 Demand of indium in Japan (2004).

Rare Metals”,¹⁴⁾ while data on country-specific indium imports are available from JOGMEC’s report.¹⁵⁾ Data on the macro-material flow of indium in Japan are also available from JOGMEC’s report.¹⁶⁾

Figure 1 shows the sector-specific demand for indium in Japan. It is observed that 86.9% of the total domestic demand for indium was supplied for ITO processing for transparent electrodes. ITO films are used in FPD products such as LCD (liquid crystal display) TV and PDP (plasma display panel) TV.

Figure 2 shows the change in the supply and demand for indium in Japan and the change in the percentage of imported indium resources (imported indium/indium supply). In Fig. 2, indium produced from imported ore (zinc ore, lead ore, and tin ore) is summed up to domestic indium. In recent years, there has been a drastic increase in the supply and demand for indium in Japan due to the widespread use of FPD products. As a result, indium imports from China are increasing, and that accounted for approximately 70% of the

total indium imports in 2004. As a result of the closing of the Toyoha mine in 2006, domestic indium production is predicted to reduce drastically. In this context, it is an important issue to secure the domestic indium resources by promoting recycling. In Fig. 2, the difference in supply amount and demand amount is increasing. It seems that the cause of this difference is change of stock in the maker of target material.

Figure 3 shows an indium material flow chart produced using JOGMEC’s report.¹⁶⁾ In Fig. 3 JOGMEC estimated the amount of the net change of stock, which is shown “Δ stock”, by the difference in supply and demand of indium. The supply of indium resources and the sector-specific demand for indium can be obtained from the chart. However, the biggest limitation of this chart is that (i) the scrap flow and (ii) the amount of indium in the final products, which are required to identify the relevant issues for recycling indium, are not known.

3. Substance Flow Analysis of Indium in Japan

3.1 Estimation of Indium Flow Chart

Indium is used in various products in the form of ITO films, which are sputtered onto a surface of substrates. The yield of indium in the sputtering process is available from Nishida’s report.¹⁷⁾ The indium flow was estimated using data from the literature. Table 1 shows the basis for the estimation of the indium flow. The material flow of indium evaluated in the present investigation is represented in Fig. 4, in which net change of indium stock (Δ stock) is estimated by difference of supply and demand of indium based on JOGMEC’s method.

The literature¹⁷⁾ shows that the utilization of indium in the FPD processing is approximately 3%; 70% is recovered as target residual material, reduced to indium metal, and reused; the remaining 20% is spread on the surface of tools and devices; 5% is loosed in photo etching process; and 2% is used in faulty panels. The demand for indium in ITO for transparent electrodes is 470 t-In; however, the amount of

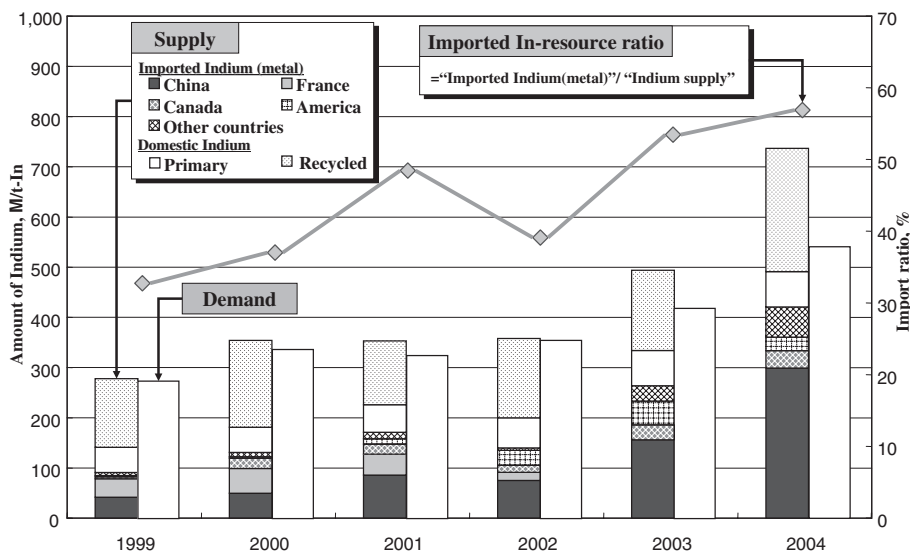

Fig. 2 Supply and demand balance of indium in Japan.

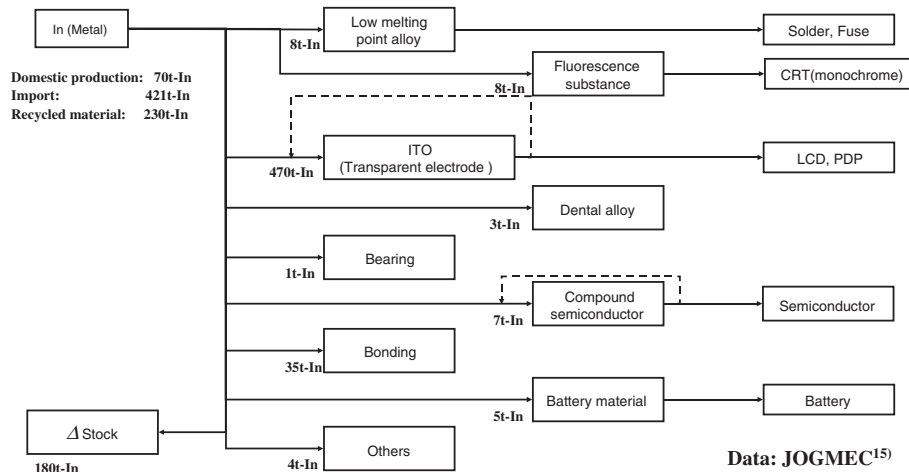

Fig. 3 Indium flow chart in Japan by JOGMEC (2004).

Table 1 Remarks for estimation of indium flow chart

		Remarks
[1]	Indium in target material	Ref. 14)
[2]	Recycled material	Ref. 14)
[3]	Reminder material	"[1] Indium in target material" × 70%/100
[4]	Loss in sputtering process	"[1] Indium in target material" × 20%/100
[5]	Loss in etching process	"[1] Indium in target material" × 5%/100
[6]	Loss in assembling process	"[1] Indium in target material" × 2%/100
[7]	Display panel	"[1] Indium in target material" × 3%/100
[8]	Loss in recycling process	"[3] Reminder material" – "[2] Recycled material"

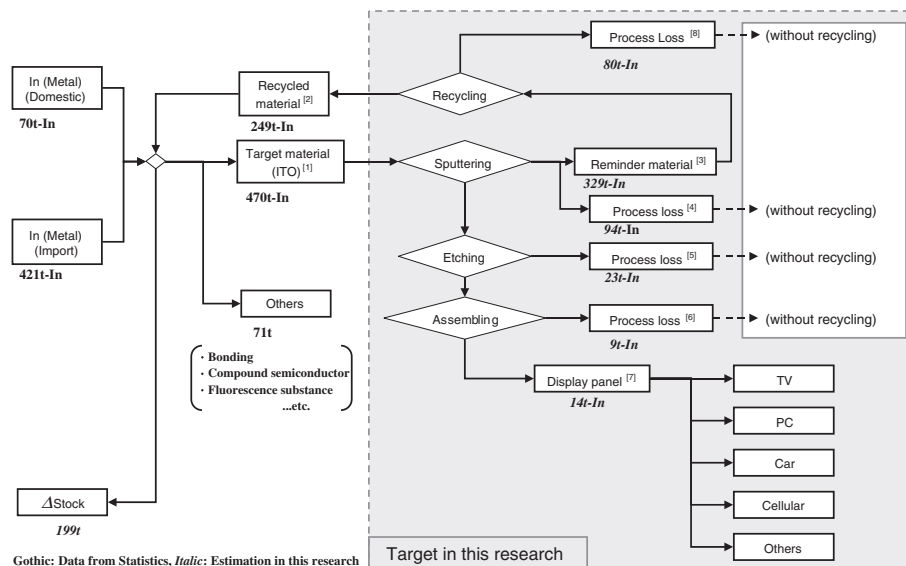

Fig. 4 Estimated Indium flow chart in Japan (2004).

indium contained in FPD products was estimated to be only 14(±2) t-In. This indicates that most of the indium used in the ITO film production process is discarded as process waste.

The estimated value in this study includes error in least significant digit as a result of above, which is based on significant figures shown in JIS K0211. Only median is shown in follows.

3.2 Estimation of Dissipated Indium

At the moment, most of the rare metals contained in post-consumer products are not recovered, which are dissipated or diluted in waste management and recycling system.¹⁸⁾ Typical examples are molybdenum¹⁹⁾ and niobium that are used as alloying element for steel. In this study, the amount of dissipated indium resulting from unrecovered indium scrap

Table 2 Estimated amount of scattered indium

(a) Amount of scattered indium		
Disipated indium		
indium scrap from sputtering	94	t-In
indium scrap from etching	23	t-In
indium scrap from assembling	9	t-In
indium scrap from recycling	80	t-In
Potentially disipated indium		
indium in FPDs	14	t-In
Total	220	t-In
(b) Environmental impacts of indium-scatter		
Environmental impacts of scatter		
Energy consumption	11.4	TJ/t-In
CO ₂ emission	0.5	10 ³ t/t-In
TMR	1.0	10 ⁶ t/t-In

was estimated, and some aspects of the environmental loss of resource scattering were assessed.

The estimated result shows that out of the total quantity of indium scrap generated in the fabrication process, 206 t-In (sputtering waste: 94 t-In, etching waste: 23 t-In, assembly waste: 9 t-In, recycling waste: 80 t-In) is not beneficially used. At the moment, only a part of the indium contained in post-consumer FPDs is recycled. As a result, in 2004, out of 470 t-In used in ITO for transparent electrodes, 220 t-In was dissipated or potentially dissipated.

Some aspects of environmental loss due to resource dissipated was assessed. An assessment of energy consumption, CO₂ emissions, and total materials requirement (TMR) was carried out.^{20,21} TMR is an indicator that combines the material requirements (direct and indirect ones) associated with economic activities and hidden flows. The former is referred to as economic flow; this quantity is available from economic statistics. The latter refers to the amount of materials that is moved in connection with economic and other activities and includes sand generated in mining operations. The energy consumption (51.5 GJ/t-In) and CO₂ emissions (2.3 t-CO₂/t-In) from the production of 1 t-In were quoted from a report by the National Institute for Materials Science (NIMS),²⁰ and the TMR (4.5 × 10³ t-TMR/t-In) was quoted from a paper by Halada.²¹

Table 2 demonstrates the amount of dissipated indium associated with FPDs and the environmental loss by the dissipating of indium. The analysis shows that 221.0 t-In of dissipated indium is equivalent to 11.4 TJ of energy consumption, 0.5 × 10³ t-CO₂ of CO₂ emissions, and 1.0 × 10⁶ t-TMR of TMR.

4. Discussion

Amount of indium in FPDs were estimated based on above-mentioned top-down approach. In order to check the estimated data and to discuss the amount of indium in each FPD, we approximated that based on by bottom-up approach.

First, the amount of indium in mobile phone displays was approximated. Mobile phones contain materials that are useful as resources, such as Ag, Au, Cu and also In. About 50 million t of mobile phone has been produced year by year,

though the recovery system of mobile phone has not established, whose recovery ratio is approximately 31%.¹⁸⁾ From the back ground, recycling systems of mobile phone have been paid attention. Second, the amount of indium in FPDs used in electronic devices such as TVs, PCs, and car navigation systems was then estimated based on the results of the estimation for mobile phones.

4.1 Approximately estimation of indium in display panels of mobile phones

ITO films are used as transparent electrodes in LCD panels, and typical size of a panel in mobile phone is 1.3 ~ 2.9 inch.²²⁾ In this study, we used mobile phone made in 2005 as a sample for analysis, whose size of the panel is 2.5 inch. The electrodes of an LCD panel consist of two layers of thin ITO film. The cross-section of the two layers of an ITO film used as opposing electrodes in an LCD panel (60.6 × 40.8 mm) was analyzed with an electron microscope to measure the film thickness. As a result of the analysis, the thickness of the ITO film layers was observed to be 150 and 265 nm with a total thickness of 415 nm. The amount of indium in the LCD panel was estimated based on this data using the following equation.

$$M_{ITO}^{In} = V_{ITO} \times \alpha_1 \times \alpha_2$$

where M_{ITO}^{In} denotes the amount of indium in the ITO film per mobile phone; V_{ITO} , the volume of the ITO film per mobile phone; α_1 (= 6.46 g/cm³), the weight of In₂O₃ per unit volume of the ITO film; and α_2 , the percentage of indium in In₂O₃. The composition of the ITO film was assumed to be 90 mass% In₂O₃ and 10 mass% SnO₂ based on interview data.

As a result, the amount of indium per mobile phone was estimated to be 5.5 × 10⁻³ g-In. Moreover, we the amounts of indium in 1.3 inch panel (lower value) and 2.9 inch panel (upper value) were estimated based on above mentioned estimation method. In the estimation, the thickness of the ITO film was assumed to be 415 nm. As a result, the amounts of indium in 1.3 inch panel and 2.9 inch panel were estimated 1.2 × 10⁻³ g-In and 6.9 × 10⁻³ g-In, respectively.

According to Machinery Statistics²³⁾ of the Ministry of Economy, Trade and Industry (METI) in Japan, 50,522 × 10³ mobile phone sets were produced in 2004, including personal handy phone system (PHS) phones. Based on the above-mentioned estimations, the amount of indium in ITO films used in mobile phones (including PHS phones) produced in 2004 was estimated to be 0.3 t-In (lower value: 0.1 t-In, upper value: 0.4 t-In).

4.2 Approximately estimation of indium in other FPDs

The amount of indium contained in FPDs used in (1) TVs (LCDs and PDPs), (2) PCs, and (3) car navigation systems was estimated using the amount of indium in the ITO film obtained from the above analysis. In the estimation, the number of electronics devices produced was quoted from METI's statistics.²²⁾ The size of display panel were assumed as follows; 15 ~ 60 inch in TV panel,²⁴⁾ 10 ~ 25 inch in LCD monitor for PC,²⁴⁾ and 4 ~ 10 inch in LCD monitors for car navigation systems. As targets in this study, FPD sizes of 32, 20, 15 and 8 inches were assumed for TV panels, LCD

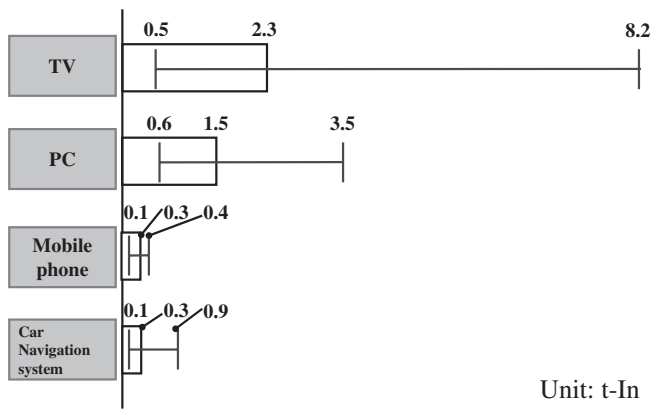

Fig. 5 Estimated result of indium in FPDs (2004).

monitors for desktop PCs, LCD monitors for notebook-size PCs, and LCD monitors for car navigation systems, respectively. An ITO film thickness of 415 nm was assumed to be constant for each FPD, similar to the film thickness for a mobile phone.

In 2004, 3.0×10^6 TV (LCD and PDP) panels were produced. Since the volume of indium in a 32-inch FPD panel is approximately 0.1 cm^3 , the weight of indium in the panel is 0.8 g-In (lower value: 0.2 g-In, upper value: 2.7 g-In) per panel. Therefore, 2.3 t-In (lower value: 0.5 g-In, upper value: 8.2 g-In) is contained in all the TV panels. Similarly, the amount of indium contained in FPDs for PCs and in FPDs for car navigation systems was estimated. Figure 5 shows the estimated result of Indium in FPDs. Approximately 4.3 t-In (lower value: 1.2 t-In, upper value: 12.4 t-In) is used in those FPDs. From the results, it seems that 10 t-In (lower value: 2 t-In, upper value: 13 t-In) is used for other applications such as FPD panels for pachinko game machines, digital video, digital camera, etc. More accurate data can be obtained by carefully examining information on the FPD size for each product type and the amount of indium contained in the FPD. The estimated value by bottom-up approach is nearly to the value estimated by top-down approach.

5. Conclusions

This study investigated the material flow of indium used in ITO for transparent electrodes in 2004, which accounts for 86.9% of the total demand for indium.

The major conclusions are:

- In Japan, 470 t-In is used in ITO for transparent electrodes, out of which 220 t-In is dissipated or potentially dissipated. Furthermore, 220 t-In of dissipated indium is equivalent to 11.4 TJ of energy consumption, $0.5 \times 10^3 \text{ t-CO}_2$ of CO_2 emissions, and $1.0 \times 10^6 \text{ t-TMR}$ of TMR.
- FPDs contain 14 t-In, which is 3% of indium used in ITO for transparent electrodes. The breakdown estimated by bottom-up approach is as follows: TV (2.3 t-

In), PC (1.5 t-In), mobile phone (0.3 t-In), and car-navigation system (0.3 t-In).

Acknowledgments

This work has been supported by Research Institute of Science and Technology for Society (RISTEX) of Japan Science and Technology Agency (JST), and waste management research grant by Ministry of Environment of Japan. We would like to thank Dr. Chisato Yoshida (Tokai University).

REFERENCES

- 1) Japan Oil, Gas and Metals National Corporation: *Stockpiling*, (<http://www.jogmec.go.jp/english/stockpiling.html>), (2006/12/12).
- 2) Ministry of Economy, Trade and Industry: *Yearbook of Iron and Steel, Non-Ferrous Metals, and Fabricated Metals Statistics*, (2005).
- 3) Japan Oil, Gas and Metals National Corporation: *Material Flow of Mineral Resource*, (in Japanese), (2005).
- 4) Rare Metal Association: *Rare Metals Shikihou*, (in Japanese), (2005).
- 5) M. Shimada, K. Ijima, Y. Sawatani, K. Nakajima, T. Nagasaka, T. Tsukihashi, Y. Moriguchi and K. Halada: *Proceedings of 7th International Conference on Ecomaterials*, (2005), pp. 620–633.
- 6) P. H. Brunner and H. Rechberger: *Handbook of Material Flow Analysis*, (The CRC Press, Boca Raton, 2003), pp. 1–159.
- 7) M. Bertram, T. E. Graedel, H. Rechberger and S. Spataro: *Ecological Economics* **42** (2002) 43–57.
- 8) H. Rechberger and T. E. Graedel: *Ecological Economics* **42** (2002) 59–72.
- 9) S. Bringezu, H. Schutz, S. Steger and J. Baudisch: *Ecological Economics* **51** (2004) 97–124.
- 10) A. M. Alfantazi and R. R. Moskalyk: *Mineral Engineering* **16** (2003) 687–694.
- 11) Rare Metal Association: *A List of Base Data for Selecting Seven Metals for National Reserves*, (<http://www.tokubikyo.or.jp/pdf/ichiran.pdf>), (2006/12/12).
- 12) U.S. Geological Survey: *Indium*, (<http://minerals.usgs.gov/minerals/pubs/commodity/indium/indiummcs06.pdf>), (2006/12/12).
- 13) New Energy and Industrial Technology Development Organization: *An Advanced Study on Developing a Global Model for Recycling and Accumulating Waste Resources*, (2005) 64.
- 14) Arumu Publishing: “Industrial Rare Metals 121 (in Japanese)”, (2005), 108–109.
- 15) Japan Oil, Gas and Metals National Corporation: “Rare Metal Stockpiling Data Book (in Japanese)”, (2006), 24.
- 16) Japan Oil, Gas and Metals National Corporation: “Material Flow of Mineral Resource 2005 (in Japanese)”, (2005), 145–148.
- 17) H. Nishida, *Monthly Display* **2** (2002) 36–46.
- 18) K. Nakajima, K. Yamamoto, K. Nakano, K. Kuroda, K. Halada and T. Nagasaka: *Journal of Life Cycle Assessment, Japan*, **2** (2006), 341–346.
- 19) K. Nakajima, K. Yokoyama, Y. Matsuno and Y. Nagasaka: *ISIJ Journal* **47** (2007) 510–515.
- 20) National Institute for Materials Science: “Estimation of CO_2 Emission and Energy Consumption in Extraction of Metals”, *NIMS-EMC Material Data for the Environment* **1** (2004) 84–87.
- 21) K. Halada, K. Ijima, N. Katagiri and T. Okura: *J. Japan Inst. Metals* **650** (2001) 564–57.
- 22) Japan Patent Office, (<http://www.jpo.go.jp/shiryousonota/hyoujun-gijutsu/keitai/9-5-1.pdf#page=1>) (2007/2/21).
- 23) Ministry of Economy, Trade and Industry: “Machinery Statistics”, (<http://www.meti.go.jp/statistics/data/h2d3216j.html>) (2006/12/12).
- 24) K. Betsui: *Fujitsu* **52** (2001) 361–367.