

Irregular AC Losses With Long Time Constants in Large Cable-in-Conduit Conductors

T. Hamajima, Y. Kakusho, K. Hoashi, M. Tsuda, N. Harada, H. Yamada, K. Takahata, and T. Satow

Abstract—A large superconducting coil wound with Cable-in-Conduit (CIC) conductor causes both irregular AC losses that cannot be estimated from short conductor sample test results, and regular AC losses that are proportional to cable twisting pitch squared. We proposed a mechanism forming loops that generated the irregular losses. The CIC conductor is composed of several stages of sub-cables. If one strand on the surface of a sub-cable contacts another strand on the surface of the adjacent sub-cable, the two strands must encounter each other again at the LCM (Least Common Multiplier) distance of all staged cable pitches, and thereby a long loop is formed. We orderly labeled all strands in CIC conductors for the SMES and the LHD. It was found that strands in a triplet were widely displaced from their original positions on one cross section, but contacted each other tightly on the other cross section. This fact suggests that the loop with the large displaced strand links irregularly with external field so that the loops cause the irregular AC losses. Moreover, it indicates that a contacting length of the large displaced strands can be quite long, giving rise to a low contact resistance for the loop, and leading to the long time constants. It is believed that the widely displaced strand are inherent in a CIC conductor. It was demonstrated that the strand surface coated with CuNi was effective to suppress the irregular AC losses.

Index Terms—CIC conductor, contacting resistance, irregular AC loss, strand location, time constant.

I. INTRODUCTION

RECENT experiments on AC losses in a large superconducting coil wound with Cable-in-Conduit (CIC) conductor have shown that coupling AC losses are composed of irregular coupling losses that cannot be estimated from short-sample test results, as well as regular coupling losses that are proportional to largest cable twist pitch squared [1]–[8]. The irregular AC losses with long time constants were typically observed in a Japanese SMES model coil, which was tested at Japan Atomic Energy Research Institute (JAERI) and Lawrence Livermore National Laboratory (LLNL) [1]–[5]. Similar AC losses with long time constants were appeared in a poloidal superconducting coil of the Large Helical Device (LHD) in National Institute for Fusion Science in Japan [6]–[8].

Current loops, which were irregularly formed in the cable, decay with a long time constant and hence enhance the AC loss.

Manuscript received August 5, 2002. This work was supported in part by the Japan society for the Promotion of Science and the NIFS Collaborative Research Program.

T. Hamajima, Y. Kakusho, K. Hoashi, M. Tsuda, N. Harada, and H. Yamada are with the Department of Electrical and Electronic Engineering, Yamaguchi University, Ube, Yamaguchi 755-8611, Japan (e-mail: hamajima@yamaguchi-u.ac.jp).

K. Takahata and T. Satow are with National Institute for Fusion Science, Toki, Gifu 509-5292, Japan.

Digital Object Identifier 10.1109/TASC.2003.813082

In addition, the loops may induce an imbalanced current distribution in a conductor, potentially causing so called RRL (ramp rate limitation), which was observed in DPC coil experiments [9]–[14]. In US-DPC coil experiments, the loops linked with external field generated the RRL, and their loop areas were estimated from quench data [9].

The loops that cause irregular AC losses have characteristics of various long time constants and large number. We propose a new mechanism whereby long loops are formed to satisfy the above characteristics [4]. The CIC conductor is composed of several sub-cable stages. If one strand on the surface of a sub-cable contacts another strand on the surface of the adjacent sub-cable, the two strands will encounter each other again at the LCM (Least Common Multiplier) distance of all stages of cable pitches, thereby resulting in formation of a long loop.

In this paper, the irregular AC losses with the long time constants are discussed in the context of two coil designs, the Japanese SMES model coil and the LHD-IV (Inner Vertical) coil. We have measured cross-over contact resistance of two strands for these two coils. Loop time constants are calculated and then compared with the observed ones. We identified and labeled all strand in the real CIC conductors for the SMES and the LHD-IV, disassembling carefully the cable after peeling the conduit, in order to investigate all strand locations and local configurations. We explain the long time constant and the irregular AC losses. We finally discuss methods to suppress the irregular AC losses.

Main parameters of the SMES model coil and LHD-IV coil are listed in Table I.

II. IRREGULAR COUPLING AC LOSSES

The AC losses in the SMES model coil were measured for various rise times and peak currents [1]–[3]. Their normalized AC losses are shown in Fig. 1 as a function of inverse rise time. Almost all the measured data were plotted on a particular line, and thereby the coupling losses are described in terms of time constants: a short time constant of about 0.22 s and a long time constant of about 30 s. The short time constant is in good agreement with that measured from short-sample AC-loss tests obeying ordinary coupling-loss relations, such as being proportion to twist pitch squared. The long time constant cannot be observed in the short-sample test results and must be measured in a coil.

In the SMES model-coil tests, the existence of loops in the coil with various long time constants was confirmed by signals of Hall probes mounted on the coil so as to avoid the main field. The signals revealed long time constants in the range of about 4 s to 110 s occurred in the coil [2]–[4]. It was also confirmed

TABLE I
MAIN PARAMETERS OF SMES AND LHD-IV COILS

	SMES	LHD-IV
<i>Coil</i>		
I.D. × O.D. × H.	2.76 m × 3.24 m × 0.234 m	1.6 m × 2.1 m × 0.47 m
Turns	11 × 8 = 88	15 × 16 = 240
Inductance	39.6 mH	314 mH
Operation current	20 kA	20.8 kA
Maximum field	2.84 T @ 20 kA	5.2 T @ 20.8 kA
<i>Conductor</i>		
Conduit outer dimension	25.4 mm × 27.8 mm	23.6 mm × 27.6 mm
Thickness	2.3 mm	3.0 mm
Void fraction	36 %	38 %
Strand material	NbTi/Cu/CuNi	NbTi/Cu
Strand diameter	0.62 mm	0.767 mm
Configuration	3 × 3 × 3 × 3 × 3 × 4 = 972	3 × 3 × 3 × 3 × 6 = 486
Twist pitches [mm]	60 / 120 / 180 / 240 / 300 / 360	60 / 100 / 150 / 220 / 400

from flux-loop decay signals of voltage taps soldered on the conductor that the loop time constant was of the order of 130 s [3]. Clearly, there existed loops with long time constants, and we estimated the averaged to be about 30 s. If current rise time is the same order as the averaged long time constant, the irregular losses may become larger than the regular coupling losses.

The AC losses of the LHD-IV coil were also measured and the normalized coupling loss results suggest the presence of the irregular losses with an average long time constant of about 120 s, as well as the regular losses [6]–[8].

According to the mechanism proposed previously [4], the pair of strands on the semi-final stage of the cable can make the largest loop. We can treat the largest loop as a long parallel conductor and calculate its inductance L as follows:

$$L = \frac{\mu_0 \cdot l_t}{\pi} \ln \frac{d-a}{a} \text{ [H]} \quad (1)$$

where, l_t is the loop length, a is radius of filament region, μ_0 permeability in free space, d averaged distance between strands in the loop.

The loop inductances of the LCM length for the SMES and LHD-IV are about 5 μH and 15 μH , respectively. Since the width of a loop has limited range, the fundamental time constant ($\tau = L/R$) depends mainly on the contact resistance R .

III. CONTACTING RESISTANCES OF THE LOOPS

We measured the cross-over point contact resistance of pairs of strands in the SMES and LHD-IV conductors. The typical measured $V-I$ curve of the strands with oxidized surface used for the SMES had irreversible hysteresis characteristics with a tendency to reduce the contacting resistance after the contact was exposed to larger currents [5]. In this case, we finally obtained 50 $\mu\Omega$ for the cross over resistance (Table II). The $V-I$ curves for the strands of the LHD-IV conductor had a linear characteristics and the cross-over resistance is about 50 $\mu\Omega$.

These resistances are not so small corresponding to time constants for the SMES and LHD-IV conductors of less than $\tau = 0.1$ and 0.3 s, respectively. Because the cross over contact is a point less than 0.1 mm in length, this observation lead us to in-

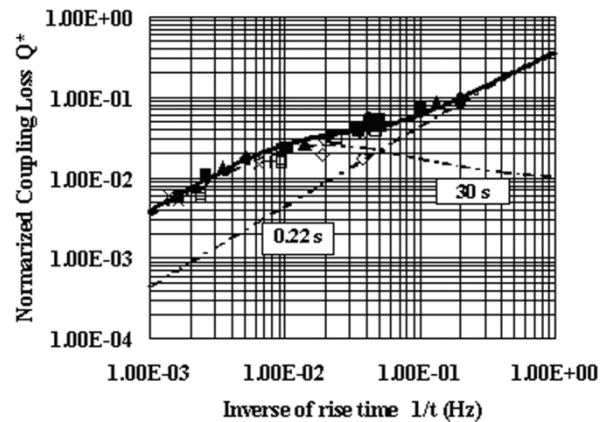

Fig. 1. Normalized coupling loss as a function of inverse charging time. The loss consists of two major components with different time constants; $Q^* = Q_1 + Q_2 \times 0.06$. The time constant of Q_1 is about 0.22 s, and that of Q_2 about 30 s.

TABLE II
CROSS-OVER CONTACT RESISTANCES BETWEEN THE STRANDS FOR SMES AND LHD-IV CONDUCTORS

	SMES reduced CICC	LHD-IV
Number of the triples with large displaced strand	8	35
Rate of the displaced triplets	10 %	22 %
Rate of the triplets on the boundaries	7 %	10 %

vestigate other contact configurations of the two strands forming the loops.

On the other hand, we have also measured the cross-over contact resistance of CuNi coated strands used for the improved SMES coil (Table II), where the irregular AC losses were not observed [2], [3]. The resistance was about 1 m Ω that is about 20 times as large as those of strands in the SMES and LHD-IV conductor.

IV. STRAND LOCATIONS IN CICC

We identified and labeled all strands in a real CICC conductor to investigate all strand locations on a cross section of the cable and their configurations. The processes of disassembling the conductor and labeling the strands are shown in Fig. 2, according to inverse process of cable fabrication. First, a sample of about 1 m in length was provided and diagonal corners of conduit were machined. Second, we clamped about 5 cm in length from the both ends to fix the strand locations as they are, and peeled off the remaining conduit. Third, since the center of the cable was easily disassembled according to each sub-cable stage, we labeled semi-final staged sub-cables at first, and then proceeded the same way to label all strands in an orderly fashion, as shown in Fig. 3.

The fully identified and labeled strands for the LHD-IV coil are shown in Fig. 4, where lines are boundaries of sub-cables. The detailed observations reveal that strands in some triplets are widely displaced from the original positions, whereas they contacted each other tightly in another location. This means that a strand from another group can be inserted between strands in

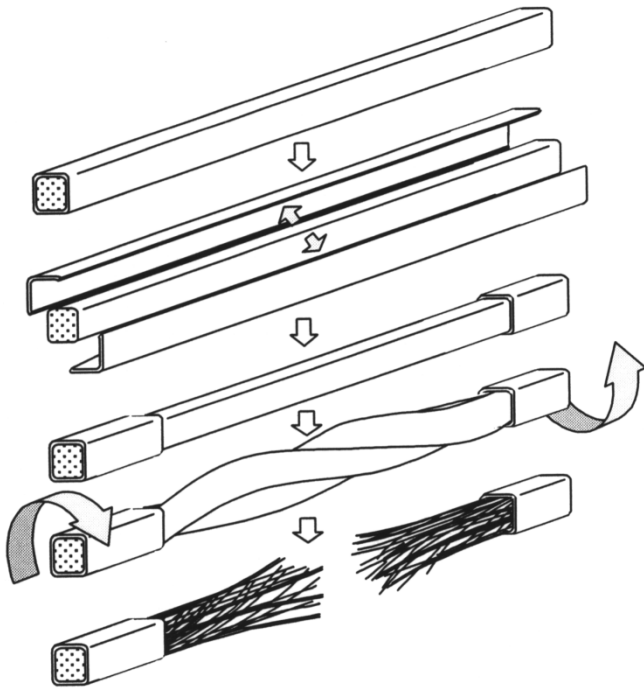

Fig. 2. Disassembling the cables from CICC and orderly labeling all strand locations according to inverse process of fabrication.

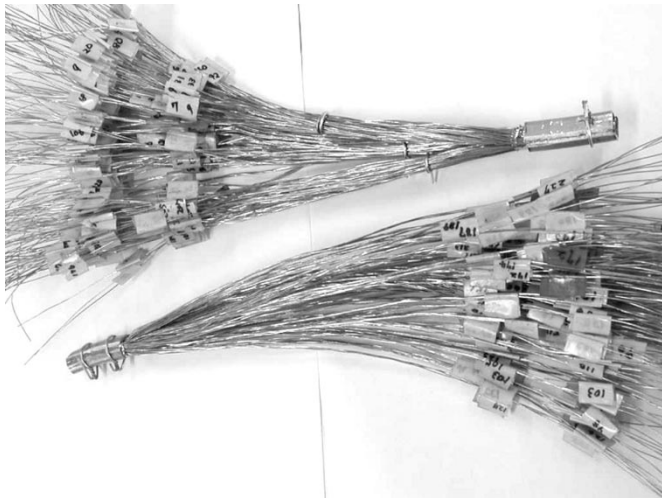

Fig. 3. Orderly labeled strands at the center of the cable and determination of all strand locations on the both end cross sections.

the displaced group over an appropriate distance, and hence the contact length can become longer.

We counted up triplets with a strand displacement large enough that another strand could be inserted into the triplet and listed in Table III. It was found that the rates of the displaced triplets are about 10% for the SMES, and 20% for the LHD-IV coil, which suggests that there are a large number of loops with long line contacts and triplets with widely displaced strands like triplet (58,59,60) in Fig. 4 can have the largest irregular flux.

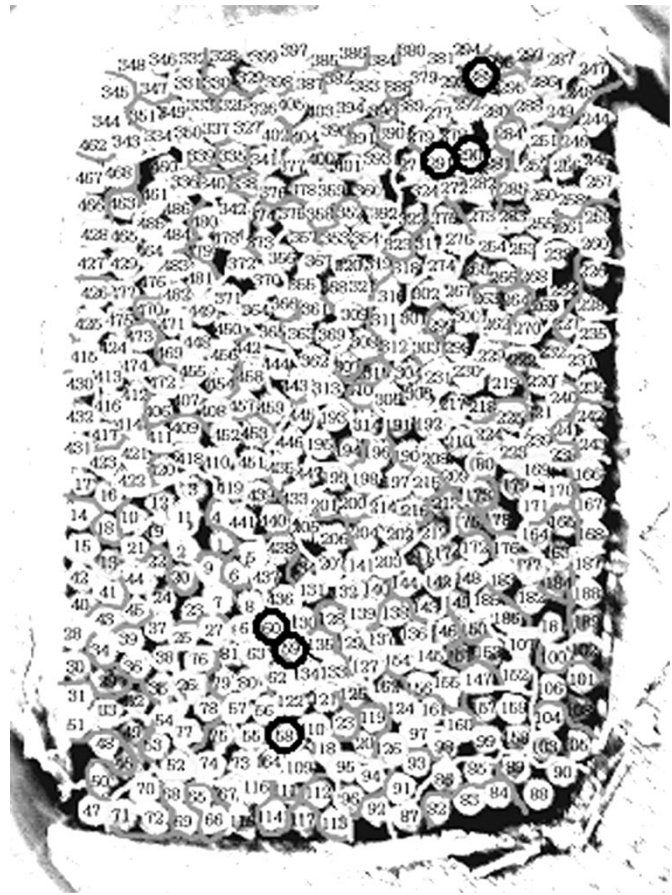

Fig. 4. Labeled numbers are well ordered corresponding to fabrication. Some first sub-cables with widely displaced strands are indicated with black circles.

TABLE III
NUMBER OF TRIPLETS WITH LARGE DISPLACED STRAND FOR SMES
REDUCED CICC (243 STRANDS) AND LHD-IV

	SMES reduced CICC	LHD-IV
Number of the triples with large displaced strand	8	35
Rate of the displaced triplets	10 %	22 %
Rate of the triplets on the boundaries	7 %	10 %

V. DISCUSSION

It is believed from these observations of two typical CIC conductors that the triplet with widely displaced strands are inherent in a CIC conductor and occupy 10–20% of all triplets in the conductor.

Two important conclusions can be made from these observations; (a) the LCM loops with widely displaced strands have irregular loop area that can not be canceled out, (b) the widely displaced strand can give long line contact with another strand inserted into the triplet.

The former conclusion suggests that the irregular loops have enhanced coupling to external fields, and thereby increasing the irregular coupling losses. The irregular losses depend on the loop time constants that closely relate the contact resistances.

The latter conclusion allows us to consider how contact resistances affect the loop time constants as well as the irregular losses. Since the measured point contact resistances between two strands for both coils are about $50 \mu\Omega$, fundamental time constants are merely about 0.1 and 0.3 s for the SMES and the LHD-IV, respectively. The corresponding contact length must be less than 0.1 mm, whereas some large displaced strands could have more than 10 mm line contacts with the inserted strands. These observations allow us to explain well both the long time constants from 4 to more than 130 s, and the irregular losses in the experiments.

In order to suppress the irregular AC losses, we have fabricated the strands with CuNi surface of $40 \mu\text{m}$ in thickness and carried out the small coil tests [2], [3]. The irregular AC losses were not observed in the coil. This stems from that the cross-over contact resistance was so large that time constants could become shorter and amount of irregularly coupled loss could become smaller. The coil stability tests showed that the coil had enough stability performance [2]. Therefore, the CuNi layer on the strand can play an important role to suppress the losses, even if the CICC has widely displaced strands coupling to the external fields.

VI. CONCLUSION

We have investigated the formation of long loops with the LCM length of all the sub-cable twist pitches in order to understand the mechanism causing the irregular losses in the SMES and the LHD-IV coils. The LCM lengths for the both conductors are 3.6 m and 13.2 m, and their inductances are about $5 \mu\text{H}$ and $15 \mu\text{H}$, respectively. The measured cross-over contact resistances are about $50 \mu\Omega$, which is too large to explain the long time constants. We labeled all strand locations in the conductors, and it is found that about 10-20% of all the triplets have the widely displaced strands, which can have long line-contact lengths compared with a cross-over point, and also forms an irregular loop that couples to external field. This fact allows us to explain the long time constants from 4 s to 130 s, as well as the enhanced irregular AC losses for the SMES and the LHD-IV.

We have also measured the cross-over contact resistance of the strands coated with CuNi. Since it was about $1 \text{m}\Omega$, and reduced the time constant, the CuNi coating is effective to suppress the losses.

REFERENCES

- [1] T. Hamajima, M. Shimada, M. Ono, H. Takigami, S. Hanai, Y. Wachi, Y. Takahashi, K. Matusi, T. Ito, T. Isono, H. Tsuji, K. Shinoda, T. Mine-mura, T. Himeno, I. Takano, and T. Satow, "Test results of the SMES model coil-pulse performance," *Cryogenics*, vol. 39, pp. 351–357, 1999.
- [2] T. Hamajima, S. Hanai, Y. Wachi, M. Kyoto, M. Shimada, M. Ono, K. Shimada, L. Kushida, M. Tezuka, N. Martovetsky, J. Zbasnik, J. Moller, N. Hirano, K. Shinoda, M. Yamamoto, I. Takano, T. Himeno, and T. Satow, "Test results of the 100 kWh SMES model coil—AC loss performance," *Cryogenics*, vol. 39, pp. 947–953, 1999.
- [3] T. Hamajima, S. Hanai, Y. Wachi, M. Kyoto, M. Shimada, M. Ono, K. Shimada, L. Kushida, M. Tezuka, N. Martovetsky, J. Zbasnik, J. Moller, Y. Takahashi, K. Matsui, T. Isono, N. Hirano, K. Shinoda, M. Yamamoto, I. Takano, T. Himeno, and T. Satow, "AC loss performance of the 100 kWh SMES model coil," *IEEE Trans. Applied Supercond.*, vol. 10, p. 812, 2000.
- [4] T. Hamajima, M. Yoshida, H. Shimamura, N. Harada, M. Tsuda, S. Hanai, and T. Satow, "A mechanism causing an additional AC loss in a large CICC coil," *IEEE Trans. Applied Supercond.*, vol. 10, p. 1860, 2001.
- [5] T. Hamajima, N. Harada, T. Satow, H. Shimamura, K. Takahata, and M. Tsuda, "Long time constants of irregular AC losses in a large superconducting coil," *IEEE Trans. Applied Supercond.*, to be published.
- [6] T. Mito, K. Takahata, A. Iwamoto, R. Maekawa, N. Yanagi, and T. Satow, "Extra AC loss for a CICC coil due to the nonuniform current distribution in the cable," *Cryogenics*, vol. 38, pp. 551–558, 1998.
- [7] T. Mito, K. Takahata, A. Iwamoto, R. Maekawa, N. Yanagi, T. Satow, F. Smiyoshi, and S. Kawabata, "AC loss measurements of the experiments on a single inner vertical coil (EXIV) for the large helical device," *IEEE Trans. Applied Supercond.*, vol. 7, p. 330, 1997.
- [8] K. Takahata *et al.*, "Excitation test results on a single inner vertical coil for the large helical device," *IEEE Trans. Applied Supercond.*, vol. 7, p. 477, 1997.
- [9] M. Takayasu, V. Vysotsky, S. Jeong, P. C. Michael, J. H. Schultz, and J. V. Minervini, "Spike voltages seen during "quick charge" ramp limitation tests on Nb_3Sn cable-in-conduit conductors," *IEEE Trans. Applied Supercond.*, vol. 7, p. 150, 1997.
- [10] S. Jeong, J. H. Schultz, M. Takayasu, V. Vysotsky, P. C. Michael, W. Warnes, and S. Shen, "Voltage spike observation in superconducting cable-in-conduit conductor under ramped magnetic fields: 1. Experiment," *Cryogenics*, vol. 37, p. 299, 1997.
- [11] V. S. Vysotsky, M. Takayasu, S. Jeong, P. C. Michael, and V. V. Vysotskaia, "Voltage spikes in superconducting cable-in-conduit conductor under ramped magnetic fields. Part 2: Analysis of loop inductances and current variations associated with the spikes," *Cryogenics*, vol. 38, p. 387, 1998.
- [12] N. Koizumi, K. Okuno, Y. Takahashi, H. Tsuji, and S. Shimamoto, "Current imbalance due to induced circulation currents in a large cable-in-conduit superconductor," *Cryogenics*, vol. 36, p. 409, 1996.
- [13] N. Koizumi, Y. Takahashi, M. Nishi, T. Isono, H. Tsuji, M. Ono, T. Hamajima, and T. Fujioka, "Ramp-rate limitation due to current imbalance in a large cable-in-conduit conductor consisting of chrome-plated strands," *Cryogenics*, vol. 37, p. 441, 1997.
- [14] N. Koizumi, K. Azuma, K. Macfall, K. Matsui, Y. Takahashi, and H. Tsuji, "Quasitwo-dimensional numerical model for stability simulation of a cable-in-conduit conductor," *Cryogenics*, p. 495, 1999.
- [15] S. Hanai *et al.*, "The SMES model coil—Fabrication," *Cryogenic Eng.*, vol. 33, pp. 460–466, 1998.