

CRYSTAL GROWTH OF RARE EARTH COMPOUNDS IN CLOSED SYSTEM

著者	SUZUKI Takashi, OCHIAI Akira, KITAZAWA Hideaki, KWON Y. S., OYAMADA Akira, SHIDA Hiroshi, OZEKI Shinya, NAKAMURA Osamu, TOMONAGA Norihisa, HAGA Yoshinori, OMINO Akira, KASUYA Tadao
journal or publication title	The science reports of the Tohoku University. Ser. 8, Physics and astronomy
volume	11
number	2/3
page range	175-227
year	1991-01-31
URL	http://hdl.handle.net/10097/25724

CRYSTAL GROWTH OF RARE EARTH COMPOUNDS IN CLOSED SYSTEM.

Takashi SUZUKI, Akira OCHIAI, Hideaki KITAZAWA, Y.S. KWON,
Akira OYAMADA, Hiroshi SHIDA, Shinya OZEKI, Osamu NAKAMURA,
Noriyhis TOMONAGA, Yoshinori HAGA, Akira OMINO and
Tadao KASUYA

(Received on January 7, 1991)

Abstract

Remarkable improvements have been made on the crystal growth of rare earth pnictides and chalcogenides by the development of new growth technique and the construction of several new equipments for the crystal growth such as electron beam welding system of tungsten crucible provided with large glove box and vacuum HF furnace. This system has really worked on obtaining excellent quality of single crystals and made easier to explore unknown materials of rare earth compounds. Interesting and attractive physical properties of these compounds were obtained from the crystals produced by this system and contributed to extend a new scope of the heavy Fermion physics.

Key words: (Electron Beam Welding) (W crucible) (Single Crystal)
(Rare Earth compound) (HF furnace) (Heavy Fermion Physics)
(Glove Box)

Contents

1. Introduction
2. Flow Chart of the Sample Preparation
3. Pre-reaction of the Sample
4. Processing the Refractory Metal Crucible
5. Performance of Glove Box for Multi - Purpose
6. Furnace
 - 6.1 Vacuum Furnace
 - 6.2 Vacuum Furnace heated by High Frequency (HF) Induction
 - 6.3 Hot Isostatic Pressing (HIP) Furnace
 - 6.4 Three Zone Furnace for Chemical Transport Method
7. Electron Beam Welding System
8. Crystal Growth of Rare Earth Compounds and Their Physical Properties
 - 8.1 The 1:1 Compound of Rare Earth Pnictides and Chalcogenides
 - 8.2 The Crystalization of the Incongruent Materials like Yb_4As_3
 - 8.3 Chemical Vapor Growth Method of U_3X_4
 - 8.4 Bridgman Method of Intermetallic Compound in Closed System
9. Summary

1. Introduction

It had been believed that 4f electron is localized in the solid state of rare earth compounds⁽¹⁾. However it has been recently revealed that the localized state is not always true and sometimes f electron can move in the crystal. Typical examples are valence fluctuation and heavy Fermion state^(2,3). These states indicate interesting and unusual phenomena in their transport, magnetic, optical and thermal properties, and suggest that many body effects of f-electron is fundamentally important to understand these phenomena⁽⁴⁾. For this consequence in the solid state physics, much attention has been attracted on these phenomena and many studies have been extensively carried out in both experiments and theories by many researchers in the world. Intermetallic compounds of rare earth have been explored well for the sake of rather easy and speedy sample preparation by adoption of the arc melting method, and interesting unknown phenomena have been successively discovered, such as heavy Fermion superconductivity in CeCu₂Si₂, UBe₁₃ and UPt₃, and heavy fermion without any magnetic order in CeCu₆ and CeAl₃ etc. On the other hand, rare earth pnictides and chalcogenides in which a great number of materials including three components system have not been studied so well because of the difficulties of sample preparation.

Anyway to progress these studies successfully, one of the most important works is to get a large and high quality single crystals of rare earth compounds. Neutron scattering experiment for the investigation of magnetic excitation requires a rather large single crystal of the size of cubic cm, and on the other hand de Haas van Alphen (dHvA) effect measurement for the observation of Fermi surfaces requires an absolutely pure but not so large single crystal of the size of cubic mm for the satisfactory detection of the signal. However it is not so easy to get such a single crystal especially in rare earth compounds with pnictogen atoms (N, P, As, Sb, Bi) or chalcogen atoms (S, Se, Te). Because the melting point of the 1:1 compound usually exceeds 2000°C and the vapor pressure at this temperature is also very high. So if we apply the method of crystal growth in open system to these materials, such as Czochralski pulling method heated by arc or zone refining method by electric high frequency power, a sample easily vaporizes and escapes completely even so introducing high pressure of Ar gas, because Ar gas only reduces the rate of evaporation of the sample kinematically. In addition to prevent evaporation, the control of

partial pressure of components is very important to keep the stoichiometry in a crystal. Therefore it is quite important to make crystals of these compounds in closed system. To encapsulate raw materials of these crystals, metals with high melting point are used for the crucible materials, however, only W, Mo and Ta metals are available because of their stability in such ultra high temperature, machinability (but not so easy) and capability of welding in vacuum. The best one in the three metals is tungsten because the reactivity between tungsten and these compounds is smallest.

Up to 1983 in Japan, only our group (Department of Physics, Tohoku University) had been able to get single crystals of these compounds because we had a high frequency furnace up to 3000°C. But there were several weak points from the standpoint of total system of crystal growth.

Fortunately by the financially support of the Ministry of Education in 1984, we could construct a most suitable crystal growth and handling system. This enabled us easily to explore unknown materials, to develop new techniques of crystal growth and to make a great progress in our activities. Now we are one of the rare group which have a superior total system of crystal growth of rare earth compounds especially pnictides and chalcogenides. Here we shall report the performance of the total system of crystal growth constructed by us and newly developed technique for crystal growth in detail such as fundamental procedure of handling etc. We shall also report how to improve the quality of crystals and our activities introducing measured results of several physical properties. These results could give a new scope in heavy Fermion physics.

2. Flow Chart of the Sample Preparation

Sample preparation procedures performed by us are schematically shown in Fig.1. The sample preparation consists of synthesis of chemical compound for crystal growth (pre-reaction), preparation of crucible, encapsulation and crystal growth.

3. Pre-reaction of the Sample

Usually pre-reaction of the constituent elements of the compound is carried out in a vacuum sealed quartz ampoule before encapsulating in a refractory metal crucible to prevent evaporation and escaping of the constituents by heat during electron beam welding in vacuum. Before preparation of ampoules, a quartz tube is thoroughly washed with acetone, HF and de-ionized water successively. During glass blowing and after shaping, the quartz tube is cleaned by heat of flame from one end to another throughout. This cleaning should be done again just before use. Nowadays commercially available quartz tubes are already cleaned up, so this cleaning procedure is practically not necessary except for special case such as crystal growth by vapor transportation in a quartz ampoules.

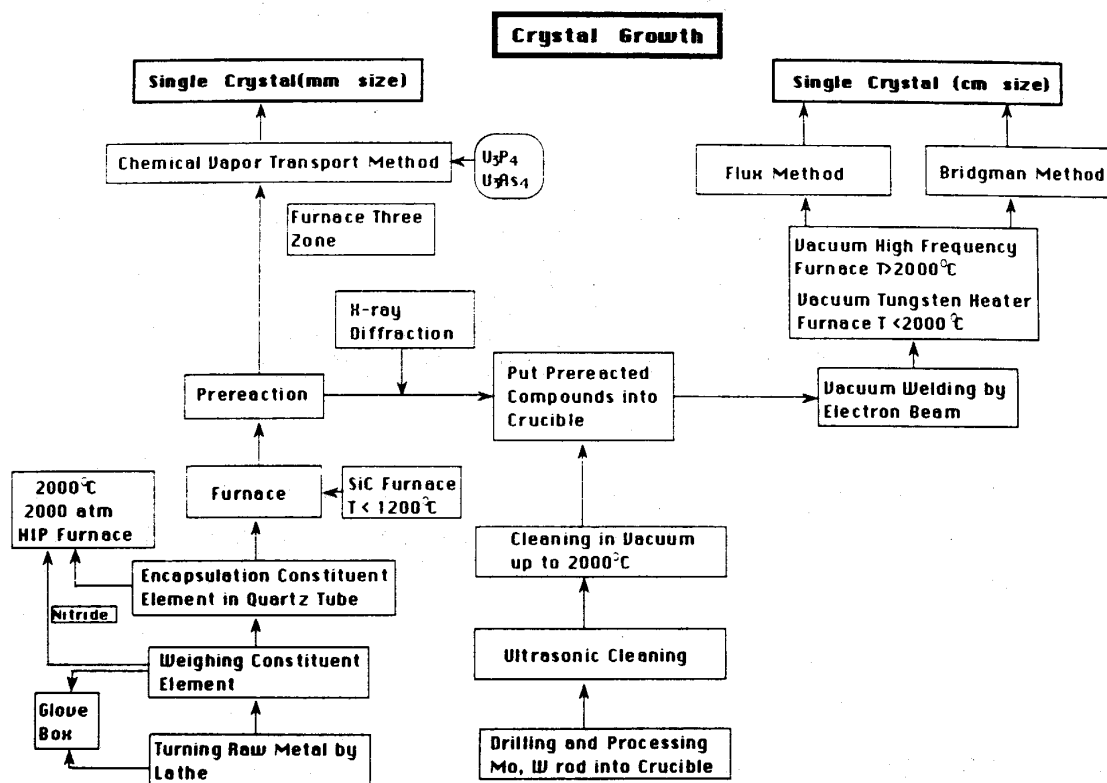

Fig.1 Flow chart of sample preparation

It is desirable to obtain rather rapid reaction rate between elements, so that the bulk rare earth metal should be cut into small pieces by lathe in the glove box described in chapter 5. To control strongly exothermic reaction and to prevent explosion of ampoules, which is of frequent occurrence in the beginning of the reaction, simple and clever design of the ampoule have been developed⁽⁵⁾ as shown in Fig.2. The spatial separation of the elements and gradual and controlled heating in a two-zone furnace allows synthesis of the compounds from a rare earth metal and volatile element very smoothly preventing direct reaction between the constituents and the quartz surface completely. Even in a single zone furnace there is a temperature gradient of itself, so we can control the reaction rate by changing the position of the ampoule in the furnace.

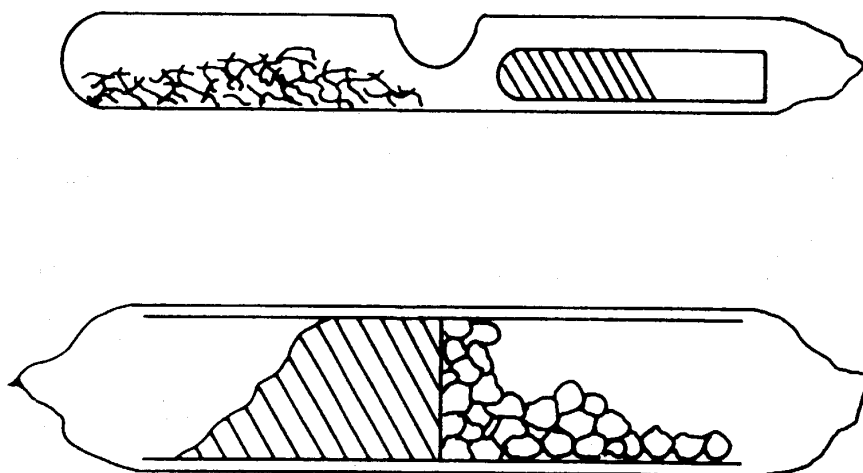

Fig.2 Quartz ampoule designs to prevent strongly exothermic and explosive reactions between a rare earth metal and a volatile component.

After almost pre-reaction is over the content is taken out from the ampoule to grind and mix well. Then it is encapsulated and put again in the furnace. This process is repeated several times to ensure complete reaction. We obtain powder of these compounds by this pre-reaction. It is better to press this powder into a hard bulk by usual press method or the press method in HIP furnace which is newly adopted by us (see chapter 6-3). After pre-reaction co-existence of the other phases of an

objective compound is now not so problem if these phases are not so volatile and does not easily escape during sealing of a refractory metal crucible by electron beam welding, because the other phases can disappear and turn into stoichiometry compound by itself in heating process of crystal growth provided that the objective phase is congruent. If this phase is incongruent, co-existence of the other phases depends on the phase diagram. By the way our new developed method of the crystal growth for incongruent compounds seems possibly to utilize the other phases as some kind of flux (see chapter 8-2). In this case the existence of other phase is definitely important. There must be several ways to perform pre-reaction but one must choose the best way in accordance with chemical properties of the objective material considering vapour pressure, reactivity with quartz, etc. Pre-reaction is usually performed in rather low temperature to prevent explosion of the quartz ampoule caused by vapour pressure of the constituents, and take a long time of several weeks. Non-metallic elements are usually very volatile for example phosphor pressure's in closed tube increases to 100 atm at 400°C. A convenient quick method to apply a HIP furnace is developed by us. This furnace can be operated under maximum gas pressure of 2000 atm. and temperature up to 2000°C. In principle we can carried out the pre-reaction under 2000 atm of the partial pressure of nonmetallic element if we can balance the internal and the external pressure of quartz tube. Fortunately usual quartz tubes bear to external pressure up to 100 atm but easily break by internal pressure of only 10 atm. So it is allowed to operate the HIP furnace even in unbalance pressure of about 100 atm between external and internal pressure, as far as external pressure is larger than internal one. In practice, it is important to shape the end of quartz tube round as much as possible because the stress strongly concentrates on the pointed end of the tube and causes a breaking out of the tube. So generally we cannot use the tube under given maximum stress value. It depends on the technique how to make a round end. There is another limitation in applying external pressure as follows. We cannot directly measure the internal pressure but only can estimate from the table of relation between temperature and partial pressure. Then we choose the operating temperature of the furnace under the given condition mentioned above. However we should take account of exothermic reaction. If this reaction takes place rapidly, the temperature in a tube increases independently by self heating and naturally causes the increasing of the internal pressure. We perform pre-reactions taking account of these

limitations mentioned above. We have succeeded to prepare raw materials for crystal growth such as $CeAs$, Ce_4As_3 , CeP , CeS , Ce_3S_4 , $EuSe$, $LaAs$, La_4As_3 , Sm_4As_3 , SmS , $SmSe$, Sm_3Se_4 , $YbAs$, Yb_4As_3 , YbP , etc. by this method.

4. Processing the refractory metal crucible

Available crucibles are limited in the refractory metal of Mo, Ta and W of which the melting point are $2610^\circ C$, $2996^\circ C$ and $3387^\circ C$ respectively. The Mo rod is cheapest and one-third of the price compared to the others and has a easy processing nature as well as Ta which can be cut and drilled by usual tool. In this sense Mo is rather preferable in using below $2000^\circ C$ which is limited by its thermal stability. Unfortunately the reactivity of Mo with a sample is inferior to that of W even below $2000^\circ C$, so W is best for the crucible and can be used up to $3000^\circ C$. However the processing nature of W is worst and not so easy to make a crucible from a rod. It is very expensive to ask a W crucible for a company, so we determined to make it by ourselves from W rod for only economical reason that is very important point for us.

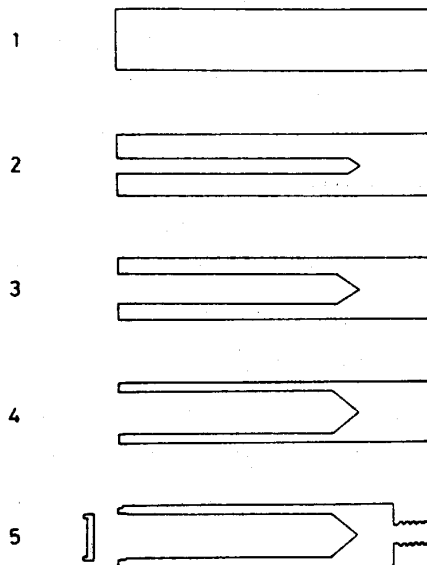

Fig.3 Processing of a tungsten crucible from the rod by drilling

After many efforts of trial and error we could find out that a concrete drill is best for drilling of a W rod. Of course there are some other available and superior drills for W. But these are also very

expensive. We have to grind concrete drills several times in the process of drilling. The detail drilling procedure is shown in Fig.3.

When we want to make the bottom of the hole of the crucible with sharp taper which is important to grow a initial seed crystal in Bridgeman method, we make it by electric discharge machining using Cu rod with fine pointed end. This machining is also useful to make the inside surface of the crucible smooth which is important to prevent the occurrence of the random nucleation of seed. After processing of the crucible, it must be cleaned up. First we wash it with brash in acetone and wash it in acetone by ultrasonic cleaner, then put it into the mixed acid of HF and HNO₃ to solute impure metals and wash with de-ionized water. The most important and final cleaning is performed by heating it up to 2000°C in vacuum, that temperature is a little higher than decomposition temperature of tungsten oxide. In case of Mo this final cleaning is done at 1700°C.

These refractory metal crucible cannot be used for rare earth boride or rare earth alloys for their strong reactivity with the sample. In such a case there are several possibilities. To avoid direct touch between the metal crucible and the sample, insertion of another insulating commercial crucible can work very well, such as pyrolytic BN, pyrolytic carbon, Thoria, Magnetia, Alumina, Zirconia and SiC etc. Of course the choice of these materials depends on what kind of sample to make and the reactivity between the sample and the material which must be checked in each case. For example pyrolytic BN is most preferable for three components system of rare earth boride compounds such as CeRh₃B₂. CeS has also a great possibility for this purpose which had been explored by E.D. Eastman et al⁽⁶⁾ but is not yet commercial. The reactivity of CeS tested by them is shown in Table 1. Recently we have made this crucible by HIP furnace for our use as described later. It is desirable to explore other variations of stable at high temperature and less reactive crucible which may have promising future to search.

CRYSTAL GROWTH OF RARE EARTH COMPOUNDS IN CLOSED SYSTEM

Table 1. Experimental fusions in CeS by E. D. Eastman et al.

	Metal	Temp. (°C)	Time (min.)	Appearance
1	Uranium	1300	5	Shiny surface, no attack
2	Uranium	1475	30	Shiny surface, no attack
3	Uranium	1900	4	Dull golden surface, no attack
4	Cerium	1500	15	Silvery concave surface; no apparent attack
5	Cerium	1500	15	Metal soaked into crucible of 25% porosity
6	Thorium	1825	6	Sound metallic ingot; stuck to crucible
7	Magnesium	900	5	Sound ingot; slight sticking to crucible
8	Beryllium	1400	5	Sound ingot; stuck to crucible
9	Bismuth	1200	5	Sound ingot; slight attack
10	Aluminium	1500	10	Sound ingot with thin black coating
11	Beryllium	1500	10	Sound ingot, no attack
12	Iron	1500	10	Sound ingot; no attack but stuck to crucible
13	Titanium	1500	10	Sound ingot; no attack but stuck to crucible
14	Platinum	1900	10	Crucible badly attacked to give $CePt_2$ and Ce_3S_4
15	Tin	1200	3	Gray film on ingot and crucible where in contact; no other apparent attack
16	Zinc	500	1	No apparent attack; ingot not stuck to crucible; no attack
17	Zinc	700	5	Ingot not stuck to crucible no attack

5. Performance of glove box for multi-purpose.

Many rare earth metals and their compounds are unstable in the air. Therefore a handling system under inert gas atmosphere without moisture and oxygen is necessary and typical one of such systems is a glove box.

Our glove box system was constructed considering following conditions.

- a. In the process from sample preparation to measurement, we can always handle a sample in inert gas atmosphere such as Ar or He.
- b. The glove box system is composed of several main-rooms whose purpose and grade is different each other.
- c. Each mainroom is effectively connected with each other through subrooms.
- d. Provision of the gas purification unit.
- e. Easy manipulation of the system.

A rough sketch and a photograph of the glove box system are shown in Fig.4 and Fig.5, respectively and piping and instrument diagram is shown in Fig.6. Our glove box system is composed of four mainrooms, three subrooms, gas purification unit, gas exhaust and introduction unit and connected to the electron beam welding equipment.

R-1: The purpose of this room is setting of a sample on a holder for measurement under inert gas. Usually, the subroom(SR-1) is about 0.4m long but we can make it more than 1m long for a long holder (SR-1'). When a holder can not be laid horizontally, can be inserted here from the upper part.

R-2: This is the central room of the glove box system and is connected to R-3 and R-4 through SR-2. R-2 is also connected to the electron beam welding equipment and R-1. If one would like to seal some unstable material in a crucible, he can achieve it using this room. Usually an unstable material has been kept in an evacuated or Ar filled capsule. The capsule is broken and open in R-2 under Ar gas atmosphere and the material is put into a crucible. Then the crucible is transferred to the welding room of the electron beam welding equipment which is also filled with Ar

CRYSTAL GROWTH OF RARE EARTH COMPOUNDS IN CLOSED SYSTEM

- gas. Finally, one can seal the material in the crucible without exposing to the air. The door between R-2 and R-1 is very large (about 400mm diameter). Therefore if one needs large main-room, he can have large room(R-1 + R-2) by opening this door. This room is furnished with an optical microscope for the observation and measuring the size of the sample.
- R-3: This room is used for the dirty work which contaminates the atmosphere of the room, that is cutting, polishing etc. Therefore the size of this room is small compared to the other rooms and so one can exchange dirty gas to clean one immediately. The small size of this room also leads to low running cost. The window of this room is very large to perform such a work easily.
- R-4: This room is furnished with a lathe and a balance, and using them in the inert gas atmosphere preventing oxidation. A rare earth metal ingot is made to chips using this lathe. The lathe is also used to take out sample from a crucible using very hard ceramic tools.

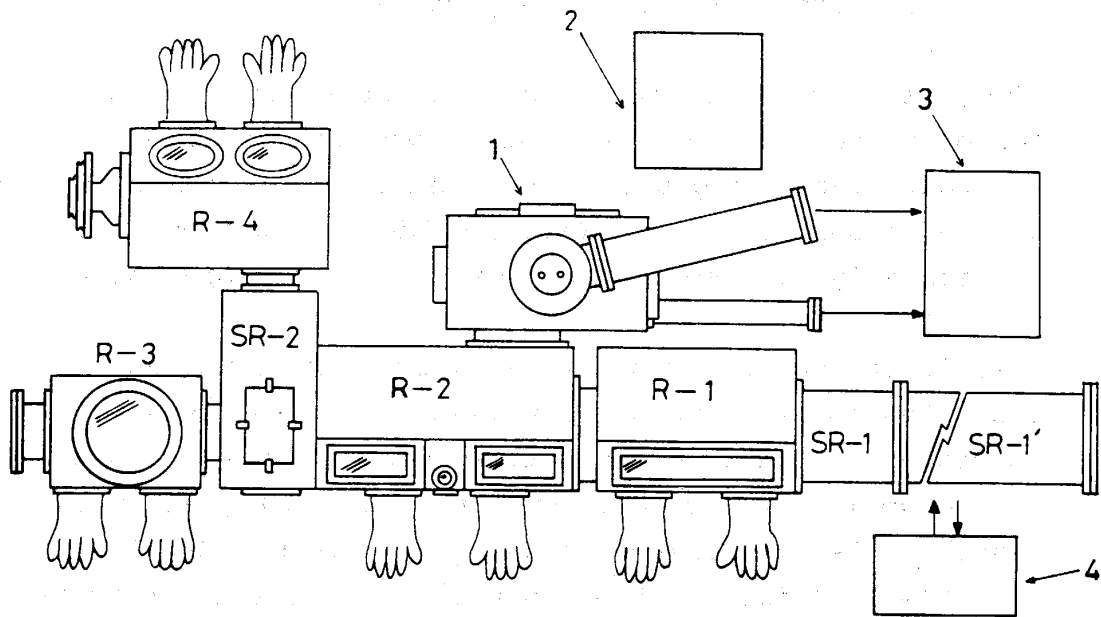

Fig.4 Sketch of the glove box system for sample preparation and attachment to sample holders.

- 1; electron beam welding equipment
- 2; power controller
- 3; vacuum unit
- 4; gas purification unit

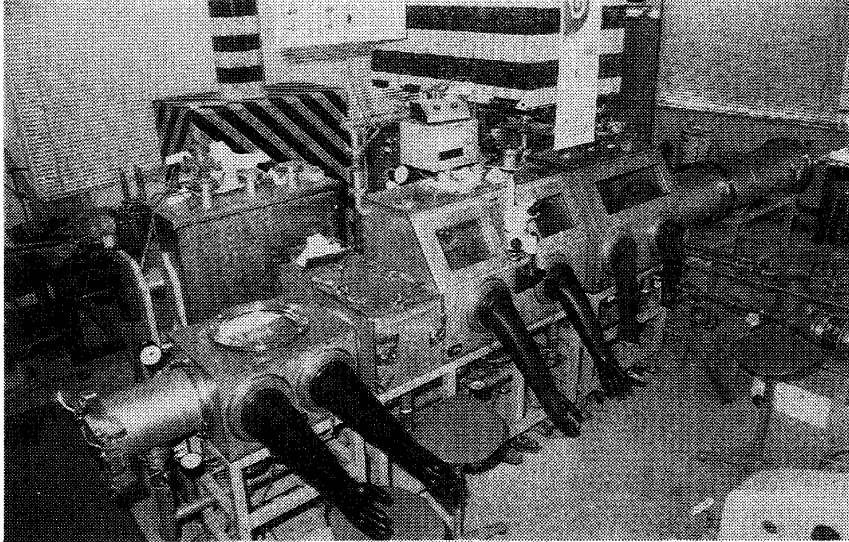

Fig.5 Photograph of the glove box system.

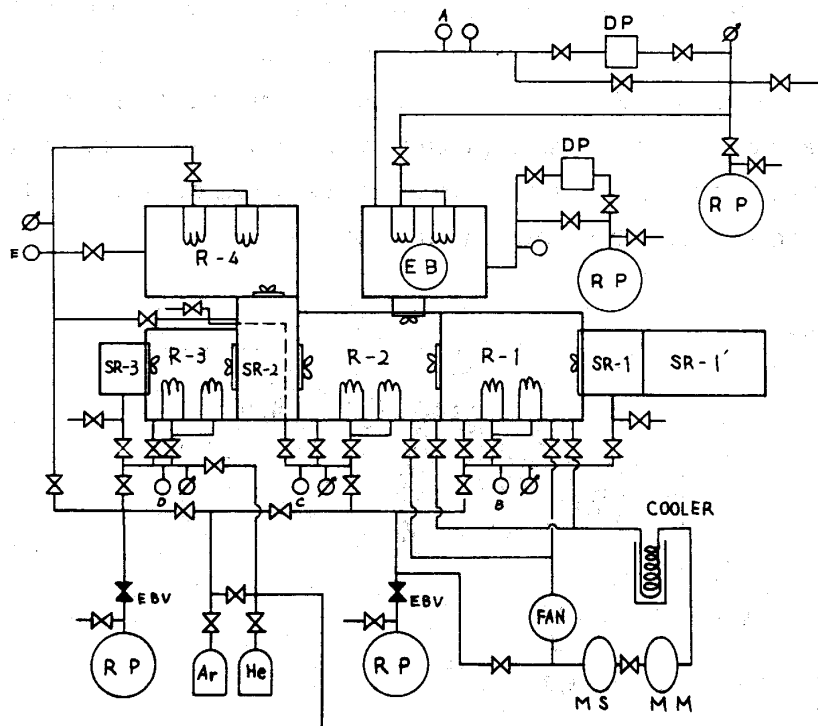

Fig.6 Piping diagram of the glove box system and electron beam welding equipment.

- R.P. ; rotary pump
- D.P. ; diffusion pump

CRYSTAL GROWTH OF RARE EARTH COMPOUNDS IN CLOSED SYSTEM

E.B. ;	electron beam welding equipment
E.B.V. ;	electromagnetic valve manipulated by foot
A.B.C.D.E ;	measuring point of vacuum
;	vacuum guage

Gas purification unit:

This unit circulates and purifies the inert gas of R-1 and R-2. First moisture of the dirty inert gas circulated by the fan is removed by the molecular sieves and then oxygen is eliminated by the misch metal which is heated at about 500°C. After that the gas is cooled by water in the heat exchanger and returned to R-1 and R-2.

Gas exhaust and introduction unit:

The gas in R-1, R-2 and R-3, R-4 are exhausted by the rotary vacuum pump RP-2 and RP-3, respectively. The degree of vacuum of each room is monitored by Pirani vacuum gauge. We can use either Ar or He gas, however if one select either of them, the user of the other room except R-3 must use the same gas. As shown in Fig.5 and Fig.6, some of valves are electric ones because of easy manipulation, and they are controlled by each foot-switch and their action is monitored by lamps on the panel as shown in the photograph of Fig.7.

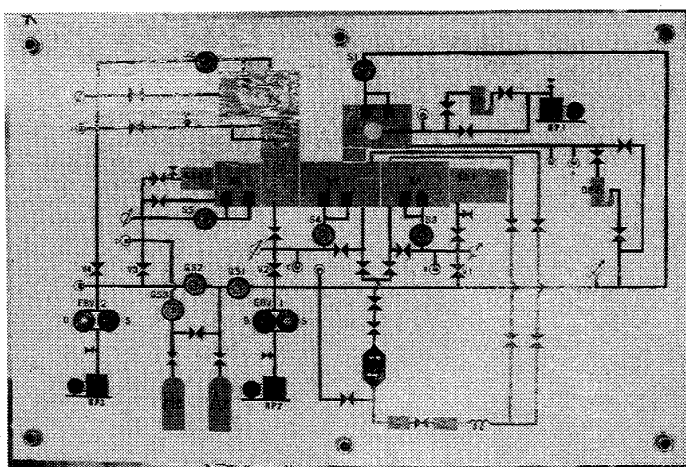

Fig.7 Photograph of the piping panel

Glove:

To evacuate the main-room, a cap is necessary to each glove. There are two ways to cover the cap on the glove, one is to cover the cap from outside and another is from inside. Here, we select the inside cap and the reasons are as follows.

- a. The transmission of moisture and oxygen through the glove is a critical problem, and to prevent the contamination of the inert gas of main-room, the inside cap is preferable.
- b. When the glove box is not used, the glove is expanded with the inert gas. Therefore if there is a defect of the glove, we can find it immediately.

Here, we try a thinking experiment that is preparation of SmS using the glove box system. This seems to explain effectively how to use the glove box system.

1. Sm metal, sulfur, a quartz tube which is already manufactured to use and a balloon are put in SR-2 and then the air in SR-2 is exchanged with Ar gas.
2. Sm metal etc. are transferred to R-4 which is filled with Ar gas.
3. Sm metal is made to small chips using the lathe. Sm metal chips and sulfur are taken weight and put them in a quartz tube.
4. The balloon is put on the quartz tube as shown in Fig.8. Then it is transferred to SR-2 and taken out from the glove box system.
5. The quartz tube is evacuated and sealed in the outside. Then the pre-reaction is performed in a proper conventional furnace.
6. After pre-reaction, the sealed quartz tube is brought to R-2 through SR-2.
7. In R-2, the sealed quartz tube is broken and the pre-reacted powder is transferred to a W crucible.

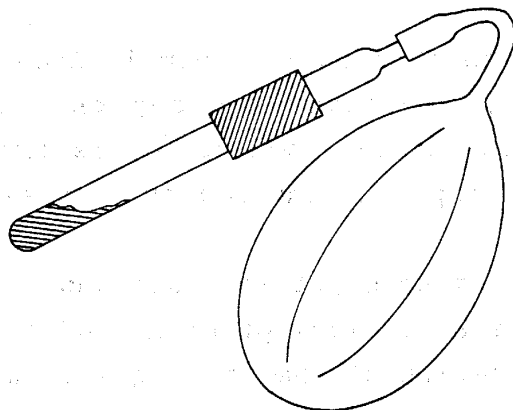

Fig.8

Balloon and a quartz ampoule or a glass ampoule. A sample is put into the ampoule in the glove box with Ar gas atmosphere and taken out. At first the neck of the ampoule is narrowed by flame, then evacuated and sealed.

8. The W crucible is transferred to the welding room of the electron beam welding equipment filled with Ar gas, too.
9. The crucible is sealed in vacuum and brought out from the welding room.
10. The W crucible is set in a proper high temperature furnace for crystallization.
11. After crystallization, the W crucible is brought to R-4 through SR-2 and the crystal is taken out from the crucible using the lathe.
12. Observation by the microscope.
13. X-ray diffraction by Gandrfy Camera.
14. Sample attachment to certain holder for several measurements in the glove box. When some complicated operation is needed in the preparation of measurement and that is very difficult to perform in the glove box, the sample is coated with manicure in the glove box and taken out, then the preparation is performed in the air. This can be a simple and convenient method.

15. The crystal is preserved in an evacuated sealed glass tube.

6. Furnace

6-1 Vacuum furnace with tungsten heater

The vacuum furnace with tungsten heater is much convenient to operate below 2000°C and has a great stability of the temperature within ± 1 degree/hr at 2000°C. The construction of this furnace is shown in Fig.9. There are two kind of W heater available as shown in Fig.10, mesh heaters and plate heaters. The mesh heater is superior to the plate one in its thermal stability. The plate heater is rather easily deformed by the recrystallization of W especially in the operation near 2000°C. On the other hand, the mesh heater deforms little for long time operation near 2000°C. The radiation shield is consisted of W, Mo and Ta plates. They are also deformed by heating near 2000°C. So it is practically better to operate this type of furnace below 2000°C for economical reason. The temperature is measured by W-Re thermocouple which is very stable in vacuum below 2000°C.

Typical temperature profile of this furnace is shown in Fig.11. By the way temperature gradient is variable when two mesh heaters are provided with this type of furnace. A crucible is vertically set on the top of long rod with screw which is vertically travelled by the external force in Bridgman method. This rod is made of double pipe of stainless steel for water cooling, and a short rod of Mo is mounted on it to connect with the crucible. An additional BN rod is sometimes inserted between these rods as a thermal insulator to reduce the temperature gradient at the bottom of the crucible. This furnace is quite useful for us to grow various crystals by Bridgman method or the other method below 2000°C. The details of the crystal growth method and physical properties of the crystals made by it shall be described in later chapter.

CRYSTAL GROWTH OF RARE EARTH COMPOUNDS IN CLOSED SYSTEM

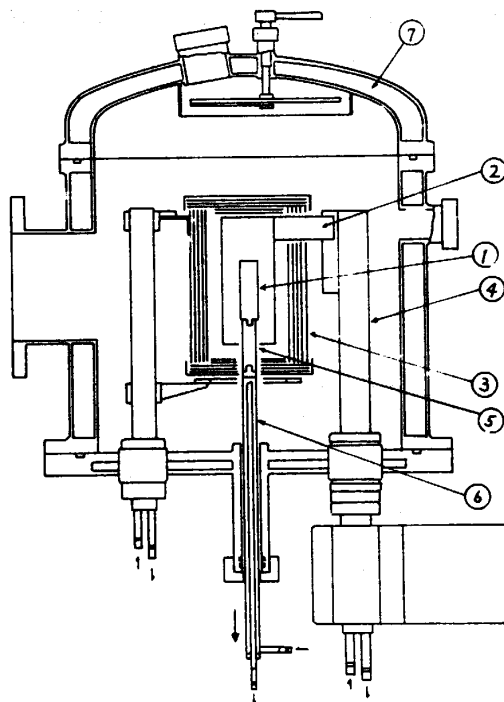

Fig.9 Construction of the vacuum furnace with a tungsten heater.

- | | |
|---------------------|---------------------|
| 1. crucible | 2. tungsten heater |
| 3. radiation shield | 4. electrode |
| 5. Mo rod | 6. water cooled rod |
| 7. water jacket | |

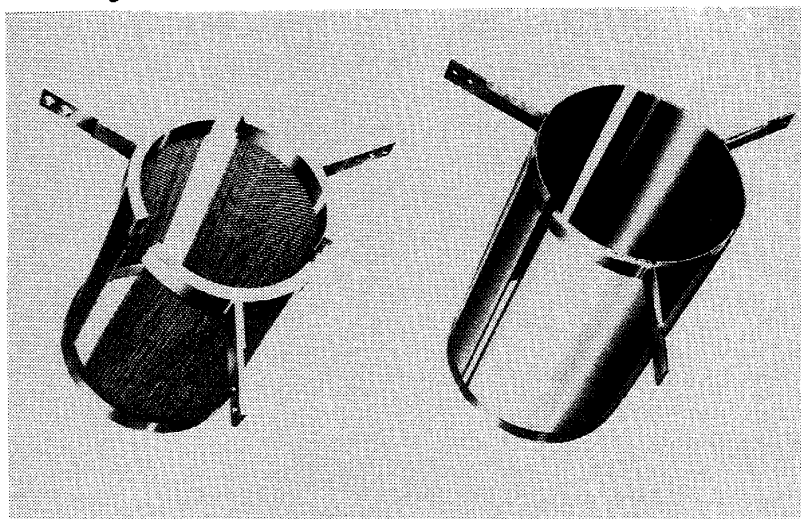

Fig.10 A tungsten mesh heater and a tungsten plate heater

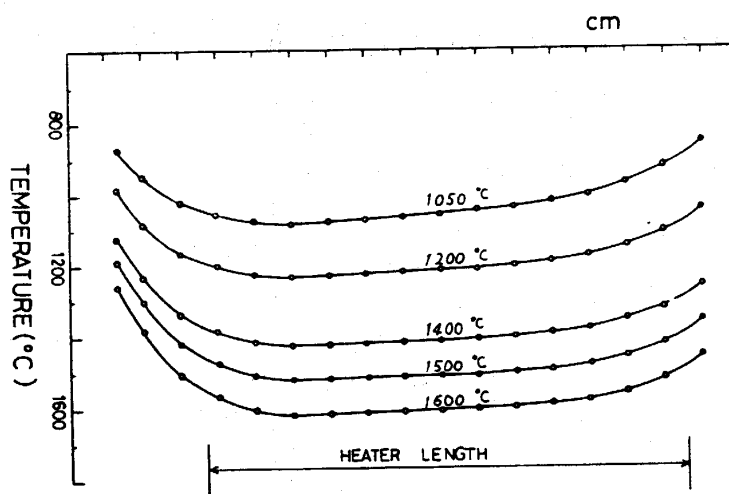

Fig.11 Typical temperature profile of the vacuum furnace with a tungsten plate heater

6-2 Vacuum furnace heated by high frequency (HF) induction

Above 2000°C we cannot practically use the W-heater type furnace as just mentioned above. Several efforts have been made to obtain a stable furnace for such a high temperature. For example a furnace with a carbon resistance heater was developed. This furnace has however two disadvantages⁽⁷⁾: The introducing of high pressure Ar gas atmosphere (several ten or a hundred atm) to prevent the rapid evaporation of the graphite heater causes a large local temperature fluctuation around the crucible by its strong convection. Furthermore the graphite furnace cannot be practically used above 2500°C since the heater element becomes lean severely. Another variation of this type of furnace were also tried that is vacuum type one to avoid the convection of the gas and heated by HF induction coupling with carbon tube covered with heat insulating graphite felt. But this was not succeeded by nearly same reason just mentioned above. As the result a HF vacuum furnace with direct coupling with a refractory metal crucible is considered more preferable and has been developed. It can be used for the temperature up to 3000°C when a HF generator of 50kW is provided with. The typical

construction of this furnace is shown in Fig.12. The shell of the

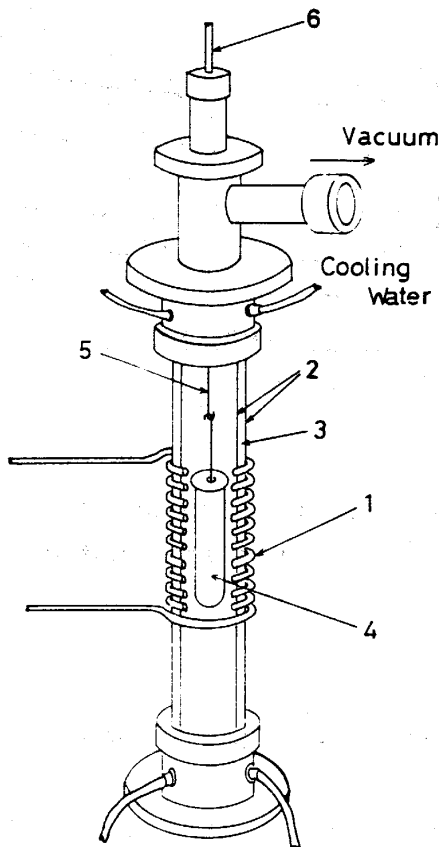

Fig.12 Construction of the vacuum furnace heated by high frequency induction.

1. H.F. coil
2. quartz tubes
3. cooling water
4. W crucible in a PBN radiation shield
5. W wire
6. travelling rod

furnace is consist of double silica tubes (70mm ϕ outside) and cooled by the water that flows between these tubes. A metal crucibles is hung from the top of the furnace by W wire. Inside of the inner silica tube is vacuumed by a mercury diffusion pump which can work strongly even in low vacuum. The temperature is measured by pyrometer from the top or the bottom of the furnace because inner surface of silica tube near the crucible is tarnished by the evaporation from the surface of the crucible element. The temperature profile can be changed by proper

adjustment of each interval of HF coil and measured by W-Re thermocouple clad with another earth line inserted with rather small capacitance ($0.1\mu\text{F}$) by which HF induced current is filtered. However this is possible only below 2400°C for its thermal stability. Above this temperature we can only estimate from electric power consumption of HF coil by extrapolation method. It is better to wind the HF coil a little bit wider in lower part of the coil to avoid steep temperature gradient at the end of the coil. The Bridgman method for crystal growth has been carried out by moving slowly downward the hanging crucible. Several other methods of crystal growth have been also done in this furnace, such as high temperature sublimation, chemical transport and recrystallization method. The detailed results shall be described in later section.

It is desirable to shield the radiation from heated crucible coupled directly with HF power, because strong radiation loss from the surface of the crucible must be made some temperature gradient on the horizontal plane in the crucible which does not give good influence for large single crystal growth. Another advantage of the radiation shield is to enable us to operate the furnace by rather small HF power in stable. Several efforts to make a radiation shield from carbon fiber were done. But even newly developed one was not useful by the reason as mentioned above. However we have found pyrolytic BN is very preferable for such a radiation shield. Pyrolytic BN is transparent for radiation in itself but can partly diffuse reflection by its random mosaic structure. However we can stick a thin tungsten layer on the inner surface of cylindrical BN by evaporation from W crucible in vacuum heating and it completely stands as a radiation shield for such a high temperature. Radiation loss and temperature gradient on the horizontal direction should be much reduced by adoption of three walls of the cylindrical BN with thin layer of tungsten as shown in Fig.12. As the results the additional problems that is fine boiling phenomenon in the cooling water in double silica tube caused by radiation and adhesion of tungsten layer on the surface of the inner silica tube which is tedious to remove every time are dissolved. Details are reported in another paper⁽⁸⁾.

6-3 Hot Isostatic Pressing (HIP) furnace

This furnace have been spread by industrial needs and available up to the temperature of 2000°C and the pressure of 2000 atm by argon or nitrogen gas. The construction is shown in Fig.13. Temperature is measured by W-Re thermocouple. Homogeneity of the temperature in this furnace is rather well because of the strong convection of high pressurized gas. Available volume as sample space is 10cm-dia and 15cm length. We have noticed the ability of this furnace and applied it to sample preparation. Pre-reactions under high pressure of chalcogenides and pnictides are available by this furnace as mention before. This furnace is suitable to synthesize rare earth nitrides by direct reaction between rare earth and pressurized nitrogen gas itself in the chamber.

The establishment of stoichiometry of nitrogen compounds can be attained by the proper selection of the pressure of nitrogen and the temperature of the furnace. For example synthesis method of CeN is shown in Fig.14. In this process, we use a special capsule to prevent the invasion of impurities from the gas as shown in Fig.14. The capsule has two reaction chambers and both filled with Ce metal chips. The Ce metal in the front chamber has a function as an adsorbent of impurities and protect the main chamber from contamination. This capsule seems effective because after the reaction the color of these two chambers is clearly different. After these pre-reaction, sample is sealed in a tungsten crucible and turn into a single crystal by Bridgman, sublimation or other crystalization methods.

6-4 Three zone furnace for chemical transport method

A three zone furnace is constructed. The details are described in chapter 8-3.

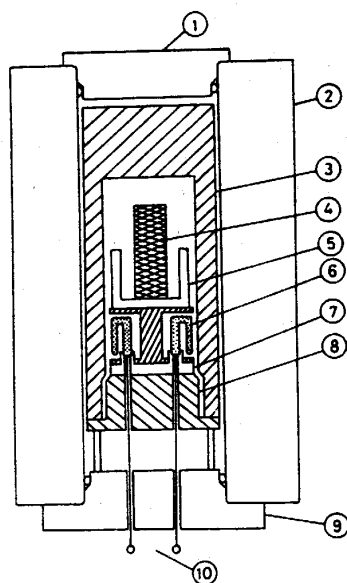

Fig.13 Construction of the hot isostatic pressing furnace

- | | |
|----------------------|----------------------------|
| 1. lid | 2. shell with water jacket |
| 3. heat shield cover | 4. ampoule |
| 5. ampoule holder | 6. carbon heater |
| 7. heat shield | 8. heater support |
| 9. bottom lid | 10. electrode |

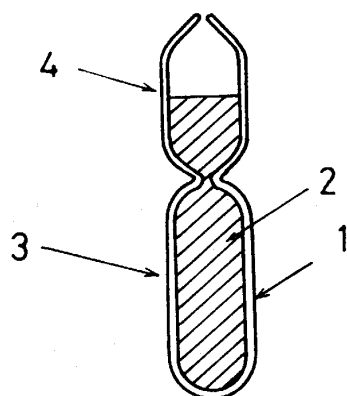

Fig.14 Quartz ampoule for synthesis of CeN. Ce metal chips in the front chamber react with or absorb impurities in nitrogen gas and prevent the main chamber from the contamination.

- | | |
|-------------------|-------------------|
| 1. quartz ampoule | 2. Ce metal chips |
| 3. main chamber | 4. front chamber |

7. Electron Beam Welding System

Encapsulation of a metal crucible by welding is an important process in our crystal growth procedure. We welded metal crucibles by usual electron beam melting equipment (Acceleration voltage 5kV, Beam current 500mA). But its capability was limited to only welding of Mo crucibles and specially thin and quite expensive W crucibles because of its weak focusing. The quality of a single crystal grown in a Mo crucible is usually not so good because of the reactivity of Mo.

The electron beam welding system which is newly constructed by us is schematically shown in Fig.15. The upper part of this figure is electron beam gun consists of direct-heat type tungsten ribbon cathode of 3x3 mm and anode with small hole of 5mm ϕ . The middle part is made of two magnetic lenses act as focusing and deflecting electron beam respectively. The lower part is a crucible supporting table with a water cooled copper hearth which is able to rotate and shift in basal plane by external handling. Between the gun and the lower part there is an isolation valve which makes each part vacuum independently and maintains clean state of the gun. This equipment is directly connected with the large glove box for multi-purpose and we can transfer crucibles or samples without exposing in the air from the glove box to this welding system through the vacuum tight door. The connected systems are schematically shown in Fig.4.

The power source is capable to supply the maximum acceleration DC voltage of 60kV and maximum beam current of 120mA respectively within 0.1% fluctuation. And we can perform many operations from the control panel such as location of the electron beam spot on the welding part of a crucible by magnetic lens and adjusting the beam power just watching the bombardment on the crucible through the lead glass window. The exterior view of this system is shown in Fig.16. Thus we can get satisfactory results of welding W crucibles in very short time of typically 30 sec without escaping of the sample by evaporation, which is considered to be important to improve the quality of crystals as mentioned later. We could weld W crucibles made by ourselves of rather low cost instead of very expensive commercial one with thin wall. This is very important point for us to research much more compounds within the limited budget. Typical example of a W crucible welded by us is shown in Fig.17. The acceleration voltage is 50kV and the beam current is 60mA in this case. Another advantage of this system is we can encapsulate a sample in a very thin and small Ta or W container by

welding in very short time without evaporation. This is very important in the case of measuring differential specific heat in thermal analysis for establishment of the phase diagram in research of new rare earth compounds. In this case, welding should be carried out under

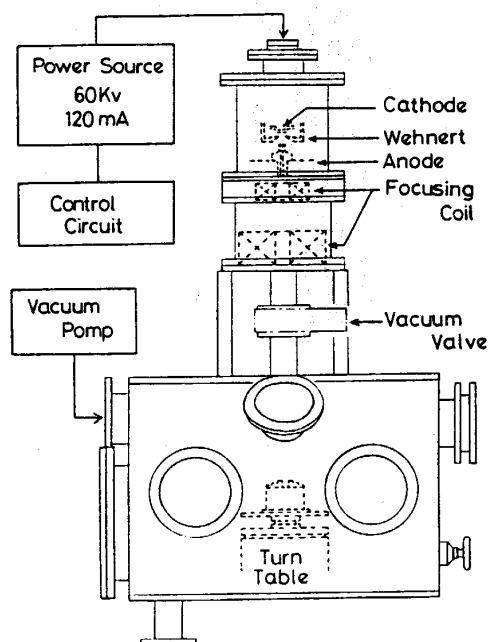

Fig.15 Construction of the electric beam welding equipment

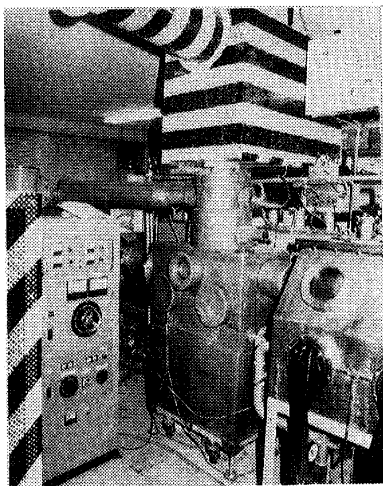

Fig.16 Photograph of the electric beam welding equipment

extremely focused condition applying large wynert voltage in highest acceleration voltage in this system. The beam diameter is about 0.1mm and the welding condition is 60kV, 10mA and 80mm/min. for welding a W crucible with 0.1mm thickness.

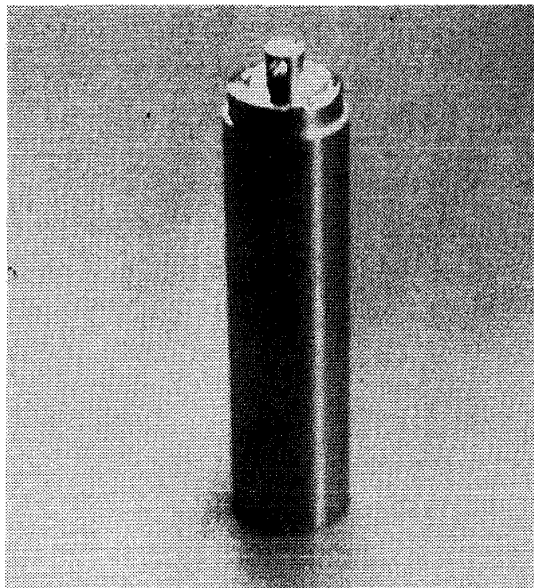

Fig.17 Photograph of a tungsten crucible welded by the electric beam welding equipment

8. Crystal Growth of Rare Earth Compounds and Their Physical Properties.

8-1 The 1:1 compound of rare earth pnictides and chalcogenides

These compounds are almost congruent materials and have high melting temperature from 2000 to 3000°C. For example mono Bismuthides and mono tellurides of rare earth metals have their melting point around 2000°C, on the other hand those of Nitrides are near 3000°C. Up to now several attempts to grow these crystals have been done. The recrystallization method of keeping the crucible temperature just below the melting point of the compound has been applied to Antimonides, Bismuthides and Arsenides of rare earth and Uranium by Vogt et al⁽⁹⁾. Vapor growth of Sulfides and Phosphides has been developed successfully by Kaldis⁽¹⁰⁾. We have employed the melt growth by Bridgman method for all pnictides and chalcogenides. This method is possible to supply a large single crystal for neutron diffraction. One of the most severe check of the quality of an obtained single crystal is whether the detection of the signal of dHvA effect is possible or not. We shall show the typical example of CeSb. We have succeeded to observe the dHvA effect on a single crystal

of CeSb grown by HF furnace under Ar gas atmosphere using a Mo crucible in 1980⁽¹¹⁾ for the first time as shown in Fig.18. Only three branches can be observed and they are considered to correspond to hole and electron Fermi surfaces. After this, the effort to detect other Fermi surfaces has been made by both our group and Argonne group independently with more extended magnetic field up to 13T and lower temperature down to 0.5K. Just same result was obtained by both group as shown in Fig.19^(12,13). At this time, very serious discussions are occurred between Sendai theoretical group and Argonne group. Sendai group argued that there should be another undetected branch from their band calculation taking account of many body interaction of f electron⁽¹⁴⁾. Argonne group opposed this argument based on their usual band calculations⁽¹⁵⁾. The continuous endeavors for search of the existence of the undetected branch in dHvA effect have been done by our group in mainly following two improvements. One is to get more superior quality of the single crystal. Most important improvements in the procedure of crystal growth are the construction of the genuine electron beam welding system with large glove box for multi-purpose and improvement of the stability of the temperature in the furnace as mentioned above. Up to 1983 we used the HF furnace under high pressure Ar gas atmosphere which was constructed for crystal growth of rare earth hexaborides by floating zone method. There Ar gas prevents the evaporation of a sample during floating zone process. However if we applied Bridgman method in this furnace, strong convection of Ar gas brought temperature fluctuation around a crucible. So we constructed another vacuum type HF furnace as shown in Fig.12. Thus the stability of the temperature has been improved remarkably. Another is the extension of measuring temperature region of dHvA effect down to 20mK. Then recently we have succeeded to observe the new branch of the Fermi surface in CeSb and justified the rightness of the argument of Sendai theoretical group through those improvements just mentioned above⁽¹⁶⁾. Thus we could also observe and determine the Fermi surfaces of Antimonides and Bismuthides of La and Ce by similar way.

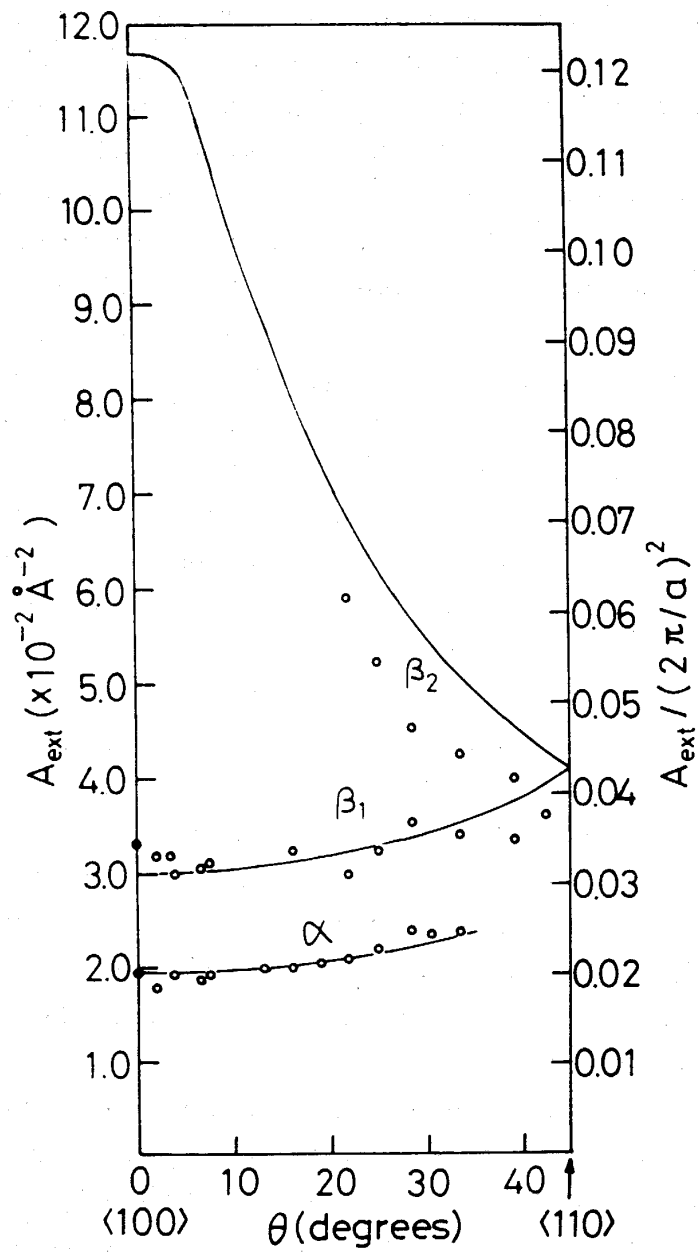

Fig.18 dHvA effect on the single crystal of CeSb by the HF furnace under Ar gas atmosphere using a Mo crucible in 1980.

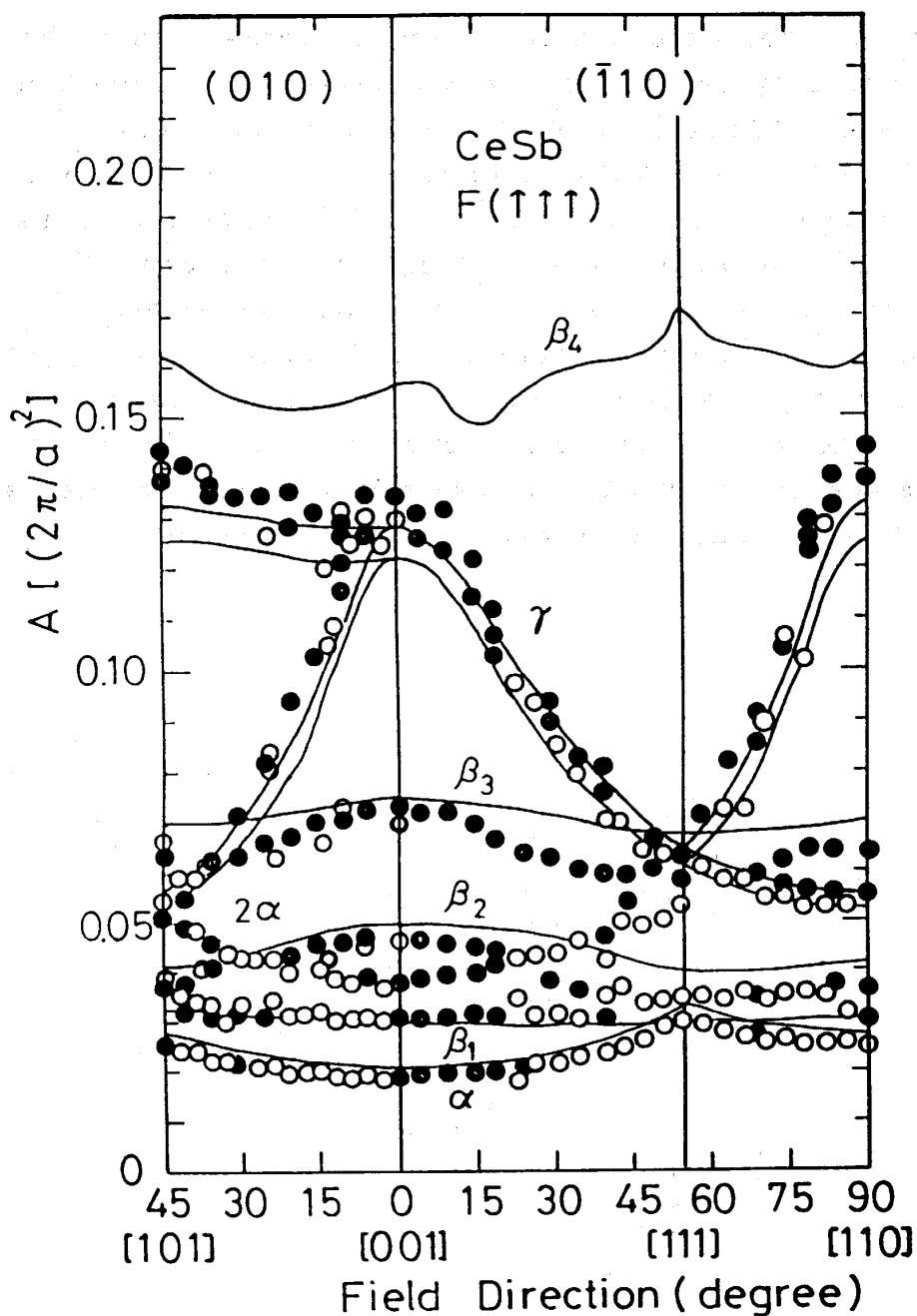

Fig.19 Observation of dHVA effect on the single crystal of CeSb by Sendai group and Argonne group.

° by Sendai group

• by Argonne group

The melting points of Phosphides and Arsenides are higher than Antimonides and Bismuthides. It is rather difficult to get stable, homogenous and so high temperature. If we increase the high frequency

power to heat up, the radiation loss also increase. Then the radiation shield is essentially important. We discovered the excellent material of Pyrolytic Boron Nitride (PBN) mentioned before, which is the best radiation shield so far. This discovery is very valuable in practice and contributes to ultra high temperature technology. Thus we could make a very stable and homogenous temperature around 2500 °C. This improvement have made our crystal growth of Phosphides and Arsenides possible. And now we can make excellent and large single crystals. For example, recently we could detect the dHvA signal of YbAs.⁽¹⁷⁾ Astonishingly, the signal can be detected even at 1.3K which is higher than Neel temperature of 0.6K, and the signal amplitude decreases with decreasing the temperature from 1.3K on the contrary to usual case.(Fig.20)

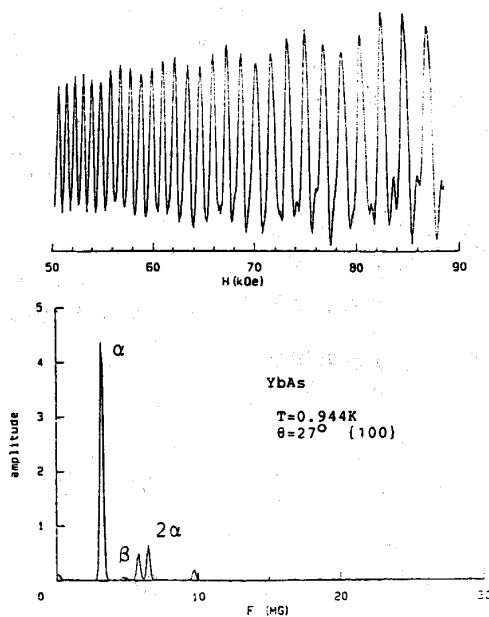

Fig.20 DHvA signal of YbAs at 0.944K and its Fourier transform.

In fact, Yb-monopnictides are thought to be heavy fermion systems. Fig.21 shows the broad maximum of specific heat of YbP which is ascribed to Kondo effect. All Yb-monopnictides have almost the same maximum around the same temperature range. And the characteristic feature of

these systems is the temperature dependence of the entropy. (Fig.22) All entropy of ground states is released around 20K, which is much higher than Neél temperatures. T_N of these systems are below 1K.

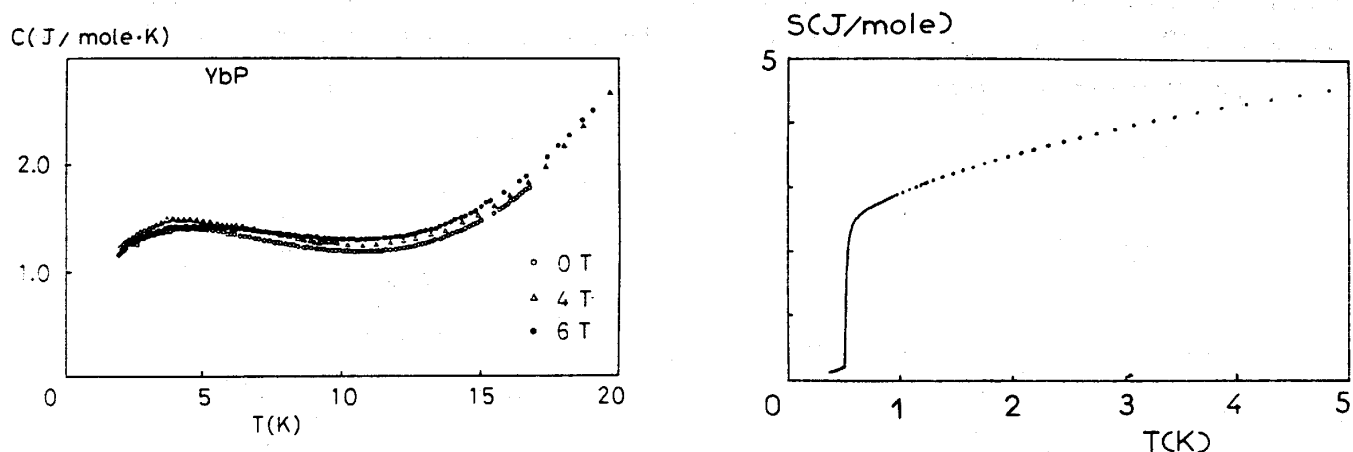

Fig.21 The temperature dependence of the specific heat of YbP (left)

Fig.22 The temperature dependence of the entropy of YbAs (right)

Fig.23 shows the magnetoresistance of YbAs. This shows the typical semi-metallic behavior. This means the stoichiometry of this sample is rather good.

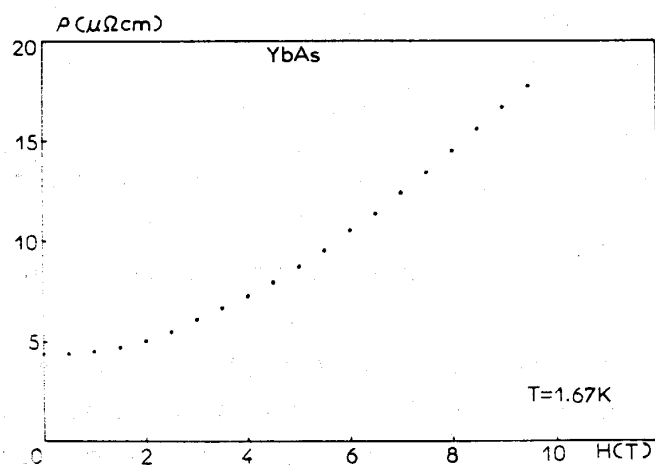

Fig.23 The magnetoresistance of YbAs up to 10T.

Furthermore, we could make large enough single crystals of YbAs and YbP to measure neutron scattering experiments. We could determine the magnetic structure of YbAs. (Fig.24)⁽¹⁸⁾ Fig.25 shows the inelastic scattering of YbP. Surprisingly, magnetic response with q -dependence still exists around 100K. This means there is magnetic correlations around 100K though T_N is below 1K. This seems quite interesting feature of heavy fermion systems.

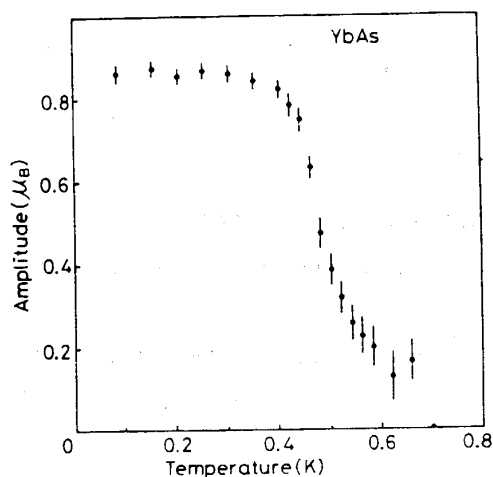

Fig.24 The temperature dependence of the order parameter of YbAs. (left)

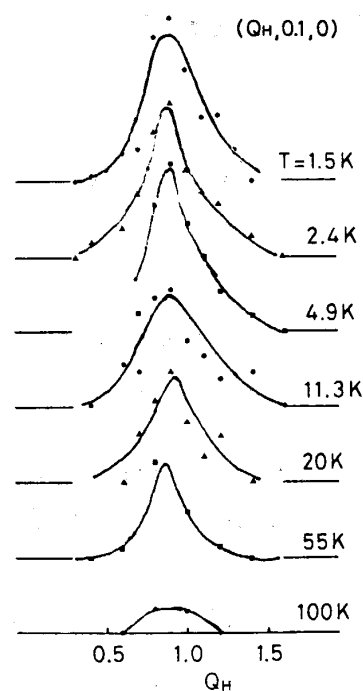

Fig.25 The q -scan of inelastic neutron scattering of YbP (right)

The melting points of arsenides and phosphides are much higher than those of antimonides and bismuthides as mentioned before. So the crystal growth becomes difficult. Typical example of this difficulty have been shown by F. Hulliger et al. on CeP and CeAs. It is clear that the sample dependence of several physical properties are fairly large as shown in fig.26 and fig.27.

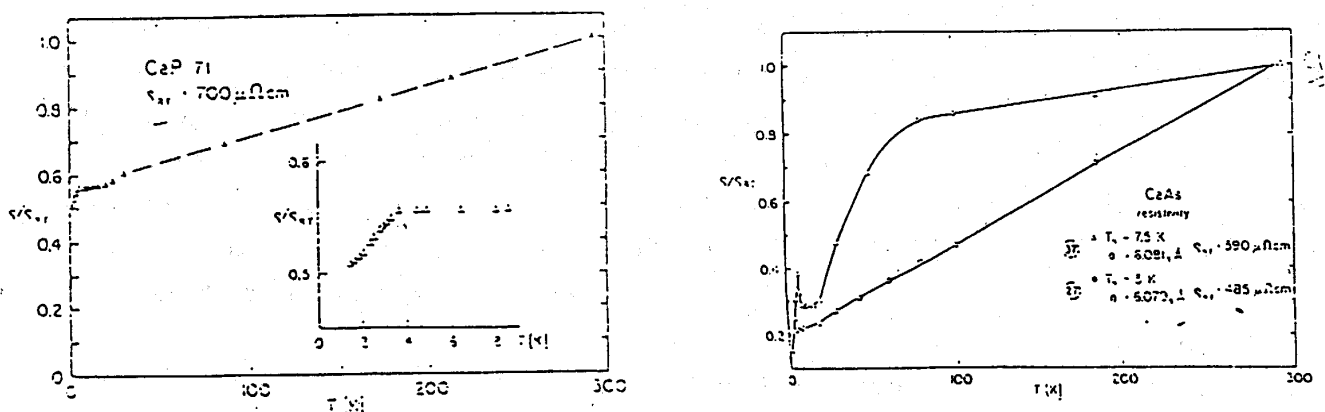

Fig.26 and 27 The temperature dependence of the resistivity of CeP and CeAs by F. Hulliger et al.

After their work, no more people have challenged to grow good single crystals for obtaining reliable results.

However we recently considered that their works are worth noticing as following reason. Why are there such large unusual sample dependences? It suggests that the systems are low carrier semimetals. In fact, in the series of Ce-monopnictides, CeP and CeAs are expected to be semiconductors or semimetals with very small overlapping between conduction bands and valence bands from theoretical works by A. Hasegawa. So we thought that these compounds have possibilities to be typical examples of Kondo systems with extremely low carrier concentration. Then we started to obtain good single crystals. The most important work is to control the stoichiometry. The effort to establish the stoichiometry was not described in Hulliger's paper. They have tried two different methods, sublimation and recrystallization around 2000 °C. However 2000 °C is not enough to get large crystals. The most suitable temperature is just below melting temperature for recrystallization process. The melting temperature of CeP and CeAs is about 2500 °C. Now we can handle such high temperatures above 2000 °C as mentioned before. Next serious problem is how to control the stoichiometry of CeP and CeAs in such a high temperature region. This situation is the same as that of Yb-monopnictides. Unfortunately we did not know the complicated situation of these compounds in such a high

temperature. For example, there is no data for vapor pressure of pnictogen around 2500 °C and we do not know whether these compounds have congruent vaporization or not. Furthermore the vapor of pnictogen shall react with the surface of tungsten crucible to make WP. The equilibrium states of these compounds in tungsten crucibles are beyond our present knowledge so far. So it is necessary to do a lot of tries and errors to search for the most suitable condition to establish the best stoichiometry.

Finally we could get very good and pure crystal of CeP. Ce : P ratio of the starting material is 1 : 1.1 (sample 1). The lattice parameter 5.945 Å and Néel temperature 10K of our sample are the largest in the previous reports. The temperature dependence of the electrical resistivity is shown in fig.28. Overall feature is completely differ from the results of F. Hulliger et al. Schubnikov dHvA effect could be observed as shown in fig.29 and the carrier concentration is determined to be 0.001 / Ce.

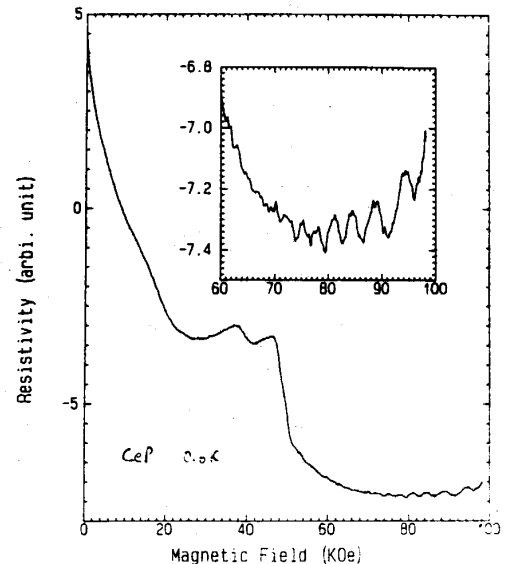
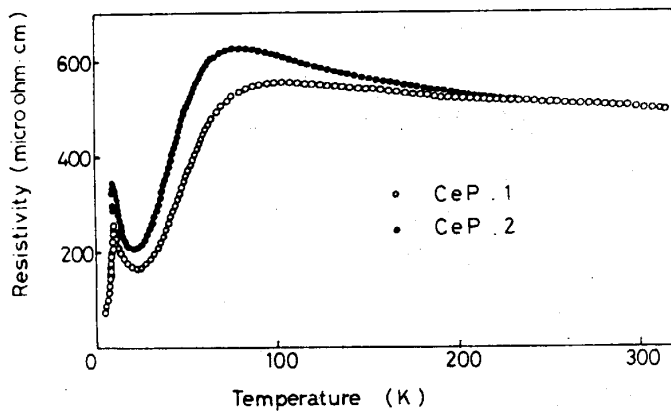

Fig.28 The temperature dependence the resistivity of CeP (left)

Fig.29 The SdHvA oscillation of CeP (right)

We could not observe Schubnikov dHVA oscillations of the crystal obtained from the starting material of which stoichiometry is 1 : 1 (sample 2) Magnetoresistance at low temperature show clear evidence of sample quality. Typical examples are shown in fig.30. Sample 1 shows typical behavior of compensated semimetal. This shows that the stoichiometry of this sample is rather good. In fact, the most important point now is the characterization of samples. This is generally rather difficult work. Especially, the estimation of stoichiometry is quite difficult though the stoichiometry is quite important for physical properties. Chemical analysis needs large amount of samples to have good precision. Our requirement is at least 1%. One of the trials is shown in fig.30. This is the neutron diffraction of the powder sample of YbN. The Rietveld analysis can give us the stoichiometry. However, the error bar is 4% ,which is rather large. This estimation of the stoichiometry is our futur problem.

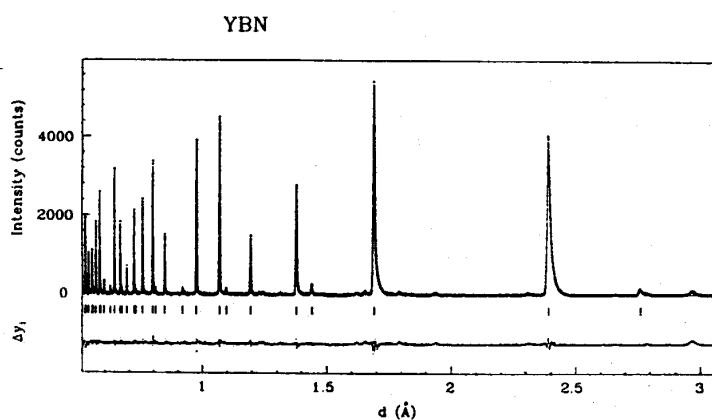

Fig.26 The neutron diffraction of the powder sample of YbN.

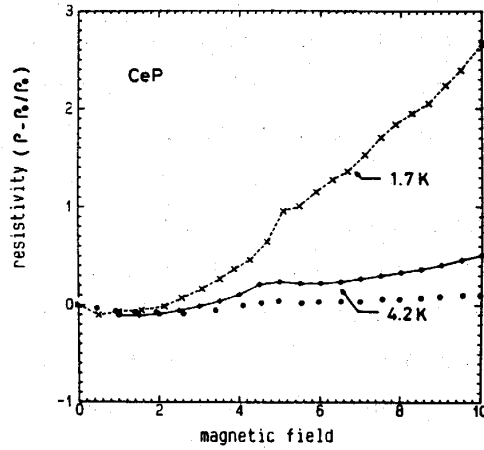

Fig.31 Magnetoresistance of CeP

We could get also very good single crystal of CeAs. Fig.32 showed the temperature dependence of resistivity.

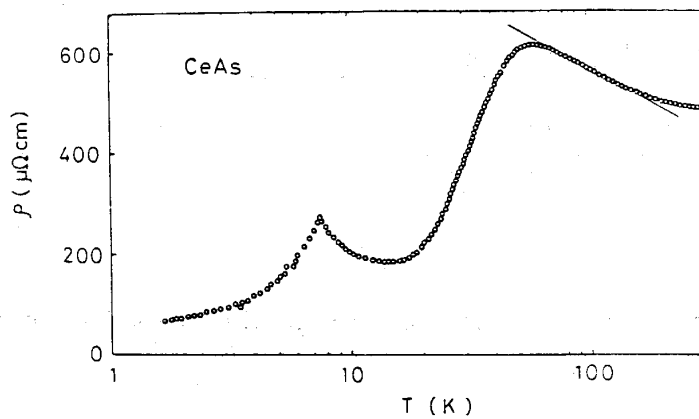

Fig.32 The temperature dependence of the resistivity of CeAs

The magnetoresistance and SdHvA oscillation are shown in fig.33 and fig.34.

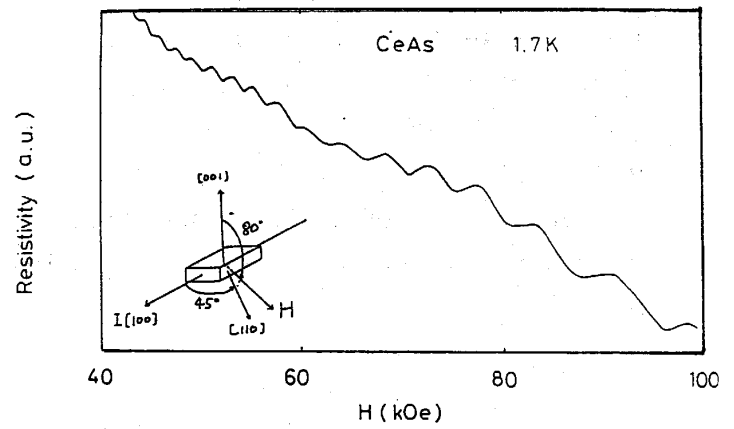
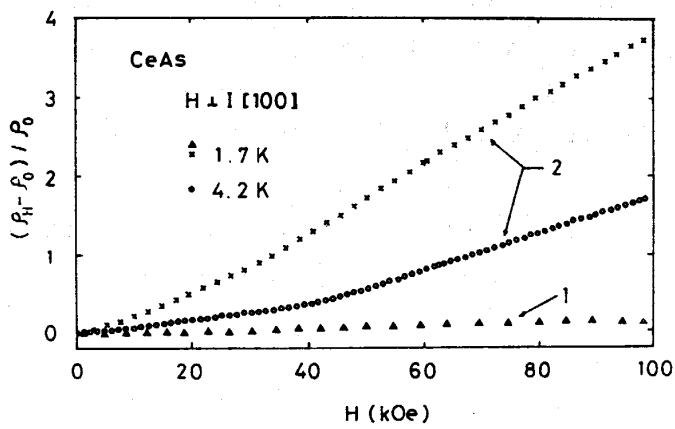

Fig. 33 Magnetoconductance of CeAs (left)

Fig. 34 SdHvA oscillation of CeAs (right)

After Fourier analysis, the obtained angular dependence of each Fermi surface are shown in fig. 35.

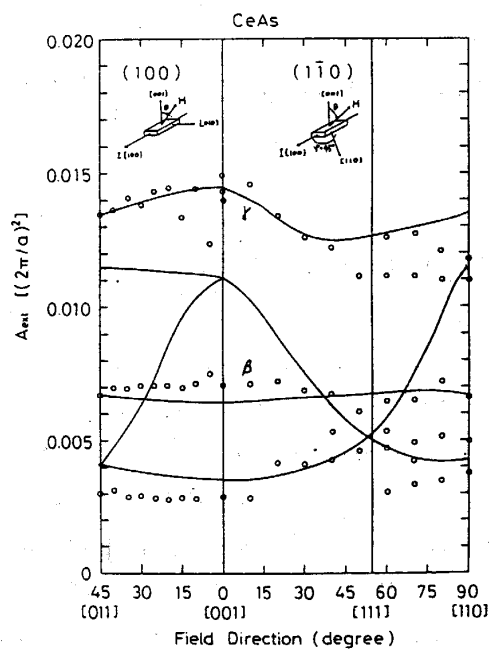

Fig. 35 The obtained angular dependence of each Fermi surface of CeAs

Kondo behavior in high temperature can be seen in fig.28 and fig.31 for CeP and CeAs respectively. Why do such a extremely low carrier system have Kondo behavior? It is a serious problem. The most serious and attractive phenomena is electronic specific heat. We can obtain γ value of $17 \text{ mJ} / \text{mol deg}^2$ from the data as shown in fig.35. The mass enhancement factor become extremely higher than other heavy fermion systems. These compounds may give us the new scope of heavy Fermion physics.

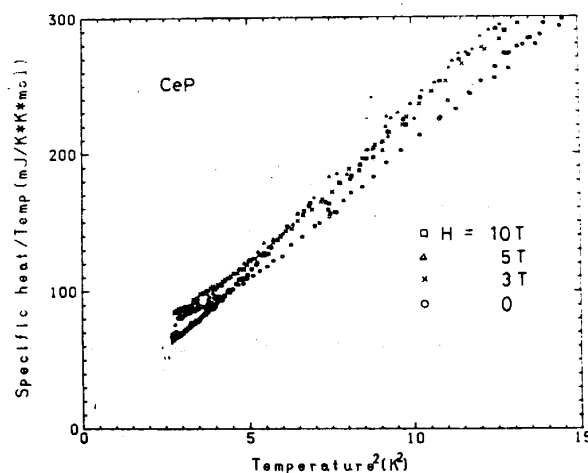

Fig.35 C/T vs T^2 plot of specific heat of CeP in magnetic field.

8-2. The Crystallization of the Incongruent Materials like Yb_4As_3

Another important benefit of the success of the construction of the electron beam welding system with multi-purpose large glove box is to enable us to use W crucibles easier and lower cost. If we challenge to explore for an unknown rare earth compound which has no phase diagram, we have to prepare a lot of W crucibles to estimate the proper temperature for crystal growth. This is especially true for incongruent materials. A typical example of our research is reported here in the case of Yb_4As_3 . In this compound only anti- Th_3P_4 structure phase was known. No single crystal and no physical measurement had been obtained. We initially found out this material is incongruent. We could successfully get the single crystal after several trials and error by our newly developed growth method. The key point of this method is to

change intentionally the composition of the starting material to Yb rich from its proper stoichiometry and to keep the temperature of the crucible just below the dissociation point of Yb_4As_3 for about one week. The rather large single crystal of Yb_4As_3 was obtained by segregation from the solution of off stoichiometry composition which may act as some kind of flux. The obtained crystal is shown in Fig.36.



Fig.36 Photograph of the single crystal of Yb_4As_3 obtained by segregation.

Here the crystallization of incongruent compound R_4X_3 as shown in the phase diagram Fig.21 is explained in detail. When one would like to obtain a single crystal of RX in the phase diagram of Fig.37, Bridgman method seems to be the best. But to obtain a single crystal of R_4X_3 , Bridgman method is unsuitable. If the stoichiometric composition of R_4X_3 is heated up to complete fusion and then gradually cooled, we get mixture of RX , R_4X_3 and R_5X_3 etc. If we start from the mixture of the $\text{R}_\text{Y}\text{X}_\text{X}$ and small amount of R , we get at first R_4X_3 . But to make it possible it is necessary to determine the exact composition of $\text{R}_\text{Y}\text{X}_\text{X}$. Further, in the case that the composition $\text{R}_\text{Y}\text{X}_\text{X}$ and $\text{R}_\text{U}\text{X}_\text{V}$ are very close to each other this method can not be realized.

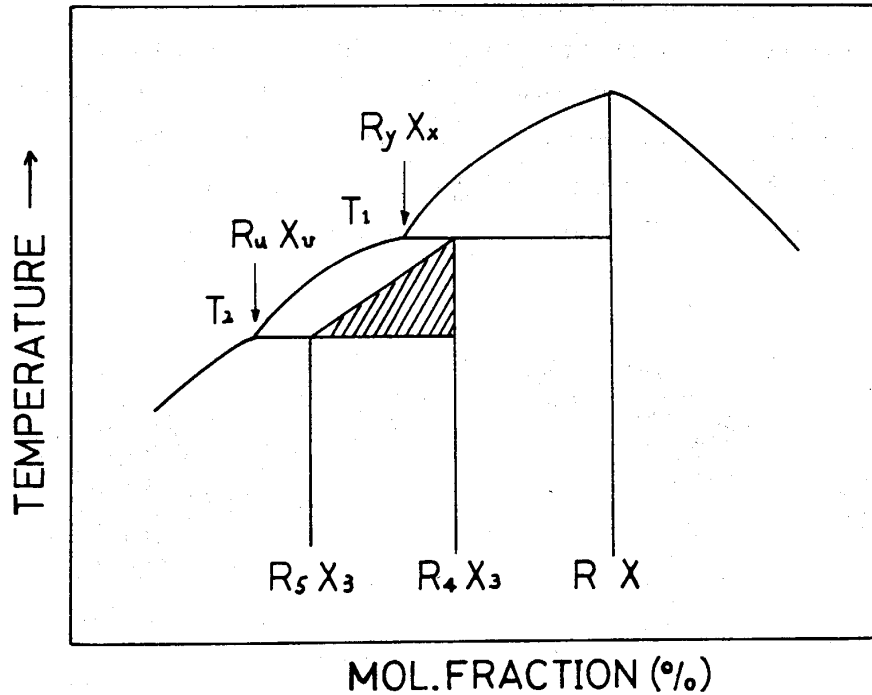

Fig.37 Conceptual phase diagram of the incongruent compound $R_y X_x$. In the triangular area which is determined by a few informations that is roughly estimated peritectic temperature T_1 and T_2 and the composition of $R_4 X_3$ and $R_5 X_3$, crystallization of $R_4 X_3$ is possible.

Here, we propose an idea of crystal growth that is very effective in the case of poor information of the phase diagram. In this method the necessary informations are roughly estimated peritectic temperature T_1 and T_2 and the composition of $R_4 X_3$ and $R_5 X_3$. Then the allowed area in which the crystallization is always possible is the triangle in the phase diagram Fig.21. In the case of rare earth pnictides, the difference between T_1 and T_2 achieves to a few hundred degrees, and the allowed area is rather wide. Therefore we may select one point in the allowed area to obtain a single crystal.

In practice we describe the crystallization of $Yb_4 As_3$ to explain this method. The starting material is pre-reacted powder of $Yb_3 As_2$ which may be made from several compositions. The powder is sealed in a W crucible, then the crucible is kept in the furnace under a temperature gradient near $1650^\circ C$ for about 10 days. The point determined by the composition ($Yb_3 As_2$) and the temperature ($1650^\circ C$) seems to locate in the

triangle mentioned above. In this method, another important point is this temperature gradient. Usually the temperature of the lower part of a crucible is lower about 10 degrees than that of the middle part.

If the crucible at that point is in the equilibrium state, there are liquid phase of Yb_aAs_b and solid phase of Yb_4As_3 in the ratio of l_1 to l_2 as shown in Fig.38. But the initial state of the crystallization is rather complicated because it is in the nonequilibrium state. We think that there are both solid phase consist of several compositions and liquid phase close to Yb_aAs_b . Because of the existence of the temperature gradient the solid phase of Yb_4As_3 gradually segregates from the liquid at the low temperature part of the crucible. Therefore the composition of the liquid phase deviates from Yb_aAs_b however by the supply from the other solid phase the composition of the liquid phase is conserved. Again the segregation of Yb_4As_3 takes place. By repeating this process again and again the content of the crucible achieves at quasiequilibrium. Finally we get a single crystal of Yb_4As_3 at low temperature part and liquid phase of the Yb_aAs_b at high temperature part in the ratio of l_2 to l_1 separately.

Unusual and much interesting properties are discovered in this compound. Temperature dependence of the resistivity of Yb_4As_3 is shown in Fig.39 as a typical illustration of its physical properties. The resistivity jumps abruptly at about 300K corresponding to the crystal structure deformation due to the charge ordering state of f-electron in the lower temperature side. At the higher temperature it is a valence fluctuation state analogous to Sm_3S_4 or Eu_3S_4 (19,20). The temperature dependence of the resistivity in this temperature region is strictly linear up to 600K which is very similar to that of high T_c superconductor of 123 yttrium compound (21). In this case, the extrapolation of the resistivity at 0K cross the zero.

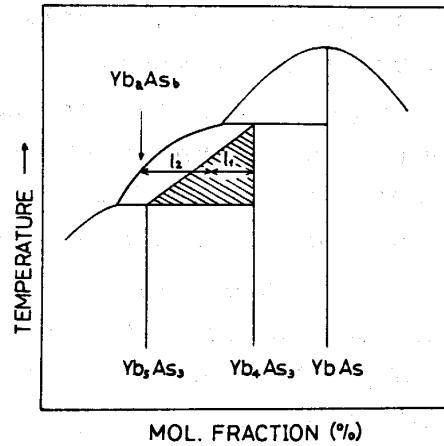

Fig.38 Conceptual phase diagram of the incongruent compound Yb_yAs_x .

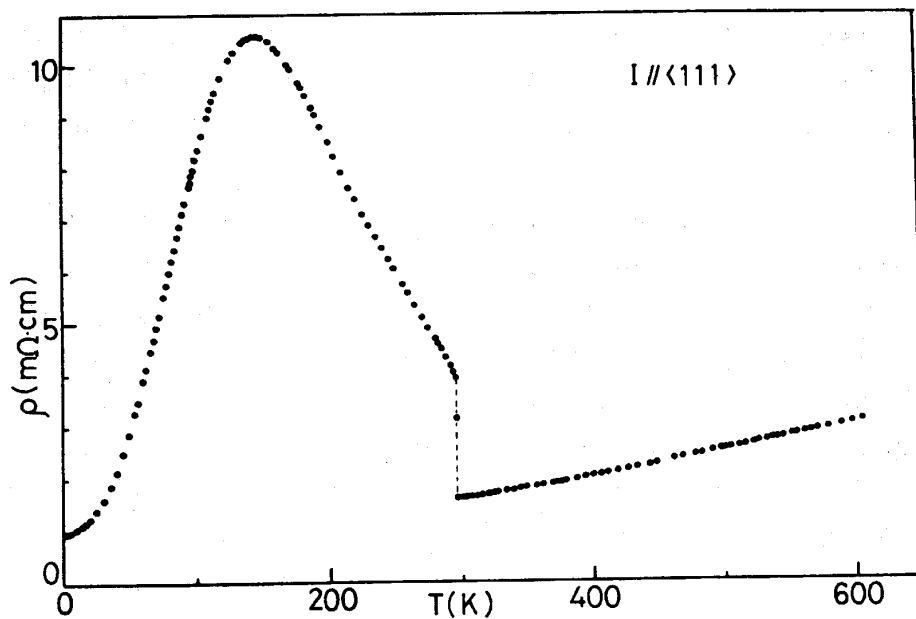

Fig.39 Temperature dependence of the resistivity of Yb_4As_3 single crystal.

resistivity. Furthermore, the similarity of Yb_4As_3 to the high T_c superconductor is its absolute value of the resistivity is almost same, and which suggest they have few carrier concentration. This fact is confirmed by the measurement of Hall effect and optical reflectivity that is 0.1% at 4.2K and few % above 300K of free carriers per formula unit respectively (22,23). Optical reflectivity of Yb_4As_3 is shown in Fig.40. Clearly the low plasma edge

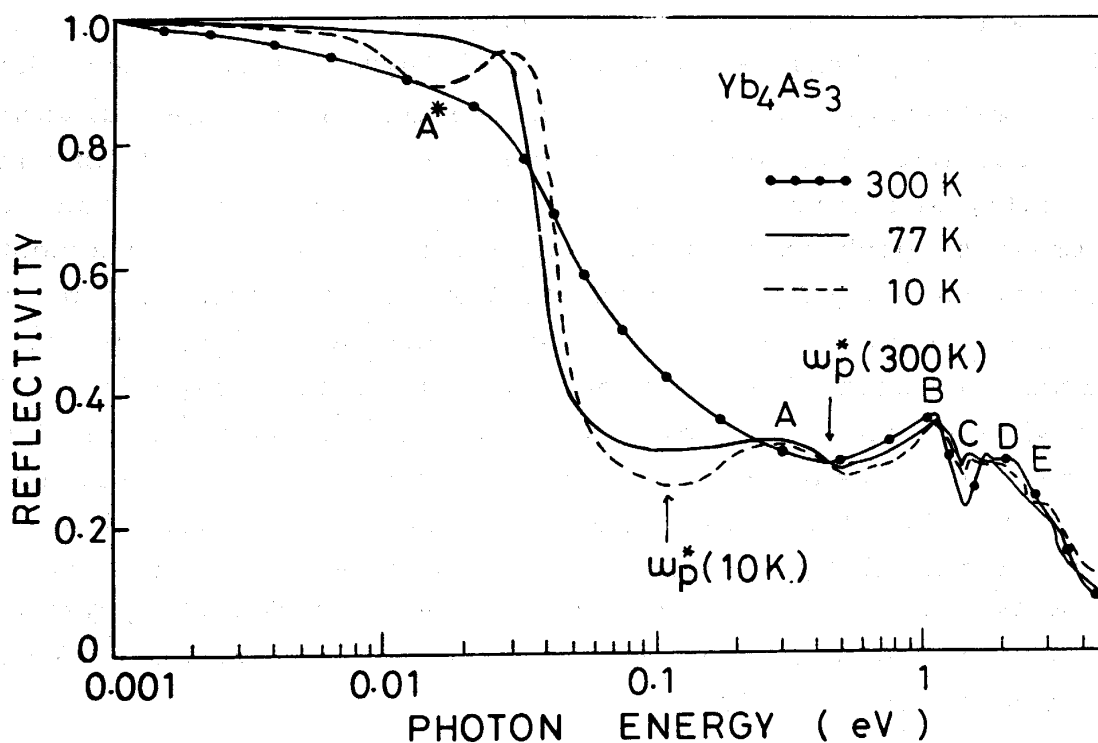

Fig.40 Optical reflectivity of Yb_4As_3 single crystal.

indicates low carrier concentration

$$\omega_p = \sqrt{\frac{N}{m^*}}$$

The similarity of Yb_4As_3 to the high T_c superconductor is not only carrier concentration but also the sign of the existence of hole conduction in valence band. The mechanism of high T_c superconductor is the most hot problem now. There should be some similarities of the conduction mechanism and of the strong correlated electron system in both materials. Strong correlation of this material is indicated more remarkably in the low temperature behaviors. The coefficient of linear term of the specific heat versus temperature which is proportional to the density of state of electron is evaluated as 200mJ/mol.deg^2 and the ratio between magnetic susceptibility at 0K and this electronic term of specific heat (so-called Wilson ratio) satisfies the Fermi liquid relations. Furthermore, the temperature dependence of the resistivity

obeys T^2 law pretty well from 2K to 100K. So it can be concluded that Yb_4As_3 is obviously heavy Fermion system. Anyway, such a heavy Fermion system with extremely low carrier concentration has not been discovered. Even in usual mettalic systems, there are few investigation that is systematically and currently carried out. Simple extension of the single impurity problem in Kondo state can not absolutely accept the existence of the heavy Fermion state in low carrier concentration system because such a simple imagination does to demand complete cancellation of the localized spin of f-electron and spin of the conduction electron making a singlet ground state at absolute zero temperature. Because the low carrier concentration system have not enough carriers to make singlet state with localized spin sited in each atomic site. The discovery of the heavy Fermion state in low carrier concentration of Yb_4As_3 really have extended the scope of the heavy Fermion physics, and it was one of the most attractive topics in the International Conference of Magnetism at Paris in 1988⁽²⁴⁾.

8.3 Chemical vapor growth method of U_3X_4

Vapour growth methods frequently guarantee to obtain very good quality of crystals but the obtained crystal size is usually small. This method is applicable to many materials regardless of congruent or incongruent if their vapour pressure is proper enough to crystal growth. Therefore it is available not only for pnictides and chalchogenides but also for compounds of Zn, Cd, Hg, etc. There are many methods in vapour growth. 1:1 compounds of pnictides and chalchogenides can be obtained by proper transport agent. For example when Eu_3S_4 in the evacuated and sealed molybdenum crucible is heated at 2000°C, the single crystal of EuS is grown in the crucible by vapour transport. This transport process is rather complex. First Eu_3S_4 decomposes to EuS at high temperature and excess sulphur reacts with molybdenum and produces MoS_2 . The transport of EuS from the hot zone to the cold zone occurs, and simultaneously the transport of Mo from the cold zone to the hot zone occurs. Same results is obtained when MoS_{2+e} (in Eu:S = 3:4 ratio) are used as the starting materials. It was discovered another transport that WP similarly act as transport agent for the crystal growth of rare-earth phosphide. Usual iodine transport method in a quartz ampoule was unsuccessful for the crystal growth of 1:1 compounds of pnictides and chalchogenides, because the growth rate is too low. For example, in

the case of NdAs, the needle crystals up to 5mm were obtained by the iodine transport method in which NdAs₂ + I in the ratio 1:1 was heated at 670°C and transported to one end of the quartz ampoule kept at 800°C. For 3:4 compounds, I₂ transport method in a quartz tube is very useful. We shall describe these procedure in detail.

On the assumption that there is a statistical distribution of imperfections and impurities on a quartz wall, the area of the nucleation point should be kept as small as possible. The most convenient method to achieve this condition is to form one end of a quartz ampoule into sharp conical shape. Then special treatment is necessary to decrease the number of active site on the quartz wall as follow;

- 1) The quartz tubes are vigorously washed with de-ionized water, scrubbed with clean brush and washed with acetone.
- 2) They are then put in pure HNO₃ overnight.
- 3) Etched for 15 minutes with mixture of HF-HNO₃ (1:1).
- 4) Washed with deionized water.
- 5) During glass blowing and after shaping, a systematic cleaning by flame from one end of the ampoule to the other is made by hand.
- 6) The ampoules are then washed with deionized water dried, evacuated to 10⁻⁶ torr.
- 7) Heated overnight at 1050°C to remove traces of HF and H₂O.
- 8) Then they are sealed off and opened only just before charging. The flame cleaning is of great importance because it closes any micro-holes or striations on the surface of a quartz tube.

8-4 Bridgman Method of Intermetallic Compound in Closed System.

All rare earth elements are not always non-volatile. Especially Yb and Eu metal are very volatile and easily attack on quartz ampoules. This is the largest reason that almost intermetallic compounds of Yb or Eu element are still remained in unexplored. Until we developed new crystal growth method of these compounds, preparation of these samples had been carried out by arc melting in open system in which it is difficult to avoid evaporation and escaping of constituents. In this case one must add excess Yb or Eu element before melting. The amount of excess element is determined by trial and error and repeated until X-ray diffraction shows single phase. However, disappearance of the other phases by X-ray diffraction can not always guarantee the stoichiometry

of these compounds. In fact the residual resistivity of these crystals obtained by arc melting are usually high up to several ten micro ohm cm. So it is desirable to synthesize even intermetallic compounds in closed system. Furthermore Yb and Eu element should be regard as volatile materials as well as pnictogen or chalcogen element.

Even in intermetallic compounds of non-volatile light rare earth metals such as La, Ce, Pr, Nd, Sm, the closed system is very effective to obtain good quality of these single crystals. There are many RX_3 compounds of CuAu₃ type crystal structure (R=Rare earth, X=Sn Pb Al Ga In Zn Cd Ni Pd Pt). The single crystals of almost these compounds can be rather easily prepared by Bridgman method in closed system because of its congruent nature. It is not necessary to pre-react the constituent elements before vacuum sealing in a crucible, because these elements does not escape in practically during sealing by electron beam. Zn and Cd are exceptional case, we have to make pre-reaction for the sake of its volatility. Whether the obtained single crystal has good quality is confirmed typically by the detection of evident dHVA signal. We could observe this signal in LaIn₃, PrIn₃, CeSn₃, LaSn₃ as shown in Fig.41 and Fig.42 for PrIn₃ and CeSn₃ respectively. The Fermi surfaces of these compounds have relative light so if we can obtain a good crystal with residual resistivity below $1\mu\Omega\text{cm}$, the dHVA signal can be measured under the usual condition ($T=1.2\text{K}$, Maximum magnetic field $H_{\text{max}}:10\text{T}$). We could get a good single crystal of CeIn₃ with residual resistivity of $0.6\mu\Omega\text{cm}$, but we cannot detect the dHVA signal under the same condition.

It should be necessary to use more extended condition ($T=20\text{mK}$ $H_{\text{max}}=15\text{T}$) for CeIn₃ with the heavy mass of the Fermi surface by the strong Kondo interaction. CeSn₃ is the typical substance with metallic valence fluctuation or Kondo substance with large T_K . In this case, usual band calculation can nicely reproduce Fermi surfaces obtained by experimental one, however the calculated effective mass of Fermi surfaces are much lower than experimental one. The origin of this mass enhancement is still remained unexplainable.

The interesting point of dHVA effect in PrIn₃ is the variation of some branch of the Fermi surfaces by the magnetic field. There are interaction(c-f) between localize moment and conduction electron. We can easily consider in singlet ground state that the Fermi surface changes with magnetic field, because magnetic moment is strongly increased as increasing external magnetic field. The results of PrIn₃ may be originated from this situation.

The analysis of this results are not so easy. Because the variation of the frequency by magnetic field can not correspond to the variation of the Fermi surface. Oscillation of dHvA is given by $\sin(\alpha F/H)$ (Here H :external field F :area of Fermi surface). If F changes linearly proportional to the magnetic field, there is no variation of the frequency by the magnetic field and we can only observe the Fermi surface at zero magnetic field.

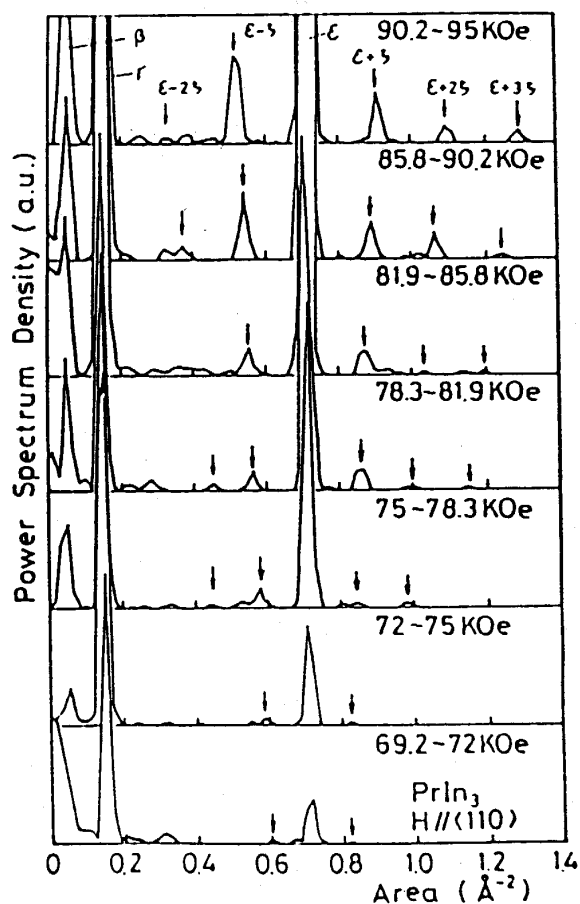

Fig.41 Observation of dHvA effect on the single crystal of PrIn_3

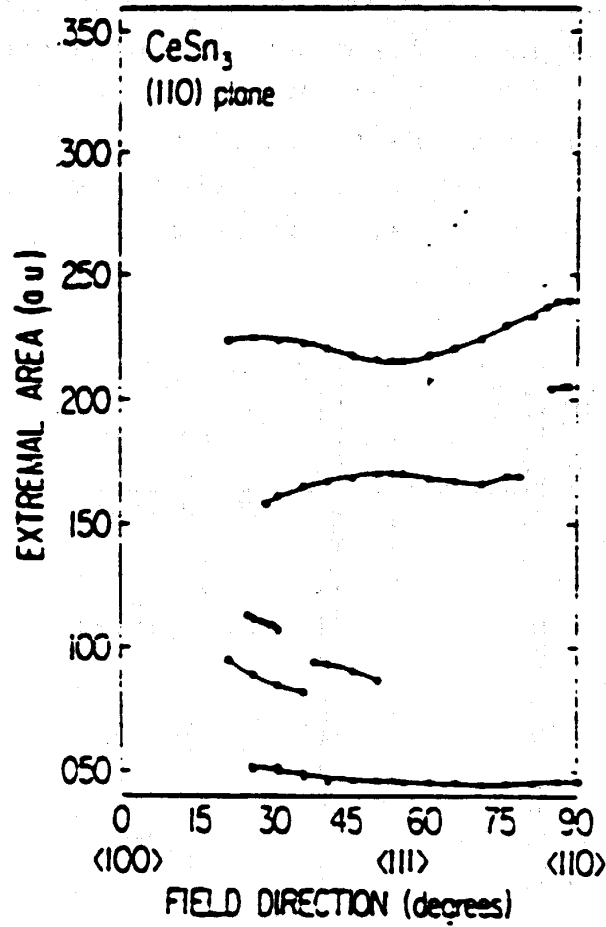

Fig.42 Observation of dHvA effect on the single crystal of CeSn_3

Accurate phase measurement can give the coefficient of variation of Fermi surface by magnetic field. The result of PrIn_3 suggests that some small pockets of Fermi surface are proportional to H^2 which cannot be expected from the simple parabolic band interacted with localized moments increased nearly linear by magnetic field.

More detailed studies are necessary. In the case of volatile Yb compounds it should be carefully made pre-reaction in a closed quartz or a Mo crucible. Yb element easily vaporized and condense at the cold end and attack the cold end of the crucible. If we apply the close system, it is rather easy to prepare single crystals without pre-reaction in the

very difficult to prevent the loss of heat by radiation from the heated crucible. However, our improvement of the radiation shield (PBN) have made our sample preparation possible. Now we can handle rather high temperatures over 2000 °C. Another desirable improvement on the moving system of the W crucible in the electron beam welding apparatus is to exchange manual moving into motor driving and now it is in progress too. Focusing of the electron beam are good enough for welding W crucible now but not enough to weld very thin and small sample container, because some instant welding method is necessary to it. It shall be improved in near future. Anyway, the total system for the crystal growth of the rare earth compounds constructed by us could really do work and enable us to get much fruitful results.

Acknowledgment

The authors would like to express their sincere thanks to financial of the Grant in aid for Scientific Research (special promoting research), The Ministry of Education, Science and Culture, from 1984 to 1986 and for continuous interest and encouragement.

Reference

- (1) W.C.Koehler; *J.Appl.Phys.* 36(1986) p.1070.
- (2) T.Kasuya, K.Takegahara, Y.Aoki, T.Suzuki, S.Kunii, M.Sera, N.Sato, T.Fujita, T.Goto, A.Tamaki and T.Komatsubara; in *Valence Instabilities*, eds. P.Wachter and H.Boppert, (North-Holland. Amsterdam 1982) p.359.
- (3) G.R.Stewart; *Rev.Mod.Phys.* 56(1984) p.455.
- (4) T.Kasuya; in *Theory of Heavy Fermions and Valence Fluctuations* eds. T.Kasuya and T.Saso (Springer-Verlag, Berlin, 1985) p.2.
- (5) E.Kaldis; *Crystal Growth, Theory and Techniques* C.H.I. Goodman Ed. Plenum Press(1984) p.96.
- (6) E.D.Eastman, L.Brewer, L.A.Bromley, P.W.Gilles and N.L.Lotgren; *J.American Ceramic Soc.* 34(1951) p.128.
- (7) E.Kaldis; *Crystal Growth, Theory and Techniques* C.H.I. Goodman Ed. Plenum Press(1974) p.98.
- (8) A.Oyamada et al to be published.
- (9) J.C.Spirlet and O.Vogt; *Hand book on the Physics and Chemistry of the Actinides* eds A.J.Freeman and G.H.Lander; Elsevier Science Publisher B.V.(1984).
- (10) E.Kaldis; *J. Crystal Growth* 24/25(1984) 53.
- (11) T.Suzuki, H.Kitazawa, M.Sera, I.Oguro, H.Shida, A.Yanase and T.Kasuya; in *Crystalline Electric Fields and f-Electron magnetism*, eds R.P.Guertin, W.Suzuki and Z.Zolnierek (Plenum, New York, 1982) p.357.
- (12) T.Kasuya, O.Sakai, J.Tanaka, H.Kitazawa and T.Suzuki *J.Magn.Magn.Mat.* 63&64(1987) p.9.
- (13) H.Aoki, G.W.Crabtree, W.Joss and F.Hulliger; *J.Magn.Magn.Mat* 52(1985) p.389.
- (14) O.Sakai, M.Takehige, H.Harima, K.Otaki and T.Kasuya *J.Magn.Magn.Mat.* 52(1985) p.12.
- (15) M.R.Norman and D.D.Keolling; *Phys.Rev.* B33(1986) p.6730.
- (16) H.Kitazawa, S.Sakatsume, T.Suzuki and T.Kasuya; *Proceedings of International Conference of Crystal Field and Heavy Fermion Physics at Frankfurt(1988)* to be published.
- (17) N. Takeda, private communications
- (18) A.Oyamada, P. Burllet, L.P.Regnault, A.Bouvet, R.Calemczuk, J.Rossat-Mignod, T.Suzuki and T.Kasuya

congruent Eu and Yb intermetallic compounds. Only one problem is left for the reactivity between the sample and the crucible. The reactivity of the general refractory compounds such as boride and carbide with W and Mo increases as temperature increases, therefore W or Mo crucibles cannot be used for the crystal growth of these compound above 2000°C.

Around 1500°C, most intermetallic compounds can be obtained in W or Mo crucibles. However strictly speaking the reactivity depends on the materials. So it is very promised method to introduce another crucible into sealed Mo or W crucible avoiding the direct touch between the metal crucible and the sample. Many refractory ceramics are available for such a crucible. Many incongruent intermetallic compounds have rather low peritectic temperature, so a quartz tube is applicable for the crucible. In this case vaporized Eu and Yb element condense at the cold end of the tube and easily attack the quartz tube. In such a case the following method is the best way; The quartz tube which encapsulates a proper container of the sample is hung in the vertical furnace where the temperature of the top is kept higher than that of the bottom. Then the temperature of the furnace is gradually increased. The single crystal of these compounds can be also obtained by segregation from off stoichiometric source as described in the case of Yb_4As_3 . We could succeed to prepare single crystals of several Yb intermetallic compounds of just stoichiometric. In the case of YbAl_3 , we could observe Kondo resonance peak at the fermi level for the first time.

9. Summary

Here we described and stressed the effectiveness of the crystal growth in closed system by introducing mainly W crucible encapsulation and several efforts for improvement of the total system of crystal growth in our method. After the completion of remarkable improvement of all procedure of the crystal growth and equipments especially the electron welding system with large glove box for multi-purpose and the vacuum furnace, several good single crystals were obtained as mentioned above, such as RX , R_4X_3 , U_3X_4 ($\text{R}=\text{Ce}, \text{Sm}, \text{Yb}$, $\text{X}=\text{P}, \text{As}, \text{Sb}, \text{Bi}$) and RY_3 ($\text{Y}=\text{Sn}, \text{In}$). We could get interesting information in these physical properties, respectively^(25,26,27). Since phosphide and nitride of 1:1 rare earth compounds have extremely high melting temperature, our vacuum furnace cannot be operated in such a high temperature mainly because that it is

- (19) O.Berkooz, M.Malamud and S.Shtrikmann; Solid State Commn. 6(1988) p.1851.
- (20) A.Ochiai, T.Suzuki and T.Kasuya; J.Magn.Magn.Mat. 52(1985) p.13.
- (21) See the following paper and the reference in it; H.Fukuyama and K.Yoshida; Jpn.J.Appl.Phys. 26(1987) L371.
- (22) Y.S.Kwon, A.Ochiai, H.Kitazawa, N.Sato, H.Abe, T.Namba, M.Ikezawa, K.Takegahara, T.Suzuki and T.Kasuya; Proceedings of the International Symposium on Magnetism of the Metallic of the Metallic Compound, Kyoto (1987).
- (23) A.Ochiai, T.Suzuki and T.Kasuya; to be published.