

# ENGINEERING JOURNAL

*Article*

## Study of Liquid Film Forming Apparatus (LFFA) Mechanisms in Terms of Oxygen Transfer and Bubble Hydrodynamic Parameters

Marupatch Jamnongwong<sup>1,a</sup>, Tawan Charoenpittaya<sup>2</sup>, Narapong Hongprasith<sup>2</sup>,  
Tsuyoshi Imai<sup>3</sup> and Pisut Painmanakul<sup>2,b,\*</sup>

<sup>1</sup> Department of Civil Engineering, King Mongkut's University of Technology North Bangkok, Bangkok, Thailand

<sup>2</sup> Department of Environmental Engineering, Faculty of Engineering, Chulalongkorn University, Bangkok, Thailand

<sup>3</sup> Division of Environmental Science and Engineering, Yamaguchi University, Yamaguchi, Japan  
E-mail: <sup>a</sup>marupatch.j@eng.kmutnb.ac.th, <sup>b</sup>pisut.p@chula.ac.th (Corresponding author)

**Abstract.** Aeration system is extensively applied in aquaculture and waste water treatment. It provides oxygen for organism living and mixing while consumes colossal amounts of energy for operating. Hence, the improvement of aeration system is not only providing enough oxygen and mixing but also concerning to the energy saving. Liquid film forming apparatus (LFFA) is a simple equipment that itself does not consume any power. It can be installed in existing conventional aeration system without large-scale retrofitting. Laboratory scale experiment was performed in a 190-litre aeration tank. The different types of air diffuser providing different bubble aspects were installed at the bottom of the aeration tank as the conventional diffused aeration systems. The volumetric mass transfer coefficient ( $k_L a$ ) of the aeration systems with LFFA are higher than the conventional systems notably. The mechanism of oxygen transfer in LFFA system can be summarized into 4 patterns: 1) Conventional mechanism, 2) Bubble collection mechanism, 3) Bubble recirculation mechanism and 4) Bubble-Liquid Foam mechanism. Then, the interfacial area ( $a$ ) is improved comparing with the conventional diffused aeration system. The LFFA system should be operated with small bubble diameter generation ( $< 3$  mm). The  $k_L a$  can be increased 11 – 37 % depending on generated bubble size. By determining the additional interfacial area ( $a_+$ ), the bubble collection phenomena, as well as, the proper superficial gas velocity ( $>0.13$  m/s) can be defined and provided a better understanding on oxygen transfer mechanism in LFFA system.

**Keywords:** Liquid film forming apparatus, diffused aeration system, volumetric mass transfer coefficient, interfacial area, oxygen transfer efficiency, superficial gas velocity, bubble hydrodynamic.

ENGINEERING JOURNAL Volume 20 Issue 3

Received 5 November 2015

Accepted 6 January 2016

Published 19 August 2016

Online at <http://www.engj.org/>

DOI:10.4186/ej.2016.20.3.77

## 1. Introduction

The aeration system that air is mixed with or dissolved in liquid in order to increase oxygen content of water is extensively applied in aquacultures for examples fish farming, shrimp farming, etc. for the organisms living as well as bioreactors, an urban waste water treatment for the microorganism metabolism. The oxygen will be transferred into the liquid phase as dissolved oxygen via interfacial film between gas phase and liquid phase. Hence, the oxygen transfer in aeration systems can be divided into two processes: bubble oxygen transfer and surface oxygen transfer. Then turbulence or mixing will be needed to distribute dissolved oxygen concentration uniformly in liquid phase [1]. Generally, the conventional aeration system introduces oxygen gas into liquid phase by either diffused or mechanical aerators in order to provide enough oxygen for organisms living and mixing. However, in case of real operating condition, more than half of the total power consumption in waste water treatment plants are related to their aeration system. Thus, the improvement of highly efficient aeration system has presently not only providing oxygen and mixing but also concerning to the energy saving.

The performance of the aeration system, as well as related the energy consumption is definitely linked to the efficiency of the oxygen transfer phenomena. Therefore, many researches have focused on the enhancement of the oxygen transfer efficiency by developing variety of new aeration techniques mostly concerning bubble oxygen transfer, including the high-purity-oxygen aeration, deep tank aeration, fine bubble aeration, etc. and also the characteristics of bubble rising from the diffuser to the water surface [2-25]. There was only a little effort devoted to the research on the improvement of surface oxygen transfer which indicated that is approximately one-third of the total volumetric mass transfer coefficient ( $k_L a_t$ ) [26-29]. Liquid-film aeration system (LFAS) which consists of liquid film forming apparatus (LFFA) is developed by aiming to enhance surface oxygen transfer. It has a very simple structure and can be installed on the water surface of existing conventional aeration system without large-scale retrofitting. Moreover, LFFA itself does not consume any power, it is also suitable for the energy saving. Imai and Zhu indicated that, at the air flow rate range 6 – 12 L/min, the aeration efficiency of LFFA system increases by 6.3 – 14.3% compare with conventional aeration system [30].

In order to understand the LFFA mechanism for improving the aeration efficiency, the oxygen transfer in LFFA aeration systems is divided into bubble oxygen transfer and surface oxygen transfer. Conventional diffused aeration system with and without LFFA are also compared to evaluate the oxygen transfer efficiency due to LFFA. Moreover, different types of air diffuser that provide different bubble aspects are examined in order to determine the hydrodynamic parameters that control the LFFA efficiency. Then, the mechanisms that improve the aeration efficiency can be clearly exposed. Finally, the proper operating condition and the preliminary design criteria can be proposed to be the guideline for improvement efficiency of aeration systems by LFFA.

## 2. Materials and Methods

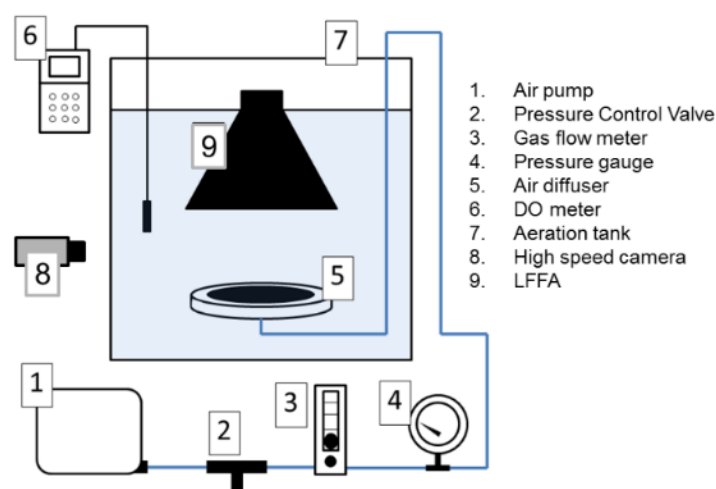

Fig. 2.1. The experimental setup.

## 2.1. Experimental Setup

The experimental setup schematic is presented in Fig. 2.1. An air diffuser (5) was installed in a 190 L capacity cubic tank (7) with a surface area of 3,600 cm<sup>2</sup>. Its location was at the center of the experimental water tank bottom with an aeration depth of 52 cm. Bubble was generated by an air pump (1) passing air ( $Q_g$ ) regulated by gas flow meter (3) through the air diffuser. Three types of air diffuser: (A) rigid diffuser, (B) membrane diffuser and (C) tubular diffuser as shown in Fig. 2.2 were used in this study. Both pressure control valve (2) and pressure gauge (4) were used for measuring the pressure drop across the air diffuser. The liquid-film apparatus (LFFA) (9) was installed at the surface water over the air diffuser. The schematic drawing of the LFFA is shown in Fig. 2.3. The LFFA, made of plastic here, consists of 2 parts: (i) cone-shaped capture part as a bubbles collector and (ii) effluent part located at the top of the cone. Air bubbles released from the air diffuser were collected inside the capture part and released through the effluent part as a liquid foam. Then the aeration system with and without LFFA were study.

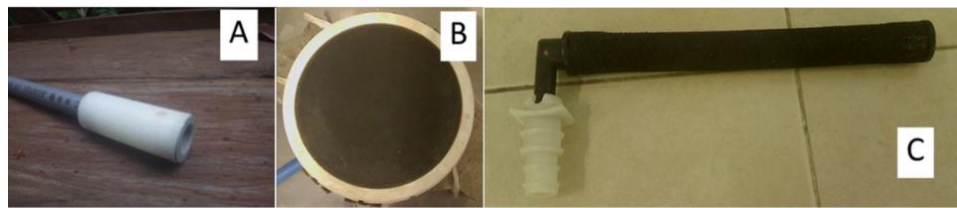

Fig. 2.2. Different types of air diffuser using in this study.

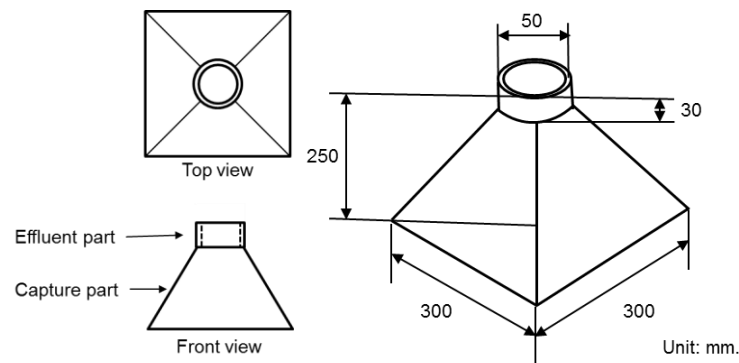

Fig. 2.3. Schematic drawing of the LFFA equipment.

## 2.2. Analytical Parameters

Bubble hydrodynamic parameters were investigated by using a high speed camera with 350 frames/sec (8) and image analysis software ImageJ and Image Frame work. The average bubble diameter ( $d_B$ ) and its rising velocity ( $U_B$ ) were deduced from the measurement of bubbles. Next, the average bubble formation frequency ( $f_B$ ) and the number of bubbles in the aeration system ( $N_B$ ) were determined by Eq. (2.1) and Eq. (2.2) respectively. Then, the specific area ( $a$ ) was determined by Eq. (2.3) as presented in Table 2.1, where  $Q_g$  represents the gas flow rate,  $V_B$  the volume of a bubble,  $A$  the cross-section area and  $H_L$  the height of liquid.

The oxygen transfer was measured by the standard method of ASCE (1993) [31]. The change of dissolved oxygen concentration was measured by DO meter (6), Horiba OM-51. Nitrogen gas was used for decreasing amount of dissolved oxygen in water as well as sodium sulfite ( $Na_2SO_3$ ) with Cobalt chloride ( $CoCl_2$ ) as its catalyze. All chemical solution was injected at the top of the tank. The calculation of total volumetric mass transfer coefficient ( $k_L a_T$ ) is given by Eq. (2.4), where  $C_s$  represents the saturated oxygen concentration,  $C_i$  the initial oxygen concentration,  $C_f$  the final oxygen concentration and  $t$  the duration time. Finally, all above calculated volumetric mass transfer coefficient was converted to standard condition temperature (20°C) by Eq. (2.5), where  $T$  represents the temperature. When the volumetric mass transfer coefficient and the specific area were determined, the liquid side mass transfer coefficient could be

calculated by Eq. (2.6) as presented in Table 2.1. Moreover, the aeration performance evaluation as standard oxygen transfer rate (SOTR), standard oxygen transfer efficiency (SOTE) and standard aeration efficiency (SAE) were calculated by Eq. (2.7)–(2.9). Where  $V$  represents the volume of reactor,  $G_s$  the total air flowrate and  $WP$  the power input.

Table 2.1 Analytical methods for determining the bubble hydrodynamic, mass transfer and aeration performance parameters.

Equation		
Bubble Hydrodynamic parameters	Mass transfer parameters	Aeration performance parameters
$f_B = \frac{Q_g}{V_B}$ (2.1)	$\frac{C_s - C_f}{C_s - C_i} = e^{-(k_L a_T)t}$ (2.4)	$SOTR = k_L a_{20} C_{s20} V$ (2.7)
$N_B = f_B \times \frac{H}{U_B}$ (2.2)	$k_L a_{(20)} = k_L a_{(T)} \times 1.024^{(20-T)}$ (2.5)	$SOTE = \frac{SOTR}{0.3G_s}$ (2.8)
$a = N_B \times \frac{\pi d_B^2}{AH_L + N_B V_B}$ (2.3)	$k_L = \frac{k_L a}{a}$ (2.6)	$SAE = \frac{SOTR}{WP}$ (2.9)

### 3. Results and Discussion

#### 3.1. Effect of Air Diffuser In Conventional Diffused Aeration System

In this research, the different gas diffusers: rigid diffuser (RD), tubular diffuser (ED) and membrane diffuser (MD) were selected in order to analyze the mass transfer and bubble hydrodynamic parameters. This experimental will be applied as the representative results from the conventional aeration system, as well as, compared with those from LFFA system. The variation of  $k_L a$  coefficient with the air flow rate was presented as in Fig. 3.1. It can be noted that the values of  $k_L a$  obtained with RD, ED and MD increase with air flow rate. Whatever the air flow rate, the  $k_L a$  coefficients from MD diffuser were greater than those from ED and RD diffusers.

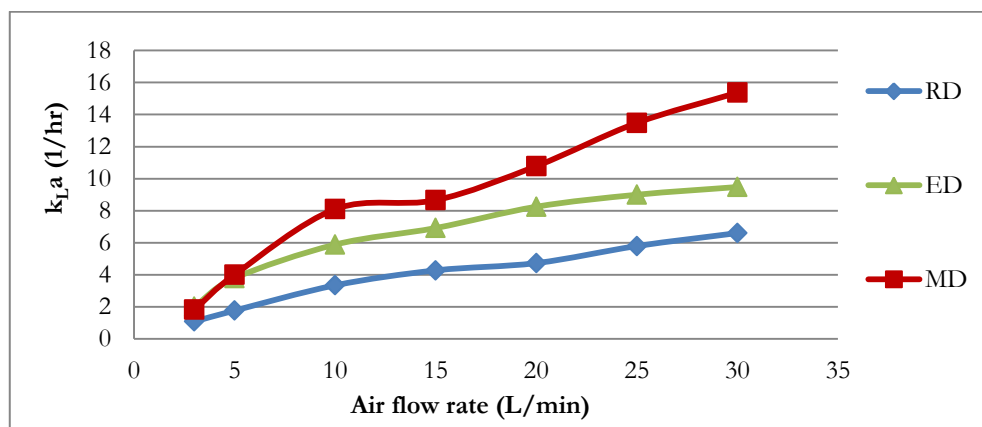

Fig. 3.1. Volumetric mass transfer coefficient ( $k_L a$ ) versus air flow rate for different air diffusers.

Moreover, the aeration performance parameters in terms of the related pressure drop for bubble generation ( $\Delta P$ ), standard oxygen transfer efficiency (SOTE) and standard aeration efficiency (SAE) were calculated and summarized as in Table 3.1.

Table 3.1 Effect of air flow rate on mass transfer and hydrodynamic parameters.

Aeration systems	Air flow rate (L/min)	Aeration performance parameters			Hydrodynamic parameters		
		SOTE (kg/cu.m)	Pressure drop (lb/sq.in)	SAE (kg/Cu.m -kW)	Bubble diameter (cm)	Bubble rising velocity (cm/s)	Interfacial area (1/m)
RD	3	0.035	0.70	3.07	0.290	33.24	0.70
	5	0.034	0.80	2.79	0.312	33.80	1.06
	10	0.032	0.93	2.42	0.341	37.66	1.74
	15	0.027	1.02	1.95	0.353	40.85	2.33
	20	0.023	1.08	1.56	0.382	47.75	2.45
	25	0.022	1.11	1.50	0.400	44.82	3.12
	30	0.021	1.23	1.34	0.391	43.59	3.93
ED	3	0.065	1.05	4.51	0.209	30.21	1.06
	5	0.073	1.10	4.95	0.235	27.80	1.72
	10	0.057	1.40	3.28	0.262	30.80	2.78
	15	0.044	1.65	2.30	0.295	31.30	3.64
	20	0.040	2.05	1.76	0.311	38.40	3.76
	25	0.035	2.45	1.34	0.324	40.58	4.25
	30	0.030	3.20	0.96	0.323	42.40	4.90
MD	3	0.059	1.03	4.15	0.133	30.11	1.68
	5	0.077	1.10	5.23	0.151	22.73	3.26
	10	0.078	1.13	5.19	0.163	25.66	5.36
	15	0.055	1.17	3.62	0.186	22.86	7.88
	20	0.052	1.26	3.22	0.220	32.47	6.28
	25	0.052	1.30	3.16	0.243	32.16	7.16
	30	0.049	1.40	2.85	0.265	38.72	6.55

As indicated in Table 3.1, MD and ED diffusers can provide the higher aeration performance than the RD one. Noted that these results correspond theoretically with the  $k_L a$  coefficient and power consumption for bubble generation (pressure drop). In order to provide a better understanding on the volumetric mass transfer coefficients and the related aeration performance parameters. Hydrodynamic aspects of bubble released from different types of air diffuser were captured by high speed camera and measured for bubble size and bubble rising velocity. These basic data will be used to analyze and explain other parameters concerning mass transfer phenomena. The overall results can be summarized as shown in Table 3.1, and discussed in detail as following:

- Bubble size from RD, ED and MD tend to increase with increasing air flow rate. In the air flow rate range of 3 – 30 L/min, MD produced the smallest bubble at 0.13 – 0.26 cm diameter. While ED produced bigger bubble at 0.21 – 0.32 cm diameter. And RD produced the biggest bubble at 0.29 – 0.40 cm diameter. Not only air flow rate but also material and pore size of air diffuser that control bubble size. MD and ED were made of expandable elastic rubber. Their pore size were larger when turn air flow rate higher. While RD was made of ridged material that release air bubble from fix pore size. Therefore, the range of bubble size obtained with MD and ED are wider than those obtained with RD;
- Series of the rising bubble images were used to analyze their rising velocity. It can be noted that bubble velocity from RD, ED and MD are tend to increase with increasing air flow rate. In the air flow rate range of 3 – 30 L/min, bubble velocity from RD is highest followed by ED and MD at 33-48, 28-42 and 23-39 cm/s as a sequence: the effect of bubble size should be responsible for these results.

- The experimental results of bubble diameter and rising velocity lead to the calculation of interfacial area ( $a$ ). The value of  $a$  tends to increase with increasing air flow rate. The interfacial area of ED displays an evolving trend same as that of RD. In the air flow rate range of 3 – 30 L/min, it moderate increases with increasing air flow rate. While that of MD shows steeper increase trend than that of the others. The interfacial area of MD, ED and RD are 1.68 – 7.88, 1.06 – 4.94 and 0.70 - 3.93 /m respectively. Noted that the interfacial area depends on surface area and retention time of bubble in liquid. Thus, the smallest bubble size from MD can maximize the bubble transferred-surface due to the highest number of bubbles, the retention time due to the slowest bubble rising velocity, as well as, the interfacial area.

Due to the  $k_L$  coefficient calculated by Eq. (2.6), the  $k_L$  values (obtained experimentally) vary between 0.0002 and 0.00045 m.s<sup>-1</sup> for bubble sizes varying between 0.15 and 0.5 cm. Moreover, it can be noted that the  $k_L$  value remain roughly constant for these range of bubble diameter. The results in this study agree with the three zones of the  $k_L$  coefficients proposed by [32]. In order to enhance the  $k_L a$  coefficient and overall aeration performance, the alternative method for improving the interfacial area, as well as, for controlling the power consumption should be well considered. The Liquid Film Forming Apparatus (LFFA) will be thus applied, as well as, analyzed in terms of aeration mechanism and related bubble hydrodynamic parameters in the next part.

### 3.2. Comparing the Aeration System with and without LFFA

In this part, the aeration systems with air diffuser (RD, ED and MD) and with LFFA (RDL, EDL and MDL) were compared in terms of mass transfer coefficient ( $k_L a$ ) and aeration performance. Fig. 3.2 presents firstly the example of dissolved oxygen (DO) versus operation time obtained with membrane diffuser (MD and MDL). It can be observed that the values of DO obtained with LFFA system were greater than those obtained with the conventional system: LFFA can possibly augment or modify the aeration performance with the similar power consumption for bubble generation. In order to confirm and understand the influence of LFFA installation, the effect of various diffusers with LFFA system on the volumetric mass transfer coefficient ( $k_L a$ ) and standard oxygen transfer efficiency (SOTE) will be then investigated as shown in Figs. 3.3 and 3.4, respectively.

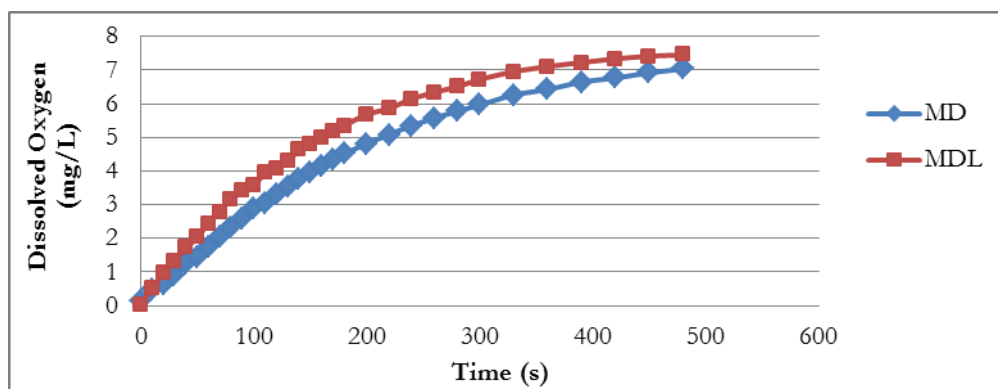

Fig. 3.2. Comparison of dissolved oxygen (DO) in function of aeration time from conventional and LFFA system at air flow rate of 30 L/min.

Concerning to Fig. 3.3, it can be indicated that, whatever the aeration systems, the volumetric mass transfer coefficient increases with the gas flow rate. The values of  $k_L a$  vary between 1.6 and 21 hr<sup>-1</sup> for gas flow rates varying between 3 and 30 L/min. Moreover, by using the LFFA system, the increase of  $k_L a$  coefficients can be concluded for whatever the diffuser types. The lowest  $k_L a$  coefficient is obtained for the RD system and the highest for MDL system. Noted that, overall the resulting trend was similar to that obtained with the conventional system as shown in Fig. 3.1. Therefore, the selection of diffuser with the small bubble size generation can be defined as one of the important factors for improving the aeration performance by LFFA system.

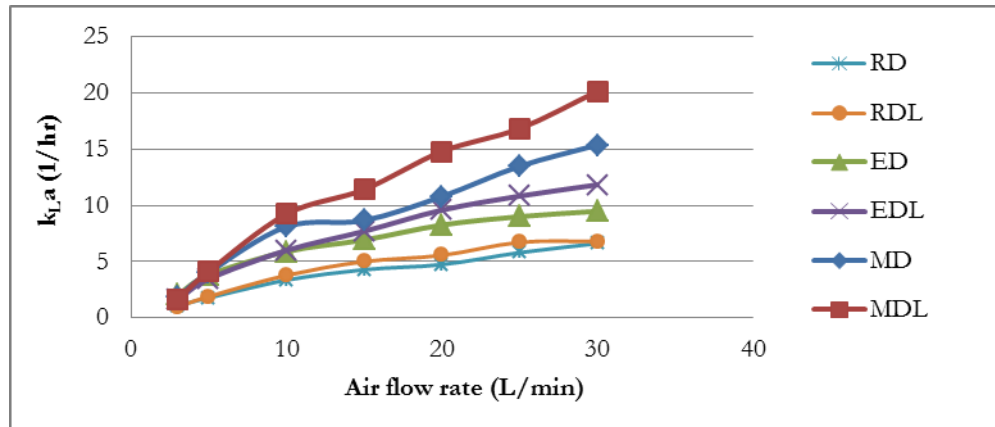

Fig. 3.3. Volumetric mass transfer coefficient ( $k_{L,a}$ ) versus air flow rate for conventional and LFFA system.

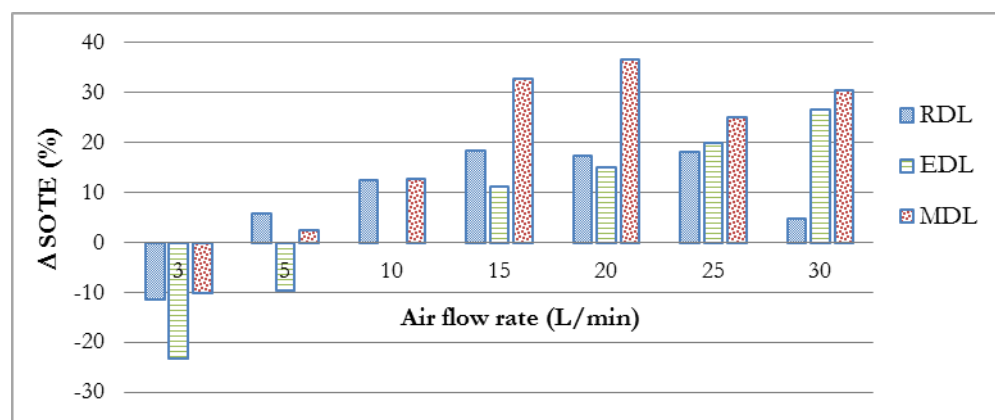

Fig. 3.4. Difference of standard oxygen transfer efficiency (SOTE) from conventional and LFFA system.

By determining the standard oxygen transfer efficiency (SOTE) as in Fig. 3.4, it can be noted that, at low air flow rate ( $< 3$  L/min), the values of SOTE obtained with LFFA system was lower than those obtained with conventional ones for whatever the diffuser types. The limitation of liquid phase mixing and of oxygen transfer due to the liquid surface turbulence should be responsible for these results [27]. When air flow rate increases, LFFA system can enhance the SOTE values- the highest SOTE improvement can be observed with MDL at air flow rate of 30 L/min. However, for higher air flow rate, it is interesting to note that the SOTE tend to be roughly constant for MDL and EDL system, whereas, to be significantly decreased for RDL system. The air flow rate ( $Q_G$ ) or superficial gas velocity ( $V_G$ ) should be taken into account for optimizing the aeration performance. Noted that bubble coalescence phenomena occurred at high  $Q_G$  values affecting directly on the interfacial area, as shown in Table 3.1, can be probably concluded as the reason for these negative results. Therefore, the oxygen transfer rate and the aeration efficiency can be successfully developed by LFFA within the suitable design and operating condition. Moreover, about the bubble hydrodynamic aspects, the LFFA system should be operated with small bubble diameter generation ( $< 3$  mm), as well as, with moderate air flow rate (5–30 L/min) in order to well improve the aeration performance.

In the next section, the LFFA system will be mathematically analyzed for distributing the oxygen transfer mechanism as: 1) mass transfer from bubble in reactor and 2) mass transfer at liquid surface. Note that rigid (RD) and membrane (MD) diffusers were selected in order to provide a better understanding and clearly difference on the obtained results.

### 3.3. Comparison of the Volumetric Mass Transfer Coefficient in Terms of Bubble and Surface Mass Transfer Mechanism from LFFA System

The dissociation method for studying the oxygen transferred by bubble in reactor and water surface turbulence proposed by Wilhelms and Martin (1992) has been applied in this work. By diffusing nitrogen gas into water instead of air, the liquid phase is deoxygenated: the only way that oxygen can transfer to water, in the same time, is due to the liquid surface turbulence. Then, the basic oxygen transfer equation is presented as Eq. (3.1).

$$\frac{dC}{dt} = \left[ \frac{\partial C}{\partial t} \right]_b + \left[ \frac{\partial C}{\partial t} \right]_s \quad (3.1)$$

where  $\frac{dC}{dt}$  = rate of mass transfer.

$$\left[ \frac{\partial C}{\partial t} \right]_b = (k_L a_b)(C_s - C) = \text{rate of mass transfer from bubble} \quad (3.2)$$

$$\left[ \frac{\partial C}{\partial t} \right]_s = (k_L a_s)(C_s - C) = \text{rate of mass transfer from surface} \quad (3.3)$$

The saturated oxygen concentration ( $C_s$ ) from bubble is equal to zero when the liquid phase is deoxygenated. Then, the rate of mass transfer from bubble is presented as Eq. (3.4).

$$\left[ \frac{\partial C}{\partial t} \right]_b = -[k_L a]_b C \quad (3.4)$$

Since the saturated oxygen concentration from surface is followed by Henry's Law. When Eq. (3.3) and Eq. (3.4) are substituted in Eq. (3.1), the integration between the initial concentration ( $C_i$ ) and the final concentration ( $C_f$ ) is presented as Eq. (3.5).

$$\frac{(k_L a_s)C_s - (k_L a_s + k_L a_b)C_f}{(k_L a_s)C_s - (k_L a_s + k_L a_b)C_i} = e^{-(k_L a_s + k_L a_b)t} \quad (3.5)$$

The values of oxygen concentration from experiments with nitrogen gas were recorded. Then, the values of  $k_L a_b$  and  $k_L a_s$  can be thus determined by nonlinear regression equation as Eq. (3.5). Figure 3.5 and 3.6 present the variation of  $k_L a$  coefficient from bubble ( $k_L a_b$ ) and surface ( $k_L a_s$ ) mass transfer phenomena with the different air flow rates for the rigid (RD) and membrane (MD) diffusers, respectively.

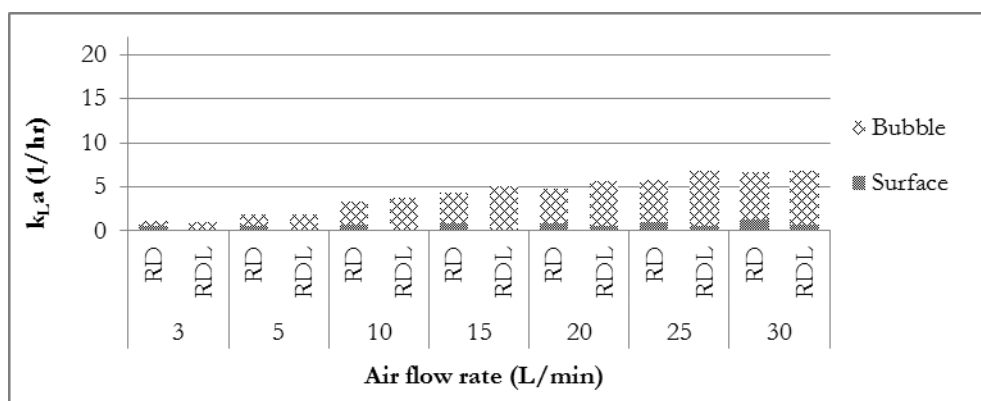

Fig. 3.5. Comparison of the volumetric mass transfer coefficient in terms of bubble and surface mass transfer mechanism from RD and RDL.



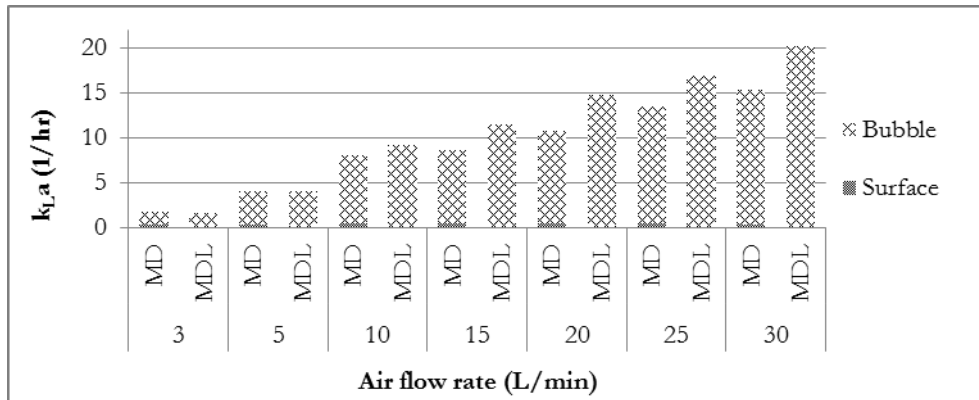

Fig. 3.6. Comparison of the volumetric mass transfer coefficient in terms of bubble and surface mass transfer mechanism from MD and MDL.

A comparison between  $k_L a_b$  and  $k_L a_s$  obtained with LFFA and conventional system can be summarized, as well as, the following comments can be made:

- whatever the aeration system, the  $k_L a$  coefficients from bubble in reactor ( $k_L a_b$ ) were higher than those from liquid surface turbulence ( $k_L a_s$ ). The average  $k_L a_s$  to  $k_L a_b$  ratio can be 0.15 and 0.05 for rigid and membrane diffusers, respectively. Form the experiments conducted by Wilhelms and Martin (1992), one-third of oxygen transfer in the bubble plume aeration tank was due to the surface exchange. The difference of bubble generation regimes that induces mixing and gas transfer should be answerable for these results.
- the overall  $k_L a$  coefficients tend to increase with increasing air flow rate, especially for  $k_L a_b$  values- this is due to the augmentation of bubble number and interfacial area. However, the irrelevant change of  $k_L a_s$  values should be related with the limitation of mixing or turbulent at liquid surface from the range of air flow rate used in this work.
- by installing the LFFA system, the reduction of  $k_L a_s$  to  $k_L a_b$  ratio can be observed. The bubble collection or accumulation within the cone-shaped capture part, as well as, can possibly diminish the oxygen transfer at liquid surface and thus the obtained  $k_L a_s$  coefficient.
- the  $k_L a_s$  coefficients in the case of rigid diffuser (RD and RDL) were larger than those in the case of membrane diffuser (MD and MDL). The more pronounce of large-size bubble plume and generated liquid-bubble foam at liquid surface should be the main reason for these results.

In order to validate the obtained results, another experiment was set up by the same aeration tank, and the same operational condition with the RDL. But the tank was covered at the top, then nitrogen gas was passed beyond the water surface by the same as air flow rate in each condition, according to diminishing the surface transfer and measuring the bubble transfer individually. The experimental set-up and related results can be presented in Figure 3.7a. and 3.7b., respectively.

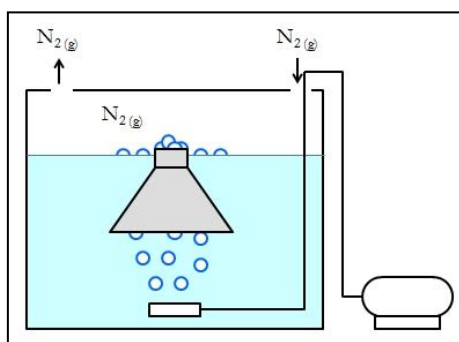

Fig. 3.7a. Experimental set-up for validating the bubble and surface transfer mechanism

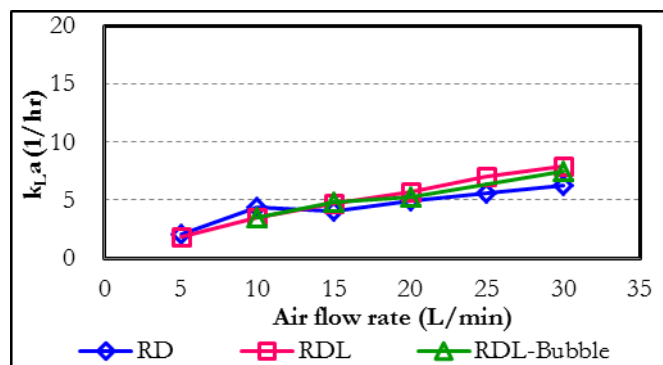

Fig. 3.7b.  $k_L a$  coefficient versus air flow rate for validating the bubble and surface mass transfer from RD and RDL

From the result, it was found that when the rigid diffuser was operated together with LFFA (RDL), the  $k_L a$  coefficient was improved by the same trend as the previous results. Comparing the  $k_L a$  obtained by the nitrogen condition which could be considered as the oxygen transfer on the water surface was inhibited, then the oxygen transfer was occurred by bubbles individually. When considered the  $k_L a$  of RDL as 100% of the system, the bubble transfer by the nitrogen condition was around 94%. According to the assumption, which describe the total oxygen transfer consist of surface and bubble transfer, as following relation,

$$\text{Oxygen transfer} = \text{Surface transfer} + \text{Bubble transfer} \quad (3.6)$$

$$k_L a_{\text{Total}} = k_L a_{\text{Surface}} + k_L a_{\text{Bubble}} \quad (3.7)$$

According to the previous equation, the surface transfer can be obtained which it was around 6% of the total oxygen transfer. This result represented the  $k_L a$  was clearly improved in term of bubble collection within the cone part of the LFFA; this can increase interfacial area and extend contacting time between the bubbles and the water through the collection phenomenon. Moreover, when compared the conventional system (RD) with the LFFA system (RDL) at air flow rate higher than 15 L/min, it was found that the overall  $k_L a$  was increased around 21%, which could be allocated by 13% for bubble transfer improvement and 8% for surface transfer improvement. Therefore, the LFFA can improve the oxygen transfer both mechanisms of bubble transfer and surface transfer, by bubble collection phenomenon and foaming on the water surface by highly turbulent, bubble collection was more effective mechanism than the foaming on the surface. The bubble collection phenomena will be thus analyzed in the next part.

### 3.4. Bubble Collection Phenomena in LFFA System

In order to confirm the effect of bubble collection or accumulation from LFFA system on the  $k_L a$  coefficients, the image analysis experiment was conducted in this work. Figure 3.8 presents the variation of bubble accumulation height and light density ratio with air flow rate (3 – 30 L/min) for the different types of diffusers. Note that many images of bubbles inside LFFA were captured by using the high speed camera: the obtained images will be analysed in terms of bubbles accumulation aspect and their light density. Due to the installation of cone shape of LFFA, the bubble collection phenomena should be different, as well as, can be experimentally determined.

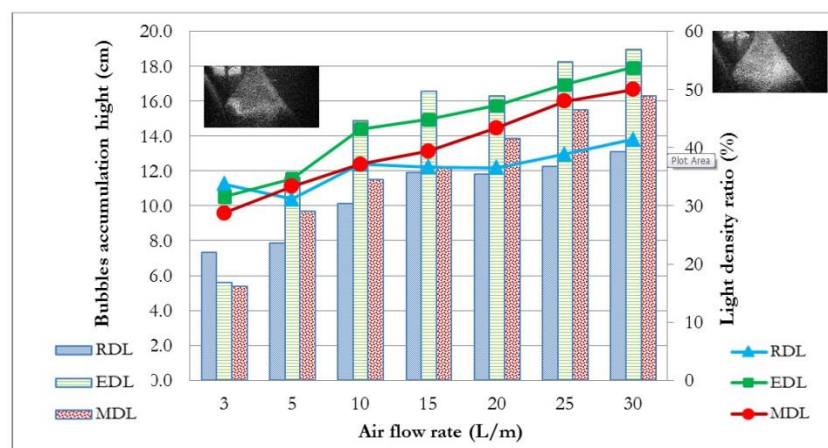

Fig. 3.8. Bubbles accumulation height and the light density ratio versus air flow rate for LFFA system.

As shown in Fig. 3.8, the bubble accumulation height increases with increasing air flow rate and then achieves the roughly constant values. The highest and lowest values were obtained with EDL and RDL, respectively. At low air flow rate (< 3 L/min), the height from RDL was greater than from EDL and MDL, whereas, the contradictory results were observed when the air flow rate increases. It can be expressed, at this point that the bubble accumulation height relates with the bubble size generated from the diffusers and with the air flow rate. Since the bubble density presence in LFFA cannot be directly determined by 2D

camera. Thus, Light density ratio measurement was also processed by software Image Frame Work as the representative parameter for observing the trend of bubbles density. Noted that the amount of light on image as ratio value comparing to the reference (white image) was measured. When the bubble density increases, light is more reflexed to the camera, as well as, the light density ratio increases. Comparing the light density ratio and bubble accumulation height, it can be noted that the similar trend can be observed. These 2 methods can be possibly applied in order to evaluate the bubble captured inside LFFA.

By considering the bubble hydrodynamic parameters as previously presented in Table 3.1, it can be noted that the differences in terms of bubble diameters are directly linked to bubble collection in LFFA: large bubble size can cause more bubble layer thickness and thus light density ratio. However, for higher air flow rate, the bubble coalescence can affect on the increase of bubble rising velocity, and thus the reduction of bubble collection in LFFA, especially in the case of RD. Concerning to the results obtained with EDL and MDL, it is interesting to understand the link between the mass transfer coefficient and the bubble collection in LFFA. Due to the small bubble generated from MD, these bubbles can be tightly packed inside the capture part, as well as, possibly recirculated within the reactor: the interfacial area is high compared to those obtained with the different diffusers. Moreover, the packed bed from small bubbles have more chance to discharge from the top of LFFA to liquid surface in order to gain the total oxygen transfer by surface oxygen transfer. Therefore, these results confirm to the high  $k_L a$  and oxygen transfer efficiency in the case of LFFA system with membrane diffuser (MDL) as previously shown.

In conclusion, from all the results above, the mechanism of oxygen transfer in LFFA system can be summarized into 4 patterns as shown in Fig. 3.9.

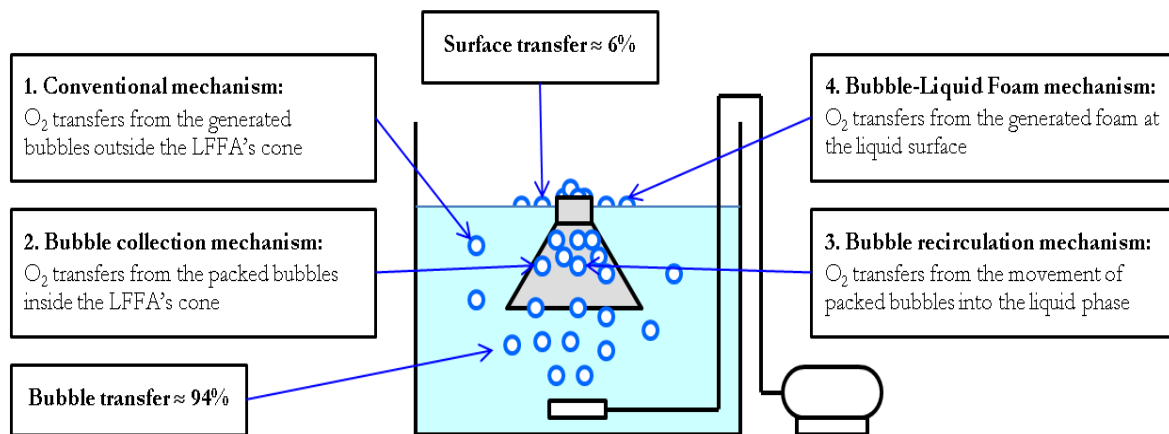

Fig. 3.9. Four patterns of oxygen transfer mechanisms in LFFA system.

### 3.5. Additional Interfacial Area in LFFA for Proposing the Design Criteria and Operating Condition

In order to propose the suitable LFFA design criteria and operating condition, the additional interfacial area ( $a_+$ ) in the aeration system with LFFA was defined and determined. Note that, from the experimental results, the average value of liquid-side mass transfer coefficient ( $k_{L\text{ Avg}} = 3 \cdot 10^{-4}$  m/s) related with the tap water was applied in this part. The additional interfacial area ( $a_+$ ) can be calculated by Eq. (3.8).

$$a_+ = \frac{k_L a_{TL} - k_L a_{TN}}{k_{L\text{ Avg}}} \quad (3.8)$$

where  $k_L a_{TL}$  and  $k_L a_{TN}$  represent the volumetric mass transfer coefficient obtained experimentally in aeration system with LFFA and in conventional aeration system, respectively. Figure 3.10 presents the variation of the additional interfacial area ( $a_+$ ) with air flow rate (3 – 30 L/min) for the different types of diffusers.

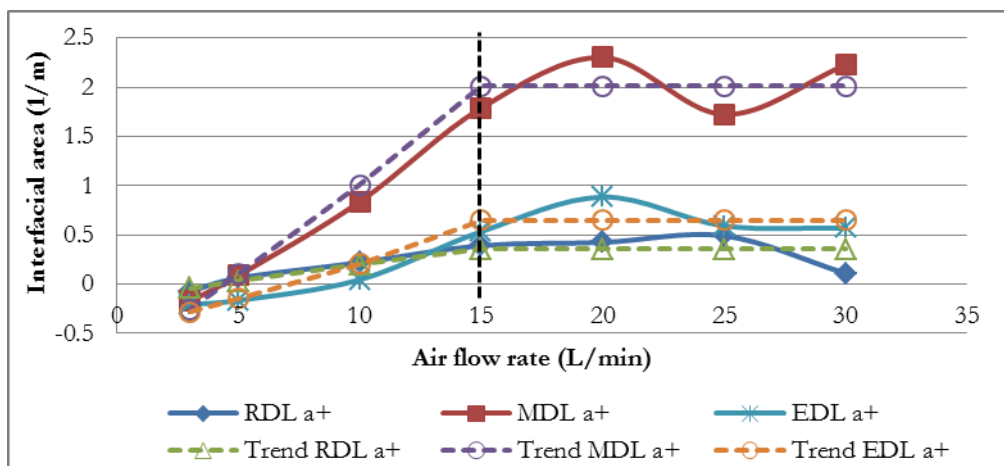

Fig. 3.10. Additional interfacial area versus air flow rate for LFFA system.

As shown in Fig. 3.10, three zones appear and are considered in the rest of this study for analyzing the variation of the  $a_+$  values with the air flow rate:

- Zone A for  $Q_G < 5$  L/min ( $V_G < 0.04$  m/s): The values of the additional interfacial area are very low or negative: the reduction of mixing and surface turbulent by LFFA should be responsible for these results.
- Zone B for  $5 < Q_G < 15$  L/min ( $0.04 < V_G < 0.13$  m/s): The  $a_+$  values increase for this air flow rate range, especially with MDL diffuser. Noted that the influent of bubble collection and recirculation within LFFA system plays the important role for these results. Moreover, the foam of liquid - bubble discharged from the top of LFFA can also enhance the surface oxygen transfer for whatever the diffusers.
- Zone C for  $Q_G > 15$  L/min ( $V_G > 0.13$  m/s): The  $a_+$  values do not depend on the air flow rate for whatever the applied diffusers. The decrease of interfacial area due to bubble coalescence phenomena and the increase of liquid - bubble foam at liquid surface compensate each other at higher air flow rate.

Table 3.2 Proposition of design criteria & operating condition for LFFA system.

	Description	Values
<b>Design configuration</b>	Area of effluent part of LFFA ( $\phi 50$ mm)	0.00196 m <sup>2</sup>
	Area of the cone of LFFA (300*300 mm)	0.09 m <sup>2</sup>
	Height of effluent part of LFFA	0.03 m
	Height of the cone of LFFA	0.25 m
<b>Design criteria</b>	Superficial gas velocity ( $V_G$ )	> 0.13 m/s
	Bubble size diameter	< 0.3 cm
	Diffuser / Cone area	0.35
	Covered Area per 1 LFFA	0.36 m <sup>2</sup>
<b>Performance (SOTE) at proposed <math>V_G</math></b>	RD / RDL	1.11
	ED / EDL	1.19
	MD / MDL	1.33

In conclusion, it can be stated that the selection of air diffuser and flow rate is very important for improving the aeration performance by using LFFA system. These can affect not only the conventional aeration mechanism by rising bubble in reactor, but also the bubble collection and foam of liquid - bubble obtained with LFFA system. From all results obtained in this research, the design criteria & operating condition is recommended and presented in Table 3.2.

#### 4. Conclusion

The LFFA can improve the oxygen transfer not only bubble oxygen transfer but also surface oxygen transfer. The mechanism of oxygen transfer in LFFA system can be summarized into 4 patterns: 1) Conventional mechanism, 2) Bubble collection mechanism, 3) Bubble recirculation mechanism and 4) Bubble-Liquid Foam mechanism. Without more power requirement, then, the interfacial area ( $a$ ) is improved comparing with the conventional diffused aeration system. The selection of diffuser with the small bubble size generation can be defined as one of the important factors for improving the aeration performance by LFFA system. The LFFA system should be operated with small bubble diameter generation ( $< 3$  mm). Then, the LFFA is able to increase  $k_L a$  25-37%, 11-25% and 13-17% for MDL, EDL and RDL respectively. For this LFFA aeration system, the proper superficial gas velocity is more than 0.13 m/s for 1 m<sup>2</sup> of the cross section area of its effluent part.

In future, it is evident that the results observed in the small aeration tank have to be validated in a large scale-system with different LFFA installation patterns. Finally, the theoretical models or correlations should be considered to compare the experimental results of bubble hydrodynamic and mass transfer parameters and predict the aeration efficiency obtained in a LFFA system.

#### Acknowledgements

This work has the financial support from the Higher Education Research Promotion and National Research University Project of Thailand, Office of the Higher Education Commission (Project Number FW1017A) and research funding of Faculty of Engineering, Chulalongkorn University. The authors would like to acknowledge the Graduate school of Chulalongkorn University, Center of Excellence for Environmental and Hazardous Waste Management (EHWM) of Chulalongkorn University for additional financial and technical support for materials supply. This research was partly supported by Steel Foundation for Environmental Protection Technology, Japan and Faculty of Engineering, King Mongkut's University of Technology North Bangkok (KMUTNB), Thailand.

#### References

- [1] S. Moustiri, "A unified correlation for predicting liquid axial dispersion coefficient in bubble columns," *Chem Eng Sci.*, vol. 56, no. 3, pp. 1041-1047, 2001.
- [2] J. Hadamard, "Mouvement permanent lent d'une sphere liquide et visqueuse dans un liquide visqueux," *Comptes Rendus de l'Académie des Sciences*, vol. 152, no. 25, pp. 1735-1738, 1911.
- [3] W. K. Lewis and W. C. Whitman, "Principles of gas adsorption," *Journal Industrial and Engineering Chemistry*, vol. 16, no. 12, pp. 1215-1220, 1924.
- [4] I. Leibson, E. G. Holcomb, A. G. Cacosso, and J. J. Jacmic, "Rate of flow and mechanics of bubble formation from single submerged orifices. I. Rate of flow studies," *AICHE Journal*, vol. 2, no. 3, pp. 296-300, 1956.
- [5] H. D. Mendelson, "The prediction of bubble terminal velocities from wave theory," *AICHE Journal*, vol. 13, no. 2, pp. 250-253, 1967.
- [6] K. Akita and F. Yoshida, "Gas holdup and volumetric mass transfer coefficient in bubble columns. Effects of liquid properties," *Industrial & Engineering Chemistry Process Design and Development*, vol. 12, no.1, pp. 76-80, 1973.
- [7] W. D. Deckwer, R. Burckhart, and G. Zoll, "Mixing and mass transfer in tall bubble columns," *Chemical Engineering Science*, vol. 29, no.11, pp. 2177-2188, 1974.
- [8] W. Gestrich and W. Krauss, "Die spezifische Phasengrenzfläche in Blasensäulen (The specific interfacial area in bubble columns)," *Chemie Ingenieur Technik*, vol. 47, no. 9, pp. 360-367, 1975.
- [9] A. Kumar, T. E. Degaleesan, G. S. Laddha, and H. E. Hoelscher, "Bubble swarm characteristics in bubble columns," *The Canadian Journal of Chemical Engineering*, vol. 54, no. 6, pp. 503-508, 1976.
- [10] J. R. Grace, T. Wairegi and T. H. Nguyen, "Shapes and velocities of single drops and bubbles moving freely through immiscible liquids," *Transactions of the Institution of Chemical Engineering*, vol. 54, no. 3, pp. 167-173, 1976.

- [11] T. Tomida, F. Yusa, and T. Okazaki, "Effective interfacial area and liquid-side mass transfer coefficient in the upward two-phase flow of gas-liquid mixtures," *The Chemical Engineering Journal*, vol. 16, no. 2, pp. 81-88, 1978.
- [12] B. M. Khudenko and E. Shpirt, "Hydrodynamic parameters of diffused air systems," *Water Research*, vol. 20, no. 7, pp. 905-915, 1986.
- [13] J. R. Grace and T. Wairegi, "Properties and characteristics of drops and bubbles," in *Encyclopedia of Fluid Mechanics*, P. N. Cheremisinoff, Ed. Huston: Gulf Publishing, 1986.
- [14] I. K. Ashley, S. D. Mavinic, and J. K. Hall, "Bench-scale study of oxygen transfer in coarse bubble diffused aeration," *Water Research*, vol. 26, no. 10, pp. 1289-1295, 1992.
- [15] W. D. Deckwer, *Bubble Column Reactors*. Wiley, 1992.
- [16] P. M. Wilkinson, H. Haringa, and L. L. Van Dierendonck, "Mass transfer and bubble size in a bubble column under pressure," *Chemical Engineering Science*, vol. 49, no. 9, pp. 1417-1427, 1994.
- [17] G. R. M. Hébrard, "Etude de l'influence du distributeur de gaz sur l'hydrodynamique et le transfert de matière gaz-liquide des colonnes à bulles," Thèse N°95, INSA Toulouse, 1995.
- [18] S. Moustiri, "Hydrodynamique des colonnes à bulles fonctionnant à co-courant de gaz et de liquide: Effet hydrodynamique produit par la présence d'un garnissage spécifique," Thèse N°601, INSA Toulouse, 2000.
- [19] J. Mueller, W. C. Boyle, and I. H. J. Popel, *Aeration: Principles and Practice*. Taylor & Francis, 2002.
- [20] M. Roustan, "Transferts gaz-liquide dans les procédés de traitement des eaux et des effluents gazeux," Paris, Tec & Doc, 2003.
- [21] P. Painmanakul, K. Loubiere, G. Hébrard, and P. Buffiere, "Study of different membrane spargers used in waste water treatment: characterisation and performance," *Chemical Engineering and Processing: Process Intensification*, vol. 43, no. 11, pp. 1347-1359, 2004.
- [22] R. Sardeing, P. Painmanakul, and G. Hébrard "Effect of surfactants on liquid-side mass transfer coefficients in gas-liquid systems: A first step to modeling," *Chemical Engineering Science*, vol. 61, no. 19, pp. 6249-6260, 2006.
- [23] P. Painmanakul and M. Jamnongwong, "Theoretical prediction of mass transfer parameters in small bubble column," in *Proceedings of Asian-Pacific Regional Conference on Practical Environmental Technologies (APRC 2007 International Conference)*, 2007.
- [24] A. Kumar, S. Moulick, and B. C. Mal, "Performance evaluation of propeller-aspirator-pump aerator," *Aquacultural Engineering*, vol. 42, no. 2, pp. 70-74, 2010.
- [25] M. Jamnongwong, K. Loubiere, N. Dietrich, and G. Hébrard, "Experimental study of oxygen diffusion coefficients in clean water containing salt, glucose or surfactant: Consequences on the liquid-side mass transfer coefficients," *Chemical Engineering Journal*, vol. 165, no.3, pp. 758-768, 2010.
- [26] J. R. McWhirter and J. C. Hutter, "Improved oxygen mass transfer modeling for diffused/subsurface aeration systems," *AIChE Journal*, vol. 35, no. 9, pp. 1527-1534, 1989.
- [27] S. C. Wilhelms and S. K. Martin, "Gas transfer in diffused bubble plumes," in *Hydraulic Engineering: Saving A Threatened Resource—In Search Of Solutions*, S. M. Jennings and N. G. Bhowmilk, Eds. New York: ASCE, 1992, pp. 317-322.
- [28] C. D. DeMoyer, E. L. Schierholz, J. S. Gulliver, and S. C. Wilhelms, "Impact of bubble and free surface oxygen transfer on diffused aeration systems," *Water Research*, vol. 37, no. 8, pp. 1890-1904, 2003.
- [29] H. Zhu, T. Imai, K. Tani, M. Ukita, M. Sekine, T. Higuchi, and Z. J. Zhang, "Enhancement of oxygen transfer efficiency in diffused aeration system using liquid-film-forming apparatus," *Environmental Technology*, vol. 28, no. 5, pp. 511-519, 2007.
- [30] T. Imai and H. Zhu, "Improvement of oxygen transfer efficiency in diffused aeration systems using liquid-film-forming apparatus," in *Mass Transfer—Advanced Aspects*, H. Nakajima, Ed. INTECH, 2011, pp. 341-370.
- [31] ASCE, *Measurement of Oxygen Transfer in Clean Water*. American Society of Civil Engineers, 1993.
- [32] P. Painmanakul, J. Wachirasak, M. Jamnongwong, and G. Hébrard, "Theoretical prediction of volumetric mass transfer coefficient ( $k_L a$ ) for designing an aeration tank," *Engineering Journal*, vol. 13, no. 3, pp. 13-28, 2009.