

# ENGINEERING JOURNAL

*Article*

## Systematic Approach to Problem Solving of Low Quality Arc Welding during Pipeline Maintenance Using ARIZ (Algorithm of Inventive Problem Solving)

Trizit Benjaboonyazit

Faculty of Engineering, Thai-Nichi Institute of Technology, 1771/1 Pattanakarn Rd., Suanluang, Bangkok 10250, Thailand  
E-mail: [TriZit@gmail.com](mailto:TriZit@gmail.com)

**Abstract.** The pipelines in the oil and gas industry must be regularly checked for possible corrosion that might cause leakage of oil and gas. Magnetic flux leakage (MFL) technique is a magnetic method of nondestructive testing that is used to detect corrosion and metal loss in steel pipelines. The MFL device travels inside a pipeline to inspect the corrosion parts with a powerful magnet which is used to magnetize the pipe wall. At areas where there is corrosion or missing metal, the magnetic field leaks from the pipe wall and will be detected by magnetic sensors placed between the poles of the magnet and data is transmitted to the outside recording device for analysis. The problem occurs when it is necessary to remove the damaged segments of the pipe and replace them with the new ones by welding them to the existing pipelines. It is found that welding rod and arc column are subjected to some kind of force that causes them to deviate from the right position.

In this paper, the problem of low quality arc welding during pipeline maintenance due to residual magnetic field on the pipeline caused by MFL inspection device is systematically analyzed to find the root causes and ideal solution of which internal resources are utilized, is attained by using ARIZ (in this paper, magnetic field from welding current is selected). Computer simulation using finite element method and field test are conducted and show satisfactory result for the proposed idea.

**Keywords:** TRIZ, ARIZ, MFL, innovation tools, residual magnetic field, arc welding, pipeline maintenance.

ENGINEERING JOURNAL Volume 18 Issue 4

Received 28 January 2014

Accepted 23 June 2014

Published 16 October 2014

Online at <http://www.engj.org/>

DOI:10.4186/ej.2014.18.4.113

## 1. Introduction

In the present world of modern society and advance technology with growing concern on environment, the pipelines in the oil and gas industry must be regularly checked for possible corrosion that might cause leakage of oil and gas. Magnetic flux leakage (MFL) technique is a magnetic method of nondestructive testing that is used to detect corrosion and metal loss in steel pipelines. In this technique, the MFL device, typically known as a "PIG" travels inside a pipeline to inspect the corrosion parts with a powerful magnet which is used to magnetize the pipelines. The wall of the pipeline is magnetized axially to near saturation flux density. If, at some point, the wall thickness is reduced by a defect or corrosion, a higher fraction of the magnetic flux will leak from the wall into the air. The magnetic flux leakage will be detected by magnetic sensors placed between the poles of the powerful magnet and data are sent to the outside recording device for analysis. Analysts interpret the chart recording of the leakage field to identify damaged areas and estimate the depth of metal loss for maintenance. Experiments and numerical simulation of magnetic flux leakage inspection in pipeline steel with 3D finite element method have been carried out to prove the effectiveness of this technique of MFL [1].

Problem occurs when it is necessary to remove the damaged segment of the pipe and replace it with the new ones by welding them to the existing pipelines. It is found that welding rod and arc column are subjected to some kind of force that causes them to deviate from the right position and sometime the arc is even blown away. This phenomenon is known as the magnetic arc blow problem where the cause of it is explained as the interaction between the magnetic field of the welding arc and the field of the residual magnetism which may result in poor quality welding [2]. The residual magnetic fields generating magnetic arc blow have been determined in scientific investigations and confirmed by practical experience. It has been established that in the range from 0 to 2 mT (0 to 20 Gauss), the intensity of the magnetic arc blow is very low and has no influence on the welding process. The effect of magnetic arc blow becomes evident in the range from 2 to 4 mT (20 to 40 Gauss), but the effect may be eliminated by simple measures (the variation of the point of connection of the return conductor, welding current, the angle of inclination of the electrode). In the presence of the magnetic fields in a welding gap with a residual magnetism of more than 4 mT (40 Gauss), it is necessary to demagnetize the welded component or welded section [3]. Many methods have been suggested to overcome arc blow problem such as using C-shape permanent magnet placed across the weld joint to compensate for the residual magnetic field [3], or using ground lead of DCEN welding machine wrapped over the pipe to generate compensating magnetic field [4]. But there is no clear explanation on how these methods were derived and whether there are any other potential solutions for the problem.

In this paper, the problem of low quality arc welding during pipeline maintenance due to residual magnetic field on the pipeline caused by MFL inspection device of an oil and gas exploration and production company in Thailand is systematically analyzed by deploying the method of function analysis and cause effect chains analysis to find the root causes of the problem and ideal solution of which internal resources are utilized is searched for by using ARIZ. Finally, computer simulation using finite element method and field test are conducted to evaluate the proposed idea.

Besides, this paper also aims to prove TRIZ's effectiveness in idea generation and systematic innovation using the problem of low quality arc welding during pipeline maintenance due to residual magnetic field on the pipeline caused by MFL inspection device as a case study.

## 2. Description of the Methodology

The methodology used in this paper is comprised of FA (Function Analysis) CECA (Cause Effect Chains Analysis) and ARIZ (Algorithm of Inventive Problem Solving). FA and CECA are used to analyze the problem to find key problem after which ARIZ is deployed to solve it and search for ideal solutions.

ARIZ is a step-by-step method of analyzing a problem for the purpose of revealing, formulating, and resolving contradictions. ARIZ was developed by Genrikh Altshuller who is the founder of TRIZ. TRIZ (pronounced TREEZ) is the Russian acronym for the Theory of Inventive Problem Solving. It began in 1946 when the Russian scientist Genrikh Altshuller studied thousands of patents and noticed certain patterns. From these patterns he discovered that the evolution of a technical system is not a random process, but is governed by certain objective laws. He developed various innovation tools for solving inventive problems which involve at least one contradiction which can be resolved without compromising

or trade-off by using the 40 inventive principles, principles of separation [5] and 76 standard solutions [6]. ARIZ was later developed to tackle complex problems by combining all the innovation tools in a systematic way which is explained in details in section 4.

### 3. Problem Analysis

#### 3.1. Initial Problem Situation

Pipelines maintenance of an oil and gas exploration and production company in Thailand is conducted at an onshore crude oil transportation pipeline site as shown in Fig. 1. An MFL device with strong magnetic field is used to magnetize the pipe wall to nearly saturation level while traveling through the pipelines. Magnetic field leakage at the corrosion part will be detected by magnetic sensors on the MFL device. After corrosion part of the pipeline is located, the damaged segment is cut off and replaced with the new one by welding them to the existing pipeline, the welding engineer of the company experiences difficulty in maintaining the position of welding rod and arc column which is subjected to some kind of force that causes it to deviate from the right position, thus render the low quality of arc welding.

The pipeline is made of carbon steel API5L-X42 with outside diameter as 6 inch and wall thickness as 6.35 mm. The welding process is Shielded Metal Arc Welding (SMAW) on DC type arc welding machine with Electrode Positive (DCEP). The welding rod is of 3.2 mm in diameter and the welding current is in the range of 90-130 A. The weld joint is prepared by furnishing the pipe with squared ends and beveled edges so that, when placed with ends about 1/16-inch apart, there is a V-groove all the way around the joint where the welding metal is applied. The groove angle is about 75 degrees for pipe with a wall thickness of 1/4 inch or less as stated in the Standards for pipeline welds [7].



Fig. 1. Pipeline maintenance at an onshore crude oil transportation pipeline site.

#### 3.2. Function Analysis and Cause-Effect Chains Analysis

Function Analysis and Flow Analysis are used to analyze the system by which Function model is created to analyze the functions of all the components in the system after which Cause-Effect Chains Analysis is used to identify the key problems.

The process of SMAW arc welding can be described as shown in Fig. 2. as follows: electric power source supplies current to the welding rod through electrode lead and welding clip, the current flows through the arc column to the pipe and returns to power source through grounding clamp and grounding wire. The arc column is started by tapping or scratching the welding rod against the pipe to create short circuit where large current flow causes high temperature at contact point. When welding rod departs from pipeline, the heat and electric field at the contact point will causes air between welding rod and pipe to ionize and become conductive, the current will flow through the conductive plasma, causing it to become arc column. The heat from the arc column will melt the welding rod to create weld bead which will join the heated pipelines together [8].

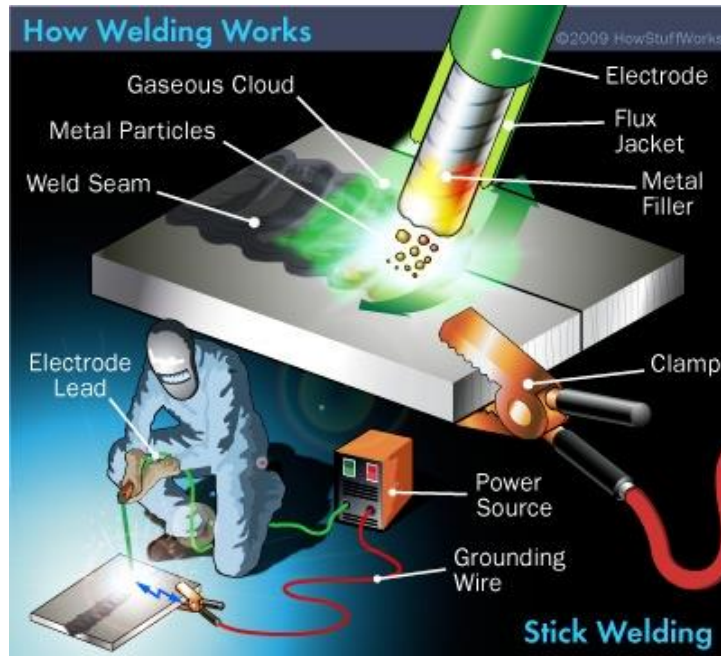

Fig. 2. The process of arc welding (HowStuffWorks [8]).

Components in the pipeline welding system are listed as in Table 1.

Table 1. Components in the pipeline welding system.

Engineering System	Components	Super System Components
Pipeline welding system	Pipeline Welding rod Arc column Power source Electrode lead Grounding wire Grounding clamp Welder's hand Air Electric current Electric field Magnetic field Heat (Thermal field) Weld bead Residual magnetic field	MFL Inspection Device

The current in the pipeline welding system will pass through the components as shown in Fig. 3.

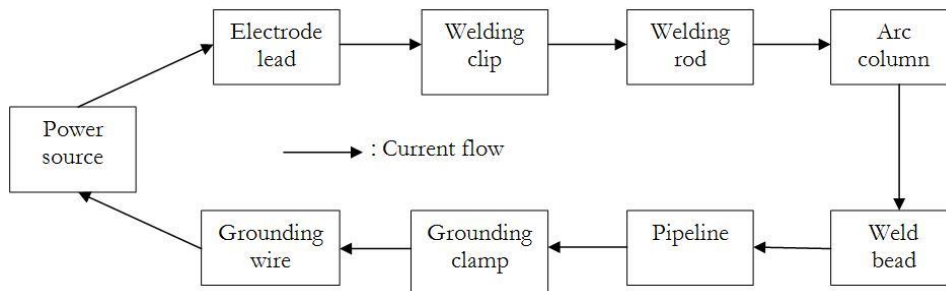

Fig. 3. Flow Analysis of current in pipeline welding system.

Function Model is created to analyze the interaction or function among each component in the pipeline welding system. It is found that the current flow in the welding rod and arc column will create magnetic field around them which will interact with the residual magnetic field in the pipeline caused by MFL device or "PIG" under the non-destructive inspection process as shown in Fig. 4.

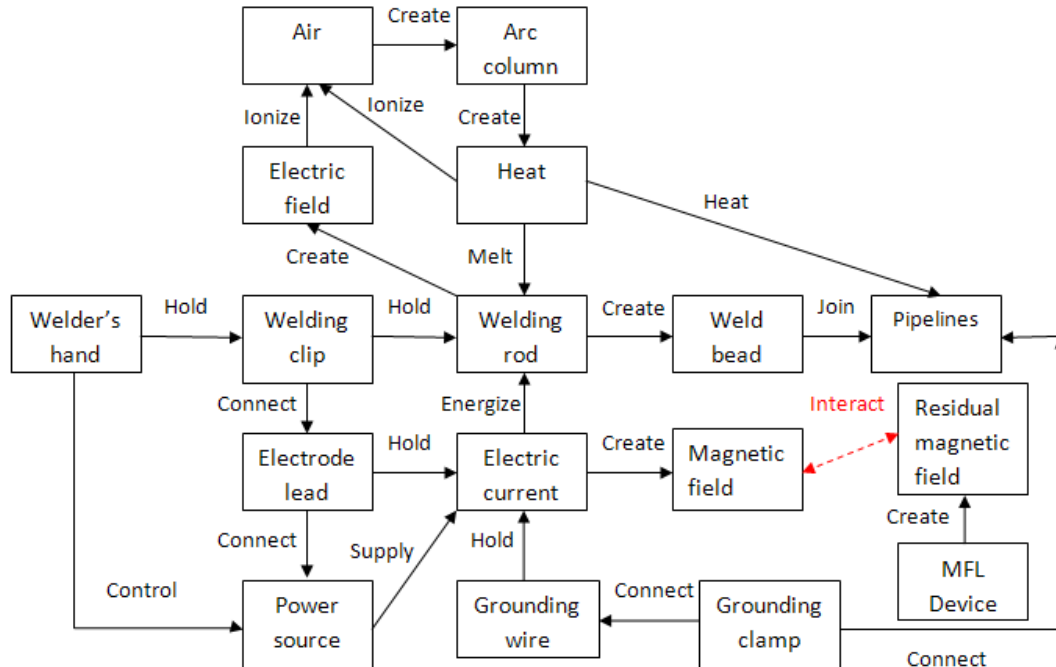

Fig. 4. Function Model of the pipeline welding system.

Cause-Effect Chains Diagram is created to analyze the root cause of the problem. The problem or Target Disadvantage is the low quality of welding. Cause-Effect Chains Analysis is applied to identify Key Disadvantages or root causes and the Key Disadvantages are identified as MFL running through the pipeline and Current flow in arc column as shown in Fig. 5 which suggests us to change to different non destructive inspection system and welding system. But since it is difficult to change the method of MFL non-destructive inspection system and the electric arc welding system, the Key Disadvantages is considered as residual magnetic field in pipeline and magnetic field around arc column which combine to create unbalance of magnetic flux around the arc column which is the key problem that make arc column deviated from the right position and renders low quality of welding.

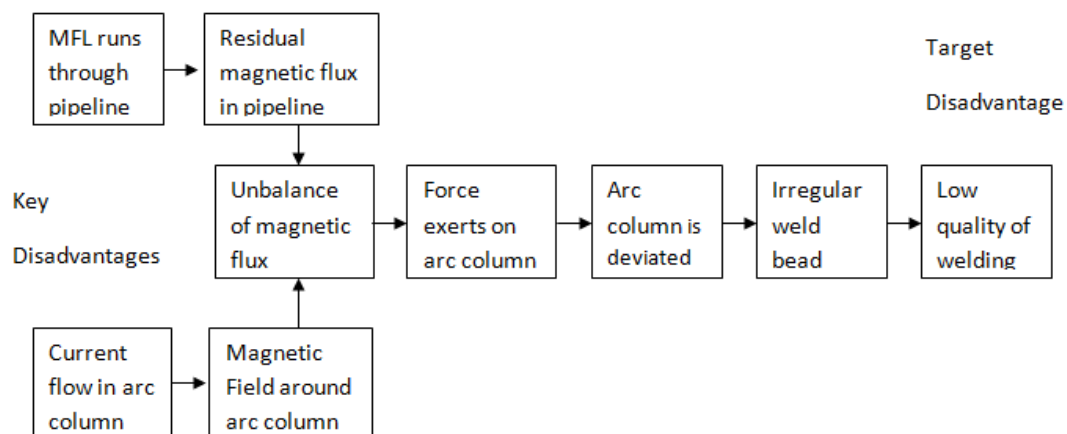

Fig. 5. Cause-Effect Chains Diagram of the problem of low quality of welding.

## 4. Problem Solving with ARIZ

From problem analysis, the Key Disadvantages are identified as residual magnetic field in pipeline and magnetic field around arc column which combine to create unbalance of magnetic flux around the arc column which is the key problem that make arc column deviated from the right position and renders low quality of welding. In order to get an ideal solution, it is preferable to consider using existing available resources in the system to solve the problem instead of importing from outside the system which may be costly. Since TRIZ's concept of resources is one of the important parts in the Algorithm of Inventive Problem Solving (ARIZ) [9], ARIZ is applied to systematically analyze the problem and search for potential solutions.

ARIZ was developed by Genrikh Altshuller, the founder of TRIZ (born Tashkent, Uzbek SSR, USSR, 15 October 1926; died Petrozavodsk, Russia, 24 September 1998) The last version of ARIZ is ARIZ-85C which contains 9 parts and totally 40 steps [10,11] as follows:

- Part 1. Analyzing the Problem
- Part 2. Analyzing the Problem Model
- Part 3. Formulating the Ideal Final Result and Physical Contradiction
- Part 4. Mobilizing and Utilizing Substance-Field Resources
- Part 5. Applying the Knowledge Base
- Part 6. Changing or Substituting the Problem
- Part 7. Analyzing the Method for Resolving the Physical Contradiction
- Part 8. Capitalizing on the Solution Concept
- Part 9. Analyzing the Problem-Solving Process

ARIZ has been applied in many engineering systems to solve various problems for systematic innovation. Recently, ARIZ has also been utilized in non-technical systems to solve management problem and agricultural problem [12]. The problem of low quality of welding is analyzed systematically step by step using ARIZ as below to generate ideas at each step for possible solutions. All the ideas will be reviewed at the end to look into their possibility and suitability, some suitable ideas will be selected as potential solutions to be tested and evaluated.

### 4.1. Part 1. Analyzing the Problem

#### Step 1.1 Formulate the mini-problem.

The pipeline welding system has the main function of joining the pipelines after replacing the corrosion segment with the new one. The main components of the system consist of MFL device, Residual magnetic field, Arc welding machine, Pipeline, Welding rod, Arc column.

Mini-problem can be formulated as follows:

It is necessary, with minimum changes to the system, to maintain the residual magnetic field for detecting corrosion part during non-destructive inspection process without deviating the arc column during the arc welding process.

#### Step 1.2 Define the conflicting elements.

The Conflicting Elements includes Product and Tool which, in this case, are defined as follows:

Products: Detecting corrosion part and Deviating arc column

Tool: Residual magnetic field

#### Step 1.3 Build graphical models for the technical contradictions.

Technical Contradictions (TC) are formulated as follows:

TC-1: If the Residual magnetic field is strong, it is easy to detect corrosion part, but the arc column will be deviated.

TC-2: If the Residual magnetic field is weak, the arc column can be positioned correctly, but it is difficult to detect corrosion part.

The Graphical Models for the Technical Contradictions are built as shown in Fig. 6.

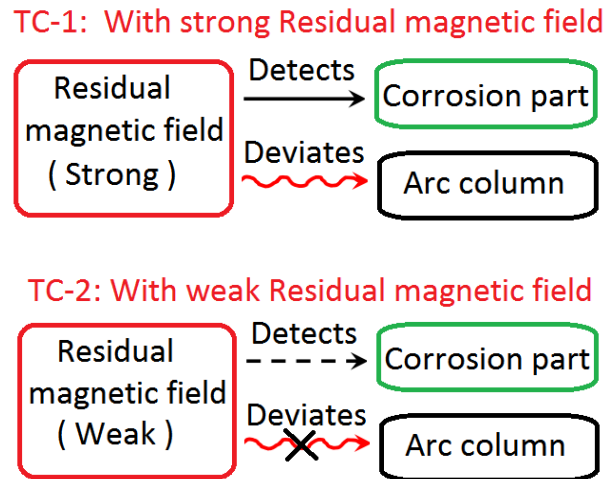

Fig. 6. Graphical models for the technical contradictions.

**Step 1.4** Select a graphical model for further analysis.

Since the main function of the pipeline welding system is joining the pipelines with good quality of welding, the arc column must not be deviated by Residual magnetic field. Thus, we should choose TC-2 which states that with weak Residual magnetic field, the arc column can be positioned correctly, but it is difficult to detect corrosion part. This is impossible without changing the mechanism of MFL device which goes beyond the mini problem defined in Step 1.1

Thus, we try to look at the problem from another direction. TC-1 is selected as Graphical Model for further analysis. In this case, with strong Residual magnetic field, it is easy to detect corrosion part, but the arc column will be deviated. So we try to solve the problem of eliminating harmful effect of Residual magnetic field in the following steps.

**Step 1.5** Intensify the conflict.

In order not to compromise (trade off) useful function with harmful effect, we intensify the conflict by considering that instead of “Strong Residual magnetic field”, it is replaced by a “Very strong Residual magnetic field” in TC-1 as shown in Fig. 7.

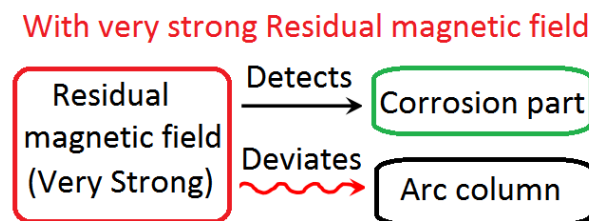

Fig. 7. Graphical models for the case of “very strong residual magnetic field”.

**Step 1.6** Formulate the problem model.

Find an element “X” that maintains the feature of the very strong residual magnetic field for detecting corrosion part during non-destructive inspection process while also protecting the arc column from being deviated during the arc welding process as shown in Fig. 8.

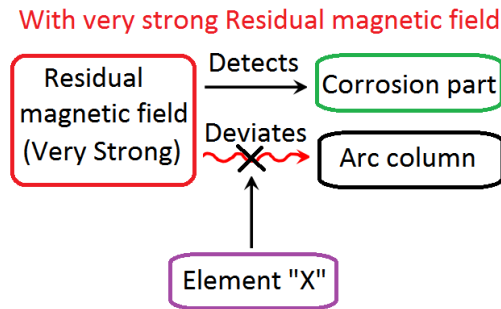

Fig. 8. Graphical models for new problem model.

**Step 1.7** Apply the system of standard solutions.

In this step the graphical model is analyzed using substance-field modeling and analysis [13] along with system of standard solutions [14] to find element “X” as follows:

The initial model is created with S1 as Pipeline, S2 as Arc column, F1 as Residual magnetic field and F2 as Welding current.

While welding Pipeline (S1 as an object) with Welding current (F2) through Arc column (S2 as a tool), Residual magnetic field (F1) causes a harmful function by exerting its force through the pipeline to deviate the arc column. The useful function (weld) becomes insufficient (Dashed line) as shown in Fig. 9.

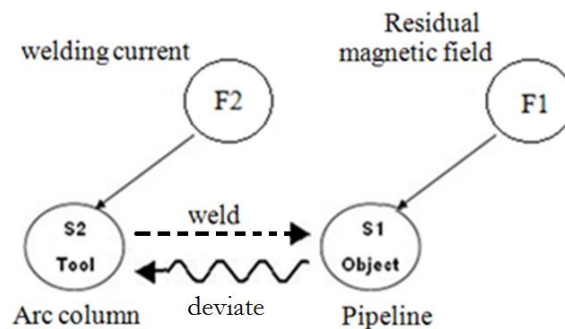

Fig. 9. Substance-field modeling and analysis.

In order to eliminate the harmful effect in the system, the system of standard solutions class 1.2 are considered and it is found that the standard solution which corresponds to the above initial model is standard solution 1.2.5 which states as follows:

Standard solution 1.2.5 “Switching Off” a Magnetic Influence (as shown in Fig. 10)

If it is necessary to eliminate the harmful effect of a magnetic field in a Substance-Field Model, the problem can be solved by applying the physical effects which are capable of “switching off” the ferromagnetic properties of substances, for example, by demagnetizing during an impact or during heating above the Curie point.

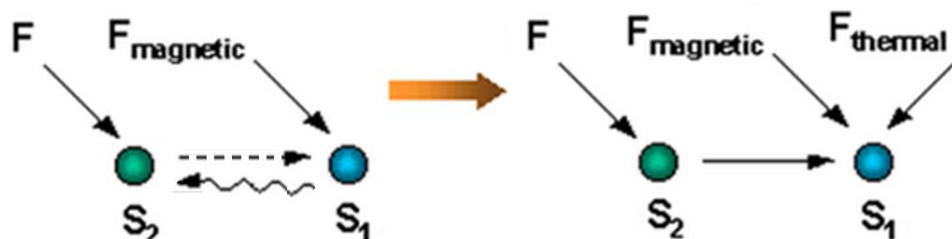

Fig. 10. Standard solution 1.2.5 “Switching Off” a magnetic influence.

Standard solution 1.2.5 gives us a hint to find some other fields to destroy the residual magnetic field in the pipeline. Several ideas are generated as follows:



**Idea 1:** Use thermal field.

Heat the pipe above its Curie point so that it might lose its ferromagnetic properties.

**Idea 2:** Use mechanical field.

Strike the pipe with a hammer. This might destroy the alignment of the residual magnetic field in the pipeline.

**Idea 3:** Use magnetic field.

Use permanent magnet to rub the pipeline. This might demagnetize the residual magnetic field in the pipeline.

**Idea 4:** Use electric field.

Use an alternate current solenoid to alter the magnetic dipole's order. This might destroy the alignment of the residual magnetic field in the pipeline.

### Evaluation

After doing some field-test. It is found that all the methods in the above ideas are not practical to be implemented. Although they can be applied to a small permanent magnet, but the structure of the magnetized steel pipeline is too large to use the methods of heating, hammering, rubbing or using alternate current solenoid to remove the residual magnetic field in the pipeline.

## 4.2. Part 2. Analyzing the Problem Model

If the problem is easily solved within Part 1, there is no need to go further into Part 2. Part 2 and other Parts that follow will deal with solving complex problem as in the following steps.

**Step 2.1** Define the operational zone (OZ).

In the problem of pipeline welding system, the Operational Zone is defined to be the place around the welding zone between welding rod and pipeline.

**Step 2.2** Define the operational time (OT).

In the problem of pipeline welding system, the Operational Time is defined to be the sum of the period of time before the welding ( $T_1$ ) and the period of time during the welding ( $T_2$ ) where conflict occurs during the welding time as shown in Fig. 11.

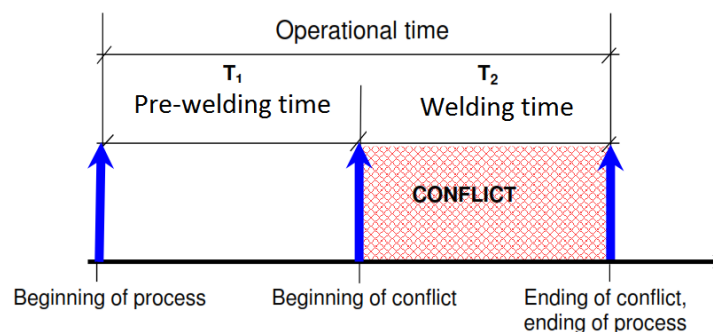

Fig. 11. Operational time.

### Step 2.3 Define the substance field resources.

The main idea of using substance-field resources is to use any changes in parameters of existing system substance and field resources (including the natural environment) for system problem solving and development [15, 16].

Substance-field resources are substances and fields that are already available or may be easily produced under problem conditions. There are two types of substance-field resources: internal system substance-field resources and external system substance-field resources.

At this state, we create a list of Substance-Field Resources with their parameters as in Table 2.

Table 2. Substance-field resources.

Substance-Field Resources	Type	Parameters
Heat from the welding current	Field	Temperature
Magnetic field from welding current	Field	Intensity, Direction
Welding current	Field	Amplitude, Frequency
Electrode lead	Substance	Length, diameter, conductivity
Pipeline	Substance	Length, diameter, conductivity
Earth Magnetic line	Field	Intensity, Direction
Gravity	Field	Weight

### 4.3. Part 3. Formulating the Ideal Final Result and Physical Contradiction

#### Step 3.1 Identify the formula for IFR-1.

Ideal Final Result (IFR) is used to define the problem to be solved [17]. The Ideal Final Result by introducing the X element is defined as follows:

While neither complicating the system nor causing harmful effects, element “X” eliminates the harmful effect of the very strong residual magnetic field to deviate the arc column during operational time within the conflict zone while preserving the ability of the very strong residual magnetic field to detect corrosion part of the pipeline during non-destructive inspection process as shown in Fig. 12.

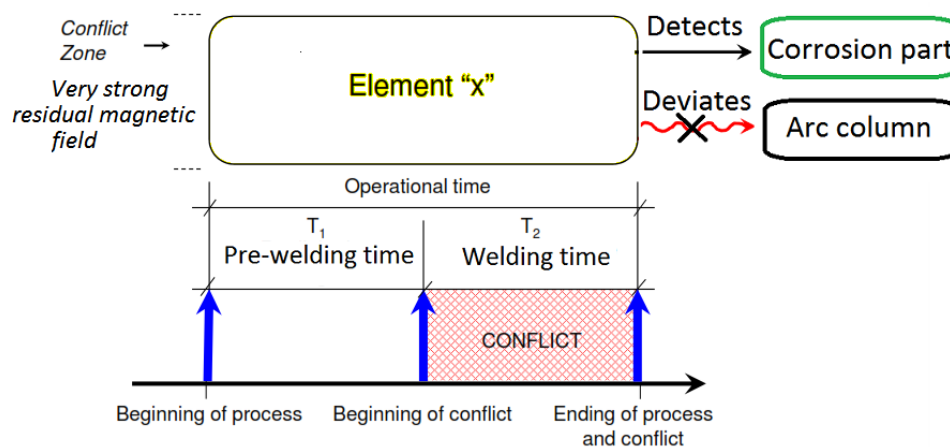

Fig. 12. Ideal Final Result (IFR-1).

#### Step 3.2 Intensify the formula for IFR-1.

We intensify the formula of IFR-1 by introducing an additional requirement that the X element comes from substance field resources. In this case, “Magnetic field from welding current” is considered first with its parameter intensity and direction to replace the X element.

IFR-1: While neither complicating the system nor causing harmful effects, “Magnetic field from welding current” with proper intensity and direction eliminates the harmful effect of the very strong residual magnetic field to deviate the arc column during operational time within the conflict zone while

preserving the ability of the very strong residual magnetic field to detect corrosion part of the pipeline during non-destructive inspection process as shown in Fig. 13.

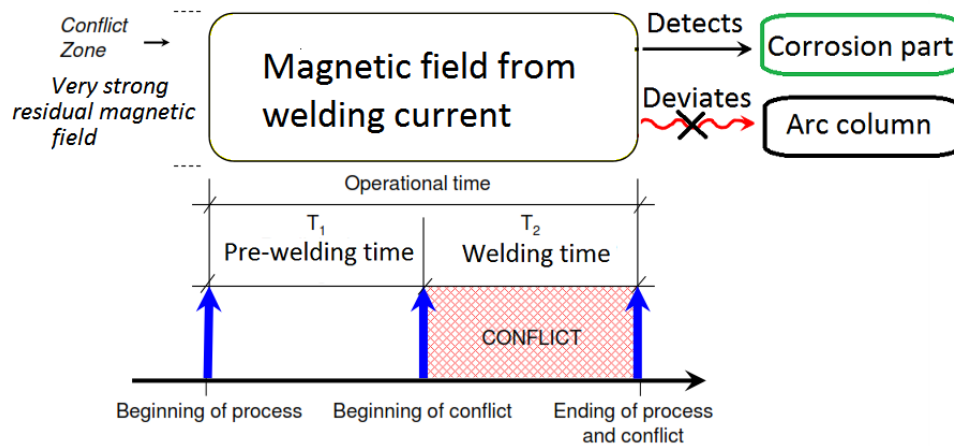

Fig. 13. Intensified formula for IFR-1.

### Step 3.3 Formulate the physical contradiction for the macro-level.

The Physical Contradiction [18] for the Macro-Level is formulated as follows:

“Magnetic field from welding current” should have proper intensity and direction during welding time to eliminate the harmful effect of the very strong residual magnetic field, and should have no intensity and direction during pre-welding time to preserve the ability of the very strong residual magnetic field to detect corrosion part as shown in Fig. 14.

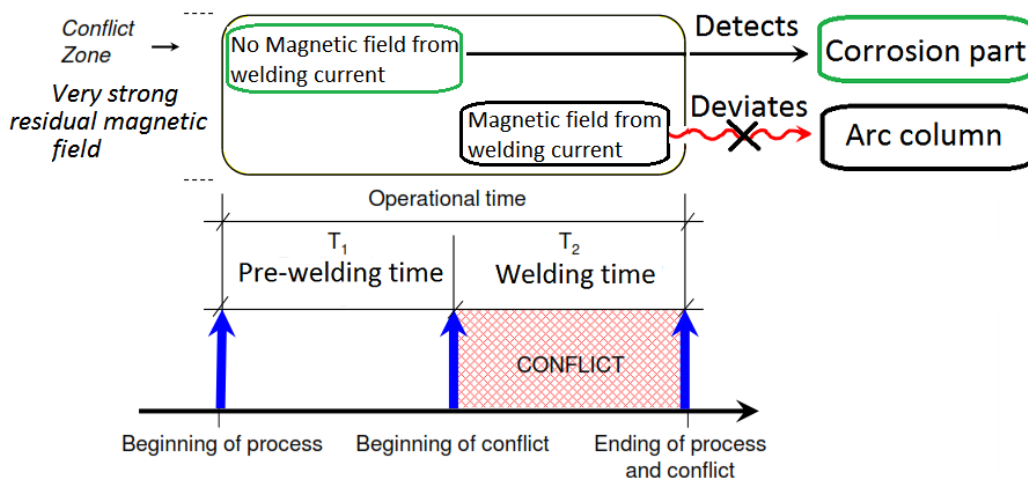

Fig. 14. Physical contradiction for the macro-level.

At this state we cannot come up with any ideas, we then go further into next step to look at the Physical Contradiction for the Micro-Level.

### Step 3.4 Formulate the physical contradiction for the micro-level.

The Physical Contradiction for the Micro-Level is formulated as follows:

“Free electrons” should flow around the pipe in the conflict zone to create proper intensity and direction of magnetic field during welding time to eliminate the harmful effect of the very strong residual magnetic field, and should not flow around the pipe in the conflict zone during pre-welding time to preserve the ability of the very strong residual magnetic field to detect corrosion part as shown in Fig. 15.

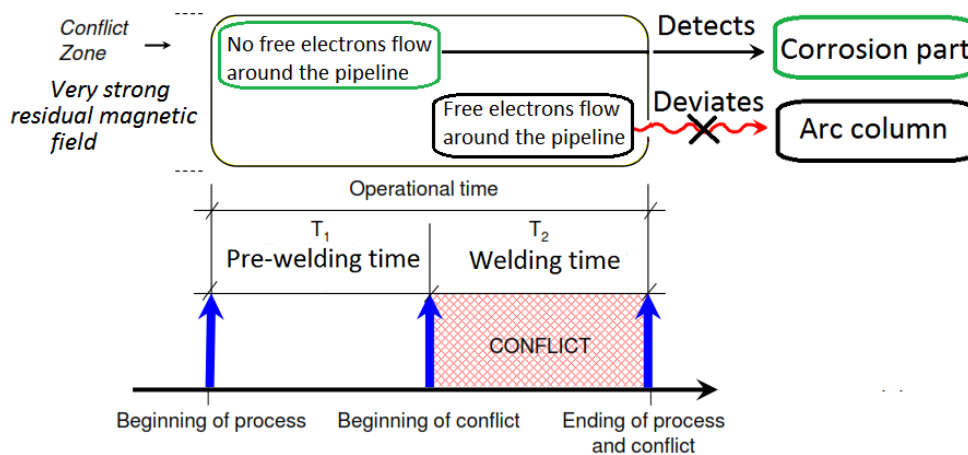

Fig. 15. Physical contradiction for the micro-level.

### Step 3.5 Formulate the ideal final result (IFR-2).

The Ideal Final Result (IFR-2) from the Physical Contradiction for the Micro-Level is formulated as follows:

IFR-2: “Free electrons” should, on their own, flow around the pipe in the conflict zone to create proper intensity and direction of magnetic field during welding time to eliminate the harmful effect of the very strong residual magnetic field, and should be, on their own, neutralized during pre-welding time to preserve the ability of the very strong residual magnetic field to detect corrosion part.

### Step 3.6 Consider solving the new problem using the system of standard solutions.

Consider Solving the New Problem in Step 3.5 using Standard solution 1.2.5 once again with magnetic field from welding current as resource to generate ideas.

Standard solution 1.2.5 “Switching Off” a Magnetic Influence: which states that If it is necessary to eliminate the harmful effect of a magnetic field in a Substance-Field Model, the problem can be solved by applying the physical effects which are capable of “switching off” the ferromagnetic properties of substances, for example, by demagnetizing during an impact or during heating above the Curie point.

#### Idea 5: Use “Magnetic field from welding current”.

Magnetic field from welding current is a derived resource in the system and can be utilized to counteract the residual magnetic field in the pipeline locally at the welding zone during the welding time. By winding the electrode lead and grounding wire around the pipe near the welding zone with proper amount of turns and direction, the free electrons will, on their own, flow around the pipe in the conflict zone to create proper intensity and direction of magnetic field during welding time as soon as the arc column is initiated, and during the non-destructive inspection process before the welding time, no free electron is flowing around the pipe, thus, the ability of the residual magnetic field to detect corrosion part can be preserved.

Although we use the same Standard solution 1.2.5 as in Step 1.7, the difference is that with all the substance field resources at hand, we can have a deeper insight into how the problem could be solved ideally. Besides, TRIZ’s Inventive Principle [5] Number 3 ‘Local Quality’ helps us to overcome our psychological inertia [6] by giving a hint that instead of demagnetizing the entire pipeline, we can just demagnetize only the welding zone locally.

We also look for other ideas by going back to Step 3.2 and replace X element with other substance field resources such as heat from welding current and repeat the process of part 3 again to get the idea of heating the welding zone locally which might neutralize the residual magnetic field. (**Idea 6**).

Idea 5 of using “Magnetic field from welding current” to counteract the residual magnetic field in the pipeline is considered to be more suitable and is adopted as potential solution to be evaluated with computer simulation and field test later in this paper. Since we are satisfied with the ideas we have already generated, other parts of ARIZ can be skipped [19]. But as the founder of TRIZ (Altshuller) highly recommends us to drive ARIZ up to the end to review the solutions, the initial problem and the ARIZ

process itself, we go further into the rest of ARIZ to look for other solutions. But due to limited space, only relevant steps of each part will be explained as below.

#### 4.4. Part 4. Mobilizing and Utilizing Substance-Field Resources

In this part, we try to find other solutions by mobilizing and utilizing Substance-Field Resources to generate more ideas as follows:

##### Step 4.1 Simulation with smart little people.

Smart Little People technique is used to prevent psychological inertia by forcing people to imagine the components of the system in the conflict zone as smart little creatures interacting with each other.

The problem of low quality arc welding on pipeline can be simulated with Smart Little People as follows:

Smart Little People (SLP) of arc column is surrounded and pushed by SLP of magnetic flux around it. When there is no unbalance of magnetic flux around arc column, the arc column is not pushed away from its original position as in Fig. 16(a), but when there is unbalance of magnetic flux around arc column, the arc column is pushed away from the right position as in Fig. 16(b), making it difficult to maintain good quality of arc welding.

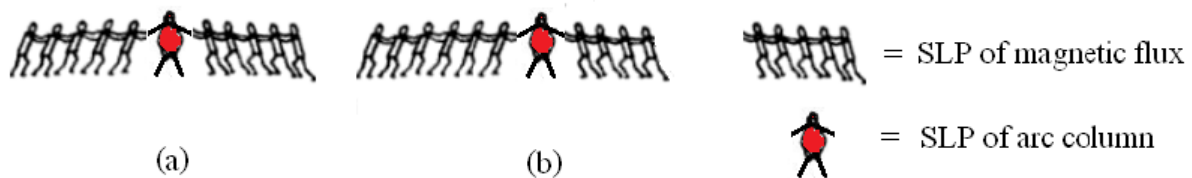

Fig. 16. Smart Little People (SLP) of components of the system in the conflict zone; (a) with no unbalance of magnetic flux around arc column; (b) with unbalance of magnetic flux around arc column.

With the observation at the micro level of the system through SLP, it gives us some hints to solve the problem, for example, SLP of arc column should lean towards SLP of more magnetic flux, using its weight (Gravitational field) to counteract the unbalanced pushing force around it as in Fig. 17.



Fig. 17. SLP of arc column leans towards SLP of more magnetic flux.

**Idea 7:** Adjust the angle of inclination of the electrode in the direction that helps lessen the effect of unbalance of magnetic flux around arc column

This is what is really implemented in the case of little unbalance of magnetic flux around arc column. For strong unbalance of magnetic flux around arc column like that generated from strong residual magnetic flux, it cannot counteract sufficiently and more innovative solution is needed.

##### Step 4.6 Using an electrical field.

Electrical Field is considered, and ideas are generated as follows:

**Idea 8:** Use electric current to generate magnetic field to counteract residual magnetic field.

This step leads us to the same idea we have generated in Step 3.6

#### 4.5. Part 5. Applying the Knowledge Base

The purpose of Part 5 is to mobilize all experience accumulated in the TRIZ knowledge base. By using Effects Database, we come up with an idea as follows:

**Step 5.4** Consider resolving the physical contradiction by utilizing the library of natural effects and phenomena.

**Idea 9:** Use the effect of solenoid to demagnetize the pipeline before the welding process.

The AC mode of the existing welding machine can be use to energize the solenoid to create strong alternate magnetic field at the welding zone to destroy the alignment of the residual magnetic field in the pipeline.

#### 4.6. Part 6. Changing or Substituting the Problem

This part recommends us to reconsider the initial problem statement which might be created by psychological inertia.

**Step 6.3** If the problem is still not solved, change the problem by selecting another technical contradiction in Step 1.4.

We go back to the Cause-Effect Chains Diagram in Fig. 5 and find that the root cause of the problem is the unbalance of magnetic flux around arc column. So we select another Technical Contradiction in Step 1.4 as follows:

TC-1: If the magnetic field used in MFL Inspection Device is strong, it is easy to detect corrosion part, but the unbalance of magnetic flux is severe.

TC-2: If the magnetic field used in MFL Inspection Device is weak, the unbalance of magnetic flux is mild, but it is difficult to detect corrosion part.

We then repeat the process of ARIZ from Step 1.4 with new pair of Technical Contradiction selected above to find other solutions

Since the main function of the pipeline welding system is joining the pipelines with good quality of welding, the unbalance of magnetic flux should be mind, Thus, we should choose TC-2 which states that with weak magnetic field used in MFL Inspection Device, the unbalance of magnetic flux is mild, but it is difficult to detect corrosion part. This is impossible without changing the mechanism of MFL device which goes beyond the mini problem defined in Step 1.1

Thus, we try to look at the problem from another direction. TC-1 is selected as Graphical Model for further analysis. In this case, with strong magnetic field used in MFL Inspection Device, it is easy to detect corrosion part, but the unbalance of magnetic flux is severe. So we try to solve the problem of eliminating harmful effect of strong magnetic field used in MFL Inspection Device.

We follow the steps of ARIZ and an idea comes up at Step 4.1. With the observation at the micro level of the system through SLP, it gives a hint to alternate the magnetic flux around arc column as in Fig. 18., with high speed so that arc column stays in the same place.

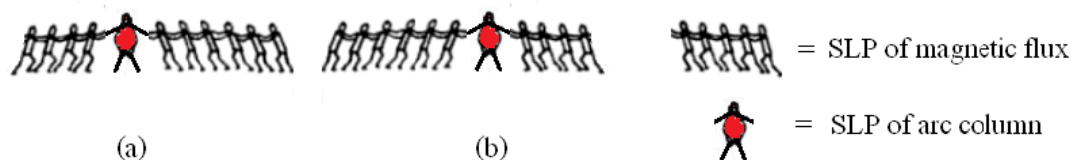

Fig. 18. Smart Little People (SLP) of components of the system in the conflict zone; (a) magnetic flux around arc column at one moment; (b) magnetic flux around arc column at the next moment.

**Idea 10:** Use Alternating Current (AC) instead of Direct Current (DC) welding machine.

The 50/60 Hz Alternating Current will alternate the magnetic flux around arc column fast enough that arc column is not deviated and the arc welding can be carried out with good quality. This idea is confirmed by the fact in the welding industry that the use of AC current markedly reduces arc blow as in [20]. But this might be difficult in case AC welding machine cannot be found to replace the DC welding machine which is already being used at the worksite.

#### 4.7. Part 7. Analyzing the Method for Resolving the Physical Contradiction

The main goal of Part 7 is to check the quality of the solution concept. The Physical Contradiction should be resolved almost ideally, without “cost.” using internal resources.

**Step 7.3** Check the novelty of the solution concept via a patent search.

The problem of arc blow during welding process has been studied for quite a long time ago and several relevant patents have been filed. Some interesting historical patents are listed as follows:

In 1930, Everett Chapman filed a patent titled “Arc welding” in which electromagnet from outside was introduced to compensate the unbalance of magnetic flux around arc column [21], but it was difficult to compensate correctly. Over and under compensation might happen and worsened the problem.

In 1959, Schultz Herold E filed a patent titled “Arc stray control” in which feed-back control mechanism was introduced to control the strength of magnetic field of electromagnet used for compensation [22], but the system was too complicated and difficult to use.

Later, in 2002, Ilich Abdurachmanov improved the feed-back control mechanism and filed a patent titled “Arc stray controlling welding apparatus” [23], but still the system is complicated and are not widely used.

The most recent patent is published in 2009 when John Holley invented an apparatus and filed a patent titled “Steel pipe demagnetizing tool” in which pre-fabricated demagnetizing coil structure is brought from outside to slide into the end of the pipeline and is energized using DC power source for 2-5 seconds. It is claimed that the surge of current through the Demagnetizing Tool removes from 92% to 100% of the magnetism from the weld area making it possible to make a successful weld without the problem of magnetism [24]. However, this process to demagnetize the end of steel pipe must be done before carrying the pipeline welding process and the residual magnetic field at the end of the pipe is not permanently removed. Depending upon the strength of the magnetic field in the middle portion of the pipe, the magnetic field will ‘creep’ back toward the ends of the pipe which might cause trouble to the welding process.

From the above patent search, we are convinced to claim that the engineering system we designed (Fig 19.) based on the solution concept we selected (Idea 5) is novel and innovative in term of its simplicity economy and ideality. Contrary to other solutions, there is no complicated parts or needs for outside resources. It utilizes all the internal resources existing in the system even the time resource which makes it possible to compensate the residual magnetic field at the same time during carrying welding process without the need for prior removal of residual magnetic field as in other patents.

#### 4.8. Part 8. Capitalizing on the Solution Concept

The purpose of Part 8 is to maximize the utilization of resources unveiled by the solution concept that has been found.

**Step 8.3** Apply the solution concept for solving other problems.

The solution concept derived in this paper can be applied to solve other problems related to using arc welding in steel structures which are subjected to residual magnetic field such as power plants, transportation systems, or bridge and building structure.

#### 4.9. Part 9. Analyzing the Problem-Solving Process

Part 9 suggests us to check our problem solving process and make a review on the ARIZ process itself for the next revisions of ARIZ.

**Step 9.1** Compare the real process of problem solving with the theoretical one (that is, according to ARIZ).

ARIZ was used in this project to analyze and solve the problem of low quality arc welding due to residue magnetic field in the pipeline. A lot of ideas are generated during the entire process of ARIZ from Part 1 to Part 9. Although in this project some irrelevant steps in Part 4 to Part 9 have been skipped, ARIZ has proved to be a strong innovation tool. ARIZ guides its users to look into the initial situation, create problem models based on contradictions in the system and solve the problem using relevant TRIZ tools to generate solution concepts. ARIZ also provides a feedback loop for users to review the initial situation and reconsider system contradictions to get new problem models for idea generation. In this project, FA and CECA are used to analyze the problem to find key problem after which ARIZ is deployed. FA and CECA help clarify the initial situation and disclose appropriate contradictions. For more complex systems, recent works on “Problem Graph” [25] and “Contradiction Clouds” [26] might be helpful for problem formulation since it attempts to cover all aspects of problems and disclose all the system contradictions for problem solver to select the “most relevant” conflicting pair (TC1 & TC2). The next revisions of ARIZ should reflect the features of all these analyzing tools to make it more robust than intuitive.

### 5. Potential Solution

With all the ideal solution concepts (Idea 5, 6, 7, 8, 9, 10) generated along the process of ARIZ, Pugh Decision Matrix is deployed to select the most appropriate potential solution. With the recent patent of “Steel pipe demagnetizing tool” [24] as baseline, all the ideal solution concepts (Idea 5, 6, 7, 8, 9, 10) are evaluated against the criteria as in Table 3 below:

Table 3. Evaluation of the ideal solution concepts generated by the process of ARIZ.

Criteria	Baseline	Idea 5 (8)	Idea 6	Idea 7	Idea 9	Idea 10
1. Ideality	0	+1	+1	+1	+1	+1
2. Simplicity	0	+1	+1	+1	0	0
3. Economy	0	+1	+1	+1	+1	+1
4. Efficiency	0	+1	0	0	0	0
Total Score	0	+4	+3	+3	+2	+2

From Table 3., idea 5 of using “Magnetic field from welding current” to counteract the residual magnetic field in the pipeline is considered to be more suitable and is adopted as potential solution to be evaluated with computer simulation and field test. Since the arc welding machine is DC type with electrode positive (DCEP), the electrode lead and grounding wire can be wound around the pipe to generate constant magnetic field across the welding zone with the direction in accordance with the right hand rule. The intensity of magnetic field can be adjusted by adjusting the welding current and the number of turns of the electrode lead and the grounding wire on the pipe. With proper intensity and direction of the magnetic field, the residual magnetic field across the welding zone can be reduced to the value that it will no longer cause harmful effect to deviate the arc column which renders low quality of welding as shown in Fig. 19 where  $B_r$  stands for the residual magnetic field and  $B_i$  stands for magnetic field from welding current.



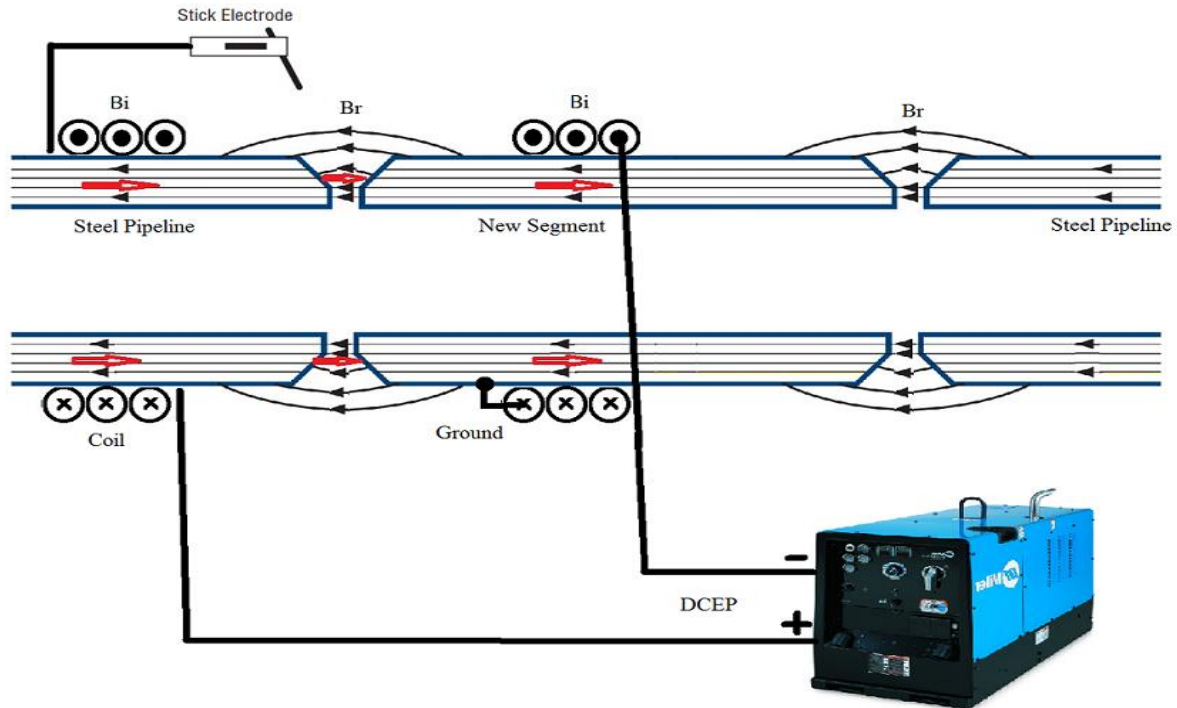

Fig. 19. Potential solution.

## 6. Magnetic Field Simulation and Field Test

For magnetic field simulation, the software of Finite Element Method Magnetics (FEMM) is used to develop an axisymmetric model of the pipeline with V-groove and coils on it. The pipeline model is divided into 3 parts with new segment that has no residual magnetic field in the middle. The other 2 parts of steel pipeline at both ends has residual magnetic field and acts like permanent magnets [27]. The magnetic property of the steel pipeline is assumed to have the same property as the test result from Southwest Research Institute [28] with BH Curve and coercivity as shown in Fig. 20.

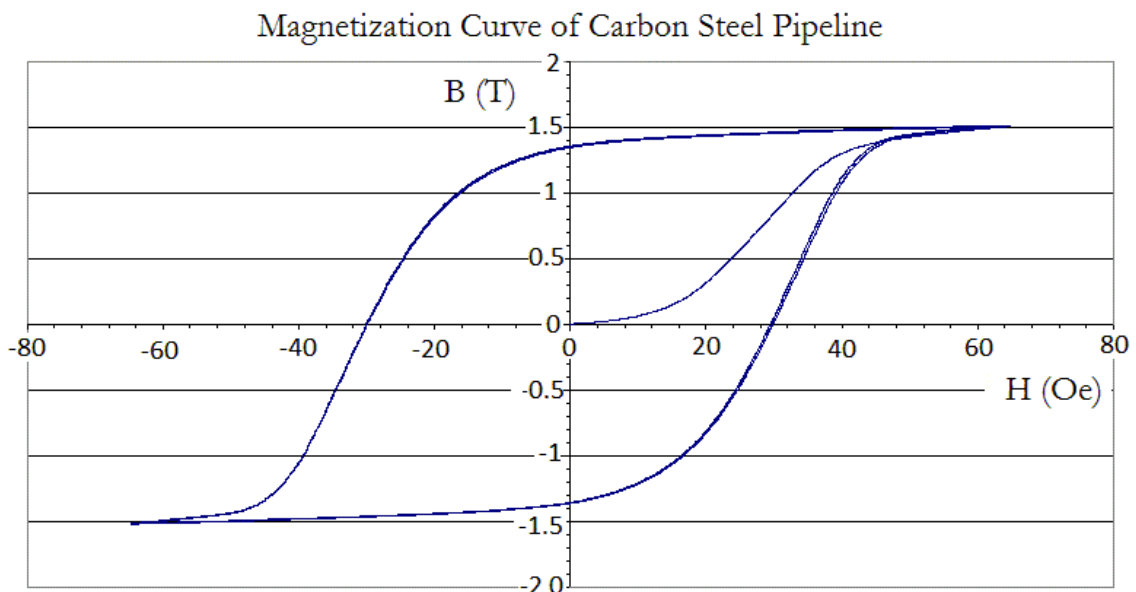

Fig. 20. Magnetic property of the carbon steel pipeline (API grades).

Since the corrosion part of steel pipeline is usually within 50 cm, the new segment of pipe for replacement is modeled as 50 cm long, and each of the 2 pipes with residual magnetic field at both ends is modeled as 125 cm long. The V-groove for welding between each segment is prepared according to the Standards for pipeline welds [7]. The result of magnetic field simulation with no compensation coils shows a large amount of magnetic flux leaking at the V-groove as shown in Fig. 21.

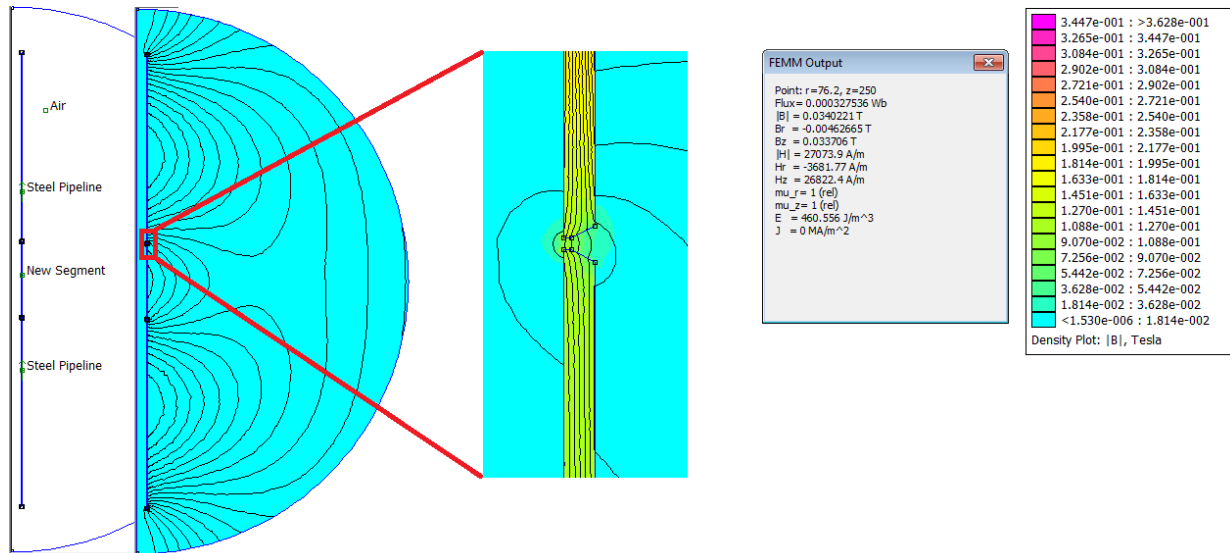

Fig. 21. Magnetic field simulation with no compensation.

With proper compensation coils, magnetic field simulation shows reduction in amount of magnetic flux leaking at the V-groove as shown in Fig. 22.

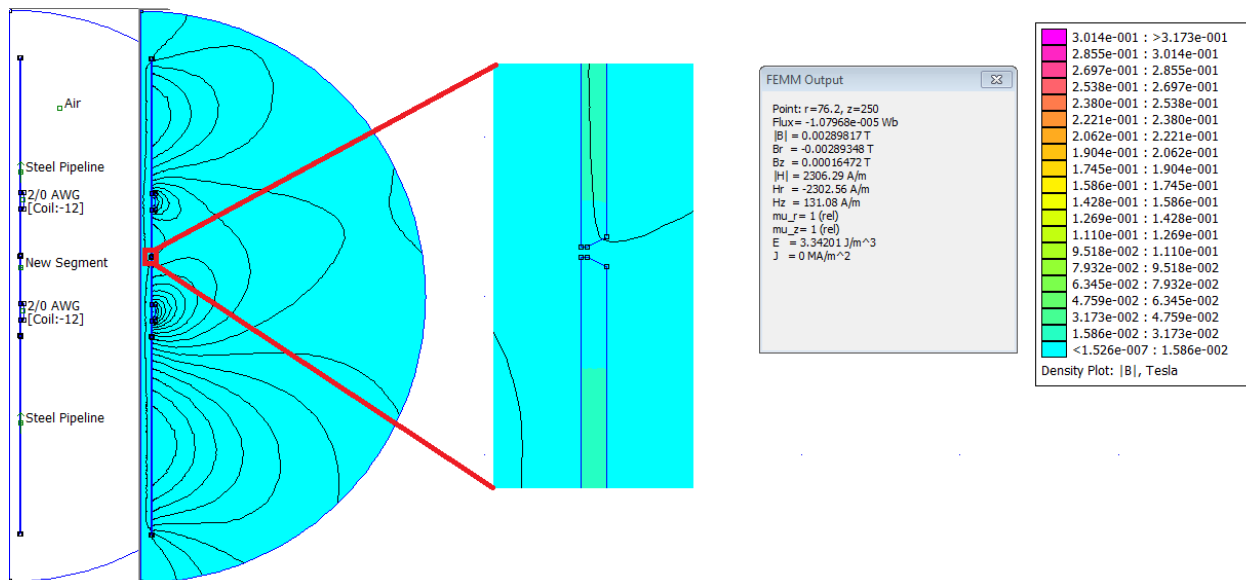

Fig. 22. Magnetic field simulation with compensation.

Magnetic field at the V-groove has different intensity depending on the location where it is measured. Fig. 23 shows the magnetic field variation at the V-groove (Bv) in the radial direction at different points located from the axis inside the pipe to outside space. On the left side of the figure is the case with no compensation coils and on the right side of the figure is the case with proper compensation coils. Without compensation coil, magnetic field at the root pass of the V-groove is as strong as 0.09 Tesla or 900 Gauss. And even at the pipe surface level, the magnetic field at the V-groove is as strong as 0.03 Tesla or 300 Gauss which is 10 times higher than the maximum permissible value of 30 Gauss needed to avoid arc blow

[4]. With proper compensation coils, magnetic field at the V-groove can be reduced to keep under the maximum permissible value of 30 Gauss as on the right side of the figure.

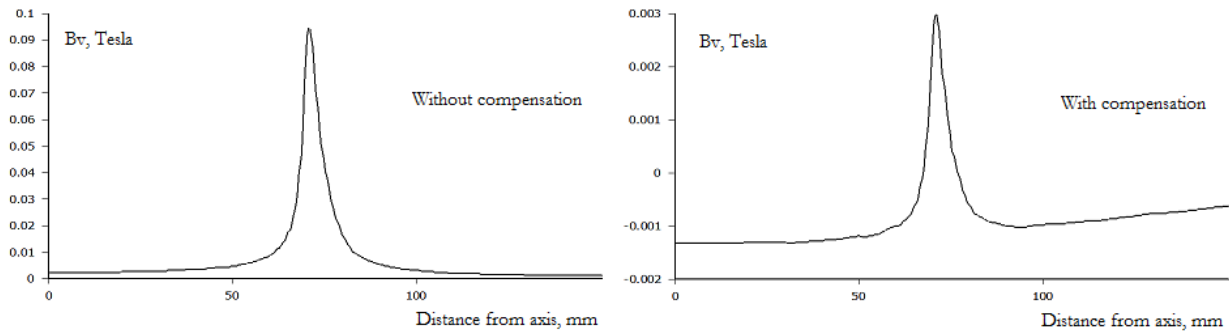

Fig. 23. Magnetic field variation at the V-groove from the axis inside the pipe to outside space.

In order to compensate for the residual magnetic field at the V-groove, suitable compensation magnetic field must be created with proper intensity and direction not to overcompensate or undercompensate. Magnetic field required to compensate for the given residual magnetic field at the V-groove varies with the type and size of the pipe, the position of the coil, the welding current that flows into the coil and the number of turns of the coil. As stated in the Initial Problem Situation, the problem occurs in pipelines maintenance at an onshore crude oil pipeline of an oil and gas exploration and production company in Thailand where carbon steel API5L-X42 with outside diameter as 6 inch and wall thickness as 6.35 mm are mostly used, there is no need to consider other variation. The position of the coils is considered to be fixed at 30 cm close to the V-groove on both sides for effective compensation without the risk of being melted away by the heat from arc column. And since the welding rod is of 3.2 mm in diameter and the welding current is in the range of 90-130 A, magnetic field simulation at the V-groove with compensation coils is conducted with the welding current and the number of turns as parameters. Resultant magnetic fields at the V-groove is calculated at different location in the V-groove as  $B_{vs}$  at the pipe surface level of the V-groove,  $B_{vm}$  at the middle of the V-groove, and  $B_{vr}$  at the middle of the root pass in the V-groove. The results are displayed as table and graphs in Fig. 24.

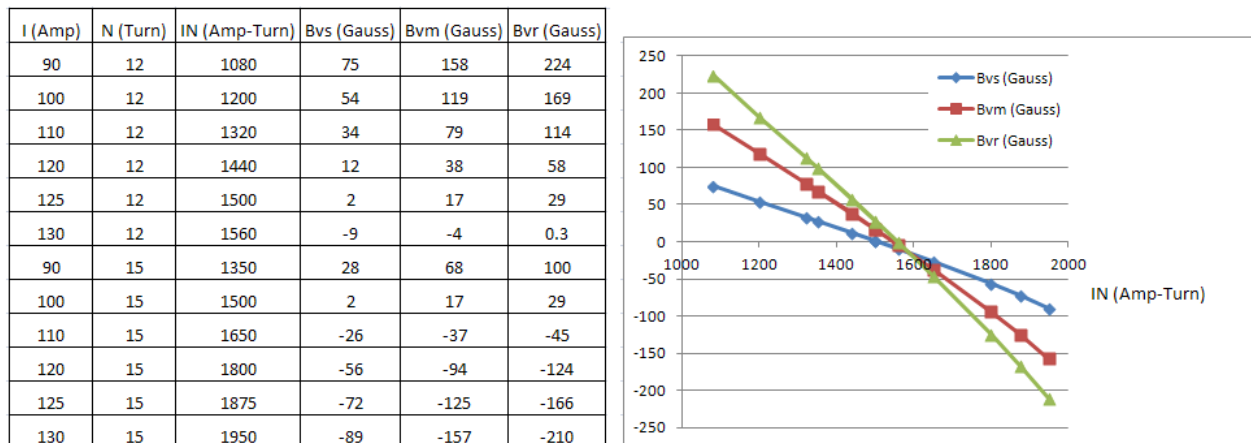

Fig. 24. The table and graphs of resultant magnetic fields at the V-groove.

Figure 24 shows that all the resultant magnetic fields at different location in the V-groove varies almost linearly to the product of current and number of turns which is the magnetomotive force and has the unit of Amp-turn. With low magnetomotive force, the magnetic field is undercompensated while with high magnetomotive force, the magnetic field is overcompensated. Both cases will yield the resultant magnetic field higher than 30 Gauss which will cause arc blow. From the graph in Fig. 24, the proper value of magnetomotive force that will not cause arc blow is around 1,440-1,650 Amp-turn for optimistic case scenario with  $B_{vs}$  calculated at the pipe surface level of the V-groove, and a narrow range of 1,500-1,560 Amp-turn for pessimistic case scenario with  $B_{vr}$  calculated at the middle of the root pass in the V-groove.

The welding engineer at the worksite can easily adjust the welding current and the number of turns to suit the optimal magnetomotive force with the formula  $I \cdot N = 1,500$  Amp-turn. At the field test, magnetomotive force of 1,500 Amp-turn with current setting at 100 A and 15 turns of coils on both side of the welding zone is used, the field test shows that the force exerting on arc column disappears and there is no more deviation of arc column which conforms with the magnetic field simulation and justifies the idea generated by ARIZ.

## 7. Conclusions

The problem of low quality arc welding during pipeline maintenance due to residual magnetic field on the pipeline caused by MFL inspection device of an oil and gas exploration and production company in Thailand is systematically analyzed by deploying the method of function analysis and cause effect chains analysis to find the root causes of the problem and ideal solution of which internal resources are utilized is searched for by using ARIZ. 10 ideas are generated during the process of ARIZ of which 5 ideas are ideal solutions using existing internal resources. The potential solution with the idea of using magnetic field from welding current to counteract residual magnetic field on the pipeline is proposed, and physical system is achieved by winding the electrode lead and grounding wire around the pipe near the welding zone with proper amount of turns and direction. Magnetic field simulation using finite element method shows that the optimal magnetomotive force of the coil which properly compensates the residual magnetic field at the welding zone is around 1,500 Amp-turn. The welding engineer at the worksite can easily adjust the welding current and the number of turns to suit the optimal magnetomotive force with the formula  $I \cdot N = 1,500$  Amp-turn. At the field test, magnetomotive force of 1,500 Amp-turn with current setting at 100 A and 15 turns of coils on both side of the welding zone is used, the result shows that the force exerting on arc column disappears and there is no more deviation of arc column which conforms with the magnetic field simulation and justifies the idea generated by ARIZ.

Although the solution in this paper is generated and designed to solve the problem on specific type and size of steel pipeline and with welding type as DCEP, the welding type of DCEN can also be applied and it can be easily extended to be used with other types and sizes of steel pipeline by finding the optimal magnetomotive force of the coil to counteract residual magnetic field on the pipe.

## Acknowledgements

The author would like to express his grateful thanks to Thai-Nichi Institute of Technology for their support in this research project, and also to PTT Exploration and Production Plc for their co-operation.

The author would also like to extend his sincere thanks to Dr. Mark Barkan who kindly advised him on how to use function analysis and cause-effect chains analysis, and also to TRIZ Master Vladimir Petrov who helped him review the process of ARIZ used in this paper.

Finally, the author wishes to thank Prof. Dr. Sergei Ikovenko, President of The International TRIZ Association (MATRIZ), who gave him the chance to present this project at The 10th MATRIZ International Conference.

## References

- [1] X.-B. Li, X. Li, L. Chen, P.-F. Feng, H.-D. Wang, and Z.-Y. Huang, "Numerical simulation and experiments of magnetic flux leakage inspection in pipeline steel," *Journal of Mechanical Science and Technology*, vol. 23, pp. 109–113, 2009.
- [2] J. Anderson. *State of the Arc: Magnetism in Pipes Can Stop Welding Progress* [Online]. Available: <http://www.engineerlive.com/content/22345>
- [3] V. V. Kozlov and I. V. Tret'yakov, "Using permanent magnets for preventing magnetic arc blow in repair of transmission gas pipelines," *Welding International*, vol. 21, no. 6, pp. 460–462, 2007.
- [4] J. H. E. Hernandez, F. Caleyó, G. L. R. Morales, and J. M. Hallen, A. L. Montenegro, and E. P. Baruch, "Method provides welders new technique for avoiding arc blow," *Oil & Gas Journal*, vol. 270, pp. 158-166, 21 Dec, 2009.
- [5] A. Genrich. "40 Principles," in *TRIZ Keys to Technical Innovation*. Worcester, Mass.: Technical Innovation Center, 1997, ch. 2, pp. 25-65. (Translated and edited by Lev Shulyak and Steven Rodman)

- [6] S. Kaplan, *An Introduction to TRIZ, the Russian Theory of Inventive Problem Solving*. Ideation International Inc., 1969.
- [7] Military Petroleum Pipeline Systems. *Standards for Pipeline Welds* [Online]. Available: <http://www.globalsecurity.org/military/library/policy/army/fm/5-482/Appb.htm>
- [8] How Stuff Works. *The Process of Arc Welding* [Online]. Available: <http://science.howstuffworks.com/welding2.htm>
- [9] G. Altshuller, B. Zlotin, A. Zusman, and V. Philatov “ARIZ,” in *Tools of Classical TRIZ*. Ideation International Inc., 1998, ch. 2, pp 20-68.
- [10] Isak Bukhman. *ARIZ-85C Algorithm for Inventive Problem Solving Structure* [Online]. Available: [http://www.triz.com.tw/isak2/tutorial/+ARIZ85C\\_structure\\_example\\_WEB\\_02\\_22\\_2012.pdf](http://www.triz.com.tw/isak2/tutorial/+ARIZ85C_structure_example_WEB_02_22_2012.pdf)
- [11] G. Altshuller. (1985). *ARIZ-85C*. [Online]. Available: <http://www.trizstudy.com/altshuller1985-ariz85c.html> (Translated and edited by Shinsuke Kuroswa, 2013)
- [12] T. Benjaboonyazit, “Systematic approach to arowana gender identification problem using algorithm of inventive problem solving (ARIZ),” *Engineering Journal*, vol. 18, no. 2, pp. 13-28, 2014.
- [13] I. Belski, *Improve Your Thinking: Substance-Field Analysis*. TRIZ4U., 2007.
- [14] John Terninko, Ellen Domb, Joe Miller (2000). *The Seventy-six Standard Solutions, with Examples* [Online]. Available: [http://www.triz-journal.com/archives/2000/02/g/article7\\_02-2000.PDF](http://www.triz-journal.com/archives/2000/02/g/article7_02-2000.PDF)
- [15] G. Cameron, “Substance-field resources,” in *Trizics: Teach Yourself TRIZ, How to Invent, Innovate and Solve “Impossible” Technical Problems Systematically*. TRIZICS.COM, LLC., 2010, ch. 6, pp. 271-274.
- [16] I. Bukhman, “Resources and parameters of resources,” in *TRIZ Technology for Innovation*. Cubic Creativity Company, 20128, ch. 6, pp. 187-210.
- [17] E. Domb. (1998). *Using the Ideal Final Result to Define the Problem to Be Solved* [Online]. Available: <http://www.bmgi.com/research/using-ideal-final-result-define-problem-be-solved>
- [18] N. V. Rubina. (1999). *Methods of Solving Problems Topic 2. Both Cold and Hot (Physical Contradiction)* [Online]. Available: <http://www.osaka-gu.ac.jp/php/nakagawa/TRIZ/eTRIZ/electures/eRubinaCIDBook2-2/GuideBook2-2-2.html> (English translation by Irina Dolina, technical editing by Toru Nakagawa)
- [19] V. Fey and E. Rivin, “ARIZ,” in *Innovation on Demand: New Product Development Using TRIZ*. Cambridge University Press, 2005, ch. 4, pp. 82-109.
- [20] The Welding Experts. *How to Prevent Arc Blow* [Online]. Available: <http://www.lincolnelectric.com/en-us/support/welding-how-to/Pages/preventing-arc-blow-detail.aspx>
- [21] E. Chapman, “Arc welding,” US Patent Application, US1947077 A, Feb. 13, 1934.
- [22] H. E. Schultz, “Arc stray control,” US Patent Application, US2994763 A, Aug. 1, 1961.
- [23] I. Abdurachmanov, “Arc stray controlling welding apparatus,” US Patent Application, US6617547 B1, Sep. 9, 2003.
- [24] J. Holley, “Steel pipe demagnetizing tool,” US Patent Application, US20090072937 A1, Mar. 19, 2009.
- [25] D. Cavallucci, F. Rousselot, and C. Zanni, “Initial situation analysis through problem graph,” *CIRP Journal of Manufacturing Science and Technology*, vol. 2, no. 4, pp. 310-317, 2010.
- [26] D. Cavallucci, F. Rousselot, and C. Zanni, “On contradiction clouds,” *Procedia Engineering*, vol. 9, pp. 368-378, 2011.
- [27] David Meeker. *Magnetic Circuit Derivation of Energy Stored in a Permanent* [Online]. Available: <http://www.femm.info/wiki/PMEnergy>
- [28] Jay Fisher. *Magnetic Property Measurement of Selected Pipeline Steel Specimens* [Online]. Available: <http://www.swri.org/4org/d18/nde/magprop.htm>

