

The importance of a harmonized sprayers inspection: The SPISE manual

JP Douzals¹, V Polveche² and Z. Czaczyk³

¹Irstea, Montpellier, France

²GIPPULVES, Montpellier, France

³Poznan University, Poland

Introduction

Since the publication of EN ISO 16122 part 1 to 4 series in 2015, the framework for the inspection of sprayers is getting harmonized among EU member states. The standard series specifies mandatory requirements in terms of pre inspection (EN ISO 16122-1) and all the inspected items and functionalities of the sprayers (EN ISO 16122-2, 16122-3, 16122-4). The aim of this SPISE manual is to explain the reason for the requirements, to highlight some practical situations and to identify major defaults that can sometimes be observed. The SPISE Advice does not substitute existing standards but completes the EN ISO 16122 series standards in a practical way.

1. Principle of the SPISE Advice

First a brief description of the content of EN ISO 16122 standard series (mainly Part 2 for boom sprayers) is proposed and focuses on:

- (i) elementary components/parts to be inspected,
- (ii) function tests in order to inspect a circuit based on a group of components and ad hoc methodologies
- (iii) checking of the accuracy of measuring device of parameters involved in the determination and the verification of the application rate (gauges pressure, flowrate, forward speed, ...).

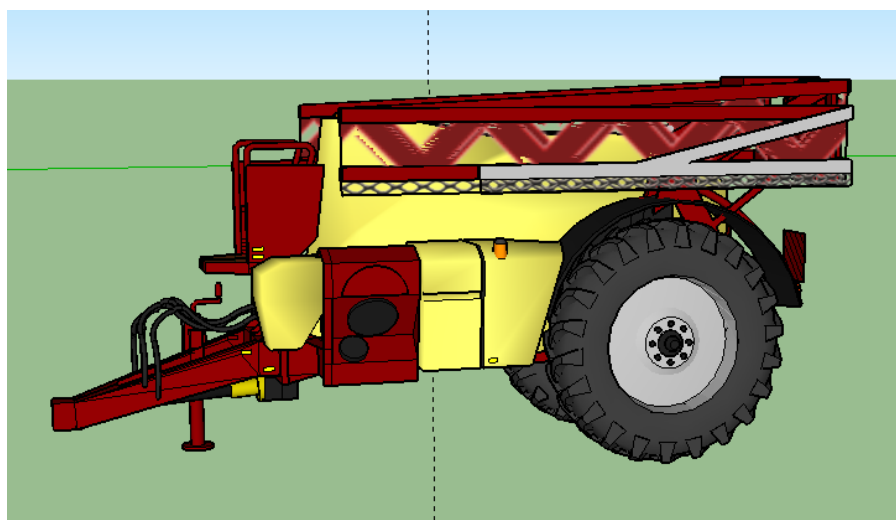

Figure 1: Schematic design of a trailed boom sprayer. Source Sketchup 3D Warehouse – Verkley design and modeling.

Second the SPISE Advice describes the different types of sprayers circuits and how to conduct a proper inspection in practice considering those circuits.

2. Structure and functioning of boom sprayers: what to know for a proper inspection

A boom sprayer is a typical machine used for broadcast spraying on row crops. Its structure is composed of:

- A framework (chassis) supporting all components (tank, pump,..) and moving parts (unfolded/folded and height adjusted booms). In many cases, the transmission allows the physical connection of the pump(s) and fans with the power supply through a PTO shaft.
- A spray mix circuit composed of tank(s), filters, pump(s), pressure valve, hoses and pipes, boom section valves, allowing the management of the spray mix from the main tank to the nozzle through boom sections and nozzle holders. Depending on the technology, the circuit may be more or less sophisticated with none up to 2 flow meters, the presence/absence of compensated returns, etc. Two main parameters are used to manage spray mix circuits: pressure and flow rate with the help of gauges or electronic sensors.
- The functioning of the boom sprayer is getting more complex with additional sensors for forward speed, boom height, GPS, etc. In general, the sprayer owns a control display used to activate/deactivate the sprayer and/or boom sections, set the pressure and read the information of the applied rate, flow rate, ...

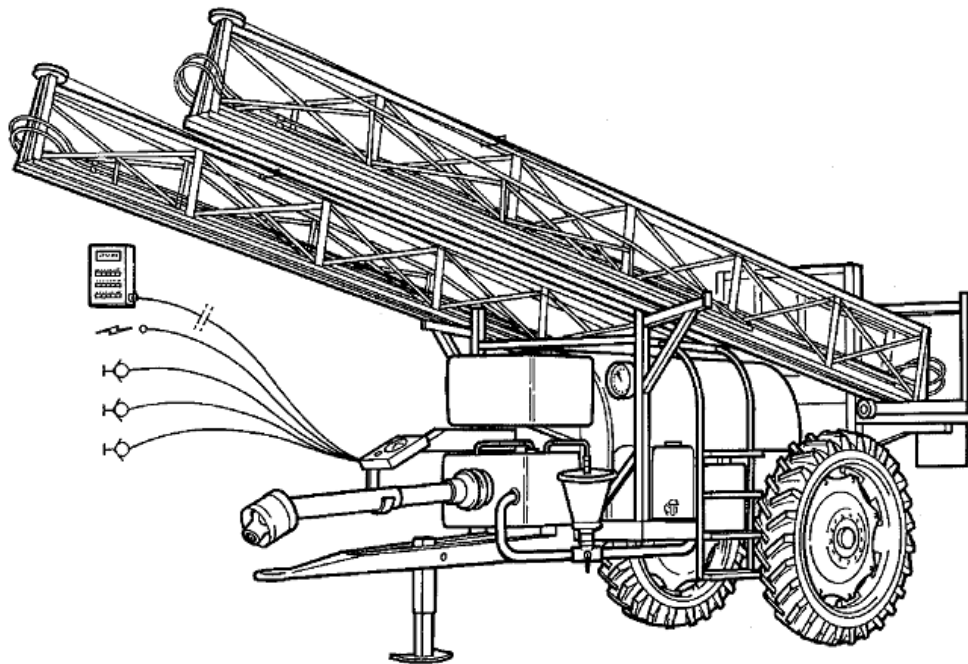

Fig 2 : Design of a trailed boom sprayer. Source: Cemagref.

Critical aspects of the inspection of a boom sprayer

Identification and classification of the sprayer

Boom sprayers can be classified according to three descriptors

(a) spray mix circuit type :

- Regular circulation with or without compensated returns, generally with a flow meter
- Semi-continuous or continuous circulation with or without compensated returns with 1 flow meter
- Regular circulation with 2 manometers...

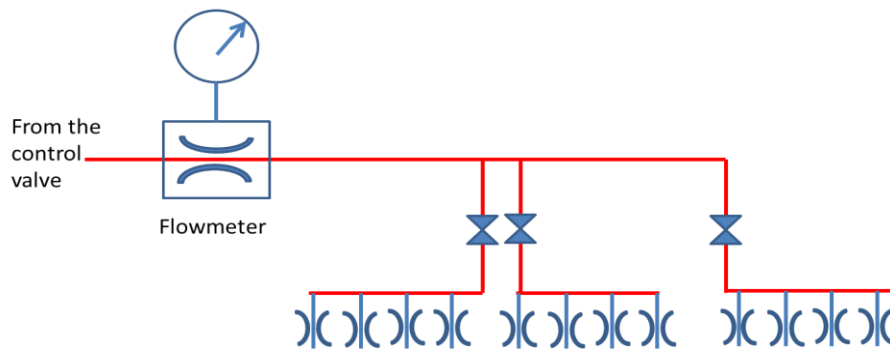

Figure 3 : Ex. boom sprayer with a regular circulation circuit – no compensated returns, 1 flow meter.
Source after GIP Pulves.

(b) The type of control :

- Constant pressure with a simple 3 way pressure valve.
- Flow rate proportional to PTO revolution speed (DPM) using a pressure controller
- Flow rate proportional to forward speed (DPA) using a pilot operated control valve or a flow rate controller. In this case a mechanical or an electronic sensor provides the information of the forward speed (DPAe).

(c) The number of sections:

Hydraulic boom sections are generally different than what the mechanical structure of boom sections would suggest. For boom sprayers with regular/discontinuous circulation, the number of hydraulic sections corresponds to the number of section valves even though T connectors between subsections may be found. In this case a calibrated manometer can be mounted on each section. In the case of continuous circulation, the shut-off of the boom section is not achieved with control valves but by using pneumatic membranes (similar to antidrip systems). Feeding hoses to mount calibrated manometers can be less than the number of sections.

3. The inspection of the sprayer

3.1 Location and test equipment for the inspection

Prior to the inspection itself, the inspection workshop shall verify a number of requirements concerning practical location for a correct inspection:

- Dimensions, meteorological conditions
- Health and Safety of the inspectors (PPE provision)
- waste water management (indoor/outdoor)
- Power source management (tractor, electrical PTO...)
- List of equipment - Mobile truck/van

3.2 Preliminary inspection

EN ISO 16122 part 1 provides guidelines for the safety of the inspector, some mechanical parts can cause dangerous damages like the lack of protection of a PTO Shaft and damaged or absent connectors bowls.

The framework of the sprayer shall be in good shape, with according mechanical resistance. The presence of rust on surface of the chassis is not necessarily a major default. The structure shall not be bended, broken or loose and the sprayer components shall be tightly fixed.

9 pre-inspection items are listed and illustrated in fig 4.

1. Place for inspection
2. Clean sprayer
3. PTO shaft and Power input connectors (PIC), universal joints, locking systems
4. PTO shaft guard
5. Protections of any moving/rotating part
6. Pipes, hoses for hydraulic transmission
7. Structural parts and framework (incl. hitching)
8. Locking of foldable parts
9. Blower (blades, guarding)
10. blower clutch

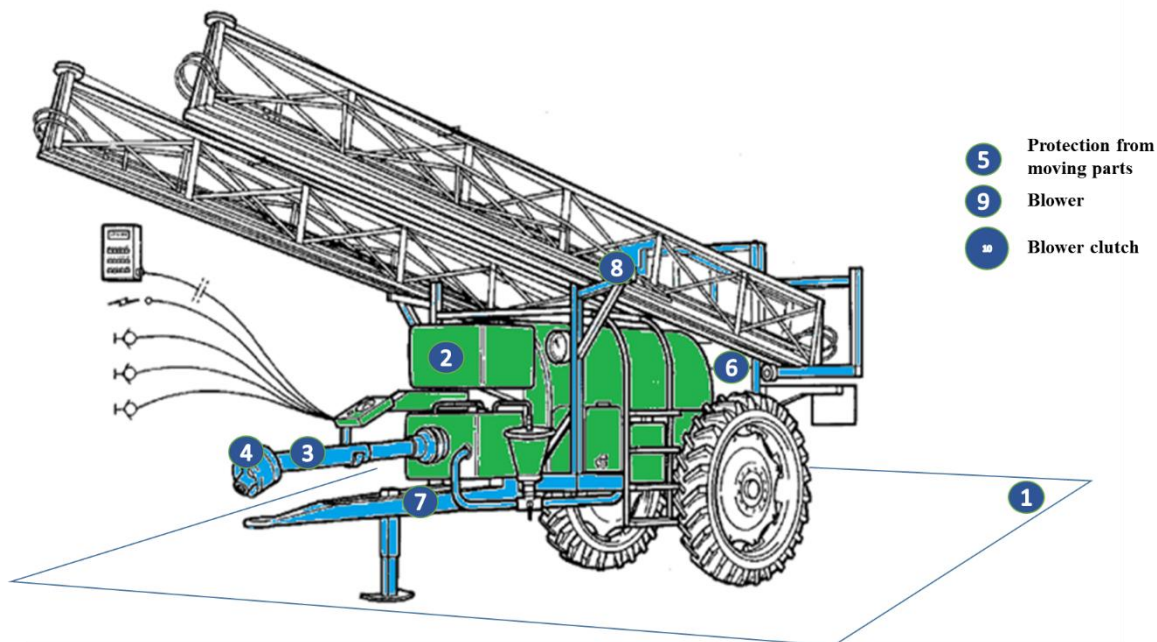

Figure 4: Sprayer shape components to be inspected during preliminary inspection. Source: Cemagref.

3.3 The inspection of sprayer

As mentioned earlier, the sprayer inspection encompasses 3 different stages: the inspection of elementary components from the structure of the sprayer to the hydraulic circuit, the verification of the correct functioning of the sprayer with ad hoc methods and finally the accuracy of all measuring devices needed to set and apply the desired application rate.

3.3.1 Elementary components to be inspected

Altogether, 25 elementary sprayer components have to be inspected regarding their presence, shape and integrity as illustrated by fig 5. Most of a time, a visual check or a simple function test may highlight the main defaults. Additional evaluation of the circuit is done during function tests. All components of the circuit that shall be dismantled (ex. suction and pressure filters) require attention from the inspector due to the risk of contamination.

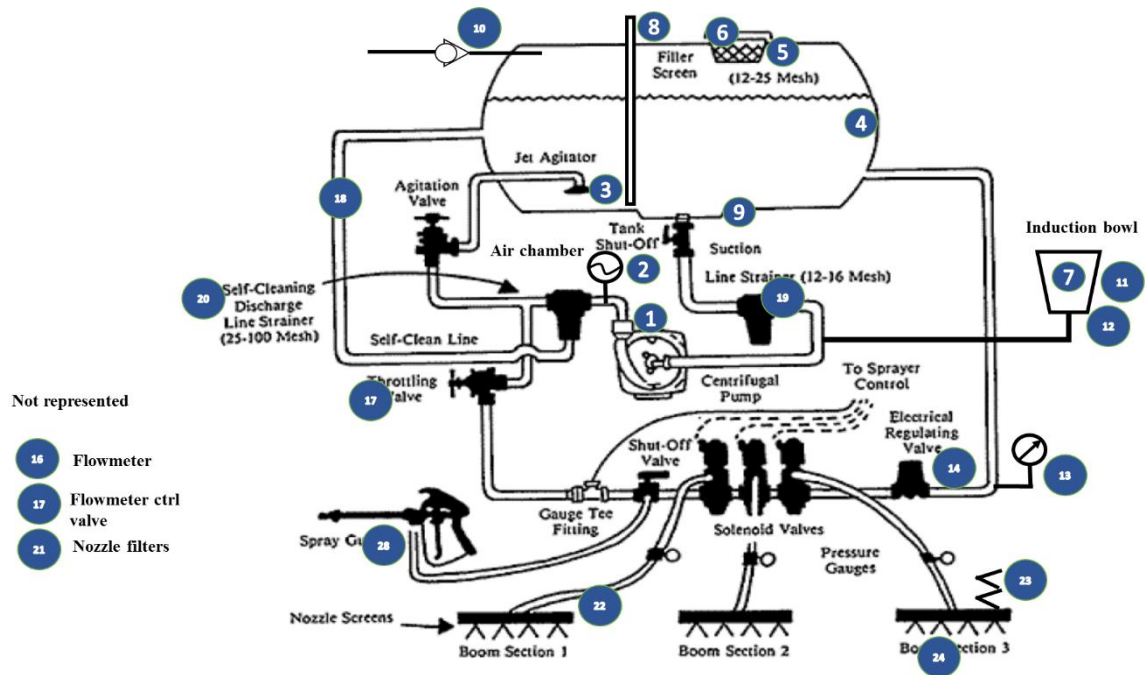

Figure 5 : Sprayer circuit components to be inspected according to EN ISO 16122-2. Circuit from Grisso et al, 1991.

The boom is one of the components that is mostly subjected to damages. Indeed the constrains on the boom are generally high during spraying due to the bouncing with horizontal and vertical forces. Most of the booms are now suspended and the suspension is also checked through a function test.



Figure 6: Boom suspension and horizontal tests. Source GIPPulves
 Along with the boom inspection, the protection of the last nozzle (fig 7) is a mandatory inspection item.

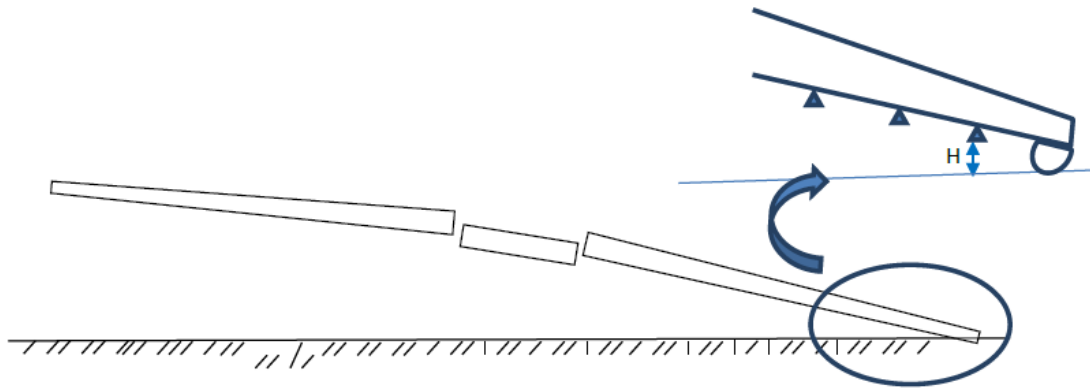

Figure 7: Practical test of the end-of-boom nozzle protection. Source GIPPulves

3.3.2 Function test to check the spray ability

16 specific function tests aim at verifying the correct functioning of the sprayer, the absence of major leaks or dripping, the quality of the agitation and the functioning of main valves (main on/off, boom sections, etc.) As each sprayer might be different from another, the presence of the user may avoid time losses trying to understand the functioning of the sprayer and the sprayer controller.



Figure 8: Boom section test, pressure homogeneity test, pressure drop test. Source GIPPulves

3.3.3 The accuracy of measuring devices to set and apply the application rate.

The main issue that needs measurement is to verify whether the chosen application rate can be set and verified. Altogether 14 methods of verification are proposed. Pressure gauge accuracy and pressure drop between the control valve and the nozzle are checked. All other sensors are also to be checked. A specific point relies on the homogeneity of the lateral distribution that can be checked either by using a distribution patternator (result method and direct verification) or by checking nozzle flow rate and pressure homogeneity along sections (analytical method and not direct verification).



Figure 9: Pressure drop during boom section shut-off/on. Source GIPPulves.



Fig 10: nozzle flowrate & nozzle homogeneity measurement (source GIPPulves)

3.4 The inspection report

Meanwhile to the inspection, an inspection test report is produced and gathers all necessary information on the owner, the inspection workshop and location, the sprayer identification and technical information including measuring results. The report is given to the owner together with a sticker placed on the machine. According to local/national regulations a copy of the test report is sent to the local/national responsible body.

Conclusion

The SPISE advice on sprayer inspection of sprayers, used together with the reference standards, may help to define a more harmonized inspection based on common knowledge, experience and practices from the different EU member countries.

References

- EN ISO 16122 – 1, 2015. Agricultural and forestry machinery -- Inspection of sprayers in use -- Part 1: General
- EN ISO 16122 – 2, 2015. Agricultural and forestry machinery -- Inspection of sprayers in use -- Part 2: Horizontal boom sprayers
- EN ISO 16122 – 3, 2015. Agricultural and forestry machinery -- Inspection of sprayers in use -- Part 3: Bush and tree crop sprayers
- EN ISO 16122 – 4, 2015 Agricultural and forestry machinery -- Inspection of sprayers in use -- Part 4: Fixed and semi-mobile sprayers
- Grisso, Robert D.; Varner, David L.; and Klein, Robert N., "G91-1020 Plumbing Systems of Agricultural Sprayers" (1991). *Historical Materials from University of Nebraska-Lincoln Extension*. 701.
<http://digitalcommons.unl.edu/extensionhist/701>