

3-1975

## In Vivo Quantitation of Adipose Tissue by Differential Absorptiometry Using Penetrating Isotopic Radiation

Luther E. Preuss

Frank B. Bolin

Claudius K. Bugenis

Follow this and additional works at: <https://scholarlycommons.henryford.com/hfhmedjournal>



Part of the [Life Sciences Commons](#), [Medical Specialties Commons](#), and the [Public Health Commons](#)

---

### Recommended Citation

Preuss, Luther E.; Bolin, Frank B.; and Bugenis, Claudius K. (1975) "In Vivo Quantitation of Adipose Tissue by Differential Absorptiometry Using Penetrating Isotopic Radiation," *Henry Ford Hospital Medical Journal* : Vol. 23 : No. 1 , 33-42.  
Available at: <https://scholarlycommons.henryford.com/hfhmedjournal/vol23/iss1/7>

This Article is brought to you for free and open access by Henry Ford Health System Scholarly Commons. It has been accepted for inclusion in Henry Ford Hospital Medical Journal by an authorized editor of Henry Ford Health System Scholarly Commons.

## In Vivo Quantitation of Adipose Tissue by Differential Absorptiometry Using Penetrating Isotopic Radiation

Luther E. Preuss,\*  
Frank P. Bolin,\*  
Claudius K. Bugenis\*

*The physical principles for determining tissue lipid content in vivo by selective radiation attenuation have been studied and are compared to other methods of body composition analysis. Two penetrating photon beams, each monoenergetic but of differing energies, are simultaneously passed through the low Z components of tissue and the relative beam absorption measured. A mathematical function incorporating the unabsorbed and absorbed photon beam intensities is applied to determine experimentally the relative proportion of fat and lean in the tissue. <sup>109</sup>Cd is used as the radioactive source of both x-rays and gamma radiation. Results of experiments on low Z phantom material and in vitro animal tissue indicate that the dual photon absorption principle provides accurate two-component quantitation. The fractional lipid content of in vitro mammalian tissue samples has been determined by dual beam photon absorption, with an error of less than 2%. In vivo values are reproducible to better than 2%. Skinfold thickness was measured simultaneously in vivo with adipose tissue content by dual beam absorptiometry. The experimental coefficient of correlation between these two measurements was .98.*

---

\* Department of Physics & Biophysics, Edsel B. Ford Institute for Medical Research

Address reprint requests to Mr. Preuss at EBF1, Henry Ford Hospital, 2799 West Grand Boulevard, Detroit MI 48202

The problem of measuring human body composition is an intriguing one and has occupied investigators for several decades. Such a measurement for the in vivo state is especially challenging. Much of such composition study in the past has centered on the determination of bone mineral, lean body and adipose mass. The importance of accurate assay of soft tissue qualities is obvious.

A number of systems have been tried for adipose tissue assay. Clearly, the most rigorous analytical method is the direct chemical analysis of the soft tissue.<sup>1</sup> Excellent accuracy is obtained in this manner, but the procedure is painstaking. The method, as with all sampling systems, is obviously inapplicable to living subjects, but it is in the in vivo state that these measurements are the most useful. A simple procedure is the mechanical measurement of skinfold thickness for the quantitation of subcutaneous fat.<sup>2</sup> This method is useful when applying it to large populations of subjects, as in statistical studies, but it does not measure intra-muscular fat, is highly susceptible to operator fallibilities, and the precise relation of skinfold measurements to total body fat is not fully equated. Another analytical approach is the determination of the specific gravity of the human body by underwater weighing.<sup>3</sup> A value of relative leanness or obesity may be obtained by this

principle, if certain assumptions about the weight of bone and proportion of lean body mass are accepted. However, these assumptions are not solidly grounded. In addition, underwater weighing is impractical for use with bedridden subjects and others and is, in any case, clearly inconvenient and technically difficult, requiring a measurement of lung volume and estimates of the volume of abdominal viscera. Placing the subject in a nitrogen-rich atmosphere and measuring the uptake of the gas<sup>4</sup> (which dissolves more readily in lipid than in other tissues) can provide a measure of fat content, but the system is tedious and numerous uncertainties are involved.

A relatively recent field is composition analysis through neutron activation analysis (NAA).<sup>5</sup> The *in vivo* use of NAA on humans, however, is still in the experimental state and is being applied principally to bone density rather than soft tissue. One of the reasons for caution in this analytical system is that there exists the possibility of inducing very significant radiation dosage levels. Another method assays the natural body radioactivity from <sup>40</sup>K.<sup>6</sup> From this information one may arrive at a measure of the total body potassium and an estimate of the lean body mass. The assumption here is that most body potassium is concentrated in the lean tissue cells, but there are divergent views on this subject and further investigation of this principle is required.<sup>7</sup> Some difficulties of these latter two approaches are the correction of the data for subject geometry and the internal absorption of radiation in the body.

### Photon Absorptiometry

The particular principle of body composition analysis that has concerned our laboratory involves the absorption of penetrating radioisotopic radiation in tissue.<sup>8,9</sup> We have been principally interested in the *in vivo* determination of tissue lipid content. Through the small but differing absorption properties for x-rays and low energy gamma rays in adipose and lean tissue, one may

determine the relative proportions of these two major tissue components by passing two photons of known and unique energies through the same path of tissue sample and observing the resultant attenuation.<sup>10,11</sup> If the atomic constituents of the two components are known, the relative attenuation of the two beams may be predicted for the full range from 100% protein to 100% lipid. Thus, experiment (*in vitro*) may be checked with theoretical prediction. We have utilized the 22 keV and the 88 keV radiations from the radionuclide <sup>109</sup>Cd for the determination of fat-lean ratios of both *in vitro* and *in vivo* tissue samples. Theoretically, a third radiation might be added to allow for the additional inclusion of a bone mineral density determination. The number of radiations required will equal the number of variables for which solutions are sought. If the variables are lean, fat, and bone density, three monochromatic beams will be required. For four variables, four beams are required and so on. Certain severe statistical problems intrude in the manipulations when more than two variables are assayed in this manner.

### Theory

The exponential absorption of gamma and X radiation is described by the equation  $I = I_0 e^{-\mu \rho x}$  where  $I_0$  is the incident intensity of the x-ray beam,  $I$  is the transmitted intensity,  $\mu$  is the mass absorption coefficient\*,  $\rho$  is the density, and  $x$  is the thickness of the sample through which the beam passes.  $\mu$ , for any complex substance, is the weighted average of the mass absorption coefficients of the individual elements comprising the sample.

For two monochromatic beams of different energies and with incident photon in-

\*  $\mu$  is an indicator of the average absorptive capacity per atom of substance; the greater the value of  $\mu$ , the more the incident beam is absorbed. In addition,  $\mu$  generally decreases with increasing incident beam energy (with some predictable exceptions).

## Quantitation of Adipose Tissue by Differential Absorptiometry

tensities  $I_{01}$  and  $I_{02}$ , passing through the same sample, one may write the following simple expressions:

$$I_1 = I_{01}e^{-\mu_1 \rho X} \quad (1)$$

$$I_2 = I_{02}e^{-\mu_2 \rho X} \quad (2)$$

The  $\mu$ 's differ because of the different energies of the two beams.

From equations (1) and (2) we obtain the ratios:

$$I_{01}/I_1 = e^{\mu_1 \rho X} \quad (3)$$

$$I_{02}/I_2 = e^{\mu_2 \rho X} \quad (4)$$

Taking logarithms of the ratios in (3) and (4),

$$\ln(I_{01}/I_1) = \mu_1 \rho X \quad (5)$$

$$\ln(I_{02}/I_2) = \mu_2 \rho X \quad (6)$$

Division of equation (5) by equation (6) results in a key quantity, arbitrarily termed  $R$ .<sup>12</sup>

$$R = \frac{\ln(I_{01}/I_1)}{\ln(I_{02}/I_2)} = \frac{\mu_1}{\mu_2} \quad (7)$$

For the single complex sample, traversed by the dual energy beam, density ( $\rho$ ) and absorber thickness ( $X$ ) fall out of the expression since they are identical for both beams (as would be the case for tissue in a dual beam system). The value of  $R$  is, thus, characteristic of the absorber quality and is photon energy dependent;  $R$  is independent of the thickness of the absorber. Note that for any dual combination,  $R$  is theoretically predictable (from  $\mu_1/\mu_2$ ) using the weighted mass absorption coefficients.  $R$  is also experimentally determinable from the beam intensity portion of expression (7).

If an absorber, such as tissue, consists of two substances, a and b, whose fractional proportions are  $F_a$  and  $F_b$ , then the following can be shown to hold,<sup>12</sup>

$$F_a = \frac{R - R_b}{R_a - R_b} \quad (8)$$

or

$$\% F_a = \frac{R - R_b}{R_a - R_b} \times 100 \quad (9)$$

where  $R_a$  and  $R_b$  are the  $R$  values of the pure components a and b

This is applied in the following fashion. Supposing that soft tissue is arbitrarily assumed composed of the two components, fat\* and fat-free tissue (FFT)\*\*, then from equation (9) one may write

$$\% \text{ lipid} = \frac{R_{\text{tissue}} - R_{\text{FFT}}}{R_f - R_{\text{FFT}}} \times 100 \quad (10)$$

where  $R_f$  is the value for 100% lipid and  $R_{\text{FFT}}$  is the value for 100% fat-free tissue. The theoretically predicted values of  $R_f$  and  $R_{\text{FFT}}$  are 2.31 and 3.71 respectively for the 22 keV and 88 keV radiations from <sup>109</sup>Cd.<sup>9</sup> Hence, from (10)

$$\% \text{ lipid} = \frac{3.71 - R_{\text{tissue}}}{1.40} \times 100 \quad (11)$$

\* For the purpose of this paper, the terms 'lipid' and 'fat' may be used interchangeably. However, fat or lipid herein does not refer to the very small fraction of cellular phospholipid which is not ether extractable.

\*\* The term "fat-free tissue" will be used herein in preference to the term "lean" to describe that elemental tissue complex exclusive of stored extractable lipids. It will be abbreviated to FFT.



Thus, with R determined from beam intensities for any complex sample, the fraction of tissue lipid may be obtained from this simple linear relation.

Figure 1 is a graph of equation (11) showing the percentage of fat as a linear function of the R value (for the  $^{109}\text{Cd}$  source).

Experimentally, the R value of tissue is determined by means of equation (7) from the beam intensity values of  $I_{01}$ ,  $I_1$ ,  $I_{02}$  and  $I_2$  which may be obtained in a straightforward manner.

The validity of this determination is dependent on correctly dividing the components (fat and FFT) of the sample into their constituent elements. For this work, the following is considered to be representative of the composition of the stored lipid of adipose tissue: 77% carbon, 11.5% oxygen, 11.5% hydrogen.<sup>13</sup>

The composition of FFT that we have assumed is shown in Table 1. Note from the table that the higher Z trace elements, though present only in small amounts, contribute significantly to photon beam attenuation because of their larger mass absorption coefficients and correspondingly greater absorptive quality.

#### Experimental System, Source and Procedure

The electronic arrangement that is employed is shown in block diagram in Figure 2. A linear amplifier has since been added between the preamp and timer. The multi-channel analyzer is utilized principally to monitor electronic drift in the overall gain of the system and to observe the spectral quality of the x-ray beams. The simultaneous emission of the two photons from the  $^{109}\text{Cd}$  requires the parallel energy analysis of the NaI detector output for the 22 and 88 keV photons. This is accomplished by means of high quality single channel analyzers, each set to pick off the appropriate detector voltage pulse. A "ramp" correction must be made on the 22 keV beam intensity

to adjust for the Compton continuum produced in the NaI detector from the higher energy 88 keV beam, since detection of the two energies must be simultaneous.<sup>10</sup>

From several candidates for the radioisotopic photon source, we have chosen  $^{109}\text{Cd}$ . This specific radionuclide is convenient for a number of reasons. First, its half life is sufficiently long (453 days) to allow a single source to be used for more than two years before replacement is required. Second, there is the advantage of having a single simultaneous source for both radiations. This eliminates problems of geometry and timing inherent in a double source. Third, filtering with metallic Pd makes possible an acceptable level of monochromaticity of the 22 keV radiation through elimination of the  $K_{\beta}$  x-ray component.

$^{109}\text{Cd}$  decays by electron capture to  $^{109}\text{Ag}$ ; the transition is to the 87.7 keV excited state of  $^{109}\text{Ag}$ . The resultant photons of interest are the 87.7 keV gamma ray and the characteristic K and L shell silver x-rays. The characteristic x-rays of interest occur principally as four radiations  $K_{\alpha 1}$ ,  $K_{\alpha 2}$ ,  $K_{\beta 1}$ ,  $K_{\beta 2}$ . These radiations have energies of 22.162 keV, 21.988 keV, 24.942 keV and 25.454 keV respectively. The mass absorption coefficients of the  $K_{\alpha 1}$  and  $K_{\alpha 2}$  photons are sufficiently close, one to the other, so as to enable one to ignore the difference and consider them as a photon of single energy. On the other hand, the mass absorption coefficients for the  $K_{\beta 1}$  and  $K_{\beta 2}$  x-rays differ from the  $K_{\alpha}$  photons to a degree that introduces a significant error due to the polychromaticity effect. For this reason, it is desirable to reduce the intensities of the  $K_{\beta 1}$  and  $K_{\beta 2}$  radiations. To accomplish this end, a 0.1 mm Pd foil filter is applied to the beam. This attenuates the  $K_{\beta 1}$  and  $K_{\beta 2}$  beams by a factor of 770, while the 22 keV  $K_{\alpha}$  beam is decreased by a factor of 4. The result is that the  $K_{\alpha}$  22 keV silver x-rays make up 99.9% of the characteristic photons. (The Pd filter attenuates the 87.7 keV beam by only 20%.)

## Quantitation of Adipose Tissue by Differential Absorptiometry

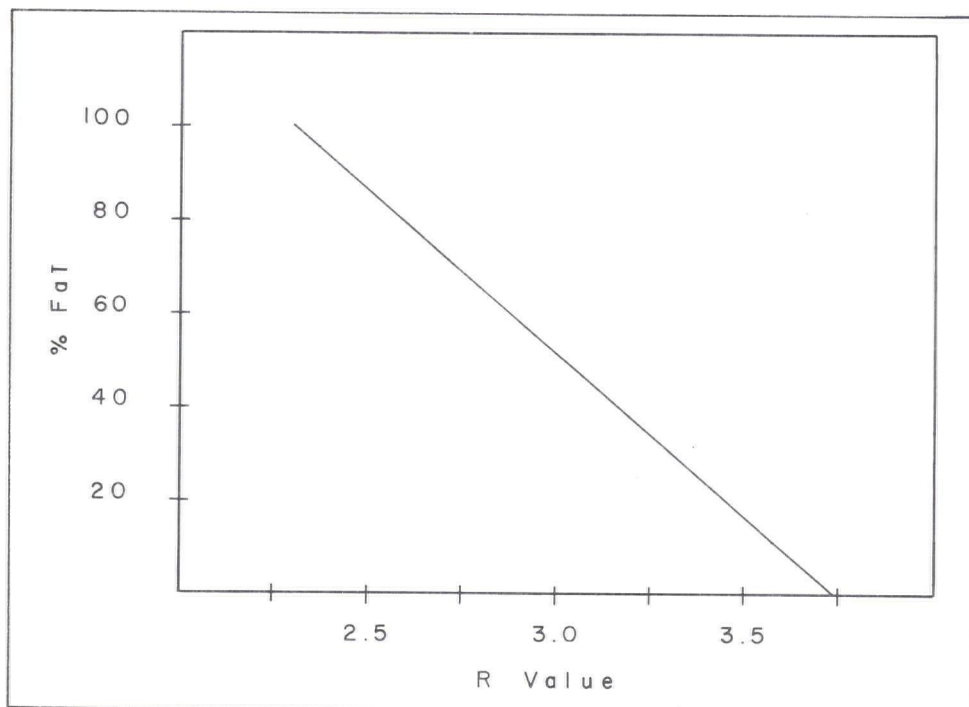

Figure 1:

Linear relationship between R value of tissue and percent fat. Such a standard plot may be used to convert experimentally obtained R values to values of percentage fat. This plot is specific only for dual beam absorptiometry when using the two radiations (22 and 88 keV) from radioactive  $^{109}\text{Cd}$ . Dual beam sources with other photon energies will show standard curves with differing slope and end point.  $^{109}\text{Cd}$  is the isotopic source of choice since it has the broadest spread between end points.

**TABLE I**  
**COMPOSITION OF FAT-FREE TISSUE**  
**(and associated coefficients for  $^{109}\text{Cd}$  radiation)**

ELEMENT	% WEIGHT	$\mu_{22}$	$\mu_{88}$
O	77.4	.670	.162
H	10.0	.366	.301
C	9.03	.368	.157
N	2.69	.475	.158
K	.31	8.10	.279
S	.24	4.85	.232
P	.19	4.00	.209
Cl	.08	5.95	.256
Na	.08	1.68	.173
Mg	.02	2.05	.183

Composition of fat-free tissue,<sup>4,7</sup> as defined in these experiments. Theoretical predictions, for dual beam absorptiometry, based on these ratios, show good correspondence with experiment.

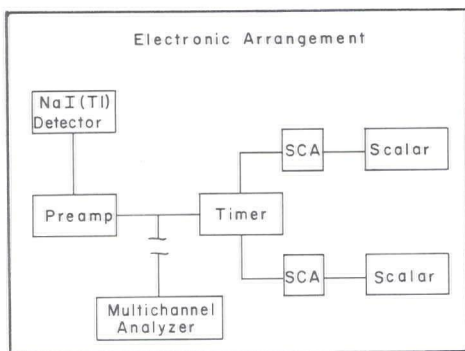

Figure 2:

Block diagram of detection equipment and the associated electronic system used for analysis of soft tissue. SCA represents 'single channel analyzer'. Readouts, manual and automated, but not shown, were used for beam intensity data collection.

To fabricate the dual beam research source, the cadmium isotope is sealed within the lucite cylinder which in turn is mounted inside of a small block of shielding and collimating tungsten alloy. A circular aperture, 3.8 mm in diameter, in one end of the block allows a conical, 0.002 steradian beam of radiation to escape. Together with the detector housing, the source is rigidly fixed to a metal base. The base is mechanically linked to a motor and worm gear in such a way as to allow the photon beam to scan across the tissue sample being analyzed.<sup>12</sup> This is especially desirable when doing in vivo work, since the effect of local inhomogeneities may be averaged out.

Once aligned, the system is simple in operation. In vitro tissue samples may be placed in hollow lucite cylinders whose ends are sealed with saran. After being sealed, the cylinder is exposed to the source for approximately 5 to 10 minutes. The intensity of the radiation in the attenuated beam is recorded by the scalars and these intensity values are used to calculate the R value, or the percent fat of the sample by means of equations (7) and (9). The manipulations are carried out by a simple computer program.

For in vivo work, a special immobilizing device is used which holds a human limb stationary while the source scans across the chosen area.<sup>15</sup> The current scanning system has a maximum traverse of about 12.7 cm. The source strength (5 to 15 mCi) allows an analysis of tissue having a thickness of 1 to 9 cm. Radiation dosage is small. For example, a five-minute fixed-point exposure of the triceps muscle delivers a dosage of less than 1 mrad which is limited to beam dimensions (about 3 cm<sup>3</sup> of arm tissue). Scanning reduces the dosage substantially, since a large tissue volume receives the same total energy deposition.

### Experimental Results (Mammalian Tissue and Simulators)

A series of experiments was carried out to ascertain whether the <sup>109</sup>Cd dual beam absorptiometric principle could accurately de-

TABLE II  
THEORETICAL vs EXPERIMENTAL R VALUES FOR PHANTOMS

SAMPLE	EXPERIMENTAL R VALUE	THEORETICAL R VALUE	DIFFERENCE	% DIFFERENCE
Polyethylene	2.063	2.063	0.000	0.0%
Sugar	3.096	3.101	-0.005	0.2%
Water	3.607	3.590	+0.017	0.5%
Teflon	4.768	4.805	-0.037	0.8%

The theoretical and experimental R values using <sup>109</sup>Cd photons for various phantoms are compared. Correspondence is good. Theoretical values were obtained from equation (7). The phantoms' R values bracket the predicted R values for adipose and lean tissue, thus proving the range of the <sup>109</sup>Cd dual beam system.



## Quantitation of Adipose Tissue by Differential Absorptiometry

termine theoretical R values. A group of substances (selected for an R value range related to tissue) was prepared for examination, and theoretical R values were computed using currently published absorption coefficient tables. The  $^{109}\text{Cd}$  dual beam was impinged upon each sample to obtain an experimental R value. Table II compares these two sets of values. A second series of experiments was performed similarly on a group of lipid substances. The theoretical R value for human lipid is predicted to be 2.308. Table III shows that the experimental R values of five lipid types agree remarkably well with the figure predicted for human lipid. It is interesting to note from Table III that the R values are substantially the same regardless of whether the lipid sample was of animal or vegetable origin, liquid or solid.

The encouraging results shown in Tables II and III lend credence to the theoretical basis of the work and were an important feature of our initial experimentation.

In vitro studies on animal tissues were carried out to establish how accurately the experimental determination of lipid content of a two-component system correlated with a determination by chemical analysis. Lean and fat beef tissues were mixed and homogenized in various proportions by laboratory blender and, subsequent to lipid determination by differential absorption, an ether extraction of the lipid was made. Table IV

**TABLE III**  
**EXPERIMENTAL R VALUES OF LIPID**

FAT	R $\pm$ 0.01
Cod Liver Oil	2.30
Corn Oil	2.31
Olive Oil	2.30
Rendered Lard	2.31
Beef Fat	2.30

**Absorptiometric measurements with  $^{109}\text{Cd}$  on various lipid samples give R values which are in close correspondence.<sup>15</sup> Theoretical R value for lipid is 2.308.**

compares the lipid content found by absorptiometric and chemical analysis. All R values were averages of at least four different determinations; the values for the chemical analysis are averages of results from three ether extractions. Table IV presents good correspondence, given the many uncertainties involved (such as lack of complete information on the elemental composition of lean tissue<sup>7</sup> or inhomogeneities in the sample).

For any one given sample, individual measurements of the fat fraction differed from the average by no more than 0.01. The good results of the dual beam technique with beef tissue suggests that in vivo measurements on living tissue will be highly reliable at the site of measurement.

### **In Vivo** **Human Tissue Assay**

Our initial in vivo work has been carried out on a small number of volunteers. These first fat-lean determinations have utilized the human triceps muscle of the left arm. To bypass difficulties due to local inhomogeneities, the system has been motorized in such a way as to allow it to scan across the area of interest.

The scanning on the upper arm has been done in two perpendicular directions. The first direction is longitudinal, ie, parallel to the bone of the arm. Table V shows the results from five subjects. The arm of the subject was fixed in place and a point on the triceps muscle was selected and marked with a pen. Four separate scans were done, each 2 cm in length, with the midpoint being the marked spot. R values were calculated and the mean arrived at. As shown on Table V the reproducibility of the R value was good, the coefficient of variation being less than 2% in all cases.

There are a number of difficulties presented by longitudinal scanning, however. The most important problem is caused by



the makeup of the arm. Because of the approximately cylindrical symmetry of the bone-muscle-fat layer system, the relative proportion of muscle and fat in a longitudinal section of the arm depends on the distance from the bone. As a result, the longitudinal measurement does not accurately reflect the total fat-lean makeup of the arm. In addition, there are difficulties with repositioning, since small changes in the distance from the bone may cause large changes in the fat-lean ratio.<sup>15</sup>

To elucidate these problems we have also initiated scanning in a transverse fashion, ie, perpendicular to the longitudinal scan and across the bone. Data is taken at dis-

crete points along the scan path. Mathematical and graphical manipulation of the data results in the fat-lean ratio of the entire cylindrical section scanned by the transverse motion.<sup>15</sup> This will presumably better reflect the true upper arm composition. Table VI presents some volunteer data using the transverse scan method. Coincidental with the scan data, skinfold thickness measurements were taken. There is a good ( $\gamma = 0.98$ ) correlation between the percent fat and the skinfold measurements. This is to be expected if the absorptiometric method is providing valid measurements. Other studies by this laboratory will include further scrutiny of the transverse scan procedure.

**TABLE IV**  
**ABSORPTIOMETRIC ANALYSIS OF MUSCLE COMPOSITION**

SAMPLE	R VALUE	FAT FRACTION FROM R	FAT FRACTION BY EXTRACTION	DIFFERENCE	% DIFFERENCE
1	3.40	.225	.224	.001	0.4%
2	3.25	.338	.332	.006	1.8%
3	3.10	.443	.448	.005	1.1%
4	2.64	.764	.762	.002	0.26%
5	2.30	1.005	1.000	.005	0.5%

Percentages of fat of several bovine tissue samples determined by chemical<sup>16</sup> and absorptiometric analyses.

**TABLE V**  
**PERCENTAGE FAT BY LONGITUDINAL SCANNING**

SUBJECT	MEAN R VALUE	% FAT	STANDARD DEVIATION	COEFFICIENT OF VARIATION (%)
1	3.62	6.6	.036	1.0
2	3.51	14.9	.039	1.1
3	3.36	25.7	.064	1.9
4	3.38	23.6	.027	0.8
5	3.35	26.0	.050	1.5

Results of longitudinal scans in the triceps muscles for a fat range of 6% to 26% for five volunteers are shown. The standard deviation and coefficient of variation are computed with respect to the R value.

## Quantitation of Adipose Tissue by Differential Absorptiometry

TABLE VI  
% FAT BY TRANSVERSE SCAN COMPARED WITH SKINFOLD THICKNESS

SUBJECT	R VALUE	% FAT	SKINFOLD (mm)
1	3.48	16.6	6.8
2	3.38	25.6	8.4
3	3.28	30.8	14.3
4	2.87	60.0	23.5
5	2.92	56.5	25.1

Percent fat in the triceps muscle of five volunteers as determined by transverse scanning is compared with skinfold thickness measurements in the same area. The coefficient of correlation is .98.

### Summary

The combination of accuracy, speed, and convenience makes the  $^{109}\text{Cd}$  dual beam absorptiometric analysis system an interesting possibility for the in vivo study of fat-lean ratios in the human body. The very low radiation dosage makes it safe for clinical standardization and allows it to be used repeatedly on individual subjects during experimental trials. The accuracy possible with this method promises to be useful in resolving some of the more difficult dilemmas in the study of body composition. In addition, the possibility of utilizing a third radiation for the measurement of bone mineralization, as a third variable, opens the door to a number of interesting and valuable applications.

The dual beam principle is simple and involves a relatively small electronic instrumentation package, as compared to some of the systems used for compositional analysis. Possibilities for application are numerous. For instance, specific fat-lean ratios might be found to be related to the progression of

body wasting,<sup>17</sup> or the effectiveness of diets.<sup>18</sup> In addition, the fat-lean ratio and its change may be an indicator of the general wellbeing of a patient. Changes in the normal ratio could possibly be an indicator of the onset of pathological conditions.

The absorptiometric method, as with the skin caliper approach, measures the fat ratio only at a given point and it still remains to be seen what true relationship this has to the whole body stored lipid content. However, in contrast to the skin pinch, the absorptiometric principle may be automated and the calculations programmed for a small computer. Additionally, an area of tissue (for instance, the entire upper arm) may be scanned on a point-by-point basis and the average lipid fraction calculated for this body segment. Further studies on volunteers are called for to investigate correlations between anthropomorphic measurements and fat ratios in normal and disease states.

### REFERENCES

1. Forbes RM, Cooper AR, and Mitchell HH: The composition of the adult human body as determined by chemical analysis. *J Biol Chem* **203**:359, 1953
2. Seltzer CC, Goldman RT, Mayer JM: The triceps skinfold as a predictive measure of body density and body fat in obese adolescent girls. *Pediatrics* **36**: 212-18, Aug 1965
3. Behnke AR, Feen BG, and Welham WC: The specific gravity of healthy men. *JAMA* **118**: 495-501 Feb 1942
4. Behnke AR: Physiologic studies pertaining to deep sea diving and aviation, especially in relation to the fat content and composition of the body. *Harvey Lect* **37**:198-226, 1941-42

## Preuss, Bolin and Bugenis

5. Biggin HC, and Morgan WD: Fast neutron activation analysis of major body elements. *J Nuc Med* **12**: 808-14, Dec 1971
6. Cohn SH, and Dombrowski CS: Absolute measurement of wholebody potassium by gamma-ray spectrometry. *J Nuc Med* **11**: 239-246, June 1970
7. Tipton IH: Stable element metabolism. *Health Physics Division Annual Progress Report*, ORNL 4446:330-303, July 1969
8. Mazess RB, Cameron JR, and Sorenson JA: Body composition by absorption of monoenergetic radiation. *AEC Report No. COO-1422-55*, 1969
9. Preuss LE, and Schmonsees WG:  $^{109}\text{Cd}$  for compositional analysis of soft tissue. *Int J Appl Radiation and Isotopes* **23**:9-12, 1972
10. Preuss LE, and Schmonsees WG: The potential use of  $^{109}\text{Cd}$  for dual absorption measurements of soft tissues. *Applications of Low Energy X and Gamma Rays*, New York, Gordon & Breach, 1971, pp 281-289
11. Preuss LE, and Schmonsees WG: Two photon absorptiometric analysis using  $^{109}\text{Cd}$ . *Proceedings of Bone Measurement Conference. USAEC (TID-4500) CONF-700515*, 1970
12. Preuss LE, Bolin FP: *In vivo* tissue analysis with  $^{109}\text{Cd}$ . *Isotopes and Radiation Technology* **9**:501-509, 1972
13. Omnell KA: Quantitative roentgenologic studies in changes in mineral content of bone *in vivo*. *ACTA Radiological Suppl* **148**, 1957
14. Lederer CM, Hollander JM, and Perlman I: *Table of Isotopes*, ed 6, New York, John Wiley & Sons, Inc, 1968
15. Preuss LE, and Bolin FP: *In vivo* analysis of lipid-protein ratios in human muscle by differential x-ray absorption using  $^{109}\text{Cd}$  photons. *Advances in X-Ray Analysis* vol 16, New York, Plenum, 1972
16. Association of Official Agricultural Chemists; *Official Methods of Analysis*, ed 10. Washington, DC, 1965, p 346
17. Craig AB Jr, and Waterhouse C: Body-composition changes in patients with advanced cancer. *Cancer* **10**: 1106-09, Nov 1967
18. Benoit FL, Martin RL, and Watten RH: Changes in body composition during weight reduction in obesity. *Ann Intern Med* **63**: 604-12, Oct 1965