

raf

MAK 00351.



0000098200

Hardware-in-the-loop simulation for automatic rack and pinion steering system / Mohd Zakaria Mohammad Nasir .. [et al.].

HARDWARE-IN-THE-LOOP SIMULATION FOR AUTOMATIC RACK AND PINION STEERING SYSTEM

**MOHD ZAKARIA BIN MOHAMMAD NASIR
ABDUL RAHMAN DWIJOTOMO
MOHD AZMAN ABDULLAH
KHISBULLAH HUDHA**

UNIVERSITI TEKNIKAL MALAYSIA MELAKA

Hardware-in-the-loop Simulation for automatic rack and pinion steering system

Mohd Zakaria Mohammad Nasir^{1, a}, Abdulrahman Dwijotomo^{2, b}, Mohd Azman Abdullah^{3, c} Muhammad Zahir Hassan^{4, d} and Khisbullah Hudha^{5, e}

^{1, 2, 3, 4, 5} Faculty of Mechanical Engineering,
Universiti Teknikal Malaysia Melaka,
Hang Tuah Jaya, Durian Tunggal,
76100 Melaka, Malaysia

^amzakaria@utem.edu.my, ^barjay.mix88@gmail.com, ^cmohdazman@utem.edu.my,

^dzahir@utem.edu.my, ^ekhisbullah@utem.edu.my

Keywords: rack and pinion, automatic steering system, HILS

Abstract. Vehicle handling behaviour is much influenced by the performance of steering system and its mechanism. In this paper, a Hardware-in-the-loop Simulations (HILS) test rig has been set up with Matlab XPC TARGET environment, LVDT and rotary encoder sensors installed onto actual rack and pinion steering mechanism, for data measurement at various steering angle. It can manipulate the steering mechanism with various control structure, decrease time with real experiment and trial risk as well as improve development efficiency. Results from experimental model demonstrate a linear pattern occurred from maximum lock-to-lock steering wheel angle and it is closely follow the sine input trend through HILS experiment with acceptable error.

Introduction

Automatic steering system is merging into vehicle model more focuses on lateral control which concerned with lane keeping, lane changing and turning [1]. It involves the driver looking ahead at the intended path relative to the car and somehow processing the preview information and the current position data to yield the steering wheel or control inputs needed to make the car follow the desired path. Steering linkages play a very importance role in manoeuvring of a vehicle. Amongst the steering linkages, the rack and pinion steering linkage is the most popular and widely used in automotive passenger vehicle [2-5]. This linkage consists of two steering arms (wheel knuckle), two tie rods end as well as a rack and pinion. In future automatic steering system, the electric power steering is a vital component for control and improving vehicle handling and stability [6, 7]. A traditional method required long time and yet spend plenty of trial expenditure to test the new algorithm especially in steering system. Moreover the real test is extremely dangerous for test in vehicle under high speed condition. Therefore, it can be useful as a development tool since it more repeatable and cost effective than a full in-vehicle test [8, 9].

Hardware-in-the-loop- Simulation (HILS) test setup

A typical Hardware-in-the-loop simulation (HILS) system designed consist simulation and analysis platform (Host pc), man-machine interface (Target pc), controller and real time sensors. Fig. 1 a) shows the HILS structure developed for automatic steering system.

The relationship between rotation of pinion and displacement of rack can be defined by perform an experimental on actual rack and pinion steering system through HILS. The front tire is set in normal position, and Linear Variable Differential Transformer (LVDT) sensors used for calibration. The angular sensor collect the real time angle of the steering wheel .As a driving device, the DC motor as an actuator to generate desired steering wheel angle turn left or right respectively.

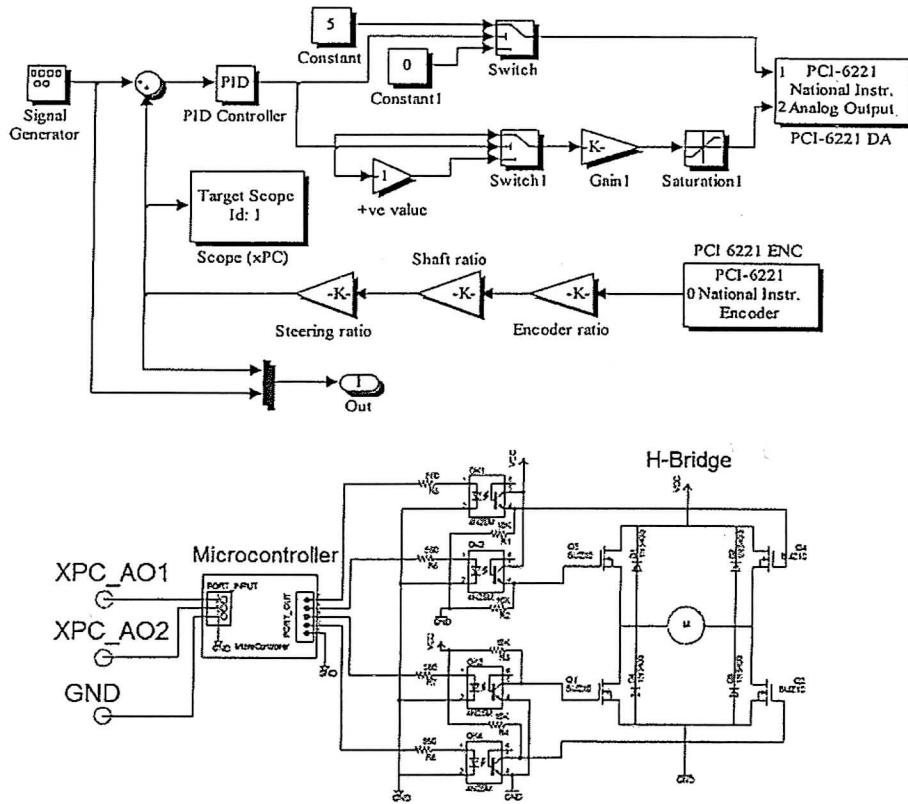

Figure 2 a) position controller develop for HIL via XPC target. b) DC motor circuit

The Output from XPC Target will be analog output voltage that used as input current driver motor circuit. The current driver consists of MOSFET H bridge circuit for DC motor and ATMEGA 32 microcontroller. The Microcontroller will receive 2 inputs from XPC. The first one is for reverse forward switch in H bridge and the second one is used for motor speed & torque analog signal that will be converted by microcontroller to generate PWM signal for DC motor.

Experimental results

The position tracking test for DC motor is performed to ensure the motor could follow the desired steering input. When steering wheel is turn by giving input signal, the DC motor tend to follow the desired signal by rotating the pinion angle which than pull or push the tie rod end to turn the tires to the desired angle.

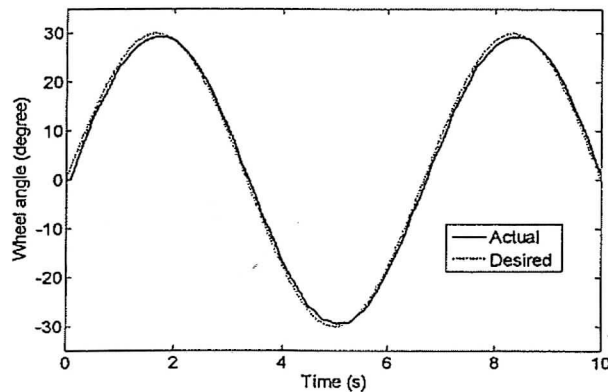

Figure 3. Positioning tracking for DC motor

To simplify the relationship between the rack and pinion steering mechanisms, the rack displacement is assumed directly proportional to the pinion rotational angle with relationship $Y = 0.00005X - 0.001$. From automatic steering system model, the correlation between displacement of rack and wheel angle can be defined as shown in Fig. 5 b. The maximum length of 60.5 mm will provide 30.5° tire angle from longitudinal axis.

Conclusion

The Hardware-in-the-loop Simulation (HILS) for automatic steering system have developed in this paper where provide a better tool to study the steering control system. The relationship of steering rack displacement and pinion angle is achieved by perform experimental measurement for actual rack and pinion steering linkage system. A result from sine input simulation demonstrates a good performance where it's closely follows the trend occurred through HILS experiment with acceptable error. The relation between rack displacement can be assumed directly proportional to the pinion angle with $Y = 0.00005X - 0.001$. The maximum rack displacement of Malaysia passenger car from normal position is 60.5 mm that provide maximum tire angle 30.5°.

Acknowledgement

This work is supported by the University Teknikal Malaysia Melaka (UTeM) through FRGS-F0079 project entitled "Development Of Lateral and Longitudinal Driver Model for Autonomous Vehicle Control" lead by the author. This financial support is gratefully acknowledged.

References

- [1] A. Khodayari, A. Ghaffari, S. Ameli, Historical review on lateral and longitudinal control of autonomous vehicle motions, IEEE International Conference on Mechanical and Electrical Technology. (2010) 421-429.
- [2] A.Rahman Hanzaki, S.K.Saha, P.V.M.Rao, Modeling of Rack and Pinion Steering Linkage using Multi-Body Dynamics, 12th International Federation for the Promotion of Mechanism and Machine (IFTOMM) Congress, Besancon, France, June 2007.
- [3] Naresh Kamble and S.K. Saha, Developing a Virtual Prototype of Rack and Pinion Steering System, International Journal Vehicle System Modeling and Testing, Vol. 2, No.1, 2007.
- [4] Bishop.R, Intelligent vehicle applications worldwide, IEEE Intelligent System and their Applications, Vol 15, No.1, 2000, pp 78-81,
- [5] Emm Ping, K.Hudha, Hanif Harun, Hisham Jamaludin, Hardware-in-the-loop Simulation of Automatic Steering, IEEE International Conference on Control Automation, Robotics and Vision, .Singapore, pp. 964-969.2010.
- [6] Hao Chen, Yali Yang, Ruoping Zhang, Study on Electric Power System based on ADAMS, Advance in Control Engineering and Information Science, Procedia Engineering 15(2011) 474-478, Elsevier, 2011.
- [7] H. A Rahmani, S. K. Saha, P. V. M. Rao, Analysis of a Six-bar Rack-and-Pinion Steering Linkage, International Mobility Engineering Congress & Exposition 2005~SAE India Technology for Emerging Markets , 2006.
- [8] Youchun Xu, Xiao Wang, Xianbing Zeng Yongsheng Peng Yongjin Zhang, Yi Yuan, A Hardware-in-the-loop Simulation Test- platform for the intelligent vehicle's steering control system, IEEE, 2009.
- [9] Mathew Lawson and Xiang Chen, Hardware-in-the-loop simulation of Fault Tolerant Control for an Electric Power Steering System, IEEE Vehicle Power and Propulsion Conference (VPPC), September 2008,Harbin , China.