

STS Motion Control Using Humanoid Robot

Mohd Bazli Bahar, Muhammad Fahmi Miskon, Norazhar Abu Bakar, Fariz Ali and Ahmad Zaki Shukor
Department of Mechatronic, Faculty of Electrical Engineering, Universiti Teknikal Malaysia Melaka,
76100 Durian Tunggal, Melaka, Malaysia

Abstract: This study presents the development of Sit to Stand (STS) motion control method. The main challenge in STS is in addressing the lift-off from chair problem. In solving the problem, the main components of the humanoid STS motion system involved are the (1) phase and trajectory planning and (2) motion control. These components should be designed so that the Zero Moment Point (ZMP), Centre of Pressure (CoP) and Centre of Mass (CoM) is always in the support polygon. Basically, in STS motion control there are two components, 1. Action selector and 2. Tracking controller. The STS motion control should be able to operate in real time and continuously able to adapt any change in between the motion. In this way, the accuracy of the controller to rectify the motion error shall increase. The overall proposed method to perform the STS motion is designed to have two main phases. (1) CoM transferring that implements Alexander STS technique and (2) Stabilization Strategy that used IF-THEN rules and proportional velocity controller. This study focuses on the presentation of the development of second phase which are 1. The development of the IF-THEN rules as the action selector that operates in real time to assist the proportional controller in making the best decision and, 2. The development of Proportional Gain Identification for the proportional velocity controller that is capable to change the gain implementation by referring to the define region that represent the motion condition. The validation of the proposed method is done experimentally using NAO robot as the test platform. The coefficient of the gain identification for the proportional controller was tuned using NAO robot that was initially set at sitting position on a wooden chair. The inclination of the body from a frame perpendicular with the ground, angle γ is observed. Coefficient that gives the lowest RMSE of angle γ trajectory is taken as a constant. Results show the proposed control method has reduced the (Root Mean Square Error) RMSE of the motion from 6.6858° when all coefficient is set as the same to 4.0089° after the coefficient at all defined region have been identified.

Keywords: Alexander technique, control method, NAO robot, STS

INTRODUCTION

The study of Sit to Stand motion (STS) gives high impact to the robotics field particularly in rehabilitation (Chuy *et al.*, 2006), exoskeleton (Strausser and Kazerooni, 2011) as well as humanoid robotics. Research in the STS field will promote the advancement of common humanoid motion hence make a robot more humanlike. With the capability of STS motion, the robot can be set at sitting position as a default home position and can be used for the purpose of long period application such as security and domestic robot. STS capability can also be implemented to other similar system such as exoskeleton robot, orthosis robot and FES system. In humanoid robotics field, the STS study has not been given emphasis until year 2010 (Mistry *et al.*, 2010). As far as 2013, groups have been identified to publish study of STS on humanoid are Mistry *et al.* (2010), Kaicheng *et al.* (2009), Pchelkin *et al.* (2010), Sakai *et al.* (2010), Xue and Ballard (2006), Jones (2011), Faloutsos *et al.* (2003), Kuwayama *et al.* (2003), Iida *et al.* (2004a) and Sugisaka (2007).

The main challenge in STS is addressing the lift-off from chair problem. The lift-off problem occurs when support polygon's area becomes smaller (initially positioned where hip touches the chair and feet touches the ground but becomes smaller when only the feet touches the ground) in a short period (Mistry *et al.*, 2010; Riley *et al.*, 1995). The phenomena is proven clinically in Millington *et al.* (1992) where the result showed that many parameters including torque at each joint and position of CoM need to be controlled at this point within a short period (9% of STS cycle). Failure to overcome this problem will cause the humanoid robot to fall on its back. This phenomena is called sitback failures in Riley *et al.* (1995). The lift-off problem is also caused by the actuator at the ankle that is not able to rotate the whole body in balancing the STS motion (Pchelkin *et al.*, 2010).

In solving the problem, the main components of the humanoid STS system are the:

- Phase and trajectory planning
- Motion control (Mistry *et al.*, 2010)

These components should be designed so that the Zero Moment Point (ZMP), Centre of Pressure (CoP) and Centre of Mass (CoM) stay in the support polygon. Combination of a proper phase, the right controller and trajectory planning will solve lift-off problem.

For the first component, improper phase and trajectory planning will cause the robot joints to be in awkward positions. For example, at sitting position, if a robot bend forward too much, its ankle joint will be unable to provide enough force to balance the STS motion (Pchelkin *et al.*, 2010). There are several phase that have been introduced to plan a proper trajectory in STS motion. Stability strategy and momentum-transfer is used by Riley *et al.* (1995). Knee strategy and the trunk-hip strategy are another named that have been called to represent the motion (Coghlin and McFadyen, 1994). Other than identifying the need of the motion then separate those into phases, Fu-Cheng *et al.* (2007) choose to implement an Alexander STS technique into the robot motion to plan the CoM position during STS movement. Human demonstration is another method used in Mistry *et al.* (2010) to obtain the CoM and joint trajectory to perform stable human-like STS motion.

The second component i.e., motion control concerns on how well a humanoid robot follows the planned trajectory. The challenge is to control the whole body to manage how and when the system should react (Prinz *et al.*, 2007). A good control method also helps to solve the phase planning problem as mention in Konstantin Kondak (2003). There are two aspects that need to be considered in STS motion control that is:

- Action selection
- Tracking the planned trajectory

Action selection concerns on selecting the appropriate action to be taken in different robot condition. Tracking the planned trajectory concerns on ensuring accuracy of robot motion in joint or cartesian space.

Action selector: The function of action selection is to choose the proper effort at certain condition such as different phase, robot position, or time interval. It is desirable to have action selection method that can adapt to change in STS motion in real time. Selection of appropriate action has been performed in the study of others using several methods.

One of the approaches proposed is using the IF-THEN rules (Rasool *et al.*, 2010) as the action selector. The rules are set based on the knee joint flexion. When the joint achieved certain degree, the rules will activate a controller that has been set at that moment. Another method introduced in Prinz *et al.* (2007) is a high-level controller that based on the phases planned by the author. A set of action has been design at every phase and the high-level controller will active the action when the system entered the phase. The study is mostly

the same with Matsui (2010) where the optimal controller is changing with the phase change. Both methods in Prinz *et al.* (2007) and Rasool *et al.* (2010) are not adaptable to the motion changes in real time because the rules are set based on a constant variable along the motion. Thus these approaches are not adaptable to real time change and not suitable for STS motion that needs a different phase or path.

In another work, an EMOSIAC (Extended Modular Selection and Identification for Control) was used as a controller and also as a soft selector to activate certain modules (Andani *et al.*, 2007). The EMOSIAC is more adaptable to the real time based on the system updated the next trajectory refer from the inverse and forward kinematic of each joint. However, the method have to undergoes learning process before it can be implement because it is a feedforward controller.

The level of selection capability of the methods discuss earlier is focused on phase, robot position, or time interval as describe before. The selector should also able to operate in real time such as in Andani *et al.* (2007) with addition of feedback information from the motion. For this reason, this study presents a new approach to select appropriate action based on IF-THEN rule using COP position. This approach is not considered before by others since they used simulated environment where the real COP data is lacking. Since in this project hardware experimentation is involved, the COP data can be acquired naturally by using force sensitive resistor embedded in the robot's feet.

Tracking the planned trajectory: In tracking the planned trajectory, a controller that monitor the motion in real time is also needed. The controller should be able to minimize the error i.e., difference between the planned and the actual trajectory performed by the robot. In performing STS motion at multiple chair heights, control system that is able to rectify the motion error while the environment variation is taken into account is crucially needed.

In Mughal and Iqbal (2006a, b) the optimal H_2 controller was used as a tracking scheme to perform STS motion using biped model. Additionally, there is also a combination of H_2 and H_∞ optimal controller developed in Mughal and Iqbal (2008) with the same purpose to perform STS motion using biped model. The optimal controller design is based on optimal solution for the system. It is most suitable in that environment but may not be the optimum solution for other system or environment.

PID controller has also been implemented in Andani *et al.* (2007) as a feedback controller while the whole system was monitored by the EMOSIAC as mention in action selection. The PD controller was also used in Jones (2011) but the author has combined the controller with the root orientation correction and a virtual force feedback loop to perform STS motion using biped model. From the review, the PID or PD

controller cannot be used alone to stabilize the STS motion. In both proposed methods, the authors have combined the PID and PD controller with other type of controller that function as an action selector or additional feedback to the system. The reason is STS motion is a nonlinear motion while PID or PD in a linear controller.

The combination of action selection and tracking controller was also done in Prinz *et al.* (2007) and Rasool *et al.* (2010) where both have implemented a fuzzy controller to track the planned trajectory. The fuzzy system in Prinz *et al.* (2007) give the required joint torque to the simulation robot and Rasool *et al.* (2010) used the fuzzy compensator in modifying the state space of the motion. The problem when designing a fuzzy system is the need of knowledge in the motion itself before heuristic approach can be used to set up the fuzzy parameter. It is crucial to repeat the process if the fuzzy controller is implemented in different environmental setting or for different type of robot.

Another approach in artificial intelligence system to perform STS motion is through learning process such as in Faloutsos *et al.* (2003), Iida *et al.* (2004b), Kuwayama *et al.* (2003) and Kanoh and Itoh (2007). The learning process has to be done until the robot able to stand. A number of trials are needed before the system can operate well. Logically, the method should able to adapt to the change of environment or system but the controller have to repeat the learning process before it generates the best motion. In Sakai *et al.* (2010), the author introduce Multi-valued Decision Diagram (MDDs) where the same problem may happen when facing with different environment or system.

From the review, AI controller is more adaptable when compared to the PID or optimal controller. However, AI controller requires time and many sample of STS motion for learning. To overcome these limitations, a method that is both adaptable and does not require many STS motion sample is proposed. The proposed method is a non-linear controller that is able to change the motion of the robot based on the feedback given by the actual STS motion in real time. There are related works that uses feedback to change the robot motion such as in Konstantin Kondak (2003). However, the feedbacks are theoretically calculated since their work is done through simulation only.

This study presents a controller that is implemented on a real hardware. Thus feedback from the motion could be acquired in real time. This project proposed the use of CoP reading to manipulate the gain of a proportional controller so that the controller is adaptable to the real time condition of the STS motion. The method decreases the heuristic by calculating the real velocity of the motion and constant gain is change by the real value of CoP position.

Summary of contribution: There are two contributions presented in this study. Firstly, the implementation of IF-THEN rules that function as an

action selector. The rules are set based on the CoP position and angle y reading at each moment in the motion. The action changes every time to ensure the effort given is the most suitable at that time. The concept is explained in system overview. Secondly, a Proportional Gain Identification method is proposed to ensure the controller is suitable for tracking whole STS motion. The gain is change based on the CoP position while the velocity of the whole body becomes a reference to the controller. The detailed explanation of the second contribution is stated in system overview.

METHODOLOGY

System overview: Figure 1 shows the system overview of the proposed sit to stand motion. The system is designed to have two main phases:

- CoM transferring
- Stabilization Strategy

In the CoM transferring phase, the trajectory of the robot motion is planned based on Alexander STS technique. The Alexander technique focus on decreasing the force needed to perform the STS motion. In this research, bending to front and ankle joint flexion is made to bring the Head-Arms-Torso system (HAT) CoM into the support polygon. For the case of NAO robot used in this project, it is located at 0.03 cm from the ankle joint of the robot.

This study focuses on the improvement of the performance of Phase 2. Phase 2 starts when the HAT CoM is fully transferred in phase 1. In phase 2, the system will control the robot motion to a fully standing position using speed control. To determine a suitable speed parameter value, IF-THEN rules are set. The rules give a desired speed gain. The gain is varied by the Centre of Pressure (CoP) position in x-axis. For NAO robot, the controller used three types of sensor to control the motion which is gyroscope, accelerometer and force sensitive resistor. The gyrometer and accelerometer is used to get the angle y reading which refer to the angle between the robot and perpendicular line from the ground as in Fig. 2. Four units of FSR at the robot's feet give a CoP reading in meter.

NAO robot configuration: NAO robot has been used for experimentation purposes. There are three types of sensor embedded in NAO i.e., gyroscope, accelerometer and force sensitive resistor. The gyrometer and accelerometer generates the angle y reading which refer to the angle between the robot and perpendicular line from the ground as in Fig. 2. Four units of FSR at the robot's feet give a CoP reading in meter. The motor speed is between 210 to 230°/sec with load. All of the motor for one leg (3 unit motor) is aligned to each other's.

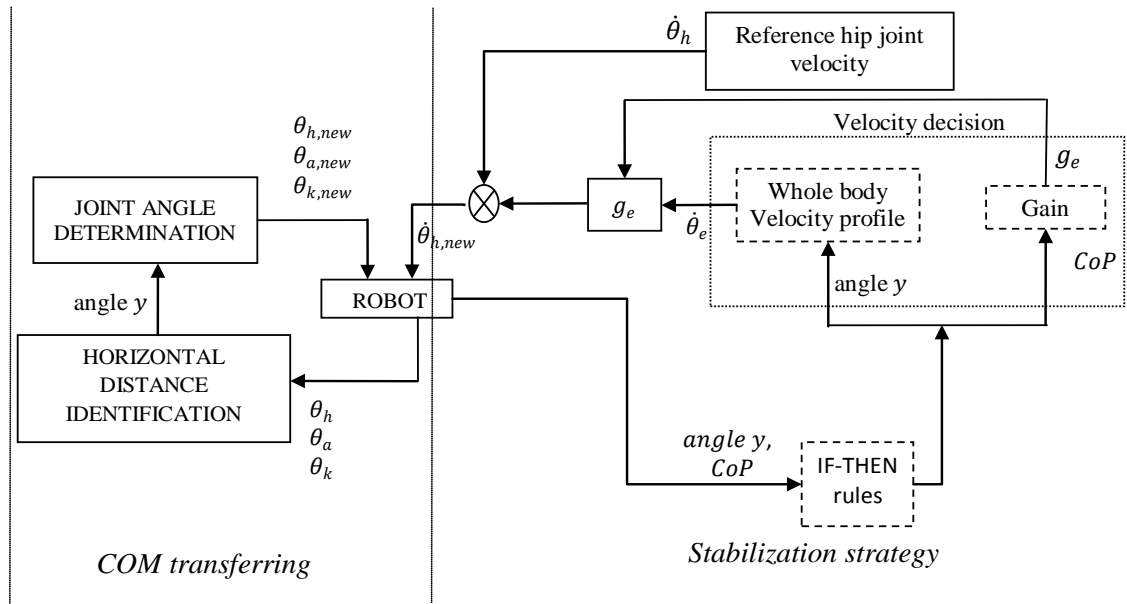

Fig. 1: Overall system overview for stable sit to stand motion

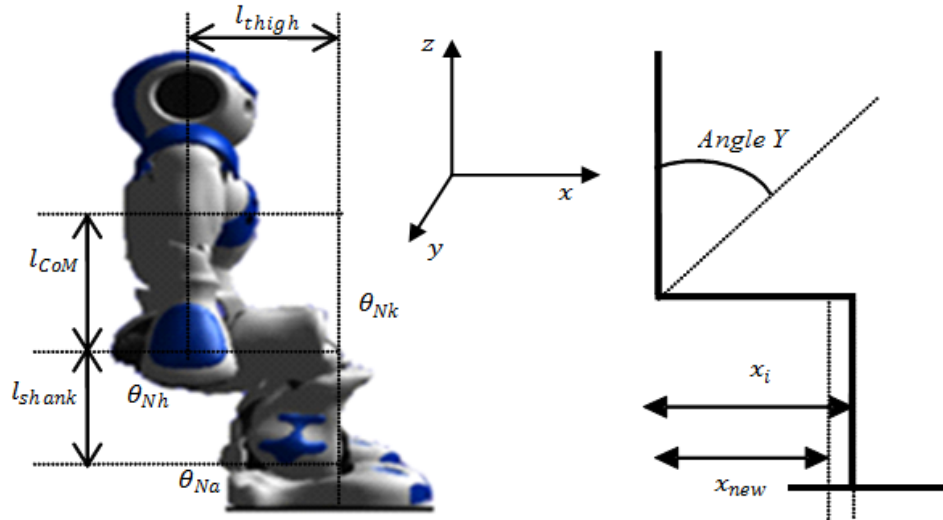

Fig. 2: The normal position of NAO robot at sitting position

System configuration: The proposed method has two constant variables that need to be set before it can be implemented. There are:

- CoM position
- Region boundaries

The position of CoM between the CoM transferring phase and stabilization strategy phase is assume the same i.e., the CoM is equal to the HAT CoM. Located at the centre of the HAT while both hand is parallel with the body. The region boundaries are determined by experiment procedure with the objective of determining the minimum stability edge before been used in the proposed method as discuss in below section.

CoM transferring phase: In CoM transferring phase, HAT CoM is transfer into the support polygon to facilitate the stabilization strategy. The path planning was referred to the AT. To keep the stability of the robot, the CoM or HAT CoM in this case must support by any part of the robot body that has contact with the ground or the chair surface. Before hip lifted from the chair surface, the path should able to transfer the HAT CoM near to the feet. This is because when the robot lifts from the chair's surface, the feet are only parts that contact with the ground. This phase has two processes:

- Horizontal distance, x_i identification
- Joint angle, θ_h and θ_a determination

In the first process the horizontal distance between the HAT CoM of the robot with the ankle joint is identified. The process functions as automatic distance identification that crucially need by the second process to automatically determine the path needed. In this process, the horizontal distance x_i is determined by using Eq. (1). In Eq. (1), hip joint unit, a_h can be ignored when the HAT CoM position is adjusted to be parallel with the hip joint position using Eq. (2):

$$x_i = \pm[a_h] + [a_k] \pm [a_a] \quad (1)$$

where,

$$\begin{aligned} \alpha_h &= \sin(|diff(\theta_{Rh}, \theta_{Nh})|) \times l_{COM} \\ \alpha_k &= \cos(|diff(\theta_{Rk}, \theta_{Nk})|) \times l_{thigh} \\ \alpha_a &= \sin(|diff(\theta_{Ra}, \theta_{Na})|) \times l_{shank} \end{aligned}$$

$$\theta_{h.new} = \theta_{Nh} + [\theta_{Nk} - \theta_{Rk}] \quad (2)$$

The *diff* refers to difference between hip, knee and ankle joint position read from sensor, θ_{Rh} , θ_{Rk} , θ_{Ra} with hip, knee and ankle joint position at normal position, θ_{Nh} , θ_{Nk} , θ_{Na} . l_{COM} is the length between hip joint to the HAT CoM in *cm* and l_{thigh} and l_{shank} is the length of thigh and shank. Figure 2 shows the position of each joint and the normal position that has been defined.

Typical parameter values for standard NAO sitting position use in this research is shown in Fig. 2:

$$\begin{aligned} \theta_{Nh} &= -75.5^\circ \\ \theta_{Nk} &= 90^\circ \\ \theta_{Na} &= -7^\circ \\ l_{COM} &= 15 \text{ cm} \\ l_{thigh} &= 10 \text{ cm} \\ l_{shank} &= 10.3 \text{ cm} \end{aligned}$$

With Eq. (1), the distance of HAT CoM with ankle joint can be determine for any robot after normal sit position has been defined.

In the second process, joint angle θ_h and θ_a is determined. Value x_i is used to identify angle change at each joint. The joint angle need to be identified to make sure that the HAT CoM is in the Stability Region (SR). Following the Alexander technique, the method focuses on hip and ankle joint to shift upper body weight into the stability region. In the first move, the method brings the body to the front. By using Eq. (3), the needed hip joint angle change $\theta_{h,need}$ can be calculated:

$$\theta_{h,need} = \theta_{Rh} - [-90 - abs(\cos^{-1}(x_{new}/l_{COM}))] \quad (3)$$

Results from Eq. (3) are observed to make sure that the robot does not exceed the hip joint limitation. The limitation at hip joint leads to the needed of ankle joint

change. At this point, remaining distance between HAT CoM and stability region edge is calculated using Eq. (4):

$$x_{remain} = x_{new} - abs[(l_{COM} \times \cos(90 - (\theta_{Rh} - \theta_{h.new})))] \quad (4)$$

The remaining distance, x_{remain} determine whether the ankle joint change is needed or not. If $x_{remain} = 0$, the system proceed to the second phase. However, if x_{remain} has a positive value a new ankle joint is calculated using Eq. (5):

$$\theta_{a.new} = \theta_{Ra} + [-(\sin^{-1}(x_{remain}/l_{shank})) - abs(\theta_{Na} - \theta_{Ra})] \quad (5)$$

After both hip and ankle joint has their values, the system moves the robot to the desired position starting with hip than followed by ankle.

The trajectory of the hip and ankle joint is generated using the cubic polynomial function. With the cubic polynomial trajectory generation the joint speed was decreased at the first and the end of the motion. This condition directly affects the dynamic of the whole body motion.

Hip and ankle joint will rotate to the new angle while knee joint is the same. Firstly, hip joint will move than followed by the ankle joint after hip joint has already at the destination. In between this motion, system will always monitor the projected angle y reading to make sure the robot does not fall forward. Hip or ankle joint will stop moving when angle y reading is more than the limit variable to control the motion from giving to much forward force.

With the proposed algorithm, the path generates is referring to the AT while it can operate automatically if the environment i.e., chair height is changing. The algorithm also generates path that consider the body limitation and choose the most appropriate joint action. A minimum feedback taken from angle y reading is made to ensure the path not generates a high momentum at the end of the first phase. This is because the high momentum will give more difficulty for the second phase to control the motion.

Stabilization strategy: In this phase, controller input is CoP, in meter, angle y , θ_y and joint angle, $\theta_{Rh/Rk/Ra}$. The controller output is the new hip joint target angle, $\theta_{h.new}$ and joint speed, $\dot{\theta}_{h.new}$. Firstly, the controller undergoes IF-THEN rules to choose the correct direction, velocity and gain. The gain and rules is based on the CoP position in three types of regions as depicted in Fig. 3. The boundaries of the regions are the optimum stability region edge value. The stability region edge values are usually determined heuristically. However in this research the value is obtain using experimentation by testing which HAT CoM position in

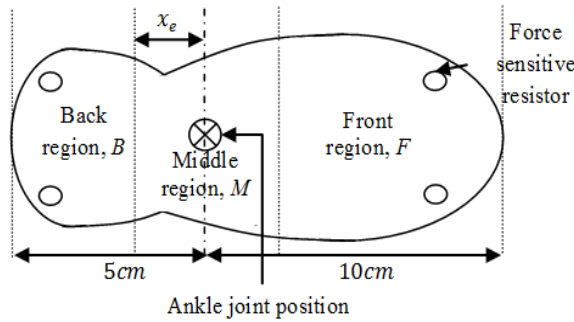

Fig. 3: Region defines at robot foot base on CoP position

the x-axis that not makes the robot fall. For NAO robot used in this study, the stability region edge value is found to be 0.03 m from the ankle joint. The boundary edge was set slightly smaller than the stability region edge, x_e i.e., 0.02 m because the acceptable area must not exceed 0.03 m to the back of the ankle joint. The region area also cannot set too small to avoid over sensitivity of the system.

The proposed IF-THEN rules: Generally the rules are set based on CoP and angle y reading. The dependant variables i.e., the velocity, direction and the type of gain will change according to the CoP and angle y reading. In principal, the dependant variables are set to ensure that the STS motion is always in favor of producing less angle y error. The amount effort needed for minimizing the angle y error is also considered when setting the dependant variables. For example, the direction of the hip joint only changes if the system senses that the angle y trajectory is smaller than planned and CoP is located at region B as in Fig. 3. For other conditions, velocity and gain are the only change made because rapid change in direction will worsen the stability of the STS motion.

The robot is defined as stable when the CoP is in region M and becoming unstable when the CoP is in region B and F as shown in Fig. 3. The robot hip joint angular velocity, $\dot{\theta}_{h.new}$ and direction, $\theta_{h.new}$ depends on whether the CoP is in the region M or region B and F at the front or the back of the foot. Thus, the IF-THEN rules used as the action selection controller, it was set as follows:

- IF : Angle $y > \text{Plan}$ AND $\text{CoP} > 0.02$ cm
 THEN : 1. Hip joint velocity is increased, 2. HAT moving backward direction 3. Gain is based on region F
- IF : Angle $y < \text{Plan}$ AND $\text{CoP} < 0.02$ cm
 THEN : 1. Hip joint velocity is the body velocity error, 2. HAT moving forward direction 3. Gain based on region B
- IF : Angle $y > \text{Plan}$ AND $(-0.02 < \text{CoP} < 0.02)$

- THEN : 1. Hip joint velocity is increased, 2. HAT moving backward direction, 3. Gain based on region M
- IF : Angle $y < \text{Plan}$ AND $(-0.02 < \text{CoP} < 0.02)$
 THEN : 1. Hip joint velocity is decreased, 2. HAT moving backward direction 3. Gain based on region M

In the first case, the angle y and CoP reading represent that the robot is approaching to fall forward. The system action is increased the HAT velocity while moving backward. The proportional gain given to the controller is based on unstable region F . In the second case, it represent the vice versa of the first case. The action made is changing the HAT direction to the front while the velocity is new velocity from the controller. Another two cases represent that the CoP is in the stable region M but angle y reading is moving apart from the planned trajectory. In both cases, only the angular velocity of the HAT is change. Increased if the angle $y >$ than planned, decreased if the angle $y <$ planned. The proposed IF-THEN rules are not undergoes any fuzzification process to decrease the heuristic approach. Furthermore, the rules are operating in real time where the reading of angle y and CoP position is updated in every moment. After the dependent variables have been choose, the system will proceed to a velocity proportional controller as illustrated in Fig. 1 after the IF-THEN rules box.

The proposed proportional gain, g_e identification method: The proposed method implemented a proportional velocity controller with adjustable gain. The explanation of the proposed method begins with the gain identification method and then the process to identify the angular velocity that used as the controller output.

Proportional gain: The gain is determined by the CoP position. As the CoP is changing every moment in the whole motion, the gain fed to the proportional velocity controller is also changing with it. In this way, the gain provide to the controller is the most suitable value to rectify the error. To do so, partitioning of region as in Fig. 4 is made to prepare the best coefficient for the CoP reading before used as the gain. The coefficient is set based on the defined region so that the value is only effected the gain when the effort is really needed. Furthermore, the coefficient used to enhance the CoP reading before used as a gain.

The coefficient, G_1 and G_2 are tuned by changing the value until the angle y trajectory produces a lowest RMSE. Detailed on the tuning is discuss in the result.

The CoP reading is taken from one foot because the system is in 2 dimensions (X-Y) so positions of CoP are assumed to be the same between each foot. Firstly, the coefficient was multiply with the CoP

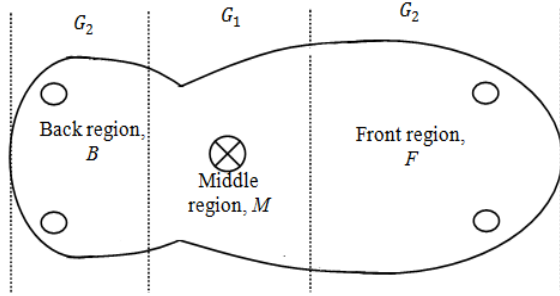

Fig. 4: Coefficient label in the defined region

reading to produces the gain, g_e as in Eq. (6). Result from Eq. (6) will be taken to the controller and produces a new hip joint angular velocity, $\dot{\theta}_{h,new}$ as in Eq. (7). In any cases set in the rules describe before, the gain is functioning in the same way. Effort of increase or decreasing the original hip joint angular velocity, $\dot{\theta}_h$ is not control in this section. The discussion on the proportional velocity adjustment is in the sub section velocity variable:

$$g_e = G \times (CoP) \quad (6)$$

$$\dot{\theta}_{h,new} = \dot{\theta}_{h,need} \times g_e \quad (7)$$

After the joint have reached the target position at time $t = t_f$, the controller need to keep the robot balance when $t > t_f$. The method to identify the gain at this moment is the same as before, $t < t_f$. However, the applied coefficient is different. From Fig. 5, the

coefficient is represented as G_3 . The coefficient G_3 is different from the G_1 and G_2 because at this moment, the robot should be in static position. The only motion left is due to the error before the robot achieves the target position. It is not suitable for the gain to implement the same coefficient as before because the requirement in controlling the movement is different i.e., G_1 and G_2 control the motion in dynamic and G_3 in static. To ensure the robot not tumbling down due to this error, the controller will rectify the error with the same methods i.e., control the velocity of the motion.

With the implementation of CoP reading and region coefficient as the prerequisite before the gain can be determine, the proportional velocity controller able to change the effort made corresponding to each moment in the motion. This has change the linear proportional controller into a controller that can adapt a nonlinear motion. The dividing of region that represent different coefficient can increase the sensitivity of the proposed method.

Velocity variable: From the rules, proposed method will change the hip joint angular velocity in order to rectify the error produce by the motion. STS motion is a circular motion where tangential and angular velocities exist at each moment in the motion. When there is momentum, friction and gravity interference in the motion, this tangential velocity will changed from what it was planned. The developed controller should able to decrease this change to ensure the motion is mostly the same as planned and produce a stable motion.

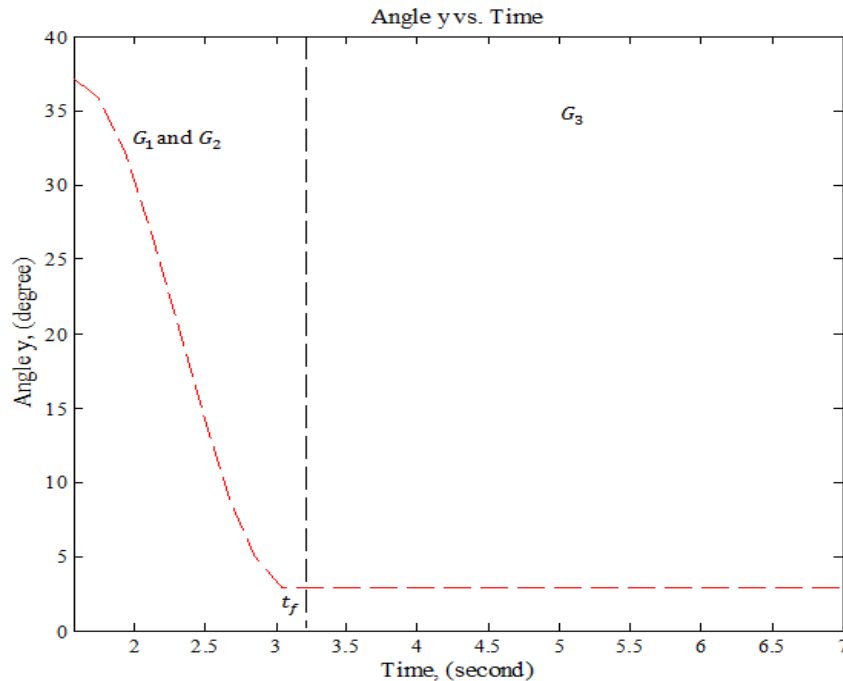

Fig. 5: Position of coefficient G_1 , G_2 and G_3 refer to the motion trajectory

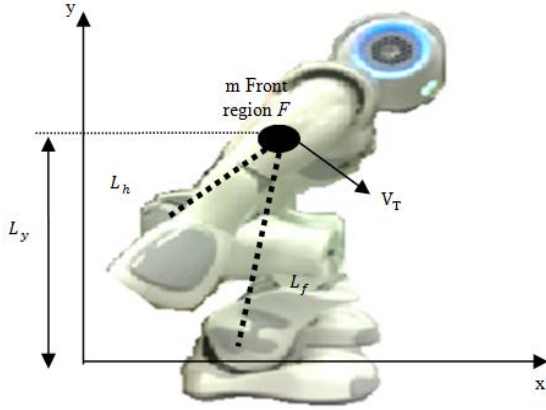

Fig. 6: Location of weight, m and the link of whole body link, L_f and body link, L_h

The tangential velocity of the whole body is proposed to be used as the tracking variable. To do so, the HAT CoM position is assumed as the end point of an imaginary link that start from the ankle joint refer as whole body link as shown in Fig. 6. From now, the CoM of the whole robot was set located at the HAT CoM as the mass of shank and tights was moving to each other in x-axis and the HAT give the most dynamic effect to the motion where in Hutchinson *et al.* (1994) it state that 10 to 15% dynamic contribution by the Hip joint (HAT) while knee and the ankle joint motion only less than 1%. Another link is the hip joint to the HAT CoM that becomes another system refers as HAT link.

The horizontal distance from ground to the centre of mass is, L_y obtained from the angle measurement. Using trigonometry concept, Eq. (8) is used to calculate the horizontal distance between ankle joint and the CoM:

$$L_y = Ych + Yck + Yca \quad (8)$$

where,

$$\begin{aligned} Ych &= |\cos(|diff(\theta_{Rh}, \theta_{Nh})|) \times l_{CoM}| \\ Yck &= |\sin(|diff(\theta_{Rk}, \theta_{Nk})|) \times l_{thigh}| \\ Yca &= |\cos(|diff(\theta_{Ra}, \theta_{Na})|) \times l_{shank}| \end{aligned}$$

The link for whole body, L_f is determined by Eq. (9) and the link for HAT, L_h is always same as the distance between CoM and hip joint, l_{CoM} :

$$\begin{aligned} L_{fP} &= \frac{L_y}{\cos \theta_{yP}} \\ L_{fR} &= \frac{L_y}{\cos \theta_{yR}} \end{aligned} \quad (9)$$

θ_{yP} and θ_{yR} represent the angle y plan and actual. The general torque equation for the whole body link is, $\tau_{net} = mgL \sin \theta$ that can also be represented by,

$\tau_{net} = mL^2 \ddot{\theta}$. By combining both equations, it will be as in Eq. (10). The final formula for plan and actual value is used to calculate the error of angle y as in Eq. (11):

$$\begin{aligned} mL^2 \ddot{\theta} &= mgL_f \sin \theta \\ \ddot{\theta} &= \frac{g}{L_f} \sin \theta \end{aligned} \quad (10)$$

$$\ddot{\theta}_e = \left[\frac{g}{L_{fP}} \sin \theta_{yP} \right] - \left[\frac{g}{L_{fR}} \sin \theta_{yR} \right] \quad (11)$$

From the acceleration error in Eq. (11), the velocity error is determined by integration of $\ddot{\theta}_e$ within a step time. From the angular velocity error of the whole body motion, the tangential velocity, V_T at HAT CoM is determined using Eq. (12). A needed hip joint angular velocity is determined using Eq. (13). With the new angular velocity, a new tangential velocity V_{Tnew} that counter the first tangential velocity generates by the whole body V_T was made by the HAT motion to ensure that the total V_{Tnet} is zero:

$$V_T = \dot{\theta}_e \times L_{fR} \quad (12)$$

$$\dot{\theta}_{h,need} = \dot{\theta}_h \pm \frac{V_T}{l_{CoM}} \quad (13)$$

The new direction of the hip joint, $\theta_{h,new}$ is determined base on angle y reading. From Eq. (11), $\ddot{\theta}_e$ will be a positive or negative value depending on the value of θ_{yR} . This in turn will influence the value of V_T and $\dot{\theta}_{h,need}$ in Eq. (12) and (13).

With $\dot{\theta}_{h,need}$, the new angular velocity, $\dot{\theta}_{h,new}$ have to consider the rules discuss before. In the first case, the angular velocity of the hip joint is increase. The increment is based on addition of original hip joint velocity, $\dot{\theta}_h$ at that moment with $\dot{\theta}_{h,new}$, where it is the result of $\dot{\theta}_{h,need}$ times gain based on the F region. In the second case, the hip joint angular velocity is only the $\dot{\theta}_{h,new}$ because there is a direction change. For another two cases, the original hip joint angular velocity is added with $\dot{\theta}_{h,new}$ when increasing is needed and minus with the $\dot{\theta}_{h,new}$ when the system needs to decrease the motion velocity.

RESULTS AND DISCUSSION

This section discuss in detailed the results of experiment conducted. The experiment objective is to validate the proposed stabilization strategy method. The expseriment was done using NAO robot Version 3.3. Controller scheme was written using python script and no other external sensor was used. In every test, both

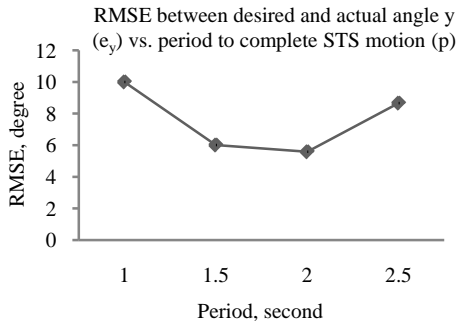

Fig. 7: RMSE of angle y trajectory with different STS motion period. (RMSE = 10 represent that the motion was collapse)

robot heels must touch the chair front legs and the test was repeated for 5 times. Angle y and CoP position is observed to study the performance. Performance was measured by using root mean square error, RMSE calculated between actual and plan angle y trajectory.

Results: NAO robot was set at sit position as in Fig. 2 using wooden chair. The chair height is 11 cm where knee joint is at 90° . This height is equal to the total length of shank and feet thickness. Three coefficients, G_1 , G_2 and G_3 were tuned until a lowest RMSE value of the angle y trajectory is found. The M region boundary is at -0.02 and 0.02 m. The B region is -0.02 to -0.5 m and F region is 0.02 to 0.1 m. Position 0.0 m of CoP is at the ankle joint (Fig. 3). At first, all G was set at 1 to find the suitable performance standing time. Result was shown in Fig. 7.

Let the coefficient for M region represented by G_1 and B and F region by G_2 as in Fig. 4. Another gain coefficient to control the robot after complete stand position is G_3 . G_1 and G_2 were set at 1000 and G_3 was varied until the RMSE become smaller. In range of 1000 to 3000, the smaller value of RMSE is 1.387° at $G_3 = 2500$. The RMSE was calculated from total performance time at 3.25 to 6 sec because at 3.25 sec the robot knee and ankle has reached the desired position (complete standing). Secondly, G_1 was varied

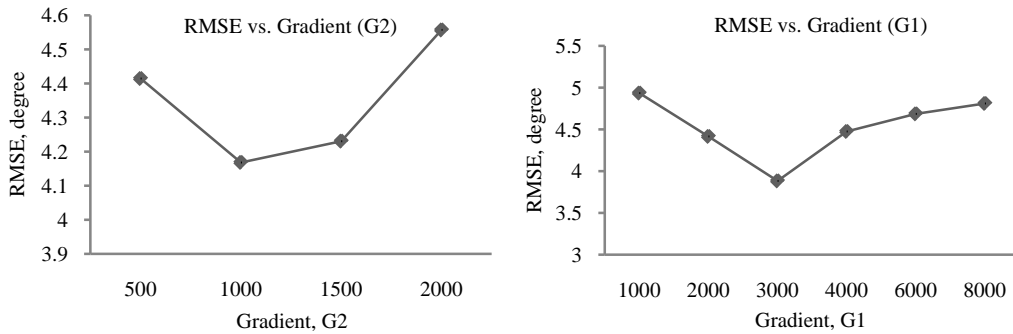
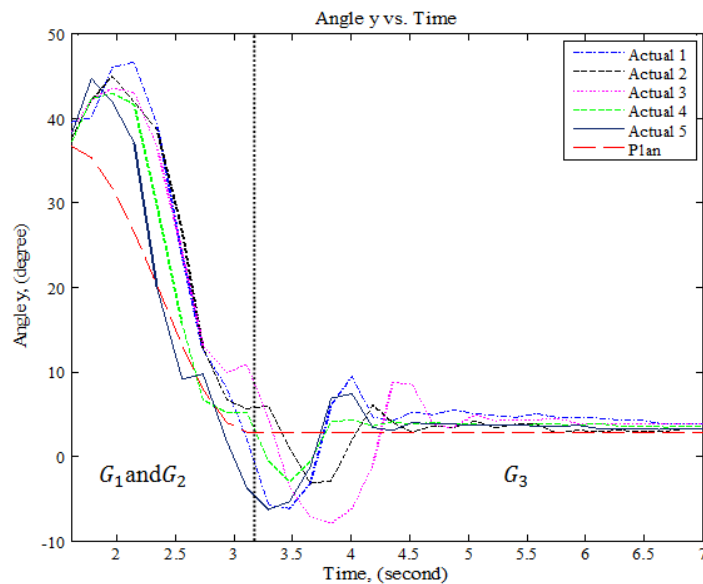
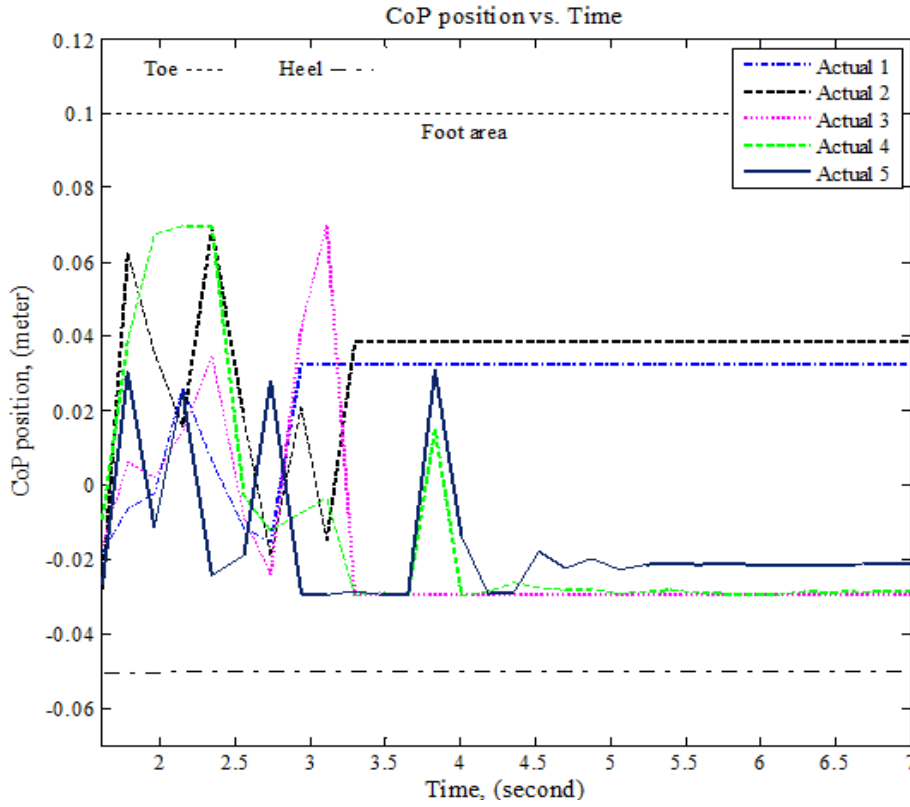

Fig. 8: Result for coefficient value of G_2 (first graph) and G_1



(a)



(b)

Fig. 9: Coefficient, $G_1 = 1000$, $G_2 = 1000$, $G_3 = 1000$, (a) the angle y trajectory, (b) CoP position

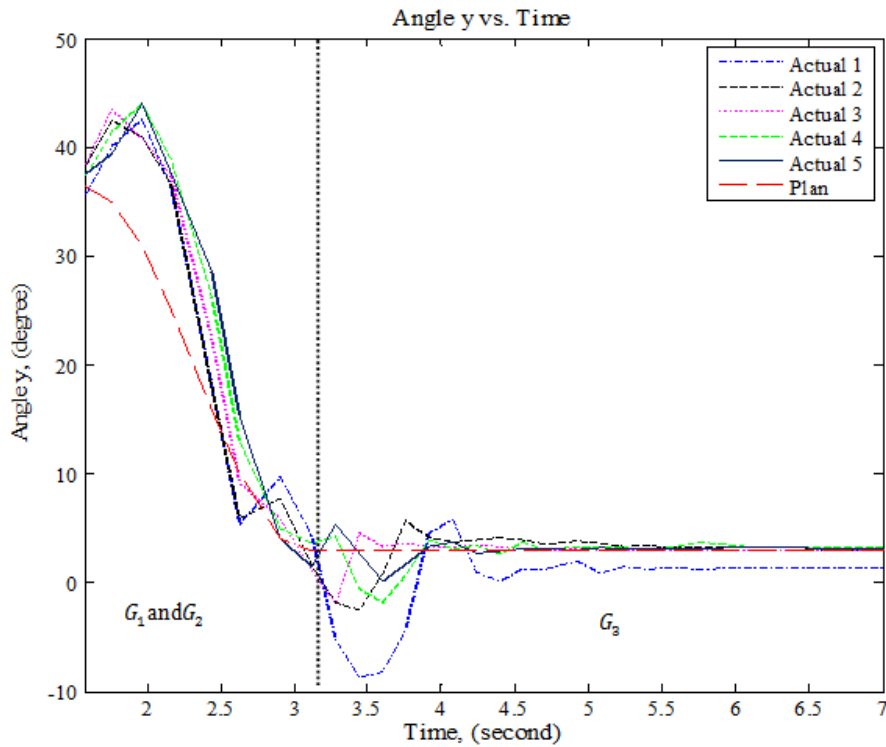

(a)

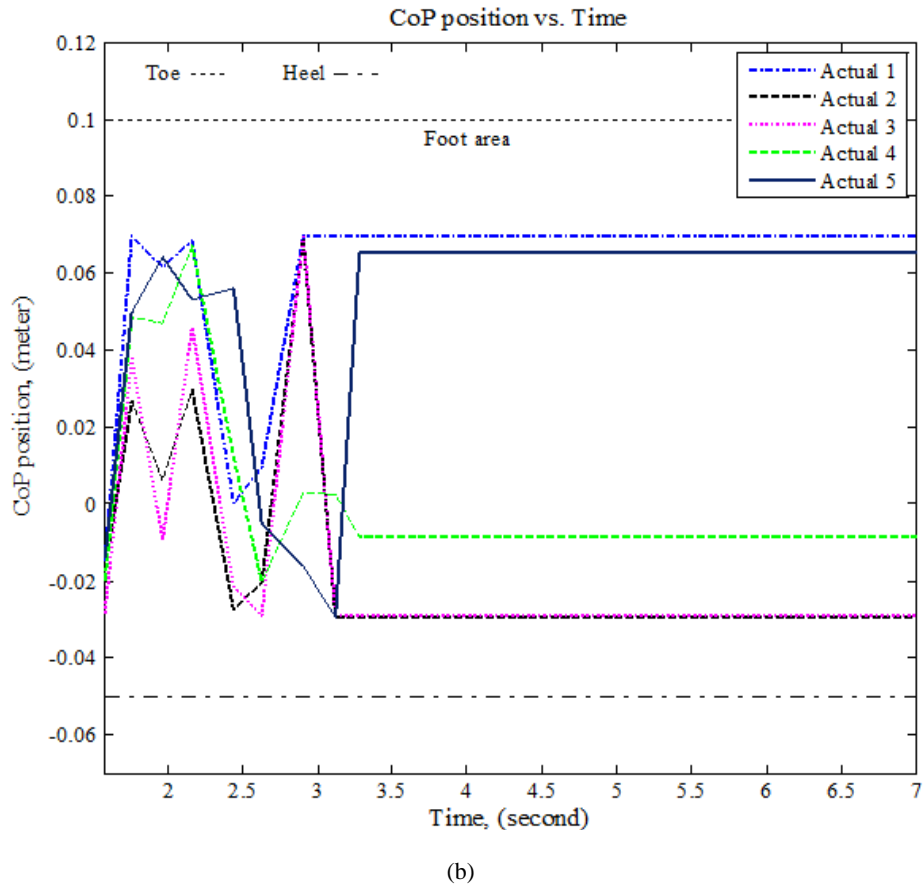
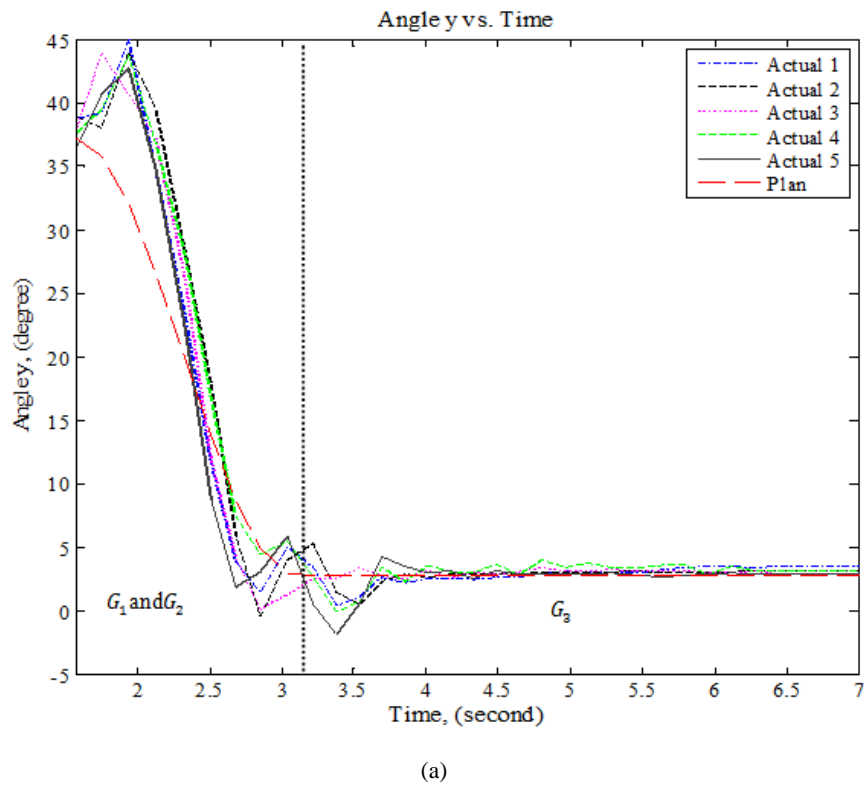
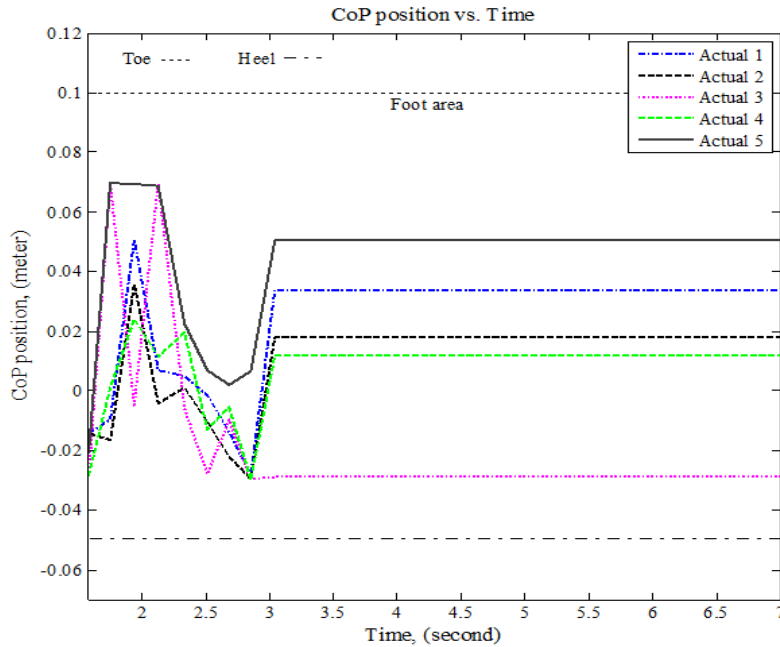

Fig. 10: Coefficient, $G_1 = 1000$, $G_2 = 1000$, $G_3 = 2500$, (a) the angle y trajectory, (b) CoP position





(b)

Fig. 11: Coefficient, $G1 = 3000$, $G2 = 1000$, $G3 = 2500$, (a) the angle y trajectory, (b) CoP position

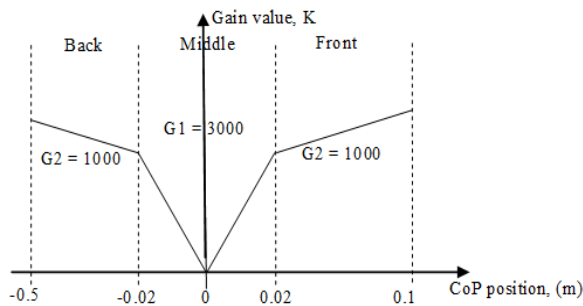

Fig. 12: The gain curve with the coefficient and CoP



Fig. 13: Motion of the robot when $G1 = 3000$, $G2 = 1000$ and $G3 = 2500$

with $G2 = 1000$ and $G3 = 2500$. The same method was used to find $G2$. Figure 7 and 8 shows the graph of RMSE with respect to the coefficient of $G1$, $G3$ and $G2$ while Fig. 9 until Fig. 10 and 11 shows the angle y and CoP readings from the robot. In Fig. 12, the curve of gain value within the region is presented.

The robot able to perform STS motion within 1.5 sec standing time which is start from 1.6 sec until 3.2 sec. The controllers switch to constant gain coefficient, $G3$ after 3.2 sec of operation after all joint has reached the target angle. Figure 13 shows the NAO robot motion after all coefficients has been identified.

Discussion: When all coefficients is equals to 1, the lowest RMSE is when standing period is 2 sec as shown in Fig. 7. However, the robot will need 3.5 sec to stand. To decrease the performance times, a suitable gain was needed to ensure that the proportional controller able to provide a velocity equivalent to the present error. From Fig. 9a, the average RMSE of angle y trajectory is 6.6858° when all coefficients were set at 1000. The angle y graph shows that the actual trajectory moved forward from the planned trajectory at start due to momentum generates in the first phase. The average actual trajectory at this moment is 44.60° . After 3 sec of operation, the actual trajectory once again move to the back (-6.3°) from the plan trajectory (2.86°) after all joints has stop. This happen because the new velocity provide by the controller to decrease the error at the beginning of the motion is affecting the motion at this moment. Furthermore, the gravity forces acting on the robot bring the system backward as the last body

motion is in that direction. The robot motion just not ends until 3.5 sec but begins to move forward. This motion was influenced by the controller and the gravitational force. The CoP position in Fig. 9b also shows that the pressure continuously changing until 3 to 5 sec before start to stable. The CoP is considered stable as it always in the foot area.

The error happen after all joints already at the target position was decrease by tuning the coefficient $G3$. In Fig. 10, the actual trajectory of angle y when all joints have already stopped gives less error when compared with the graph in Fig. 9. The new velocity generated by the controller is able to counter the error cause by the gravitational force and previous velocity that act on the body. CoP position in Fig. 10 start to stable after 3.28 sec of operation. However, the changing of CoP position still occurs at the beginning. Similarly, the trajectory of angle y , the actual trajectory is not according to plan. This is due to the effect of coefficient $G3$ where it's only active after all joints are at the target position.

To ensure the system provides the most suitable gain, $G1$ and $G2$ was needed. The presence of both coefficients has increase the stability of the motion where average RMSE for angle y trajectory decreased until 4.00968° as shows in Fig. 11. The angle y has already moved to the back after 2.5 sec of operation. This is because the region gives high sensitive to the system in controlling the motion. From the experiment, the M region needs high coefficient when compare to the B and F region as represent in Fig. 12. This is due to CoP reading is smaller in the M region than the other two regions. The gain coefficient boosts up the CoP value before it is used as gain value in the controller. However, if the coefficient used in the B and F regions, the gain will become larger than necessary.

The performance of angle y observed when system in stabilization strategy phase shown that the actual value was greater than plan. Overshoot of actual angle y trajectory happen at the beginning (mostly at 1.6 sec) for all graph represent in Fig. 9 until Fig. 11 because of the high momentum creates by the robot body at CoM transferring phase. Change in direction of all joints generates the momentum forward. The CoP reading also shown that initially, the pressure was located at the centre of the SP (-0.03 to 0.03 m) than quickly focused to the front. Between the graph in Fig. 9 and 11, the different of plan and actual angle y trajectory will cause the CoP located further from the origin (0.00 m).

At the end of the motion, the CoP reading is not consistently at one point between each test. However, the robot was able to stand completely based on actual angle y value that move closer to the plan value as time increased. Although the CoP is outside the defined stable region, the CoP is still in the foot area which the robot can stand stably because at this time, only small movement done by the robot. The last movement made by hip joint change to ensure that angle y moves closer

to the planned angle y trajectory as fast as it can. In Fig. 11 the graph has already stable after 4 sec of operation due to small error happen before completed the standing post. However, the graph in Fig. 9 only stable after 5 sec of operation.

CONCLUSION

The IF-THEN rules based on CoP position and angle y trajectory helps to increase the capabilities to make proper action. The proportional controller with gain feed from the defined region based on the CoP reading has increase the flexibility of the controller in handling a nonlinear motion. AT that is proposed as a guideline in gait planning able to transfer the HAT CoM into the define support polygon has increase the stability of whole motion. The proposed control method is able to control the robot in performing STS motion within 3.2 sec and the RMSE is 4.0021° . The robot will collapse if there is no control system implement in the motion. It is recommended for future work that the proposed control method is tested on other humanoid robot to test the robustness and its capability. Comparison with other control method that has been developed can be made to verify the effectiveness of the method using the same experiment tools. Furthermore, the STS dynamic model can also be diversified to identify the best model to be used in this system. In the future, the method and algorithm will be tested using various chair height to validate the CoM transferring phase for autonomous STS motion system.

ACKNOWLEDGMENT

The study was supported by Centre of Excellence, Robotics and Industrial Automation, Faculty of Electrical Engineering, Universiti Teknikal Malaysia Melaka.

REFERENCES

- Andani, M.E., F. Bahrami and P.J. Maralani, 2007. A biologically inspired modular structure to control the sit-to-stand transfer of a biped robot. Proceeding of the 29th Annual International Conference of the IEEE on Engineering in Medicine and Biology Society (EMBS, 2007), pp: 3016-3019.
- Chuy, O., Y. Hirata, W. Zhidong and K. Kosuge, 2006. Approach in assisting a sit-to-stand movement using robotic walking support system. Proceeding of the IEEE/RSJ International Conference on Intelligent Robots and Systems, pp: 4343-4348.
- Coghlin, S.S. and B.J. McFadyen, 1994. Transfer strategies used to rise from a chair in normal and low back pain subjects. Clin. Biomech., 9(2): 85-92.

- Faloutsos, P., M. Van De Panne and D. Terzopoulos, 2003. Autonomous reactive control for simulated humanoids. *Proceeding of the IEEE International Conference on Robotics and Automation (ICRA '03)*, 1: 917-924.
- Fu-Cheng, W., Y. Chung-Huang, L. Yi-Ling and T. Chen-En, 2007. Optimization of the sit-to-stand motion. *Proceeding of the IEEE/ICME International Conference on Complex Medical Engineering (CME, 2007)*, pp: 1248-1253.
- Hutchinson, E.B., P.O. Riley and D.E. Krebs, 1994. A dynamic analysis of the joint forces and torques during rising from a chair. *IEEE T. Rehabil. Eng.*, 2: 49-56.
- Iida, S., M. Kanoh, S. Kato and H. Itoh, 2004a. Reinforcement learning for motion control of humanoid robots. *Proceeding of the IEEE/RSJ International Conference on Intelligent Robots and Systems (IROS, 2004)*, 4: 3153-3157.
- Iida, S., S. Kato, K. Kuwayama, T. Kunitachi, M. Kanoh and H. Itoh, 2004b. Humanoid robot control based on reinforcement learning. *Proceedings of the International Symposium on Micro-Nanomechatronics and Human Science and The 4th Symposium on Micro-nanomechatronics for Information-based Society*, pp: 353-358.
- Jones, B.J., 2011. Rising motion controllers for physically simulated characters. M.Sc. Thesis, University Of British Columbia.
- Kaicheng, Q., G. Feng, L. Wei and Y. Jialun, 2009. Analysis of the state transition for a humanoid robot SJTU-HR1 from sitting to standing. *Proceedings of the International Conference on Mechatronics and Automation (ICMA, 2009)*, pp: 1922-1927.
- Kanoh, M. and H. Itoh, 2007. Obtaining Humanoid Robot Controller Using Reinforcement Learning. Vienna. Retrieved from: <http://www.intechopen.com/download/df/241>.
- Konstantin Kondak, G.H. 2003. Control and Online Computation of Stable Movement for Biped Robots. *Proceedings of the IEEE/RSJ International Conference on Intelligent Robots and Systems (IROS, 2003)*. Nevada, Las Vegas, 1: 874-879.
- Kuwayama, K., S. Kato, H. Seki, T. Yamakita and H. Itoh, 2003. Motion control for humanoid robots based on the concept learning. *Proceedings of the International Symposium on Micromechatronics and Human Science (MHS, 2003)*, pp: 259-263.
- Matsui, T., 2010. Optimal control model for reproducing human rising movements from chair and its effectiveness verification. *Proceedings of the IEEE International Conference on Robotics and Biomimetics (ROBIO)*, pp: 944-949.
- Millington, P.J., B.M. Myklebust and G.M. Shambes, 1992. Biomechanical analysis of the sit-to-stand motion in elderly persons. *Arch. Phys. Med. Rehab.*, 73: 609-617.
- Mistry, M., A. Murai, K. Yamane and J. Hodgins, 2010. Sit-to-stand task on a humanoid robot from human demonstration. *Proceedings of the 10th IEEE-RAS International Conference on Humanoid Robots (Humanoids)*, pp: 218-223.
- Mughal, A.M. and K. Iqbal, 2006a. A fuzzy biomechanical model for optimal control of sit-to-stand movement. *Proceedings of the IEEE International Conference on Engineering of Intelligent Systems*, pp: 1-6.
- Mughal, A.M. and K. Iqbal, 2006b. A fuzzy biomechanical model with H2 control system for sit-to-stand movement. *Proceedings of the American Control Conference*, pp: 3427-3432.
- Mughal, A.M. and K. Iqbal, 2008. Bipedal modeling and decoupled optimal control design of biomechanical sit-to-stand transfer. *Proceedings of the International Workshop on Robotic and Sensors Environments (ROSE, 2008)*, pp: 46-51.
- Pchelkin, S., A. Shiriaev, L. Freidovich, U. Mettin, S. Gusev and K. Woong, 2010. Natural sit-down and chair-rise motions for a humanoid robot. *Proceedings of the 49th IEEE Conference on Decision and Control (CDC, 2010)*, pp: 1136-1141.
- Prinz, R., S. Neville and N.J. Livingston, 2007. Development of a fuzzy-based sit-to-stand controller. *Proceedings of the Canadian Conference on Electrical and Computer Engineering (CCECE, 2007)*, pp: 1631-1634.
- Rasool, G., A.M. Mughal and K. Iqbal, 2010. Fuzzy biomechanical sit-to-stand movement with physiological feedback latencies. *Proceedings of the IEEE International Conference on Systems Man and Cybernetics (SMC, 2010)*, pp: 316-321.
- Riley, P.O., R. Popat and D.E. Krebs, 1995. Momentum analysis of sitback failures in sit-to-stand trials. *Proceedings of the IEEE 17th Annual Conference on Engineering in Medicine and Biology Society*, 2: 1283-1284.
- Sakai, M., Y. Tomoto, M. Kanoh, T. Nakamura and H. Itoh, 2010. Acquisition of robot control rules by evolving MDDs. *Proceedings of the IEEE International Conference on Fuzzy Systems (FUZZ)*, pp: 1-7.
- Strausser, K.A. and H. Kazerooni, 2011. The development and testing of a human machine interface for a mobile medical exoskeleton. *Proceedings of the IEEE/RSJ International Conference on Intelligent Robots and Systems (IROS)*, pp: 4911-4916.
- Sugisaka, M., 2007. A control method for soft robots based on artificial muscles. *Proceedings of the 4th IEEE International Conference on Mechatronics (ICM, 2007)*, pp: 1-3.
- Xue, G. and D.H. Ballard, 2006. Motor synergies for coordinated movements in humanoids. *Proceedings of the IEEE/RSJ International Conference on Intelligent Robots and Systems*, pp: 3462-3467.