

Positioning Control of XY Table Using 2-DOF PID Controller

Ong Yee Teng^a, Chong Shin Horng^b and Hee Wai Keat

Centre of Excellence of Robotics & Automation (CERIA), Universiti Teknikal Malaysia Melaka
Hang Tuah Jaya, 76100 Durian Tunggal, Melaka, Malaysia.

^ajace.teng@gmail.com, ^bhorng@utem.edu.my

Keywords: Positioning control, Two-degree-of-freedom PID, XY table

Abstract. A two-degree-of-freedom (2-DOF) PID controller is designed for an AC servo ball screw driven XY table. XY table is widely used in manufacturing industry especially in CNC machineries. The most commonly used controller in industries is conventional PID controller. This controller has satisfactory performance, simple structure, and is one-degree-of-freedom (1DOF). Nonetheless, PID controller can only achieve either good set-point response or good disturbance response. This leads to introduction of 2-DOF PID controller which can achieve both good set-point response and disturbance response. In this project, 2-DOF PID is used for accurate tracking purpose. 2-DOF PID controller is designed using two-steps-tuning-method. Disturbance response is optimized by tuning parameters of K_P , T_i , and T_D using Ziegler-Nichols 2nd method, followed by optimization of set-point response by tuning of 2-DOF parameters, α and β . Tracking performance of 2-DOF PID controller is compared with conventional PI and 1-DOF PID. Maximum absolute error, sum of absolute error, and mean square error are analyzed for all tracking performance of compensated system. Result shows that tracking error compensation (set-point response) of 1-DOF PID controller is better than 2-DOF PID controller. However, this is due to tuning of α and β parameters in simulation in this project. α and β values should be tuned experimentally. Disturbance response of 1-DOF PID and 2-DOF PID are almost similar due to same K_P , T_i , and T_D values are used in both controllers.

Introduction

XY table has advantages of having cheap cost, large stroke, high availability and generality. Each axis of the XY table is linked to an AC servo motor through a ball screw mechanism. It consists of two-degree-of-freedom (2DOF) motion. Each positioning axis consists of a one-degree-of-freedom linear guide-way, a servo motor, a ball screw mechanism, and an encoder. XY table is realized by stacking two one-DOF axes together. Thus, modelling of plant in this project considers only one-axis performance.

Nonlinearities and uncertainties phenomena of the plant have been a major problem in point-to-point positioning system. Main nonlinearities in XY table are existence of friction and saturation of actuator and/or power amplifier. These nonlinearity causes steady-state error and slow transient response for the positioning output. Besides, they can also affect the stability of plant [1]. Nonlinear phenomena affect the positioning precision and tracking accuracy.

Over the centuries, many types of controllers had been introduced for motion control of XY Table. Amongst are conventional PID, time-optimal, sliding mode, auto-tuning, fuzzy logic, and neural network controllers. For controller with simple design like PID, it usually has low performance while a controller with good performance usually has complicated design process.

Various kinds of research had been done on 2DOF PID controllers. There are preceded-derivative PID, I-PD, and other types of 2DOF PID controllers. Araki and Taguchi had introduced five equivalent forms of 2DOF PID controllers [2]. They are the feedforward, feedback, set-point filter, filter and preceded-derivative, as well as component-separated type [1]. In their paper, preceded-derivative PID and I-PD controllers can be both derived from feedback type 2DOF PID controllers.

Multiple dominant multiple pole method for the tuning of 2DOF PI and PID controllers. However, this method assumes that multiple dominant pole is real and stable. There is also model-driven 2DOF PID control method. In this system, model of the plant is used as part of the controller. This controller has simple structure, easy tuning, high stability, and high robustness. M. Sugiura et al. proposed the method to obtain controller parameters of 2DOF PID from only mover mass, thrust constant, and desired cutoff frequency of the position control system [3]. Their design method proved to be robust for load variation and disturbance influences. It is also shown that by using this method, the transient performance has improved.

Two-Degree-Of-Freedom (2DOF) PID has been introduced to allow better performance despite simple controller structure. By having more than one tuning element, 2DOF PID enables good set-point response and disturbance response to be achieved simultaneously. In this project, a 2DOF PID controller is designed to improve the tracking performance of XY table. In this project, tracking positioning performance of compensated system is evaluated by three error features. They are maximum absolute error, sum of absolute error, and mean square error.

Mathematical Modeling and Controller Design

Open-loop model of plant is shown in Fig. 1. There is an inner feedback loop from the velocity output, $\omega(s)$ as this is a servo system. K_b is located in the feedback path as back emf constant. With an additional integrator that made system as Type 1 system, this is a second order system. Table 1 shows the nominal object parameters that are used in this project. The input command is voltage (V) and measured output is position in millimeters.

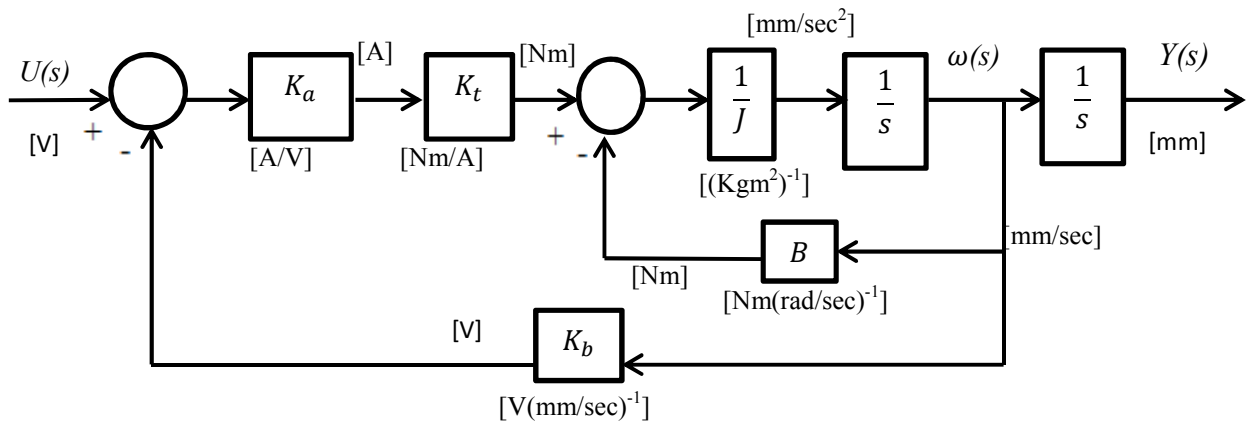

Fig. 1 Open-loop block diagram of plant.

From Fig. 1, the open-loop transfer function is:

$$\frac{Y(s)}{U(s)} = \frac{K_a K_t}{J s^2 + (B + K_b K_a K_t) s} \quad (1)$$

Table 1 Nominal Object Parameters.

Amplifier gain, K_a	15 A/V
Motor torque constant, K_t	0.64 Nm/A
Inertia of motor and table, J	$1.2846 \times 10^{-3} \text{ Kgm}^2$
Damping coefficient, B	$0.0001 \text{ Nm. (rad/sec)}^{-1}$
Back emf constant, K_b	$0.0234 \text{ V. (rad/sec)}^{-1}$

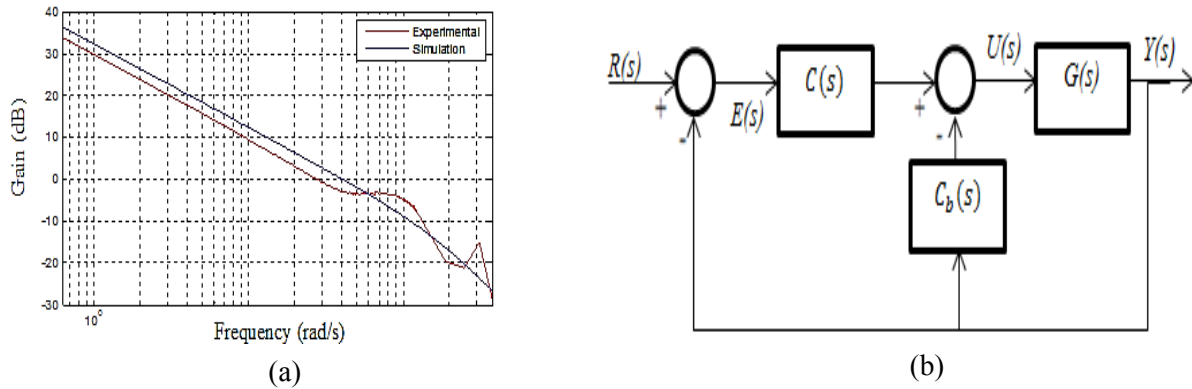

Fig. 2 (a) Magnitude plot of simulation and experiment, (b) Feedback type 2 DOF PID control system.

Fig. 2a shows magnitude plot of experiment and simulation model. Bandwidth or cut-off frequency is identified at 6.6 Hz or 41.47 rad/s. As can be seen clearly in Fig. 2a, the system cannot perform well at high frequency after it reaches cut-off frequency at 41.47 rad/s. Therefore, it is expected that the mechanism will vibrate at high frequency.

A 2-DOF PID controller contains two control elements, thus it has two independent closed-loop transfer functions [1]. Fig. 2b shows the block diagram of feedback type 2-DOF PID control system, $G(s)$ is the plant transfer function. This control system has two compensators. They are $C(s)$ in forward path and C_b in feedback path. $R(s)$ is the reference input in unit voltage while $Y(s)$ is the output displacement in unit millimeters. $E(s)$ is the error and $U(s)$ refers to the control signal generated by the controller compensators. Equations of controller equations for the compensators are shown in Eq. 2 and Eq. 3.

$$C(s) = K_p \left[(1 - \alpha) + \frac{1}{T_i s} + (1 - \beta) T_D D(s) s \right] \tag{2}$$

$$C_b(s) = K_p [\alpha + \beta T_D D(s) s] \tag{3}$$

where K_p is the proportional gain, T_i is the integral time, T_D is the derivative time, α is the portion of proportional gain that move to feedback path ($0 \leq \alpha \leq 1$), β is the portion of derivative that move to feedback path ($0 \leq \beta \leq 1$), and $D(s)$ refers to $\frac{s}{1 + \tau s}$ (τ is set as $\frac{T_D}{\delta}$, δ is normally set as 1000) [2].

Two-steps-tuning-method which is proposed by M. Araki & H. Taguchi is used [1]. Step 1 is to tune the first compensator, $C(s)$ to optimize disturbance response. This is done by adjusting the basic PID controller parameters ($K_p, T_i, \text{ and } T_D$). Step 2 is to tune the 2-DOF compensator parameters, α and β . Let $C(s)$ to be fixed, and set-point response is optimized by tuning the 2-DOF PID controller parameters (α and β). The values of controller parameters ($K_p, T_i, \text{ and } T_D$) are obtained using tuning table of classical method, Ziegler-Nichols 2nd method [4] and are shown in Table 2. By tuning method, the values of α and β values chosen are 0.2 and 0.6 respectively. The effectiveness of 2DOF PID controller in tracking control is validated by examining sinusoidal inputs of different frequency and amplitude in experiments and simulation.

Table 2 Controller parameters

Controller	K_p	T_i	T_D	α	β
PI	4.5455	0.04	-	-	-
1 DOF PID	5.8824	0.024	0.006	-	-
2 DOF PID	5.8824	0.024	0.006	0.2	0.6

Performance Evaluation

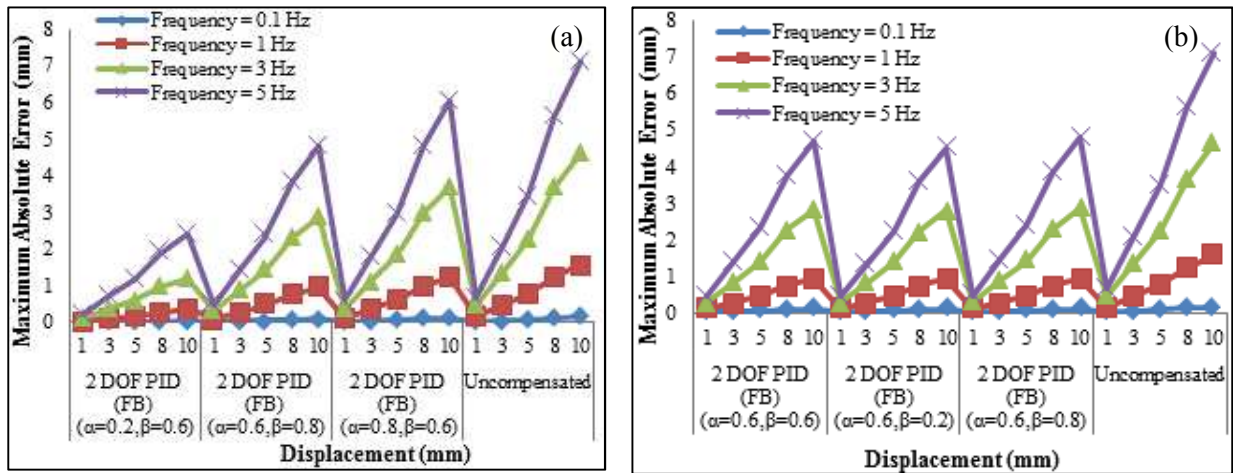

Fig. 3 Maximum absolute error Analysis for different values of (a) alpha, α and (b) beta, β .

Fig. 3a shows that maximum absolute error increases with frequency and displacement. As α decreases, maximum absolute error decreases when all other parameters (K_p, T_i, T_D , and β) are kept constant. Role of α is percentage of proportional gain that is moved from forward path to the feedback path. It can be inferred that when α is decreased, more proportional is kept in forward path, leads to higher amplitude of control signal. This then generates higher velocity to drive the motor that will reduce the tracking error. Fig. 3b shows that when β parameter is decreased, tracking error is not affected. Although decreasing β value will increase amplitude of control signal, velocity of the motor is not affected much.

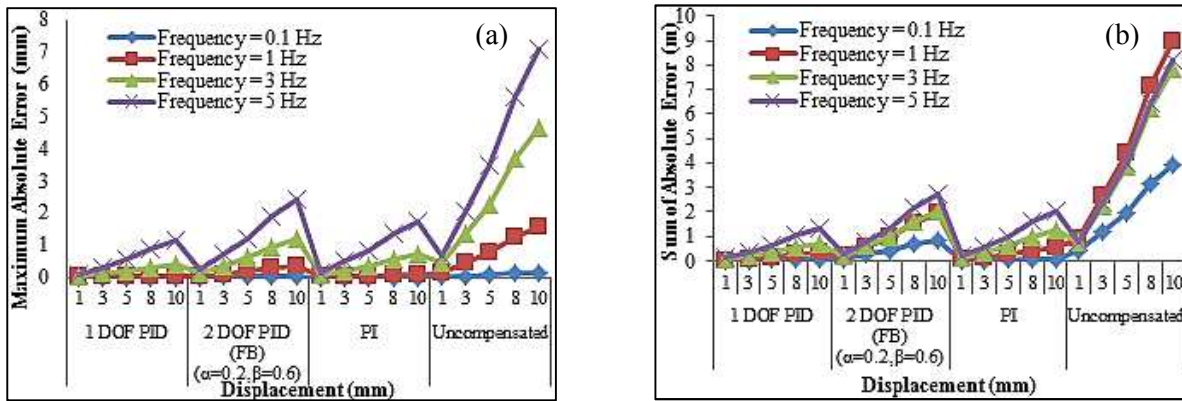

Fig. 4 (a) Maximum Absolute Error Analysis and (b) Sum of Absolute Error Analysis for 1DOF PID, 2DOF PID, and PI compensated system.

Fig. 4a shows that regardless of types of compensation, maximum absolute error increases with displacement and frequencies. It is also shown that 1-DOF PID has the lowest error. This is due to lower proportional gain in forward path of the 2-DOF PID compensation. In this case, the 2-DOF PID parameters of α and β were tuned in simulation only. To improve the performance of 2-DOF PID, α and β values should be tuned experimentally when actual disturbances are present. Fig. 4b also shows 1-DOF PID has lowest tracking error. In fact, this is also due to the nature of the uncompensated plant. It is found that tracking error that happens when system is uncompensated is due to initial phase lag of 0.033 seconds. This phase lag is caused by the offset of hardware mechanism. Simple controllers such as PID cannot compensate for this time delay. Nonetheless, both 1-DOF PID and 2-DOF PID have proportional gain that will force the motor to turn faster with higher velocity. The effect of high proportional gain is obvious during the first cycle. It induces a

high overshoot. Nevertheless, this overshoot has enables rotation of motor to compensate for the time delay. Thus, 1-DOF PID with higher proportional gain in forward path has lower tracking error.

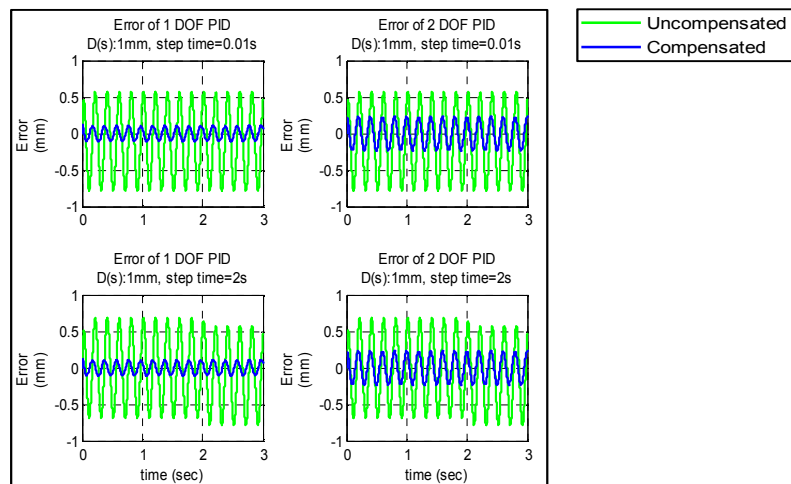

Fig. 5 Tracking error of 1-DOF PID and 2-DOF PID for 5 Hz and 1mm when step disturbance is added (displacement = 1mm, $t = 0.01$ and 2 sec).

Fig. 5 shows tracking error when step disturbance is added to the system. Even though step time changes, 1-DOF PID and 2-DOF PID compensated system show no big change in compensation of tracking error. Fig. 10 shows the tracking error of 1-DOF PID and 2-DOF PID when sine wave disturbance force is added to the system. Tracking error compensation of 1-DOF PID and 2-DOF PID compensated system is not affected much. In terms of disturbance response, the 1-DOF PID and 2-DOF PID have almost similar performance. This is due to the second tuning element (second compensator) that is introduced in 2-DOF PID is effective for tuning of set-point response. This can be referred to as in its control system closed loop transfer function.

Conclusion

Overall set-point tracking performance of 1-DOF PID seems to be better than 2-DOF PID controller for this system. 1-DOF PID controller has showed very impressive compensation of steady-state tracking error for different frequencies and amplitude from analysis of maximum absolute error, sum of absolute error, and mean square error. Since tracking error of uncompensated system happens because of phase delay that caused by offset, higher proportional gain of 1-DOF PID compensated system makes the system to move faster during first cycle. Thus, tracking error during steady-state can be effectively reduced. In this project, α and β parameters are tuned in simulation. To improve the performance of 2-DOF PID, α and β parameters need to be tuned experimentally. In terms of disturbance response, both 1-DOF PID and 2-DOF PID shows no big change in compensation of tracking error when amplitudes, step time, or frequency of disturbances changes. This is due to referring to the closed loop transfer function of control system, the disturbance response of 1-DOF PID and 2-DOF PID are same.

References

- [1] M. Araki, H. Taguchi, Two-degree-of-freedom PID controllers, *Int. J. Control Autom. Syst.* 1 (2003) 401-411.
- [2] H. Taguchi, M. Araki, "Optimal Tuning of Two-Degree-of-Freedom PD Controllers", *The 4th Asian Control Conference*, pp. 268-273, Sept 2002.
- [3] S. Yamamoto, H. Hirahara, A. Tanaka, T. Ara, "Simple Robust Design of Two-Degree-of-Freedom PID controller for Tracking Drives of Linear Servo Motors", *15th International Conference on Electrical Machines and Systems (ICEMS)*, pp. 1-6, Oct 2012.
- [4] A. O'Dwyer, *Handbook of PI and PID Controller Tuning Rules*, 3rd ed., Boston: Imperial College Press, London, 2005.