

A REVIEW ON THE INTERACTION COMPONENT IN FORMULATING SUSTAINABLE SUPPLY CHAIN MANAGEMENT

¹Wan Hasrulnizam Wan Mahmood, ²Norhafiza Mohamed,

³Mohd Razali Muhamad, ⁴Muhamad Zaki Yusup

¹Sustainable and Responsive Manufacturing Research Group,
Faculty of Manufacturing Engineering, Universiti Teknikal Malaysia Melaka,
76100 Hang Tuah Jaya, Melaka, Malaysia

²Kolej Kemahiran Tinggi MARA Kuantan, Km 8, Jalan Gambang,
25150 Kuantan, Pahang, Malaysia

²Email: norhafiza@kktmkuantan.edu.my

ABSTRACT: *This paper proposes an interaction component in formulating Sustainable Supply Chain Management. Sustainable Supply Chain is one of the advance technology approaches that compete with a high productivity and less cost. In order to achieve the best performance on sustainability, the process of Supply Chain Management must accomplish with the management of industry. The process of Supply Chain Management includes five elements; planning, procurement, production, delivery and response level. All these processes have their own interaction on manufacturing. The interaction framework presented in this paper could be used by manufacturers and researchers to gain more thoughtful on the process of supply chain management.*

KEYWORDS: sustainable, supply chain management, interaction component, process management

1.0 INTRODUCTION

Supply chain management (SCM) has had a substantial impact as a facilitator of globalisation of the world economy [1]. SCM represents the most recent approach to the distribution arrangements, in which it tries to “capture” the “whole” supply chain by taking into consideration of the increased complexity of these arrangements. [2]. SCM is also defined as the management of the flow of goods. It includes the movement and storage of raw materials, the work-in-process inventory and the finished goods from point of origin to point of consumption. Interconnected or interlinked networks, channels and node businesses are involved in the provision of products and services required by the end customers in a supply chain [3]. In an advanced technology nowadays, there is a need for the involvement of sustainability in SCM. The intersection of SCM and sustainability could be understood from three different approaches; 1) an integrated strategy, where sustainability is fully consistent with SCM, 2) an alignment strategy, in which sustainability is complementary to the traditional, where SCM focuses on cost and service, and 3) a replacement strategy, in which the traditional SCM concepts are replaced by an alternative approach to cope with the environmental and social aspects [1]. The economic, social and environmental dimensions are also recognised as the “three pillars of sustainability” [4]. All the three pillars discussed were interrelated to the effects of the process in developing a sustainable SCM. The design and management of activities across the supply chain has been focused solely on increasing economic gains [5]. The objective of this paper is to investigate the potential input and output of the components in SCM. The connection of component would affect the “three pillars of sustainability”.

2.0 LITERATURE REVIEW

Process of Sustainable Supply Chain Management

SCM is the combination of art and science that focuses on improving the means of finding the raw components in manufacturing a product or providing services, and later, delivering it to the customers. The five basic components of SCM are known as the planning, procurement, production,

delivery and response level [6]. Figure 1 shows the connection of components in SCM. To develop a sustainable supply chain management, there are three inputs of processes that interact. The inputs are planning, response level and procurement. At the planning stage, the process becomes an input of production, procurement and delivery. The second process is the procurement, in which it is highly dependent on planning and production rate. These processes drive to production. Production requires the planning and procurement processes as inputs to deliver the product to customers. Sometimes, when there is response from customer, production and delivery needs to be reflected. The relationship between those processes is highlighted in the complete cycle of Sustainable Supply Chain Management. Planning is one of the processes in SCM that involves customer’s demand and resources. For this connection, the components give a big impact to make sure that movement of material and storage under control. Time is also important in SCM management. Integrated decisions with different time units may imply significant savings for a company [7]. A few models have been identified as to strengthen the management of SCM. The supply chain has been identified as to cover a full range of activities; from the earliest level of incoming raw materials through the internal processes in an industry and on to the outgoing products through the distribution and marketing channels [8]. The material was controlled by procurement to make sure all the sources are under organized. It is also crucial to state the payment method clearly at procurement stage to prevent losses. The second element is shop floor inventory, the input of the element are production and responsive level. Three items are involved in the production process; operation activities, testing and packaging. The operation activities are based on procurement process. In place of the connection of process in SCM, work in process has higher effects on reducing lead times. In finished goods element, there are two items effects the process. The items are delivery and responsive level. At the delivery process, planning becomes an input to make sure the entire products deliver to customer on time with good conditions. The outputs of delivery process are invoice

system, carrier and warehouse network. Responsive level is the most critical level because it would cause a major impact on the process. Shop Floor Inventory would be affected if there is any claimed on return back product and at the same time would affect the production process. The solutions of this problem are flexible and responsive network in this process. For the connection of process in SCM to work in process inventory, it is more effects on reducing lead times. For example, He et al. [9] assumed lead time to be stochastic and measurable; [10] described lead times as a fuzzy set; and [11] compared the performances of a multiple source supply system with different types of lead times that were constant, stochastic, and exogenous.

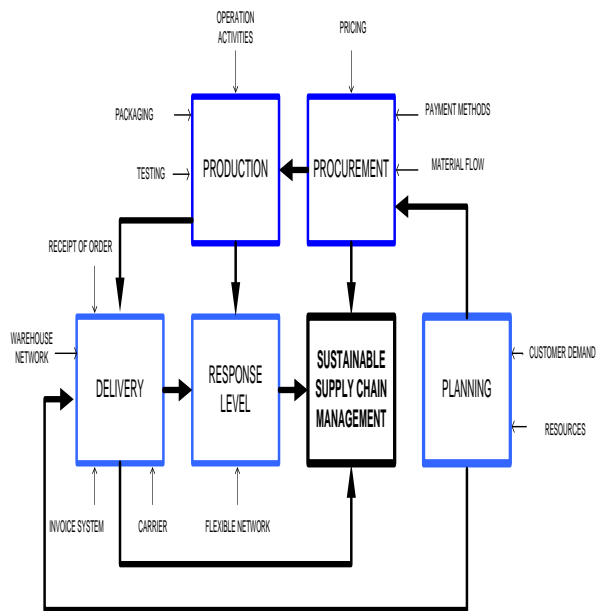

Figure 1: Sustainable Supply Chain Management Process Planning

Planning is one of the strategic portions of Sustainable SCM. In meeting their customer's demands Companies need a strategy for managing all the resources that transformed into a product or service that meets their customer demand. A big concern on Sustainable SCM planning through developing a set of metrics to monitor the supply chain could result in efficiency, less cost and delivery high quality and valuable to customers. The planner needs to focus on customer demand of product to schedule all the related process. In order, to achieve sustainability, the schedule should optimize the resources that focus on the material, manpower, machine and methods. The important aspect that needs to improve in manpower is developing their talent skills. Employees should shift their focus on talent as a critical resource for sustainability. Specialization needs to enhance the skill and advance technology. From high unemployment and stress social systems to companies that are struggle to grow because they could not find people with the skills they need, ensuring the sustainability of the world's workforce is at the forefront of business minds. Companies that implement

sustainability should connect people to the jobs and improve a person's employability that could build communities, countries and the lives of individuals. At the end of implementation of manpower sustainability, everyone has a responsibility to come together collectively to ensure the talent sustainability of countries and economies. The important aspect in manpower is if unemployed become unemployable, country lose the ability to build sustainable economic. For material planning and sources in sustainable, three items was focus. The materials should from natural resource, have a product life cycle and the companies should have waste management policies. Sustainability in materials would give effects in maintaining natural resources form the environment to the quality of life and could be used in next generation. The materials also should be focused on product life cycle which related to use and reuse of materials in the most productive and sustainable way to produce life cycle material. The current methodology which are 3R's; reduce, reuse and recycle should extend and include another R(s); recover, redesign, and remanufacture [5]. Supply chain outputs would be recycled, based on the market, suitability, and quality of the materials to be recycled [12]. The next elements in resources are method and machine. For implementation of an efficient manufacturing process that contribute to strong care of keeping environmental and social needs, it need to focus on placing modern machining processes and technology methods. For this implementation, it is important to test and predict manufacturing process within a virtual manufacturing processing and thus a strong contributor to the realisation of sustainable manufacturing process. Due to the similarity of parts and proximity of work stations, a cellular manufacturing layout has a lot of advantages, such as managing material flow easily, reduction in lead time, and reduction in setup time [13].

Procurement

Procurement is the next component, where companies begin to choose suppliers to deliver their goods and services. Therefore, it is necessary for supply chain managers to develop a set of pricing, delivery and payment process with the suppliers and also to create metrics for monitoring and improving the relationships. Consequently, the SCM managers would be able to put together processes for managing their inventory of goods and services, including receiving and verifying shipments, transferring them to the manufacturing facilities and authorizing supplier payments. The material flow is an element that needs to be concentrated in implementation of sustainable production. The flow of materials and inventory management systems are important to synchronise production with the customer's demand. This implementation would lead to sustainable results with shorter lead time and reduced cost. Implementation of Kaizen and 5S systems would result in sustainable flow production, supplier forecasts and lean manufacturing whereas inventory tools such as KANBAN, Value Stream Mapping and Pull Systems are widely used in maintaining sustainability.

Production

The third element is production, which also known as the manufacturing level. Supply chain managers schedule

activities are necessary for producing, testing, packaging and preparing the products for delivery. This is the most metric-intensive portion of the supply chain—one where companies are able to measure quality levels, production output and worker productivity. Production is the heart of any manufacturing company. This element emphasizes on three aspects; beginning with the input, the process of the raw material and its transformation into a product. The important aspects such as manpower, machine and material was scheduled in planning components. To remain sustainable, companies need to adopt methodologies such as Lean Manufacturing to reduce waste, and Six Sigma to increase quality. The simultaneous deployment of lean practices may improve business performance while creating economic, social, and environmental benefits. In the literature, there are several research studies that focused on green and lean approaches, but they treat them separately [14]. By implementing this program, companies would undergo increasing customer demand customer satisfaction and market share. So, one of the goal of SCM is customer satisfaction which could only be achieved through fulfilment of customer requirements related to quality, cost, (delivery) time, and flexibility is achieved [15].

Delivery

Delivery, which many SCM insiders refer to as logistics, refers to the acts of the companies in coordinating the receipt of orders from the customers, developing a network of warehouses, deciding on carriers to deliver products to customers and setting up an invoice system to receive payments. Sustainable in delivery system includes planning, implementing, and controlling an efficient and effective forward and reverse flow of goods storage, services, and related information between the manufacturer's company and customers in order to meet the customers' requirement. Sustainable focuses on reducing waste by implementing software in logistic automation. The software helps the supply chain industry in automated the workflow as well as management of the system. The implementation would affect the logistic network, information needs, transportation, sound inventory management, warehousing, material handling and packaging. Sustainable logistic management helps companies to reduce expenses and enhance customer service. Nevertheless, there are a few aspects that need to be considered in sustaining the delivery process; 1) selecting capable vendors that could provide necessary transportation facilities, 2) choosing the most effective routes for transportation, 3) discovering the most competent delivery method and 4) integrating appropriate software and Information Technology resources to proficiently handle related process.

Responsive Level

The responsive level, which is the last element, is perceived as the most problematic part of the supply chain for most companies. Supply chain planners have to create a responsive and flexible network to receive defective and excess products returned by the customers and to assist customers who are facing problems with the delivered products. Different types of flexibilities such as new product introduction, volume flexibility and product mix flexibility play the role of strategic importance in dealing with turbulent markets [16]. Sustainable manufacturing system would ensure that the production line is not affected by the returned products. Flexible manufacturing system (FMS) was used to allow the system to react in case of changes, whether predicted or unpredicted. The main advantages of an FMS are its high flexibility in managing manufacturing resources such as time and effort spent in manufacturing a new product. FMS promotes rapid turnaround, high quality, low inventory and labour cost that led to its adoption in the most recent manufacturing system in the industrial sectors [17].

3.0 CONCLUSION

A common theme in this discussion regarding the future of supply chain management is the interaction of those processes in achieving sustainability of SCM. Future supply chains would be challenged by the high technology with advance approach to improve efficiency in the use of resources, the material storage and movement, and the product design which are the main aspects in sustainability. The best solution would be to maximize the usage of process to develop successful flows of goods in the industry. Therefore, this paper developed the framework in improve SCM by interact five components of the process and discuss the input and output between components mentioned. From the interaction of SCM process, there are a lot of aspects that influences the process of produce the product. The effects might be dropping the performance of an organization. All important elements which are missing in the current process of manufacturing process may be directly incorporated in the framework, for example man, material, machine and environment. By making use of the suggested framework, production line may achieve the objective of SCM for dealing with the varying situations under which it may have to operate. Without a doubt, a sustainable SCM offers the best possible solution in managing the input of the process to the output of the product. For future research, a survey could be conducted to recognize the knowledge in application of SCM in manufacturing industry.

ACKNOWLEDGEMENTS

This research was co-funded by Universiti Teknikal Malaysia Melaka (UTeM) under PJP Research Grant PJP/2013/FKP (11A)/S01201.

REFERENCES

- 1 Á. Halldórsson, H. Kotzab, T. Skjøtt-Larsen, Supply chain management on the crossroad to sustainability: a blessing or a curse?, *Logistics Research*, **1** (2), 83–94, 2009.
- 2 G. Gripsrud, M. Jahre, and G. Persson, Supply chain management – back to the future?,” *International Journal of Physical Distribution & Logistics Management*, **36**(8),643–659, 2006.
- 3 C. M. Harland, Supply Chain Management, Purchasing and Supply Management, Logistics, Vertical Integration, Materials Management and Supply Chain Dynamics., *Blackwell Encyclopedic Dictionary of Operations Management*, 1996.
- 4 S. J. Hutchins MJ, An exploration of measures of social sustainability and their application to supply chain decisions, *J Clean Prod*, **16**, 1688–1698, 2008.
- 5 M. Shuaib, H. Metta, T. Lu, F. Badurdeen, I. S. Jawahir, and T. Goldsby, Advances in Sustainable Manufacturing, 345–350, 2011.
- 6 T. Wailgum, Supply Chain Management Definition and Solutions, 2007.
- 7 A. Q. N. c Maria Isabel Gomes Salema a, Ana Paula Barbosa-Povoa b, Simultaneous design and planning of supply chains with reverse flows.pdf,336–349, 2009.
- 8 S. A. Hossain and Y. Ouzrout, Trust model simulation for supply chain management, *2012 15th International Conference on Computer and Information Technology (ICCIT)*, 376–383, 2012.
- 9 H. J. He XJ, Xu X, The effect of lead-time on the supply chain: the mean versus the variance, *International Journal of Information Technology & Decision Making*, **10**(01), 175, 2011.
- 10 W. X. Handfield R, Warsing D, Inventory policies in a fuzzy uncertain supply chain environment, *European Journal of Operational Research*, **197** (2), 609, 2009.
- 11 Z. P. Song JS, Inventories with multiple supply sources and networks of queues with overflow bypasses, *Management Science*, **55**(3), 362, 2009.
- 12 B. M. Beamon, Sustainability and the Future of Supply Chain Management,**4**(1), 4–18, 2008.
- 13 K.-L. Mak, J. Ma, and W. Su, Production scheduling for virtual cellular manufacturing systems with workforce constraints using a hybrid algorithm, *2010 Sixth International Conference on Natural Computation*, no. Icnc, 4445–4449, 2010.
- 14 V. C.-M. Susana G. Azevedo, Helena Carvalho, Susana Duarte, Influence of Green and Lean Upstream Supply Chain.pdf, IEEE TRANSACTIONS ON ENGINEERINGMANAGEMENT, **59**(4),753–765.
- 15 K. Rashid, Business excellence through total supply chain quality management, *Asian Journal on Quality*, **13**(3), 309–324, 2012.
- 16 V. Singh and V. P. Agrawal, Structural modelling and integrative analysis of manufacturing systems using graph theoretic approach, *Journal of Manufacturing Technology Management*, **19**(7), 844–870, 2008.
- 17 M. Nor, A. Khalid, U. K. Yusof, and M. Sabudin, Solving Flexible Manufacturing System Distributed Scheduling Problem Subject to Maintenance Using Harmony Search Algorithm, *2012 4th Conference on Data Mining and Optimization (DMO)*, 2–4, 2012.