

Modelling and Analysis of All Terrain Vehicle (ATV) using System Identification for Yaw Stability

F.A. Azis^{1, a}, M.S.M Aras^{1, b}, M.Z.A. Rashid^{1, c}, K.S. Khamis^{1, d}, O.A.A. Ghani^{1, e},
M.Nur. Othman^{2, f}.

¹Faculty of Electrical Engineering, Universiti Teknikal Malaysia Melaka, Hang Tuah Jaya, 76100 Durian Tunggal, Melaka, Malaysia

²Faculty of Technology Engineering, Universiti Teknikal Malaysia Melaka, Hang Tuah Jaya, 76100 Durian Tunggal, Melaka, Malaysia

^afadilah@utem.edu.my, ^bshahrieel@utem.edu.my, ^czamzuri@utem.edu.my, ^drule_frenzy@yahoo.com, ^ealiffviolin91@yahoo.com, ^fmuhammad.nur@utem.edu.my

Keywords: All-terrain vehicle, System identification step response approach, Yaw stability, Inertial measurement unit sensor.

Abstract. This paper presents the modelling and analysis of path-following planning motion of an All-Terrain Vehicle (ATV) using system identification technique in term of yaw stability. The modelling is based on the single track and established by using Newtonian equation motion. Mathematical modelling is constructed in form of state space equation with the parameters used are measured through physical measurement of prototype ATV. Based on this model selection, the open loop system is simulated and the result will be validated by using system identification. Inertial Measurement Unit (IMU) sensor is used to collect and measure the data for the path-following planning. The analysis results for yaw stability of prototype ATV are validated by system identification method with step response approach. Both of the simulated and measured data is compared and the data is estimated to get the best fit for yaw estimation by using complimentary filter technique. From the result, the best fit for yaw estimation is 91.96% and considered as stabilized at steering angle 45° .

Introduction

Nowadays, the usage of All Terrain Vehicle (ATV) gives much more benefit to the people in agriculture and industrial industry due to their field work was designed and dedicated to huge drivability on irregular ground track as well as on paved road. However, according to [1], a yearly census was conducted on the death of ATV riders, including deaths on public roads and it found that the accident occurs because of two factors; the recklessness of the user themselves and the problem with its stability when dealing with the road or track conditions when lost to steering control. Thus, this project is significant for modelling and analysis the ATV known as a quad bike. As ATV performance is keep improving year by year, the design process is requires better knowledge of their behavior. One of the methods to find this knowledge is through mathematical modeling. In this project, the modelling is based on the single track model [2].

Generally, the ATV has four-wheeler, but from the single track model, the ATV is considered as two-wheeler which is the left and right tire characteristics have an equal characteristics. In addition, the single track modelling is only considered a linear behavior of vehicle model whereby the roll of body is ignored due to the linear behavior. In other hand, to model the non-linear behavior, the new modeling approach is needed [3 -5]. Mathematical modeling in form of state-space is constructed and all parameters of the state-space are measured through the physical measurement of prototype of ATV. Open loop simulation is carried out to get the normal stability of ATV in term of yawing (steering control) and pitching moment. The maneuvers test such as lane change course and climb slope test are selected in order to analyze and validate the result of the simulated, measured and estimation stability of ATV. For simplicity, the combination of two unit sensors; accelerometer and

gyroscopes or known as Inertia Measurement Unit (IMU) is selected for data collection and however this sensor produced noise and disturbance [6].

All-Terrain Vehicle. In paper [7], the single track model also known as “bicycle model” was used to derive the mathematical modeling of the ATV. Moreover, in order to analyze the movement of prototype ATV in the lane change course test, the sensor that are going to use is IMU sensor as an estimation which is will be verified with the simulation of open loop simulation.

However, the sensor will produce raw data unit, hence, the conversion data and filtering need to do first by using the complimentary filter [8]. Then, the technique of system identification with a step response approach was used as proposed in paper [9]. This was because the input and output of prototype ATV can be measured by doing an experiment. Fig. 1 shows the overview of ATV such as suspension, tire, handlebar (steering) and rider display important roles in order to achieve the dynamic stability of the ATV when handling it.



Fig. 1 ATV Overview

Mathematical Modeling of ATV

The single track model represents the left and right tire characteristics have an equal tire characteristic of a two-wheel in plane vehicle. Below are the derivation based on the bicycle model as shown in Fig. 2 [4]:

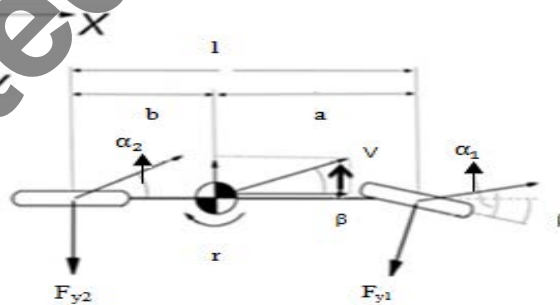

Fig. 2 bicycle” model [4]

The equation motion of the model:

$$m(\dot{v} + ur) = F_{y1} + F_{y2} \tag{1}$$

$$I\dot{r} = aF_{y1} - bF_{y2} \tag{2}$$

The force acting on tire:

$$F_{y1} = C_1\alpha_1 \tag{3}$$

$$F_{y2} = C_2\alpha_2 \tag{4}$$

The state space model can be written:

$$\dot{x} = Ax + Bu$$

$$y = Cx + Du$$

Whereby;

$$x = \begin{bmatrix} v \\ r \end{bmatrix}, \quad y = \begin{bmatrix} \alpha \\ r \end{bmatrix}, \quad u = \delta$$

And

$$A = - \begin{bmatrix} \frac{C_1 + C_2}{\mu} & u + \frac{aC_1 - bC_2}{\mu} \\ \frac{aC_1 - bC_2}{l} & \frac{a^2C_1 + b^2C_2}{ul} \end{bmatrix} \quad B = \begin{bmatrix} \frac{C_1}{m} \\ \frac{1}{l} \end{bmatrix}$$

$$C = - \begin{bmatrix} \frac{C_1 + C_2}{\mu} & \frac{aC_1 - bC_2}{\mu} \\ 0 & -1 \end{bmatrix} \quad D = \begin{bmatrix} \frac{C_1}{m} \\ 0 \end{bmatrix}$$

Where

C_1	Stiffness tire front	b	Distance of rear axle to center gravity
C_2	Stiffness tire rear	L	Length of wheelbase
β	Side slip angle	F_{y1}	Tire force front
α	Acceleration	F_{y2}	Tire force rear
δ	Angle steering	u	Velocity forward
a	Distance of front axle to Centre gravity	r	Gyro rate
		m	Mass

IMU and Complimentary Filter

IMU sensor was used as to measure and estimate the yawing stability through the analysis of the movement of the ATV according to lane change course self-obstacle avoidance. When dealing with the IMU sensor, the raw data unit is needed to normalized using arc tan function before being filtered. Thus, below are the conversion and normalization of sensor IMU with the complimentary filter:

Normalization of IMU;

$$\text{Pitching} = \arctan \frac{X}{\sqrt{Y^2 + Z^2}} \quad (8)$$

$$\text{Rolling} = \arctan \frac{Y}{\sqrt{X^2 + Z^2}} \quad (9)$$

$$\text{Yawing} = \arctan \frac{Z}{\sqrt{X^2 + Y^2}} \quad (10)$$

Complimentary filter method;

$$\text{Angle} = 0.98 (\text{angle} + \text{data of gyro} * dt) + 0.02 (\text{data of accelerometer}) \quad (11)$$

Simulation Result

The simulation of open loop system of state-space model was simulated and the result of simulation is shown in equation (12). Fig. 3 shows the block diagram of the open loop system.

$$A = - \begin{vmatrix} 8.99 & 1.246 \\ 86.41 & 28.75 \end{vmatrix} \quad B = \begin{vmatrix} 3.32 \\ 75.44 \end{vmatrix} \quad C = - \begin{vmatrix} 8.99 & 0.6676 \\ 0 & -1 \end{vmatrix} \quad D = \begin{vmatrix} 3.316 \\ 0 \end{vmatrix} \quad (12)$$

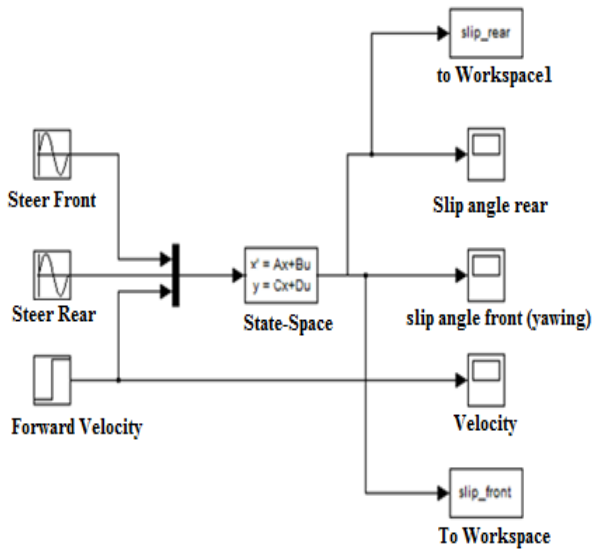

Fig. 3 Block diagram of open loop system.

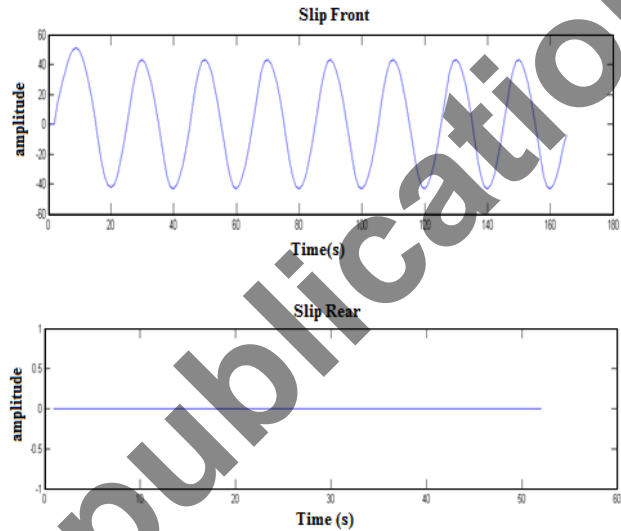

Fig. 4 Slip front and rear tire.

From the Fig. 4 shows that the output graphs have positive and negative of sine wave which are represented the yawing right and left. This simulated result of yawing is show the normal steering control at an angle 45° whereas shows the stabilization of ATV on regular surface. However, there is no slip on rear tire because the prototype ATV is only considered as steered at front wheel only.

Experimental Result.

Point A and D. At point A, the servo motor steer to 45° (right) from 90° (middle position). This, resulted the graph gradually increase which indicates as yawing right. Secondly, Point D, the servo motor steer to 135° (left) from 90° (middle position). This resulted the graph gradually decrease which indicates as yawing left as shown in Figure 5.

Point B and E. At peak of the graph for both positive and negative region, shows that the servo motor is counter-steer back after make a turning right (point A) and turning left (point D) to 90° (middle position) after the prototype ATV is already pass through the block 1 and block 2 as shown in Figure 5. This is to ensure that the prototype ATV is keep moving on the track test.

Point Start, C and F. At this point, the graph shows remained stabilized as it is represents the movement of prototype ATV is in straight motion after turning point (A ,D) and at starting point whereby the servo motor is in the 90° (middle position) as shown in Fig. 5.

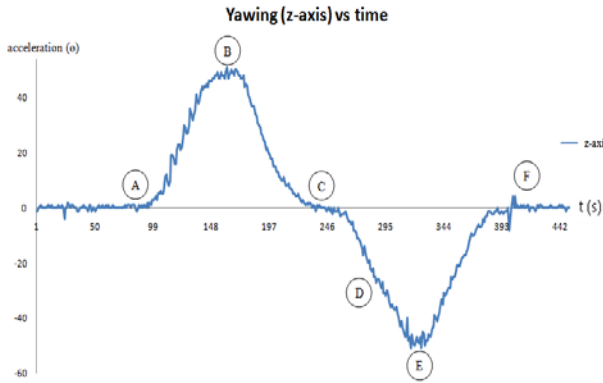

Fig. 5 A graph of yawing measured vs. time

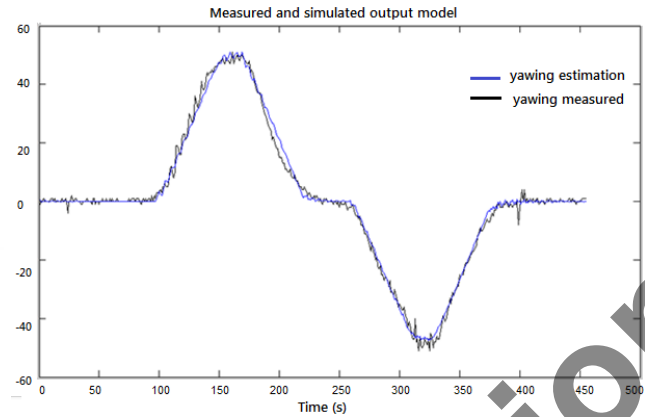

Fig. 6 Yawing estimation

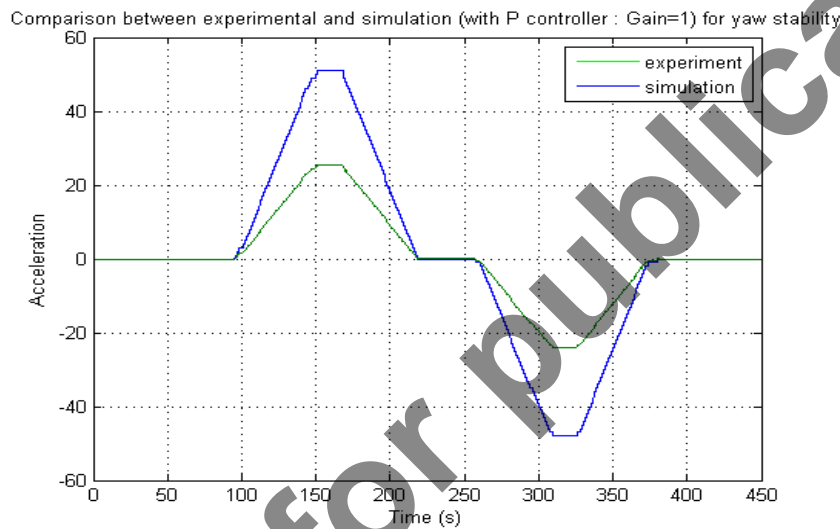

Fig. 7 Comparison between experimental and simulation for yaw stability

In Fig. 6, it shows that the best fits of yawing estimation are the selection of the 4th order of the state-space with percentage of 91.96%. From this validation, it know that there is no variation between the simulated and estimation yawing since the ATV steering is controlled and verified the simulated open whereby the ATV is at normal steer and stable at an angle 45° . Figure 7 shows the comparison between experimental results with simulation result with using simple proportional controller with Gain = 1 for yaw stability.

5.0 Conclusion

In practice, the estimating for yawing is not contributed in intricate problems. Firstly, the approximation introduced in the model structure above was valid for a rather narrow operation region only. The result analysis for yaw stability for prototype ATV are validated by system identification method; then the step response is approach whereby the simulated and measured data will be estimated and the best fit for yaw estimation was obtained by using complimentary filter technique. From the result, the best fit for yaw estimation is 91.96% and considered reach the stabilization at steering angle 45° . The stiffness varies with the environmental condition such as the surrounding temperature and the road surface conditions. Then, the estimation of the stiffness parameters relies heavily on the driving style. Thus, it becomes hard to estimate the stiffness of tire.

6.0 References

- [1] U.S. Consumer Product Safety Commission, annual report of ATV Technical report, CPSC annual report. Washington DC, U.S.A., 2006.
- [2] P.Barec, M.Maly, R.Vozenilek. Control System Of Vehicle Model With Four Wheels Steering (4WS). *International Scientific Meeting Motor Vehicles & Engines Kragujeva*, 2004.
- [3] D.Eduoard, Parameter Identification Of A Linear Single Track Model, traineeship report, Eindhoven University Of Technology, Eindhoven, 2011.
- [4] Aras, M.S.M, Abdullah S.S., Rashid, M.Z.A, Rahman A.A., Aziz M.A.A., Development and Modeling of underwater Remotely Operated Vehicle using System Identification for depth control, *Journal of Theoretical and Applied Information Technology*, Vol. 56, No 1, 2013.
- [5] M.S.M. Aras, S.S. Abdullah, A.A. Rahman, M.A.A. Aziz, "Thruster modeling for underwater vehicle using system identification method", *International Journal of Advanced Robotic Systems: Underwater Vehicles*, pp 1 -12, vol 10, 2013.
- [6] M. S. M. Aras, F. A. Azis, M. N. Othman, S. S. Abdullah, A Low Cost 4 DOF Remotely Operated Underwater Vehicle Integrated With IMU and Pressure Sensor. In: 4th International Conference on Underwater System Technology: Theory and Applications (USYS'12), Malaysia, pp 18-23, 2012.
- [7] Y, Yuanming, G, YuBin.Q. Analysis of vehicle handling and stability in frequency domain based on system identification method. WASE International on reference on Information Engineering, 2010.
- [8] Yanrui Geng, Ricardo Martins, Joao Sousa. Study of Inertial Measurement Unit Accuracy System. 2010 IEEE International Conference On Control and Automation Xiamen, China, 2010.
- [9] Eykoff, P. System Identification, Wiley-Interscience, 1974.