

# Investigation of Single Cart Gantry Crane System Performance using Scheduling Algorithm

M. S. Omar, H. I. Jaafar, R. Ghazali, S. H. Mohamad, K. A. M. Annuar

**Abstract**—This paper investigates the implementation of two types of scheduling algorithm to obtain the best performances of the Single Cart Gantry Crane System (GCS). In this research, Deadline Monotonic Priority Assignment (DMPA) and Earliest Deadline First (EDF) scheduling algorithm are chosen to be implemented. The main ideas of this approach is to find the schedule that more compatible and provide more stable result for the system. The Cart performances will be analyzed in term of Settling Time ( $T_s$ ) and Overshoot (OS). In this study, a simple PID controller that acts as a basic control structure is used. The application of TRUETIME kernel block also is implemented to be executed in a MATLAB environment. It has been demonstrated that implementation of these two algorithms will help this system to be more stabilized according to appropriate execution time.

**Index Terms**—Cart Gantry Crane System, Deadline Monotonic Priority Assignment, Earliest Deadline First, Truetime.

## I. INTRODUCTION

Safety issues are very important for Gantry Crane System (GCS). It is because GCS is involved in many of heavy work environment and need to be controlled precisely. Thus, it has the potential to cause the accidents and dangerous to others [1]. The main purpose of this paper is to focus on the single cart GCS where the positioning of the cart (trolley) is crucial to be controlled. Cart should be a precious part because of the effectiveness of the cart will reduce time for the loading work and effect the sways of the payload. The cart should move as fast as possible, but it should not make a huge impact on the oscillation of the payload [2-3]. Since this system is faced with real time operation, implementation of the real time scheduling algorithm is executed to study the effect of this algorithm to the cart system. A real time system is the one in which the correctness of the result that is not only depends on the logical correctness of the calculation, but also upon the time at which the result is made available. Real time system is divided into two (2) requirements, namely control system and temporal requirement. The control system requirement is covered in terms of transient response which are Settling Time ( $T_s$ ) and Overshoot (OS).

### Manuscript Received on January 2015.

**M. S. Omar**, Faculty of Electrical Engineering (FKE), Universiti Teknikal Malaysia Melaka (UTeM), Hang Tuah Jaya, 76100 Durian Tunggal, Malaysia.

**H. I. Jaafar**, Faculty of Electrical Engineering (FKE), Universiti Teknikal Malaysia Melaka (UTeM).

**R. Ghazali**, Faculty of Electrical Engineering (FKE), Universiti Teknikal Malaysia Melaka (UTeM).

**S. H. Mohamad**, Faculty of Engineering Technology (FTK), Universiti Teknikal Malaysia Melaka (UTeM).

**K. A. M. Annuar**, Faculty of Engineering Technology (FTK), Universiti Teknikal Malaysia Melaka (UTeM).

Then, the temporal requirement covered the part of the time the correct result is produced, processor speed, clock selection, computing resources, and controller sampling time.

Scheduling is an algorithm or technique modelling for ordering the use of the system resources. A means of predicting the worst case behavior of the system when the scheduling algorithm is applied. Scheduling assumption should be made first before the scheduling can be proceed and it is important, even for non real time system. In order to develop the cart GCS, the uses of the scheduling algorithm method such as Deadline Monotonic Priority Assignment (DMPA) and Earliest Deadline First (EDF) are chosen to be investigated in this study.

## II. SCHEDULING ALGORITHM

### A. Deadline Monotonic Priority Assignment (DMPA)

DMPA is the one that assigns the priorities in inverse order to their parameters. Each job should have assigned by the priority instant of time and the processor allocated to the requirement priority jobs. Without the loss, the task will be indexed to the priority in decreasing order. The DMPA derivation should have effected the loss of accuracy, but the performance guarantees can be obtained by using the concepts of augmentation. Various research of DMPA has been developed in many applications. In some research, it engaged the constant-time admission for DMPA task [4]. The new task can be feasible scheduled together with the currently running task by the decision of the admission control test. DMPA scheduling policies hardly depend on the deadline, shorter or longer the tasks, and the highest priority assigned in the system. In case the deadlines are less than periods, the DMPA scheduling policies are the right and perfect choice to be implemented as the scheduling algorithm. Its relevance because of the DMPA is supported by the real time scheduling system. From the previous study, researchers proposed the improvement of the priority assignment for global fixed priority pre-emptive scheduling in multiprocessor real-time systems [5]. Formally, DMPA is relatively poor in performance in microprocessor case. But, for ordering independent synchronous task with the deadline that less or equal to the period, Deadline Monotonic Priority Ordering (DMPO) is an optimal scheduling. Normally, the scheduling test has the difficulties in their time prediction and pseudo-polynomial complexity. It required the priority to be sorted decreasing order to schedule the system due to this complexity and larger systems. By the schedule under DMPA scheduling algorithm load test, it always less pessimistic than the hyperbolic bound and the load test will perform a clear accuracy improvement, and detect more schedulable task. This test does the clear prove about the ability of the DMPA

scheduling. In [6], the issue regarding on the application of Real-Time scheduling techniques (RT scheduling technique) is discussed. The approach has been separated into global scheduling and partitioned scheduling where global scheduling usually can stored same number highest priority task and in the same global queue. As for the partitioned scheduling, it has the advantage in partitioned the task after the uniprocessor being reduced. Some comparison has been made between DMPA and EDF scheduling algorithm [7]. There are some advantages and disadvantages of these two approaches. The EDF algorithm known as the optimal schedulability on uniprocessor and the DMPA algorithm known as the real-time system that widely used. DMPA is a simpler implementation in operating system and has the lower run-time overhead, but the disadvantage of this algorithm is that it will reduce schedulability.

**B. Earliest Deadline First (EDF)**

Earliest Deadline First (EDF) is a real time scheduling algorithm that is used for the dynamic scheduling, task that required the queue of resource waiting and it always will selected and accentuate the earliest deadline compared to other deadline. EDF is normally optimal for any schedule and priority table. The priority assignment will reduce the computing priority table to overcome the single-critical problem that will appear after the single mode for optimal EDF. From the previous research of using EDF algorithms for the formation at Dynamic Time-critical Environment, it proposed about the challenge in decision making for the complex and dynamic multi-agent system [8]. The rescue simulation project is for testing coordination and cooperation mechanisms being the excellent test bed. On other quiet similar research, it applied mixed-criticality scheduling of sporadic task systems [9]. In this research, each task has multiple levels of scheduled of worst-case execution time estimations. It analyzed the processor speed up using the EDF-VD (EDF-Virtual Deadlines) because it will contribute to the field of effectiveness. In the field of the safety-critical systems, there several problems in term of scheduling and it increasing the trend of system towards integrating multiple function on the platform. EDF also has been implemented in a wireless communication system. From the research in [10], a Deadline, and Distortion (CD2) Aware Scheduling for Video Streams over Wireless, it related the CD2 with the EDF and Best Channel First (BCF). The main of this research is to achieve the performance gain by using knowledge of packet deadline, wireless channel conditions, and application information in systematic and unified ways in the world of multimedia scheduling.

**III. MODEL OF THE SYSTEM**

In this study, GCS will be used as a system to be investigated and Fig. 1 shows a schematic diagram of the system. Normally, two parameters which are desired position ( $x$ ) and payload oscillation ( $\theta$ ) will be considered in order to study on GCS behavior. However, only  $x$  is focused and  $\theta$  will be ignored. The GCS is modeled based on [11].

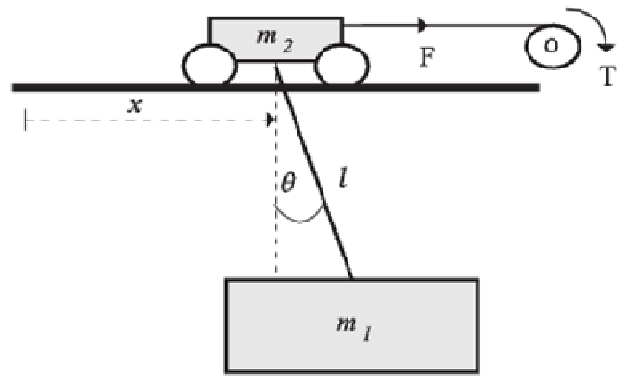

**Fig. 1: Schematic Diagram of GCS [11]**

A complete differential equation of the GCS model can be obtained as [12-13]:

$$V = \left[ \frac{RBr_P}{K_T z} + \frac{K_E z}{r_P} \right] + \left[ \frac{Rr_P}{K_T z} \right] (m_1 l) [\ddot{\theta} \cos \theta - \dot{\theta}^2 \sin \theta] + \left[ \frac{Rr_P}{K_T z} \right] (m_1 + m_2) \ddot{x} \tag{1}$$

$$m_1 l^2 \ddot{\theta} + m_1 l \ddot{x} \cos \theta + m_1 g l \sin \theta = 0 \tag{2}$$

The first analysis is considered by using a simple PID controller of a GCS process and intended to give a basic introduction to the TRUETIME simulation environment as shown in Fig. 2. The controller task is implemented in a TRUETIME kernel block that control the process. The scheduling algorithm will be implemented into the process by declaration call in MATLAB and TRUETIME kernel block parameter. The investigation of DMPA and EDF scheduling algorithm and will be analyzed to observe the effects of different input-output performances of GCS.

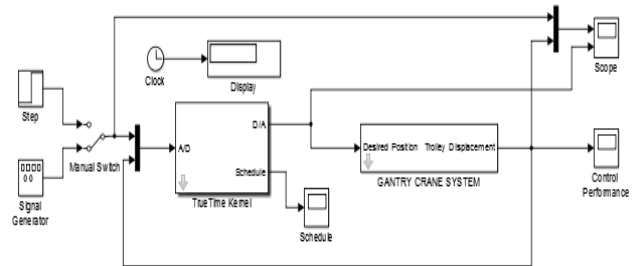

**Fig. 2: Single GCS through Simulation**

Fig. 3 is the block diagram inside the main block in Single GCS stated in Fig. 2. This block diagram will compress into the subsystem that represented as the main block for GCS.

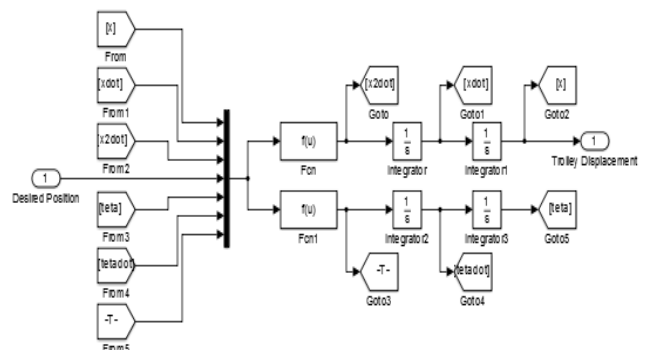

**Fig. 3: Block Diagram inside the Main Block of GCS**

Fig. 4 shows the parameter that has been implemented in the Single GCS system while Fig. 5 represents the TRUETIME kernel block. The function block parameter used as the input-output parameter set-up for the system to be simulated by right parameter. All the input-output was set up and declaration script for the scheduling is linked to this function block parameter.

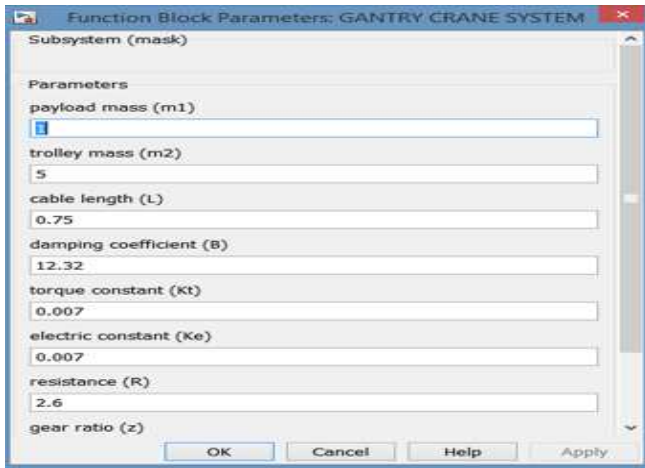

Fig. 4: Parameter of Single GCS

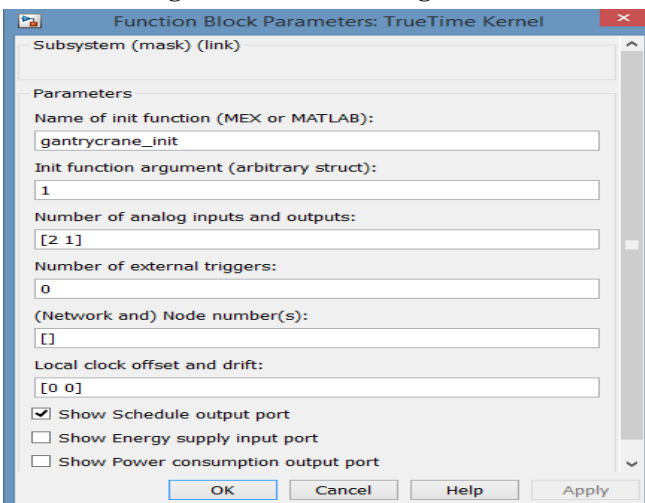

Fig. 5: Function Block Parameter for TRUETIME Kernel Block

#### IV. RESULTS AND DISCUSSION

In this section, there are four cases to be simulated in this configuration based on different execution time. The example pattern for the initial declaration codes are illustrated in Fig. 6 and Fig. 7 where purposely written for the changeable pattern example of execution time task declaration for the system. The initial period condition is set as 0.06 s and execution time is set at 0.02 s, 0.12 s, 0.40 s, and 0.90 s for both two algorithms (DMPA and EDF). For the deadline, it is set as equal to the period which is 0.06 s.

```

% Initialize True Time kernel
ttInitKernel('prioXXX');

% Task attributes
period = 0.06;
deadline = period;
    
```

Fig. 6: Initialize True Time Kernel and Task Attributes

% Execution time exectime = 0.02;	% Execution time exectime = 0.12;
(a)	(b)
% Execution time exectime = 0.40;	% Execution time exectime = 0.90;
(c)	(d)

Fig. 7: Execution time for each case

(a) Case 1 (b) Case 2 (c) Case 3 (d) Case 4

#### A. Simulation Result of DMPA

Fig. 8 shows the priority call for the DMPA and it was declared in ttInitKernel('prioDM'). This coding for priority DMPA called by the TRUETIME kernel block.

```

% Initialize True Time kernel
ttInitKernel('prioDM');

% Task attributes
period = 0.06;
deadline = period;
    
```

Fig. 8: DMPA Initialize True Time Kernal and Task Attributes

According to the various setting on execution time as shown in Fig. 7, some results can be investigated. By increasing the execution time, the stability of the single cart GCS is slowly disrupted. It can be seen clearly in Fig. 9.

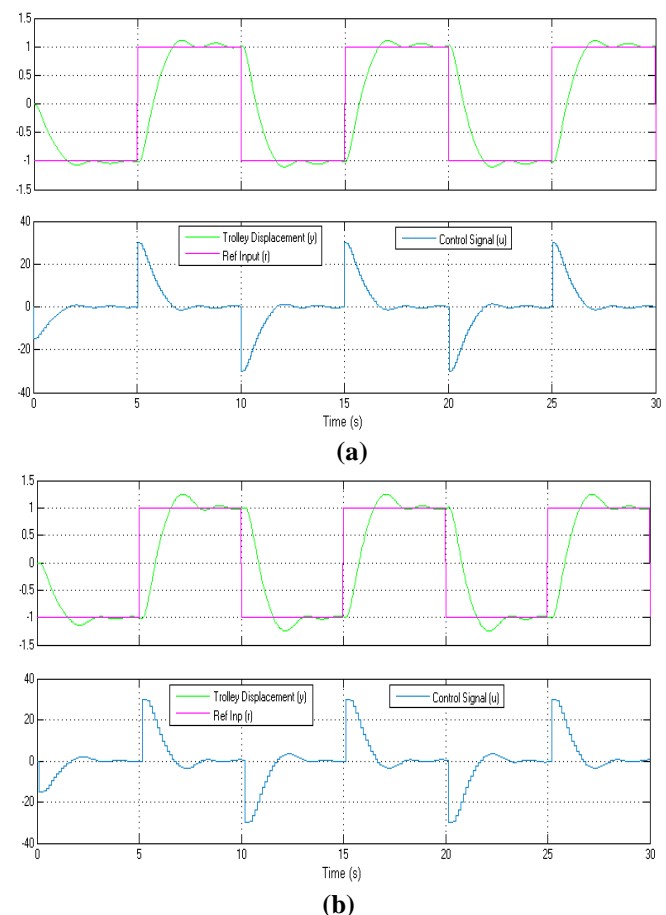

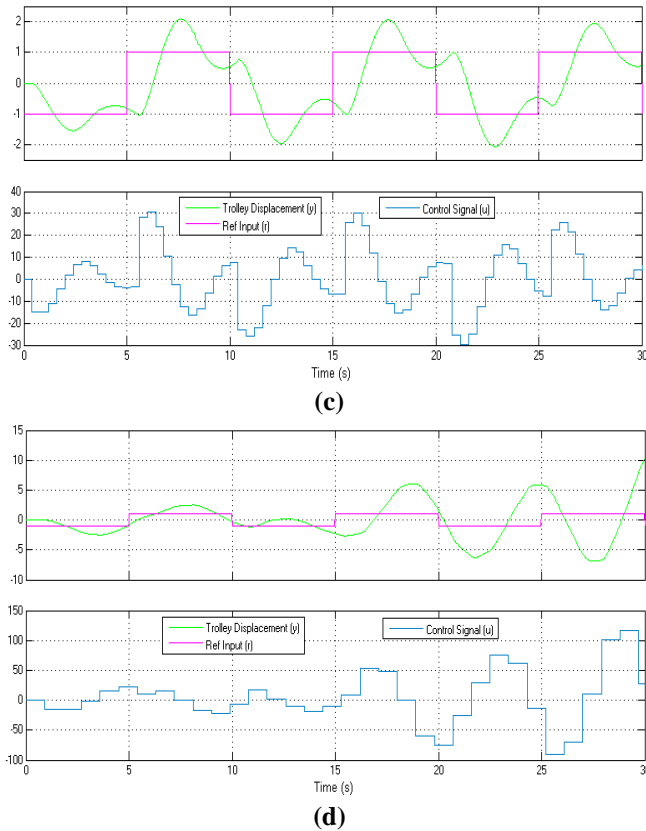

**Fig. 9: Reference Input (r), Trolley Displacement (y) and Control Signal (u) for DMPA**  
 (a) Case 1 (b) Case 2 (c) Case 3 (d) Case 4

**A. Simulation Result of EDF**

For EDF, the priority call is set as `ttInitKernel('prioEDF')` as shown in Fig.10. This coding for priority DMPA called by the TRUETIME kernel block.

```

% Initialize True Time kernel
ttInitKernel('prioEDF');

% Task attributes
period = 0.06;
deadline = period;
    
```

**Fig.10: EDF Initialize True Time Kernel and Task Attributes**

The same step and procedure has been implemented for EDF investigation and the results can be seen in Fig.10.

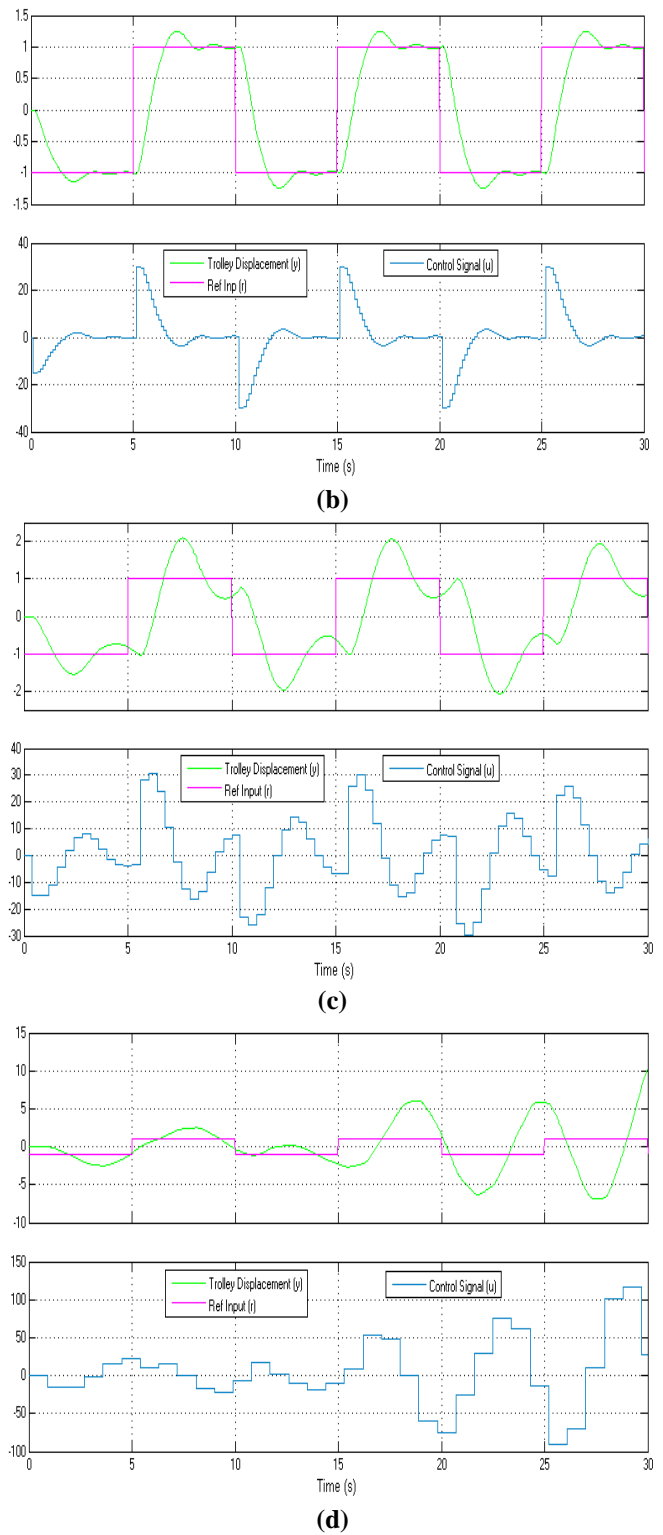
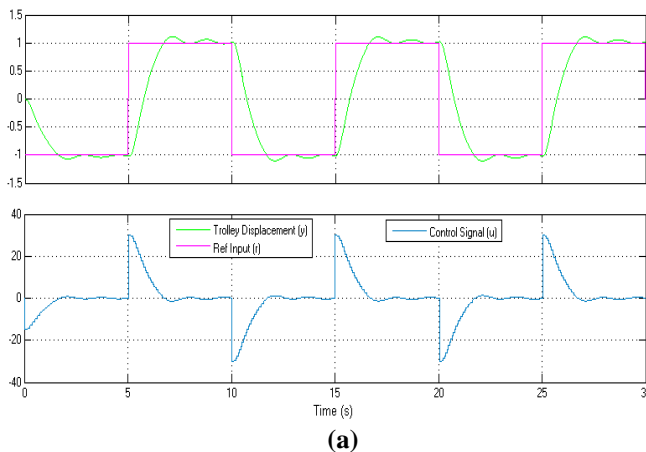

**Fig. 10: Reference Input (r), Trolley Displacement (y) and Control Signal (u) for EDF**  
 (a) Case 1 (b) Case 2 (c) Case 3 (d) Case 4

Based on the analysis from the DMPA and EDF algorithm, the results are similar. Furthermore, it is shown that if execution time is within the period limit, the corresponding output is stable. Even though the execution time is increased to 0.12 s (the value of execution time has increased at 6%), the system still stable (soft real time) but the percentage of overshoot is increased. However, the performances of output are going to be unstable (execution time has increased at 20%). The system is totally unstable if the execution time is increased as 0.90 s.

**Table 1: Effect of Control Performances**

Case	Execution Time (s)	Period (s)	Control Performances	
			Overshoot (%)	Settling Time (s)
1	0.02	0.006	6	3.1
2	0.12	0.006	23	3.3
3	0.40	0.006	50	> 5

## V. CONCLUSION

The stability and real time execution of any system is very important. Thus, implementation of two types scheduling algorithm is chosen to investigate the stability of single cart GCS for various execution times. In this study, only cart displacement is focused because the effectiveness of payload oscillation depends on cart stability. It will help this system be more effective and applicable in safe environments. Based on this study, the system is will be unstable if the execution time is increased.

## VI. ACKNOWLEDGMENT

The authors would like to thank Universiti Teknikal Malaysia Melaka (UTeM) for sponsoring this project. This project was conducted under the university short-term grant PJP/2013/FKE(25C)/S01256. Deep appreciations are also dedicated to anyone who directly or indirectly involved in this project.

## REFERENCES

- [1] H. I. Jaafar, Z. Mohammed, J. J. Jamian, A. F. Z. Abidin, A. M. Kassim, and Z. A. Ghani, "Dynamic Behaviour of a Nonlinear Gantry Crane System," *Procedia Technology*, vol. 11, pp. 419-425, 2013.
- [2] H. I. Jaafar, N. M. Ali, Z. Mohamed, N. A. Selamat, A. M. Kassim, A. F. Z. Abidin, and J. J. Jamani, "Optimal Performance of a Nonlinear Gantry Crane System via Priority-based Fitness Scheme in Binary PSO Algorithm," *IOP Conference Series: Materials Science and Engineering*, Vol. 53, 2013, 012011.
- [3] H. I. Jaafar, Z. Mohamed, A. F. Z. Abidin, Z. M. Sani, J. J. Jamian, and A. M. Kassim, "Performance Analysis for a Gantry Crane System (GCS) using Priority-based Fitness Scheme in Binary Particle Swarm Optimization," *Advanced Materials Research*, Vol. 903, 2014, pp. 285-290.
- [4] A. Masrur, S. Chakraborty, and G. Farber, "Constant-time Admission Control for Deadline Monotonic Tasks," *Design, Automation & Test in Europe Conference & Exhibition, Dresden, Germany, March 8-12, 2010*, pp. 220-225.
- [5] R. I. Davis and A. Burns, "Improved Priority Assignment for Global Fixed Priority Pre-emptive Scheduling in Multiprocessor Real-Time Systems", 2008.
- [6] S. Kato and N. Yamasaki, "Semi-partitioned Fixed-Priority Scheduling on Multiprocessors," 15th IEEE Real-Time Embedded Technology and Application. Symposium, San Francisco, California, April 13-16, 2009, pp. 23-32.
- [7] G. Yao, G. Buttazzo, M. Bertogna, S. Superiore, and S. Anna, "Bounding the Maximum Length of Non-Preemptive Regions Under Fixed Priority Scheduling", no. 216008, 2013.
- [8] O. A. Ghiasvand and M. A. Sharbafi, "Using Earliest Deadline First Algorithms for Coalition Formation in Dynamic Time-critical Environment", *International Journal of Information and Education Technology*, vol. 1, no. 2, pp. 120-125, 2011.
- [9] S. K. Baruah, V. Bonifaci, and G. D. Angelo, "Mixed-Criticality Scheduling of Sporadic Task Systems," vol. 6942, pp. 555-566, 2011.
- [10] A. Dua, C. Chan, and N. Bambos, "Channel, Deadline, and Distortion (CD 2) Aware Scheduling for Video Streams Over Wireless", vol. 3, no. 3, pp. 1001-1011, 2010.

- [11] M. I. Solihin, Wahyudi, M.A.S Kamal and A. Legowo, "Optimal PID Controller Tuning of Automatic Gantry Crane Using PSO Algorithm," *Proceeding of the 5<sup>th</sup> International Symposium on Mechatronics and its Applications (ISMA08)*, Amman, Jordan, May 27-29, pp. 1-5, 2008.
- [12] H. I. Jaafar, M. F. Sulaima, Z. Mohamed, and J. J. Jamian, "Optimal PID Controller Parameters for Nonlinear Gantry Crane System via MOPSO Technique", *IEEE Conference on Sustainable Utilization and Development in Engineering and Technology*, Selangor, Malaysia, May 30-June 1, 2013, pp. 86-91.
- [13] H. I. Jaafar, Z. Mohamed, J. J. Jamian, M. S. M. Aras, A. M. Kassim, M. F. Sulaima, "Effects of Multiple Combination Weightage using MOPSO for Motion Control Gantry Crane System", *Journal of Theoretical and Applied Information Technology*, vol. 63, no. 3, 2014, pp. 807-813.



**Mohamad Syarafuddin Omar**, currently pursue his B.Eng degree in Electrical Engineering from Universiti Teknikal Malaysia Melaka (UTeM), in 2014.



**Hazriq Izzuan Jaafar**, received his B.Eng degree in Electrical Engineering from Universiti Teknologi Malaysia (UTM), in 2008. He received the M.Eng degree in Mechatronics and Automatic Control engineering also from UTM, in 2013. Currently, he is a Lecturer at Universiti Teknikal Malaysia Melaka (UTeM) and his interests are in control system and optimization techniques.



**Rozaimi Ghazali**, received his B.Eng degree in Electrical Engineering (Instrumentation and Control) from Universiti Teknologi Malaysia (UTM), in 2008. He received the Ph.D in Electrical Engineering also from UTM, in 2013. Currently, he is a senior lecturer at Universiti Teknikal Malaysia Melaka (UTeM) and his interests are in system identification and robust controller design.



**Syahrul Hisham Bin Mohamad**, received his B.Eng degree in Electrical and Electronic from UNITEN, in 2003. He received the M.Eng degree in Mechatronics and Automatic Control engineering also from UTM, in 2013. Currently, he is a Lecturer at Universiti Teknikal Malaysia Melaka (UTeM) and his interests are in Power Electronics and Drive, Sensors, Renewable and Sustainable Energy.



**Khalil Azha Mohd Annuar**, received his B.Eng degree in Electrical Engineering (Electronic) from Universiti Teknologi Malaysia (UTM), in 2006. He received the M.Eng degree in Mechatronics and Automatic Control engineering also from UTM, in 2014. Currently, he is a Lecturer at Universiti Teknikal Malaysia Melaka (UTeM) and his interests are in control system and artificial intelligent.