

PID Control Tuning VIA Particle Swarm Optimization for Coupled Tank System

S.Y.S Hussien, H.I Jaafar, N.A Selamat, F.S Daud, A.F.Z Abidin

Abstract—This paper presents the use of meta-heuristic technique to obtain three parameters (K_P , K_I and K_D) of PID controller for Coupled Tank System (CTS). Particle Swarm Optimization (PSO) is chosen and Sum Squared Error is selected as objective function. This PSO is implemented for controlling desired liquid level of CTS. Then, the performances of the system are compared to various conventional techniques which are Trial and Error, Auto-Tuning, Ziegler-Nichols (Z-N) and Cohen-Coon (C-C) method. Simulation is conducted within Matlab environment to verify the transient response specifications in terms of Rise Time (T_R), Settling Time (T_S), Steady State Error (SSE) and Overshoot (OS). Result obtained shows that performance of CTS can be improved via PSO as PID tuning methods.

Index Terms—Coupled Tank System (CTS), Particle Swarm Optimization (PSO), PID Controller, PID Tuning Method.

I. INTRODUCTION

Coupled Tank System (CTS) is one of the applications in industrial production as shown in Figure 1. The process control especially controlling liquid level is important and widely applied in various field such as liquid storage tank, a feeding tank, a product tank, the intermediate buffer containers and water tanks [1-2]. In CTS, the overall process need liquids to be pumped, stored in the tank and pumped again to another tank for certain desired level. The liquid is required to be maintained in a specific height or certain range [3]. Efficient and effective controls of these processes have immense economical advantage and its success depends on the type of control strategy [4].

CTS is a typical representative of the process control. It has nonlinear and complex characteristics. PID controller is implemented to the system to control the desired level of the water and this controller always been used in industrial application due to easy and simple design to implement [5-6]. Nevertheless, the conventional PID controller shows that it is difficult to reach the desired control response with the aim of high speed with short transition time and small overshoot [7]. In order to achieve the optimal specifications, Particle Swarm Optimization (PSO) algorithm is approached. The advantage of PSO is a fast convergence compares with many optimizations [5-6]. It is also easy in its concept and coding implementation.

Manuscript received on May, 2014.

S.Y.S. Hussein, Faculty of Electrical Engineering (FKE), Universiti Teknikal Malaysia Melaka (UTeM).

H.I. Jaafar, Faculty of Electrical Engineering (FKE), Universiti Teknikal Malaysia Melaka (UTeM), Hang Tuah Jaya, 76100 Durian Tunggal, Malaysia .

N.A. Selamat, Faculty of Electrical Engineering (FKE), Universiti Teknikal Malaysia Melaka (UTeM).

F.S. Daud, Faculty of Electrical Engineering (FKE), Universiti Teknikal Malaysia Melaka (UTeM).

A.F.Z. Abidin, Faculty of Electrical Engineering (FKE), Universiti Teknologi MARA (UiTM).

Furthermore, PSO is potential to replace the conventional way of obtaining PID controller parameters [8].

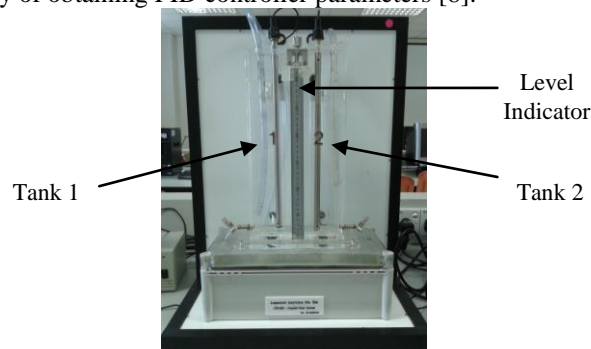

Figure 1: Coupled Tank CTS-001

II. PID CONTROLLER

PID controller is a control feedback mechanism controller which is widely used in industrial control system. PID controller involves three-term control which are the Proportional (P), the Integral (I) and the Derivative (D). PID controller is used to calculate an error value as the difference between a measured process variable and a desired set point. It also used to minimize the error by adjusting the process of control inputs.

$$u(t) = K_p e(t) + K_i \int e(t) dt + K_d \frac{de}{dt}(t) \quad (1)$$

$$= K_p \left[e(t) + \frac{1}{T_i} \int e(t) dt + T_d \frac{de}{dt}(t) \right]$$

In the system, three parameters are needed to be tuned. One of the parameters is proportional gain, K_P . This controller has the effect of reducing the Rise Time (T_R) and Steady State Error (SSE) but the percentage of the Overshoot (OS) in the system is high. In the integral controller, K_I as the integral gain will affect and decrease the rise time. However, it will eliminate the SSE of the system. Even though it eliminates the error but the percentage of the OS is increased and it will affect the Settling Time (T_S) as well. In order to improve the performance of the system, derivative gain, K_D in the derivative controller is introduced. This controller will take action to improve the transient specification and stability of the system. The effects of the each of the controller on a closed-loop system are summarized in Table 1.

Table 1: PID Controller Properties

	Effect of Performance			
	T_R	T_S	O_S	SSE
KP	Decrease	Small Change	Increase	Decrease
KI	Decrease	Increase	Increase	Eliminate

KD	Small Change	Decrease	Decrease	Small Change
----	--------------	----------	----------	--------------

In order to improve the high stability and short transient response of the system, the optimal gain value must be obtained from the PID tuning. Even though it is only three control parameters, but to adjust the parameter referred to the Table 1 are difficult. Therefore, many methods are implemented in order to obtain the best parameter of PID controller.

III. MATHEMATICAL MODELING

It is vital to understand the mathematics modeling of the behavior of CTS. In this system, the nonlinear dynamic model is observed and the linearization process is done based on the nonlinear model.

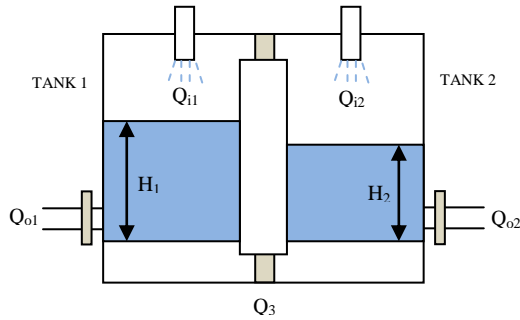

Figure 2: Schematic diagram of CTS

Based on Figure 2, H_1 and H_2 are the fluid level in Tank 1 and Tank 2. It is measured with respect to the corresponding outlet. Considering a simple mass balance, the rate of change of fluid volume in each tank equals the net flow of fluid into the tank. Therefore, the equation for Tank 1 and Tank 2 are:

$$A_1 \frac{dH_1}{dt} = Q_{i1} - Q_{o1} - Q_3 \quad (2)$$

$$A_2 \frac{dH_2}{dt} = Q_{i2} - Q_{o2} + Q_3 \quad (3)$$

where:

- H_1, H_2 = height of fluid in Tank 1 and 2 respectively
- A_1, A_2 = cross-sectional area of Tank 1 and 2 respectively
- Q_3 = flow rate of fluid between tanks
- Q_{i1}, Q_{i2} = pump flow rate into Tank 1 and 2 respectively
- Q_{o1}, Q_{o2} = flow rate of fluid out of Tank 1 and 2 respectively

Each outlet drain can be modeled as a simple orifice. Bernoulli's equation for steady, non-viscous, incompressible shows that the outlet flow in each tank is proportional to the square root of the head of water in the tank. Similarly, the flow between the tanks is proportional to the square root of the head differential. Thus:

$$Q_{o1} = \alpha_1 \sqrt{H_1} \quad (4)$$

$$Q_{o2} = \alpha_2 \sqrt{H_2} \quad (5)$$

$$Q_3 = \alpha_3 \sqrt{H_1 - H_2} \quad (6)$$

where α_1, α_2 and α_3 are proportionality constants which is depend on the coefficients of discharge, the cross sectional area of each orifice and the gravitational constant. By substitute (4), (5) and (6) into (2) and (3), the nonlinear state equations which describe the system dynamics of the CTS apparatus are:

$$A_1 \frac{dH_1}{dt} = Q_{i1} - \alpha_1 \sqrt{H_1} - \alpha_3 \sqrt{H_1 - H_2} \quad (7)$$

$$A_2 \frac{dH_2}{dt} = Q_{i2} - \alpha_2 \sqrt{H_2} + \alpha_3 \sqrt{H_1 - H_2} \quad (8)$$

In the second order configuration, h_2 is the process variable and q_1 is the manipulated variable and assume that q_2 is zero. The block diagram of the second-order system can be simplified as shown in Figure 3.

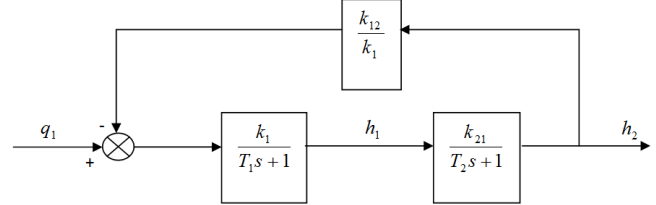

Figure 3: Block diagram of second order system

Thus, the nonlinear CTS can be obtained as:

$$\begin{aligned} \frac{h_2(s)}{q_1(s)} &= \frac{k_1 k_2}{(T_1 s + 1)(T_2 s + 1) - k_{12} k_{21}} \\ &= \frac{k_1 k_2}{T_1 T_2 s^2 + (T_1 + T_2)s + (1 - k_{12} k_{21})} \end{aligned} \quad (9)$$

where:

$$T_1 = \frac{A_1}{\left(\frac{\alpha_1}{2\sqrt{H_1}}\right) + \left(\frac{\alpha_3}{2\sqrt{H_1 - H_2}}\right)} \quad (10)$$

$$T_2 = \frac{A_2}{\left(\frac{\alpha_2}{2\sqrt{H_2}}\right) + \left(\frac{\alpha_3}{2\sqrt{H_1 - H_2}}\right)} \quad (11)$$

$$k_1 = \frac{1}{\left(\frac{\alpha_1}{2\sqrt{H_1}}\right) + \left(\frac{\alpha_3}{2\sqrt{H_1 - H_2}}\right)} \quad (12)$$

$$k_2 = \frac{1}{\left(\frac{\alpha_2}{2\sqrt{H_2}}\right) + \left(\frac{\alpha_3}{2\sqrt{H_1 - H_2}}\right)} \quad (13)$$

$$k_{12} = \frac{\frac{\alpha_3}{2\sqrt{H_1 - H_2}}}{\left(\frac{\alpha_1}{2\sqrt{H_1}}\right) + \left(\frac{\alpha_3}{2\sqrt{H_1 - H_2}}\right)} \quad (14)$$

$$k_{21} = \frac{\frac{\alpha_3}{2\sqrt{H_1 - H_2}}}{\left(\frac{\alpha_2}{2\sqrt{H_2}}\right) + \left(\frac{\alpha_3}{2\sqrt{H_1 - H_2}}\right)} \quad (15)$$

The transfer function for the plant can be obtained by substituting the parameter which was provided from the [9] and the parameters are shown in Table 2.

Table 2: Parameter of CTS

Parameters	Value	Unit
H_1	17	cm
H_2	15	cm
α_1	10.78	cm ^{3/2} /sec
α_2	11.03	cm ^{3/2} /sec

α_3	11.03	$\text{cm}^{3/2}/\text{sec}$
A_1	32	cm^2
A_2	32	cm^2

Then, all the parameters in Table 1 have been inserted into (9). Thus, the actual transfer function of the plant with the completed value is:

$$G_p(s) = \frac{h_2(s)}{q_1(s)} = \frac{0.0361}{36.9406s^2 + 12.1565s + 0.4514} \quad (16)$$

IV. PARTICLE SWARM OPTIMIZATION (PSO)

PSO is introduced by Kennedy and Eberhart [10]. It was first intended for simulation social behavior, as a stylized representation of the movement of organisms in a bird flock or fish school. While searching for food, the birds are either scattered or go together before they locate the place where they can find the food. While the birds are searching for food from one place another, there is always a bird that can smell the food well, that is the bird is perceptible of the place where the food can be found, having the better food resource information. Because they are transmitting the information, especially the good information at any time while searching the food from one place to another, conducted by the good information, the birds will eventually flock to the place where food can be found [11].

The basic principle of the PSO algorithm is it uses a number of particles (agents) that constitute a swarm moving around in the search space looking for the best solution. Each of the particles is treated as a point in N-dimensional space which adjusts its flying according to its own flying experience as well as the flying experience as well as the flying experience of other particles. Each particle keeps track of its coordinates in the solution space which are associated with the best solution (fitness) that has achieved so far by that particle. This value is known as personal best, P_{BEST} . Another best value that is tracked by the PSO is the best value obtained so far by any particle in the neighborhood of that particle which known as global best, G_{BEST} .

Each particle can be shown by its current velocity and position as shown in (17) and (18). Figure 4 shows the overall process of PSO.

$$v^{i+1} = \omega v^i + c_1 r_1 (P_{BEST} - x^i) + c_2 r_2 (G_{BEST} - x^i) \quad (17)$$

$$x^{i+1} = x^i + v^{i+1} \quad (18)$$

where:

- v^{i+1} = velocity of particle at iteration k
- ω = inertia weight factor
- c_1, c_2 = acceleration coefficients
- r_1, r_2 = random numbers between 0 and 1
- x^{i+1} = position of particle at iteration k

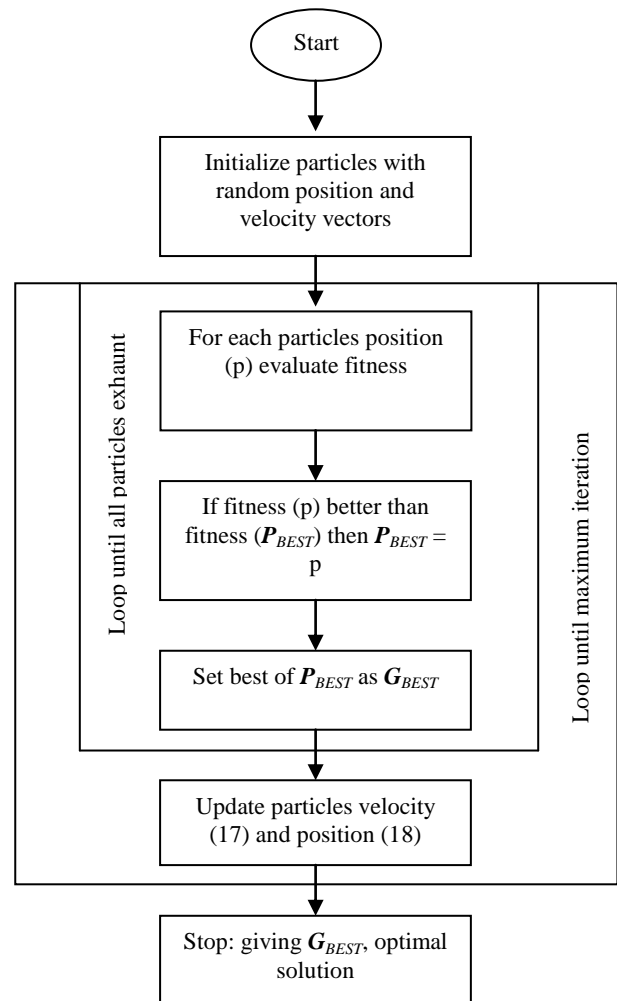

Figure 4: Flow chart depicting of general PSO

V. RESULTS AND DISCUSSION

The plant of the CTS is obtained from the mathematical modeling in previous chapter. The input voltage injected in the system is 1 Volt and the level converter (gain) will convert the input voltage to the water level. The desired level is 1 cm. The control structure with PID Controller of the CTS is shown in Figure 5 [7].

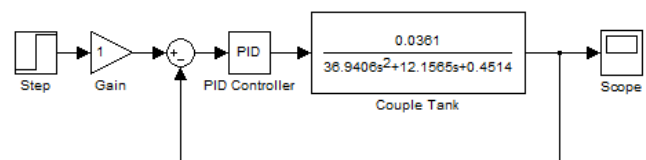

Figure 5: Control structure with PID Controller

Simulation exercise are conducted with AMD Turion 64 X2 Processor, 4GB RAM, Microsoft Window 7 and MATLAB as a simulation platform. In this study, 20 particles are considered with 100 iterations. As default values, c_1 and c_2 are set as 2. The initial value of ω is 0.9 and linearly decreased to 0.4 at some stage of iteration. Table 3 shows the optimal PID parameter (K_p, K_i and K_d) obtained using PSO.

Table 3: PID parameter based on PSO

Parameter	Value
K_P	250.9928
K_I	4.3478
K_D	171.6427

The control structure in Figure 5 is then simulated with the PSO-tuned controller parameter. The response of the system is shown in Figure 6. It shows that, PSO achieved the desired water level and improved the settling time of the system. Table 4 summaries system specifications obtained with PID controller. Figure 7 shows the performance response of the system.

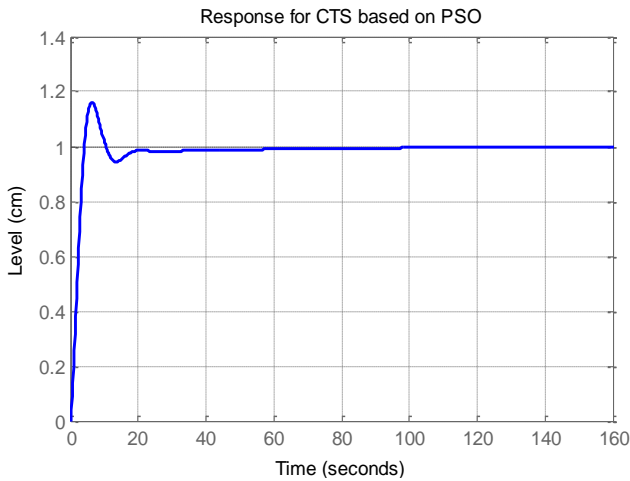

Figure 6: Response of CTS based on PSO

Table 4: Performance of CTS based on PSO

	T_s (sec)	T_R (sec)	OS (%)	SSE (cm)
PSO	17.7519	3.2691	16.1877	0.0000

Figure 8 and Table 5 shows summarize system performances obtained with PID controller. It shows that PSO-tuned method had better performance for CTS compared to the conventional tuning methods which were trial and error, auto-tuning, Z-N and C-C.

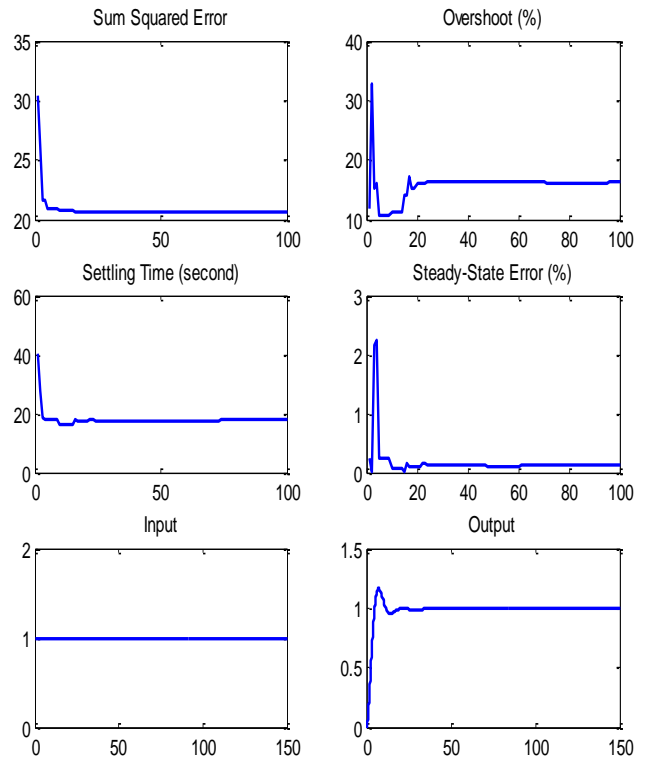

Figure 7: Performance Response of CTS based PSO

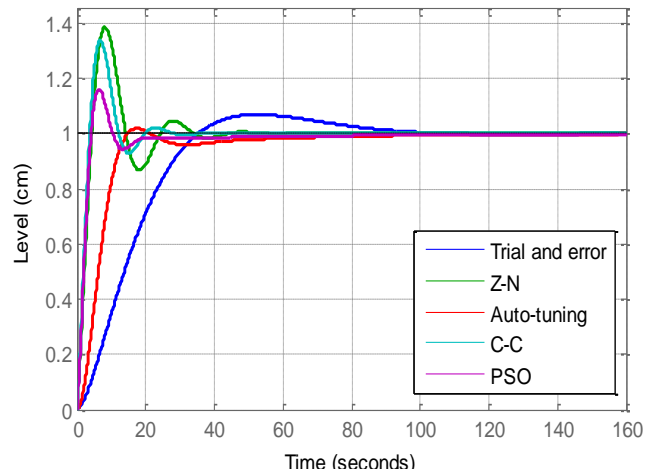

Figure 8: Response of CTS based on conventional tuning method and PSO

Table 5: Performances of CTS based on conventional tuning method and PSO

Method	T_s (sec)	T_R (sec)	OS (%)	SSE (cm)
Trial and error	84.4029	24.0334	6.8592	0.0000
Auto-tuning	53.3368	9.1404	1.8112	0.0000
Z-N	32.0856	3.2943	38.5350	0.0000
C-C	23.5904	2.8105	33.6989	0.0000
PSO	17.7519	3.2691	16.1877	0.0000

VI. CONCLUSION

As conclusion, this paper presents the study of an optimization method which was PSO and other various traditional tuning methods in order to obtain the optimal PID controller parameters. From the analysis, PID-tuned by PSO shown a better performance and successfully

reduce the values of T_S , T_R , OS and SSE than conventional methods. However, this optimization might not be the best tuning method in order to obtain the best parameter for PID controller for CTS. Further research with other optimization is required to compare the performance of the system.

ACKNOWLEDGMENT

Authors would like to thanks Universiti Teknikal Malaysia Melaka (UTeM) for sponsoring this project. This project was conducted under the university short-term grant PJP/2013/FKE(7C)/S01178. Deep appreciations are also dedicated to anyone who directly or indirectly involved in this project.

REFERENCES

- [1] M. Abid, "Fuzzy Logic Control of Coupled Liquid Tank System", International Conference on Information and Communication Technologies, 27-28 August 2005, Karachi, Pakistan, pp. 144-147.
- [2] M. F. Rahmat and S.M. Rozali, "Modelling and Controller Design for a Coupled-Tank Liquid Level System: Analysis & Comparison", Journal of Technology, vol. 48 (D), June, 2008, pp. 113-141.
- [3] H. Abbas, S. Asghar, S. Qamar, "Sliding Mode Control for Coupled-Tank Liquid Level Control System", International Conference on Frontiers of Information Technology, 17-19 Dec. 2012, Islamabad, Pakistan, pp. 325-330.
- [4] K. O. Owa, S. K. Sharma, R. Sutton, "Optimised Multivariable Nonlinear Predictive Control for Coupled Tank Applications", IET Conference on Control and Automation, 4-5 June 2013, Birmingham, England, pp. 1-6.
- [5] N. A. Selamat, N. A. Wahab, and S. Sahlan, "Particle Swarm Optimization for Multivariable PID Controller Tuning", 2013 IEEE 9th International Colloquium on Signal Processing and its Applications, 8-10 March 2013, Kuala Lumpur, Malaysia, pp. 170-175.
- [6] H. I. Jaafar, Z. Mohamed, A. F. Z. Abidin and Z. A. Ghani, "PSO-Tuned PID Controller for a Nonlinear Gantry Crane System", 2012 IEEE International Conference on Control System, Computing and Engineering, 23-25 Nov. 2012, Penang, Malaysia, pp. 515-519.
- [7] H. I. Jaafar, S. Y. S. Hussien, N. A. Selamat, M. S. M. Aras and M. Z. A. Rashid, "Development of PID Controller for Controlling Desired Level of Coupled Tank System", International Journal of Innovative Technology and Exploring Engineering, vol. 3 (9), Feb. 2014, pp. 32-36.
- [8] I. M. Khairuddin, A. S. A. Dahalan, A. F. Z. Abidin, Y. Y. Lai, N. A. Nordin, S. F. Sulaiman, H. I. Jaafar, S. H. Mohamad, N. H. Amer, "Modeling and Simulation of Swarm Intelligence Algorithms for Parameters Tuning of PID Controller in Industrial Couple Tank System", Advanced Materials Research, vol. 903, Feb. 2014, pp. 321-326.
- [9] Coupled-Tank Liquid Level Computer-Controlled Laboratory Teaching Package: Experimental and Operation (Service) Manual, Augmented Innovation Sdn. Bhd., Kuala Lumpur, Malaysia.
- [10] J. Kennedy and R. Eberhart, "Particle Swarm Optimization", Proceedings of the 1995 IEEE International Conference on Neural Networks, Perth, WA, 27 Nov. - 1 Dec. 1995, pp. 1942-1948.
- [11] Q. Bai, "Analysis of Particle Swarm Optimization Algorithm", Computer and Information Science, vol 3 (1), February 2010, pp. 180-184.



Sharifah Yulsinda Syed Hussien received her Diploma in Electrical Engineering from Universiti Teknikal Malaysia Melaka (UTeM), in 2011. Currently, she pursues her degree in Electrical Engineering in Control, Instrumentation and Automation System, UTeM.



Hazriq Izzuan Jaafar received his B.Eng degree in Electrical Engineering from Universiti Teknologi Malaysia (UTM), in 2008. He received the M.Eng degree in Mechatronics and Automatic Control engineering also from UTM, in 2013. Currently, he is a

Lecturer at Universiti Teknikal Malaysia Melaka (UTeM) and his interests are in control system and optimization techniques.



Nurasmiza Selamat received her B.Eng degree in Electrical Engineering from Universiti Teknologi Malaysia (UTM), in 2009. She received the M.Eng degree in Mechatronics and Automatic Control engineering also from UTM, in 2013. Currently, she is a Lecturer at Universiti Teknikal Malaysia Melaka (UTeM) and his interests are in control system and optimization techniques.



Fiona Serina Daud received her Diploma in Electrical Engineering from Universiti Teknikal Malaysia Melaka (UTeM), in 2011. Currently, she pursues her degree in Electrical Engineering in Control, Instrumentation and Automation System, UTeM.



Amar Faiz Zainal Abidin received his Bachelor of Engineering in Electrical & Electronics from University of Nottingham in 2008. While working as Tutor in Universiti Teknologi Malaysia (UTM), he completed his master degrees: Master of Engineering in Electrical (Mechatronics & Automatic Control) from UTM and Master of Science in Computer Vision from University of Burgundy. Currently, he serves Universiti Teknologi MARA as a Lecturer and his main research interest is in Computational Intelligence.