

World Applied Sciences Journal 30 (Innovation Challenges in Multidisciplinary Research & Practice): 395-402, 2014
ISSN 1818-4952
© IDOSI Publications, 2014
DOI: 10.5829/idosi.wasj.2014.30.icmrp.55

Data Accessibility Model Using QR Code for Lifetime Healthcare Records

Fathin N. M. Leza and Nurul A. Emran

Department of Software Engineering, Faculty of Information and Communication Technology,
Universiti Teknikal Malaysia Melaka (UTeM), Melaka, Malaysia

Submitted: Jan 5, 2014; **Accepted:** Feb 24, 2014; **Published:** Mar 12, 2014

Abstract: One factor that determines the quality of healthcare services is the accessibility of patient records. Fast and seamless access to patient records is necessary in order to support sharing of complete lifetime patient records among healthcare providers while promoting the greater use of it. Nevertheless, studies on how complete lifetime patient record can be acquired by improving the way these records are accessed are limited. In this paper, the conceptual model of data accessibility in healthcare domain will be presented. QR code technology will be adopted in the model as a tool that enables multi-platforms data access points. Incremental data updates will be used as a mean to share complete, up-to-date lifetime patient records. Software prototype architecture and the interface design of the model will be also presented in this paper. The contribution of the work is on improving lifetime patient records accessibility that consequently promotes sharing of complete patient records among healthcare providers.

Key words: Data Accessibility • Mobile Application • QRCode • Healthcare Records

INTRODUCTION

In electronic healthcare environment the prominent concern is not only on the accessibility of specific records of the patient under treatment, but also on the accessibility of his/her lifetime patient records. Acquiring complete lifetime patient records is crucial as information about patients' past treatments (and past healthcare providers), allergies, basic information (e.g. blood type and inherited diseases) will determine how accurate doctors/physicians can diagnose certain disease before suitable type of treatments and prescriptions can be recommended. Ideally, complete lifetime patient records hold information about a person's medical history from born until now. As one usually gets medical treatments from more than one healthcare provider (i.e. clinics, hospitals, rehabilitation centers and etc.) sharing of complete lifetime patient records among healthcare providers is a requirement that demands for fast and seamless access to these records. The consequence of incomplete patient records unfortunately must be borne by the patients. For example, as some records about a patient under treatment is missing he/she will be required

experiencing similar tedious, time-consuming and painful medical procedures every time they are admitted for treatment (in one or more healthcare provider) until patient records that are acceptably 'complete' can be acquired.

The example just given portrays a lack of records sharing problem among healthcare providers which is caused by limited data access. In reality, one obstacle of data sharing that can be observed is the complexity of performing full data integration among healthcare providers' data sources. Even though full data integration can provide unified view and access of data from different data sources, one requirement of this approach is to resolve differences (called heterogeneity) among the participating healthcare systems (e.g. in term of hardware and data management software). This requirement makes the task of accessing and gathering complete lifetime patient data expensive and impractical. Therefore in this paper, we propose a data accessibility model which is a departure from the full data integration approach that eases the task of gathering complete lifetime patient data.

Before we can design (and evaluate) the model prototype, we must understand the state-of-the art of data accessibility methods available. Therefore in the next

Corresponding Author: Fathin N.M. Leza, Department of Software Engineering, Faculty of Information and Communication Technology, Universiti Teknikal Malaysia Melaka (UTeM), Melaka, Malaysia.

section, works related to data accessibility will be presented. This is followed by description about the model we proposed.

Related Work: Data accessibility is the ability to access the data regardless of natural or man-made disasters, hardware failures or others [1]. In data quality context, data accessibility is defined as the range to which data is available or easily and quickly retrievable [2]. There are several issues regarding to data accessibility as pointed out by researchers in several domains. For example, Smith pointed the problem for controlling illegal access of data [3]. The author suggests to utilize multi-level security database to authorized personnel only. This is for restricting the access for confidential information in the database problem [4].

Hara highlights data accessibility in ad-hoc network [5]. The problem raised is regarding restricted data accessibility for individual mobile host against data held by mobile hosts in other networks. To deal with the problem just described, Hara suggested data replication. Through data replication multiple replicas of data items are created in a network. As the result, data accessibility can be improved by increasing the probability of finding one copy of data in the network. Nevertheless, data replication is only possible when there are plenty of storage space, bandwidth and power in mobiles nodes [6]. Another method used to improve data accessibility is data caching or cooperative caching method [7, 8]. Atsan and Oskazap describe the usage of these methods in mobile ad hoc networks in order to enhance data availability and accessibility where several nodes are coordinated to share cached data in efficient way [8]. However, this method requires frequent data saving which increase complexity in application.

Amirian and Alesheikh highlighted the issues of accessing and sharing geospatial data [9]. Non-interoperability that inhibits geospatial data sharing and insufficient message exchange patterns limit the data accessibility to their users. By introducing online services called Open Geospatial Consortium Web Services (OGC Web Services) interoperability among heterogeneous data can be improved. Amirian and Alesheikh also proposed service oriented framework for disseminating geospatial data in many platforms(web, mobile and desktop)[9]. This framework implements various message exchange patterns to make the data accessible for various clients. However, using web services requires high speed connection as it carries a larger request for the service.

In one marine process managed by The International Oceanographic Data and Information Exchange (IODE) requires timely access of oceanographic data which has complexity of data exchange issue [10]. To address this issue, Reed *et. al* developed Ocean Data Portal (ODP) to facilitate seamless access to oceanographic data to promote the exchange and dissemination of marine data services [10]. In order to gain access to the data, IODE has initiated the ODP that established a single point of access to data collections and inventories via web services. This is achieved through the integration of marine data and other distributed resources of the participating systems. However, data integration implementers need to deal with data inconsistencies, data concurrency and integrity problems.

Cloud computing environment offers saving medical records “in the cloud” as a way to automate and accelerate access for patients, doctors and medical institutions [11]. In order to maintain secured data access and confidentiality in the clouds, Antony and Melvin presented an encryption scheme called HASBE that is able to encrypt stored data (of data owners) and decrypt them when accessed (by data consumers) [12]. Even so, the data consumers are not able to have write-access (update) for the data in the cloud as these data are read-only.

An effort to improve data accessibility has been reported Nakao, Okamoto *et. al* involving CyanoBase (a genome database for cyanobacteria) that employs hierarchical-type database in structure [14]. The organization of CyanoBase is re-arranged in order to improve data accessibility. Since CyanoBase consist of pages for viewing genome data, the pages are linked according to hierarchy and connectivity of the data [14]. A new keyword searching system is proposed to facilitate the access genome data in depth. Nevertheless, the method used by Nakao, Okamoto *et.al* do not describe how a piece of complete genome data can be queried.

In healthcare domain Albaie, Gorea and Felea proposed a medical system called as Telemon in order to ease access for critical patient data during emergency situation by medical staff on-duty [15]. These data were hard to be accessed in real-time by the medical officers on-duty when needed. A similar system called as TELEASIS has been proposed to improve accessibility of patient data such as patients’ medical history [16]. Purnama and Hartati emphasize a web-based system of Electronic Medical Record (EMR) to improve the availability and completeness of data retrieved [17].

Mobile cloud which is developed by Doukas, Pliakasl and Maglogiannis has been proposed as a method to manage mobile healthcare records [18]. This method aims to deal with data storage issue in mobile environment. Since the records are stored and presented as virtual folder, the storage structure of records is more transparent than the traditional database schema. This characteristic ease data accessibility for mobile devices users. Nonetheless, cloud storage users have to deal with data privacy issue.

Real-time data accessibility for diagnosing and monitoring patient records has been hindered by error-prone and slow data input and analysis processes [19]. To cope with this problem, Rolim *et. al*, proposed wireless sensor network and utility computing concept solution to automate data distribution and remote access by medical staff [19]. By using cloud computing to deliver integrated telemedicine service, patient records can be made available as needed. Nonetheless, this method does not describe how data can be accessed and updated in the case where more than one healthcare providers involved.

Even though accessing complete patient records is important in healthcare domain, little attention has been given on how these complete patient records can be accessed by from multiple healthcare providers. The work that we described so far unfortunately lack of discussion on how can we improve data accessibility in order to acquire complete patient data sets. In addition, these works are limited in terms of addressing how individual lifetime patient data can be accessed (and updated) by multiple healthcare providers in real-time. Therefore, in depth investigation is needed to address the gap in data accessibility studies just mentioned. We choose the healthcare domain to validate the usefulness of the model that we propose in this paper. In the next section, we will present the conceptual model of the work.

Data Accessibility Conceptual Model: Using UML use case diagram, the conceptual data accessibility model for healthcare domain is shown in Fig 1. The model, when implemented as a system prototype is called as Patient Lifetime Health System or shortly, PLHS.

This model has four actors who interact with the PLHS prototype. The details are as follow:

- Patient: a person who seeks medical service or treatment from healthcare provider and use the system to scan the QR Code. (Description of QR Code will be provided in sub-section A).

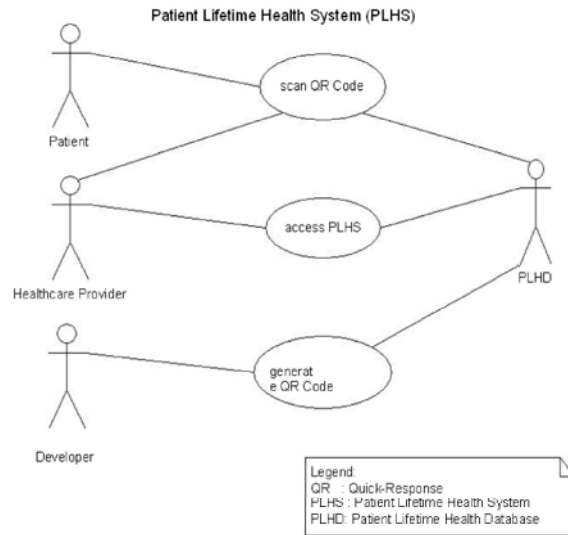

Fig. 1: A Conceptual Model of PLHS

- Healthcare Provider: an institution where the medical services are provided (e.g. clinics and hospital). Medical officers such as doctors/physicians who work at the healthcare provider have the privilege to view and update patient's record.
- Developer: a person who is responsible to generate QR Code that contains patient records.
- PL : a database that stores patients records

To describe the activities in 'scan QR Code' and 'access PLHS' use cases, we use a flow chart as shown Fig 2.

The system begins when a patient provides the QR Code to the medical officer for scanning where he/she seeks for treatment. The code can be scanned either through a desktop application's QR Code scanner or a Smartphone scanner (where the QR Code application is installed). Once the QR code is successfully decoded, an interface displaying patient's demographic data will be displayed. Then, the authorized medical officer (i.e. doctor) can login into PLHS. Every valid login will allow the medical officer to view the patient's data and update them. The patient's data will be saved into PLHD for every successful updates.

Fig. 3 shows the activities in 'generate QR Code' use case (Fig. 1).

The process begins by getting the registered patient's demographic information from the database PLHD. The patient's demographic information is determined by patient's



Fig. 2: Flow of PLHS Usage



Fig. 3: Flow of General Code in PLHS Usage

ID which is a unique identification for a patient. Then, the patient's records is encoded into QR Code using software specifically to generate the code. Every QR Code generated will be tested to check for its validity and readability. Any invalid QR Code will be re-encoded once the problems are rectified.

In the next sub-section, the usability of QR Code in several domains will be presented.

QR Code Applications: QR stands for Quick Response codes created in 1994 by Toyota subsidiary Denso-Wave where this special code is created as two-dimensional symbology [22]. This technology is the code advanced from the current barcode. It is initially used for tracking parts by vehicle manufacturers [23].

This QR code is quite useful for small businesses that wish to market their products and services. Using QR code are one of the marketing strategies that can be used [24, 25]. For example, information displayed on the business card can be shortened using the QR Code. This code is commonly used for labeling purposes in inventory management. The codes that store inventory information are printed on stickers or on papers. With the inventory system, the audit staff is able to scan the coded stickers on company properties to conduct regular audit [26].

QR Code is also used for sending short messages in SMS (short message service) which is generated for "ready -to-send" purpose [27]. By inputting recipient phone number and the content of messages, QR Code is encoded and is ready-to-send the message to the recipients. By this way, error caused by user inputs can be avoided. On the other side, QR Code is used as an authentication tool for online-banking [28]. It is used to confirm user's identity which is strengthened by one-time password (OTP). By this way, the system could verify the user's identity who attempt to access their account.

In educational domain, QR Codes has been used for students to access the questions and answers [29]. Students can also view multimedia resources directly from QR Code printed on the textbooks [29]. During an examination, candidates can use QR Code to access the questions directly from their mobiles [30]. QR code application in this context automates the entire process ranging from validating the answers to providing the exam results.

QR Code is also widely used in tourism. The code is used for guiding the tourist by providing voice-electronic tour-map [31]. It is used in tourist automatic navigation

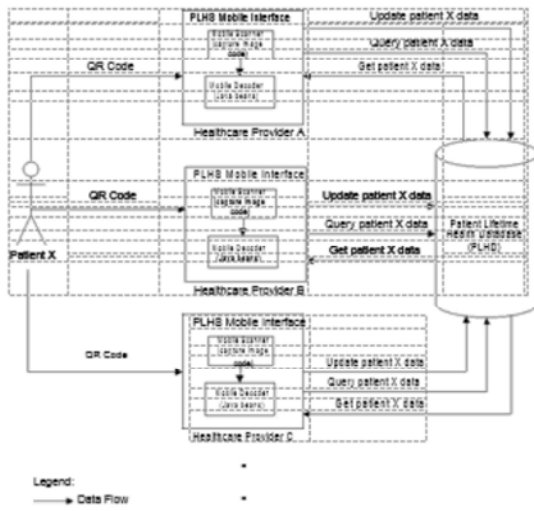

Fig. 4: PLHS architecture for mobile platform

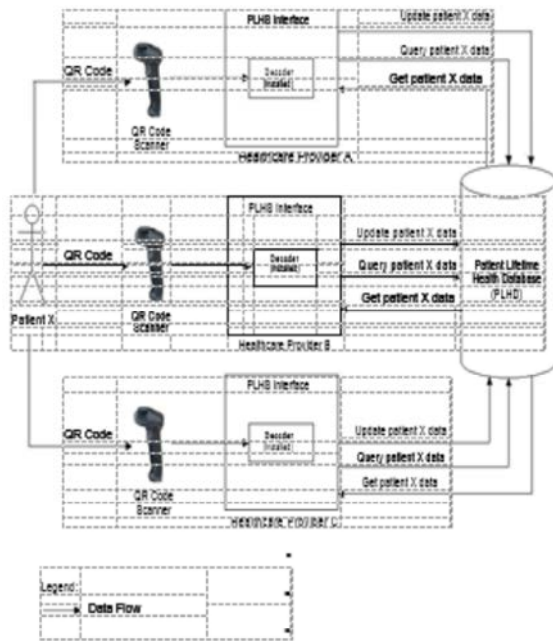

Fig. 5: PLHS architecture for desktop platform

service (i.e. PDA, Wireless) to get voice instruction guide in the electronic map to navigate the tourist to their destination.

In the healthcare domain, QR codes are mainly used in the hospitals in developed countries. For example, QR codes are used to make online appointments to schedule mammograms in Athens [32]. It is also used to promote hospital services in Nebraska and in labor and delivery room in Forte Collin [32].

The applications of QR Codes in various domains show its usefulness as data accessibility tool in marketing, shipping, inventory management, education, tourism and healthcare. This has been driven by several factors. These factors are its simple features, ease of use, cost-effective and more importantly instant access to the information [33]. In the next sub-section we will describe the architecture of PLHS where QR Code will be incorporated in the architecture.

System Prototype Architecture: In practice, PLHS will be implemented on the two platforms namely desktop and mobile. Fig. 4 depicts the architecture of PLHS for mobile platform. As depicted in the figure, suppose that a patient (Patient X) seeks healthcare services from several healthcare providers (A, B and C), at a different time interval. The QR Code is scanned in the PLHS interface that is developed in the application which later, is decoded into readable patient records. Every time Patient X gets the treatment, the corresponding healthcare provider’s doctors can view and update the patient’s data which is stored in PLHD. Through this way, the patient’s data will be incrementally updated throughout the patient’s lifetime.

Fig. 5 shows the architecture of PLHS for desktop platform. Unlike mobile platform, QR Code scanner is not embedded in the interface as it is a separate device connected to a desktop. A decoder application which is installed on the desktop will be used to decode the QR Code. PLHS Desktop architecture will be implemented by using web-based open-source software. Both architectures provide the same interface functionality (for decoding and retrieving data) but they will be implemented in a different way. In the next section we will present the design of PLHS interface for mobile devices.

PLHS User Interface: In this paper, user interface of PLHS for mobile platform will be shown. User interface for the mobile platform is developed using Java language with the latest language of HTML (HTML5) which is linked with a Zxing library for barcode application. HTML5 is chosen for its compatibility with many devices and platforms including Android, IOS or Blackberry. PLHS prototype will be developed in Android version 4.2.2 (Jelly Bean) environment. Figure 6 to 9 show the design of user interface for mobile devices.



Fig. 6: Design for Main user interface



Fig. 7: Design for QR Code Scanner interface



Fig. 8: Design for Patient Demographic display user interface

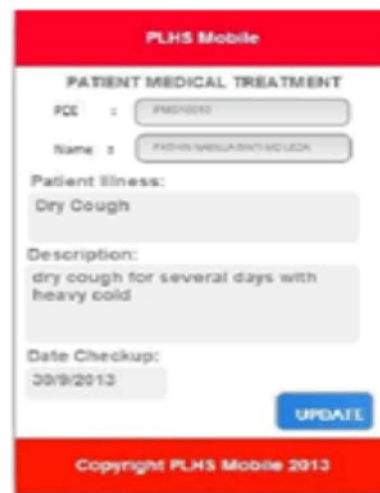

Fig. 9: Design for Updating Patient Data display user interface

RESULT

The expected result of this research is a new data accessibility model that improves completeness of lifetime patient data through incremental updates by multiple healthcare providers. A system prototype called as PLHS is the result implementing the conceptual model proposed in this research that will be available for desktop platform, as well as mobile platform.

Research Contribution: This research will contribute to the usage of complete lifetime patient data by improving data accessibility among healthcare providers. In addition to its real-time characteristic, the model that we propose support unlimited (and multi-platforms) access points that will be motivate patients' data sharing among healthcare providers.

Conclusion and Future Work: In conclusion, we presented the motivation of the work and the gaps in data accessibility studies. The result of this research will contribute towards better healthcare services. In the future, we will extend the work to cope with practical issues identified during the implementation of the system prototype.

ACKNOWLEDGMENT

The authors would like to thank Universiti Teknikal Malaysia Melaka (UTeM) for their support especially to

Faculty of Information Technology and Communication for their support and facilities along this research study. This research is sponsored by research grant FRGS (RACE)/ 2012/FTMK/SG05/01/1 F00155.

REFERENCES

1. Clio, "Blog Data Accessibility, Security and Privacy," 2008. [Online]. Available: <http://www.goclio.com/blog/2008/10/data-accessibility-security-and-privacy-part-i/>. [Accessed: 14-Oct-2013].
2. Pipino, L.L., Y.W. Lee and R.Y. Wang, 2002. "Data quality assessment," *Commun. ACM*, 45(4): 211, Apr. 2002.
3. Smith, G.D., 1994. "The accessibility," *Br. Med. J.*, 308: 1519-1520.
4. Adesina, A.O., K.K. Agbele, R. Februarie, A.P. Abidoye and H.O. Nyongesa, 2011. "Ensuring the security and privacy of information in mobile health-care communication systems," *S. Afr. J. Sci.*, 107(9/10): 1-7.
5. Hara, T., 2001. "Effective replica allocation in ad hoc networks for improving data accessibility," in *Proceedings IEEE INFOCOM 2001. Conference on Computer Communications. Twentieth Annual Joint Conference of the IEEE Computer and Communications Society (Cat. No.01CH37213)*, 3: 1568-1576.
6. Yin, L. and G. Cao, 2004. "Balancing the tradeoffs between data accessibility and query delay in ad hoc networks," *Proc. 23rd IEEE Int. Symp. Reliab. Distrib. Syst.* 2004. pp: 289-298.
7. Denko, M.K. and J. Tian, 2008. "Cross-Layer Design for Cooperative Caching in Mobile Ad Hoc Networks," in *2008 5th IEEE Consumer Communications and Networking Conference*, pp: 375-380.
8. Atsan, E. and Ö. Özkasap, 2013. "SCALAR: Scalable data lookup and replication protocol for mobile ad hoc networks," *Comput. Networks*, 57(17): 3654-3672.
9. Amirian, P. and A.A. Alesheikh, 2008. "A Service Oriented Framework for Disseminating Geospatial Data to Mobile, Desktop and Web Clients," *World Appl. Sci. J.*, 3(1): 140-153.
10. Reed, G., R. Keeley, S. Belov, N. Mikhailov and A. Ocean, 2010. "OCEAN DATA PORTAL?: A Standards Approach to Data Access AND," in *Proceedings of the "OceanObs, 9. 2010*, pp: 1.
11. Shimrat, O., 2009. "Cloud Computing and Healthcare," *San Diego Physician.org*. pp: 26-29.
12. Antony, N. and A.A.R. Melvin, 2013. "An Efficient Approach For Flexible And Scalable Access Control Through HASBE," *Int. J. Comput. Sci. Manag. Res.*, 2(4): 2003-2007.
13. Ontrack, K., 2010. "Maximize Accessibility and Minimize the Risk Stored in Your Enterprise Data," *The Data Accessibility Gamble?: What is Your Enterprise Wagering??* pp: 1-12.
14. Nakao, M., S. Okamoto, M. Kohara, T. Fujishiro, T. Fujisawa, S. Sato, S. Tabata, T. Kaneko and Y. Nakamura, 2010. "CyanoBase: the cyanobacteria genome database update 2010." *Nucleic Acids Res.* vol. 38, no. Database issue, pp: D379-81.
15. Alboaie, L., D. Gorea and V. Felea, 2008. "Semantic Integrity Control in the Database Layer of an e-Health System Functional and architectural perspective of Telemon e-health system," *Int. J. Comput. Commun. Control*, vol. III, no. Proceedings of ICCCC, pp: 162-167.
16. Topac, V. and V. Stoicu-Tivadar, 2011. "Patient empowerment by increasing information accessibility in a telecare system." *Stud. Health Technol. Inform.* 169: 681-5.
17. Purnama, B.E. and S. Hartati, 2012. "Convenience and Medical Patient Database Benefits and Elasticity for Accessibility Therapy in Different Locations," *Int. J. Adv. Comput. Sci. Appl.*, 3(9): 54-60.
18. Doukas, C., T. Pliakas and I. Maglogiannis, 2010. "Mobile healthcare information management utilizing Cloud Computing and Android OS." in *Engineering in Medicine and Biology Society (EMBC), 2010 Annual International Conference of the IEEE, 2010*, pp: 1037-1040.
19. Rolim, C.O., F.L. Koch, C.B. Westphall, J. Werner, A. Fracalossi and G.S. Salvador, 2010. "A Cloud Computing Solution for Patient's Data Collection in Health Care Institutions," in *2010 Second International Conference on eHealth, Telemedicine and Social Medicine, 2010*, no. i, pp: 95-99.
20. Rumbold, B., G. Lewis and M. Bardsley, 2011. "Access to person-level data in health care," no. August. pp: 1-16.
21. Rahim, Y.A., S. Sahib and M.K.A. Ghani, 2011. "Pseudonymization techniques for clinical data: Privacy study in Sultan Ismail Hospital Johor Bahru," in *7th International Conference on Networked Computing*, pp: 74-77.

22. Badurowicz, M., 2012. "Two-dimensional barcodes in mobile applications," in *Actual Problems of Economics*, 132: 346-350.
23. Shiang-yen, T.A.N., L.Y. Foo and R. Idrus, 2010. "Application of Quick Response (QR) Codes in Mobile Tagging System for Retrieving Information about Genetically Modified Food," in *Proceedings of the 9th WSEAS international conference on Data networks, communications, computers, DNCOCO*, pp: 114-118.
24. Becker C. and C. Bizer, "DBpedia Mobile?: A Location-Enabled Linked Data Browser," pp: 6-7.
25. Brooks, R., "13 Creative Ways to Use Qr Codes for Marketing," 2011. [Online]. Available: <http://www.fastcompany.com/1720193/13-creative-ways-use-qr-codes-marketing>.
26. Limpag, M., 2013. "Leon Kilat?: The Tech Experiments Use QR codes, Google Docs to set up free inventory system Related posts?:" max.limpag.com, 2013. [Online]. Available: <http://max.limpag.com/article/qr-code-google-docs-inventory>.
27. Zainuddin, M., D. Baswaraj and S.M. Riyazoddin, 2012. "Generating SMS (Short Message Service) in the form of Quick Response Code (QR-code)," *J. Comput. Sci. Inf. Technol.*, 1(1): 10-14.
28. Murkute, J., H. Nagpure, H. Kute and N. Mohadikar, 2013. "Online Banking Authentication System Using QR-code and Mobile OTP," *Int. J. Eng. Res. Appl.*, 3(2): 1810-1815.
29. So, S., 2010. "Beyond the simple codes?: QR codes in education," in *In Ascilite Conference Changing Demands, Changing Directions*, pp: 1157-1161.
30. Patil, A., A. Patil, M. Raman and M. Singh, 2013. "MCQ Based Exam Using QR Code," *Int. J. Comput. Sci. Manag. Res.*, 2(4): 2206-2210.
31. Huang, W., K. Wu and M. Chen, 2011. "The Study of Using QR Code in the Mobile Tourist Guide Map," in *e-CASE & e-Tech International Conference*, pp: 2976-2987.
32. Dolan, P.L., 2011. "The latest health care marketing tool?: QR codes," *American Medical News*,
33. Charlton, G., 2011. "The pros and cons of QR codes," *Econsultancy*, [Online]. Available: <http://econsultancy.com/my/blog/7884-the-pros-and-cons-of-qr-codes>.