

# Simulation Single Phase Shunt Active Filter Based on p-q technique using MATLAB/Simulink Development Tools Environment

Musa Yusup Lada\*, Othman Mohindo\*\*, Aziah Khamis\*\*, Jurifa Mat Lazi\*\*, Irma Wani Jamaludin\*\*

\*Universiti Teknikal Malaysia Melaka/FKE, Durian Tunggal, Melaka. Email: musayl@utem.edu.my

\*\*Universiti Teknikal Malaysia Melaka/FKE, Durian Tunggal, Melaka, Malaysia.

**Abstract** – This paper presents a single phase shunt active power filter based on instantaneous power theory. The active filter will be connected directly to utility in order to reduce THD of load current, in this case the utility is TNB. The instantaneous power theory also known as p-q theory is used for three phase active filter and this paper proves that the p-q theory can also be implemented for single phase active filter. Since the system has only single phase signal for both voltage and current, thus the dummy signal with 120° different angles must be generated for input of the p-q theory. The p-q technique will generate six signals PWM for switching IGBT, but only two of the signals will be used to control the switching IGBT. The simulation results are on MATLAB/Simulink environment tools presented in order to demonstrate the performance of the current load on single phase shunt active power filter.

**Keywords** - Shunt Active Power Filter, Total Harmonic Distortion, Instantaneous Power Theory,

## I. Introduction

Increasing demand on power converter or others non-linear load will cause usage of active power filter which widely applied eliminates the total harmonic distortion of load current. By generating harmonic that came from non-linear load, will facing a serious problem in the power system such as low power factor, increases losses, reduces the efficiency and increase the total harmonic distortion. The instantaneous power theory or p-q theory was introduced by Akagi, Kanazawa and Nabae in 1983 [1], [2]. The p-q theory was introduced and implemented only for three phase power system as shows in Fig. 1. Based on the term of p and q, the p-q theory will manipulate the

active and reactive power in order to maintain the purely sinusoidal current waveform at three phase power supply.

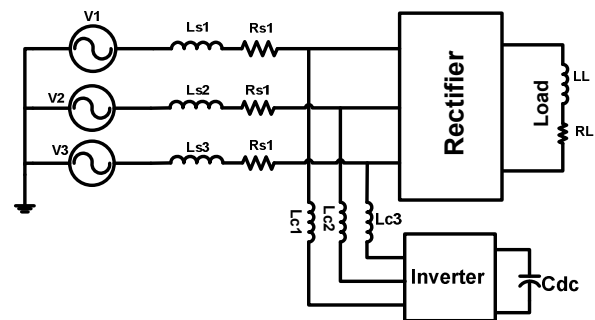

Fig. 1: Three phase active filter

There are a few techniques which can be used to eliminate harmonic others than active filter namely: L-C filter and Zig-Zag transformer. These techniques facing many disadvantage either the controller or the system such as fixed compensation, possible resonance, bulkiness, electromagnetic interference, voltage sag and flicker [1-6].

There are some advantages of implementing shunt active filter on grid power system since it can be installed at housing estate or others system that using single phase grid power system. The aim of this paper is to implement the p-q theory in single phase shunt active filter connected directly to grid power system. The technique is simulated by using MATLAB/Simulink simulation development tools environment.

## II. Mathematical Model

The p-q theory also known as instantaneous power theory is widely used for three wires three phase power system and also extended to four wires three phase power system. Although this theory using three current and three voltage signals, it also can be used for single phase active filter by duplicating two more current and voltage signal with 120° angel shifting. This theory based on separation power component separation in mean and oscillating values. Consider load current of single phase load as phase “a” and others phase (phase “b” and phase “c”) are generated by duplicating technique. The load current can be assumed as phase “a” current and with be expressed mathematically as shows in eq. (1). By assuming that eq. (1) as phase “a” load current, load current for phase “b” and c can be represented as eq. (2) and eq. (3).

$$i_a = \sum_{i=0}^n \sqrt{2} I_i \sin(\omega_i + \theta_i) \quad (1)$$

$$i_b = \sum_{i=0}^n \sqrt{2} I_i \sin(\omega_i + \theta_i - 120^\circ) \quad (2)$$

$$i_c = \sum_{i=0}^n \sqrt{2} I_i \sin(\omega_i + \theta_i + 120^\circ) \quad (3)$$

Equation (1), (2) and (3) can be transformed in matrix form as shown in (4) and (5) for load current and load voltage respectively:

$$\begin{bmatrix} i_a \\ i_b \\ i_c \end{bmatrix} = \begin{bmatrix} 1 \\ 1\angle 120^\circ \\ 1\angle 240^\circ \end{bmatrix} \begin{bmatrix} i_a \end{bmatrix} \quad (4)$$

$$\begin{bmatrix} v_a \\ v_b \\ v_c \end{bmatrix} = \begin{bmatrix} 1 \\ 1\angle 120^\circ \\ 1\angle 240^\circ \end{bmatrix} \begin{bmatrix} v_a \end{bmatrix} \quad (5)$$

Determine the  $\alpha$  and  $\beta$  reference current by using Clarke transformation as shown in (6) for load current and in (7) for load voltage.

$$\begin{bmatrix} i_\alpha \\ i_\beta \\ i_o \end{bmatrix} = \sqrt{\frac{2}{3}} \begin{bmatrix} 1 & -\frac{1}{2} & -\frac{1}{2} \\ 0 & \frac{\sqrt{3}}{2} & -\frac{\sqrt{3}}{2} \\ \frac{1}{\sqrt{2}} & \frac{1}{\sqrt{2}} & \frac{1}{\sqrt{2}} \end{bmatrix} \begin{bmatrix} i_a \\ i_b \\ i_c \end{bmatrix} \quad (6)$$

$$\begin{bmatrix} v_\alpha \\ v_\beta \\ v_o \end{bmatrix} = \sqrt{\frac{2}{3}} \begin{bmatrix} 1 & -\frac{1}{2} & -\frac{1}{2} \\ 0 & \frac{\sqrt{3}}{2} & -\frac{\sqrt{3}}{2} \\ \frac{1}{\sqrt{2}} & \frac{1}{\sqrt{2}} & \frac{1}{\sqrt{2}} \end{bmatrix} \begin{bmatrix} v_a \\ v_b \\ v_c \end{bmatrix} \quad (7)$$

The active and reactive power is written as:

$$p = v_\alpha i_\alpha + v_\beta i_\beta + v_o i_o \quad (8)$$

$$q = v_\alpha i_\alpha - v_\beta i_\beta \quad (9)$$

$$\begin{bmatrix} p \\ q \end{bmatrix} = \begin{bmatrix} v_\alpha & v_\beta \\ -v_\beta & v_\alpha \end{bmatrix} \begin{bmatrix} i_\alpha \\ i_\beta \end{bmatrix} \quad (10)$$

Active power and reactive power consist of two part which are mean part and oscillating part also known as DC part and AC part. The equations of active power and reactive power can be given as:

$$p = \bar{p} + \tilde{p} \quad (11)$$

$$q = \bar{q} + \tilde{q} \quad (12)$$

The DC part can be calculated by using low-pass filter, which is can remove the high frequency and give the fundamental component or the DC part. From DC part active power and reactive power, the  $\alpha$ - $\beta$  reference current can be represented in (13).

$$i_{\alpha\beta} = \frac{1}{\Delta} \begin{bmatrix} v_\alpha & v_\beta \\ v_\beta & -v_\alpha \end{bmatrix} \begin{bmatrix} p \\ q \end{bmatrix} \quad (13)$$

$$\text{Where } \Delta = v_\alpha^2 + v_\beta^2$$

The three phase current reference of active power filter is given in (14) before the signal will subtracted to load current. The subtracted three phase current will be used to

generated PWM signal using hysteresis band. Hysteresis band will produce six PWM signals and for single phase active filter it is only two are used as input of hysteresis band.

$$i_{abc}^* = \sqrt{\frac{2}{3}} \begin{bmatrix} 1 & 0 \\ -\frac{1}{2} & \frac{\sqrt{3}}{2} \\ -\frac{1}{2} & -\frac{\sqrt{3}}{2} \end{bmatrix} i_{\alpha\beta}^* \quad (14)$$

### III. Single Phase Shunt Active Filter

Single phase shunt active filter consists of supply utility single phase, single phase rectifier, single phase active filter, controller and load. Schematic of single phase shunt active filter is shown in Fig. 2. They are two kinds of active power filter such as current source active filter and voltage source active filter. The different between these two topologies is the storage element. Current source active filter will use inductance as the storage element mean while voltage source active filter use capacitance as the storage element.

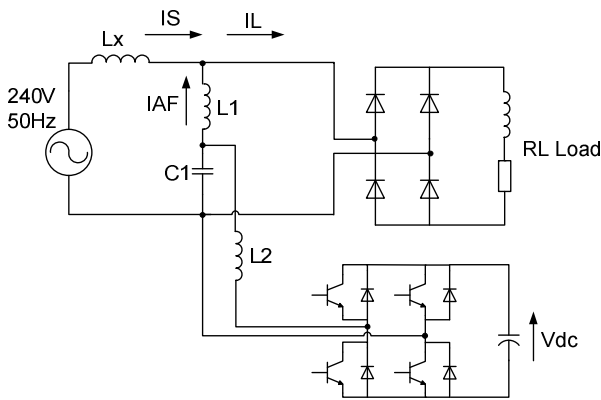

Fig. 2: Schematic diagram of single phase shunt active filter

Fig. 3 shows the control strategy based on p-q theory that is used to generate PWM signal for single phase shunt active filter. The simulation of single phase shunt active

filter uses this control strategy on MATLAB/ Simulink software.

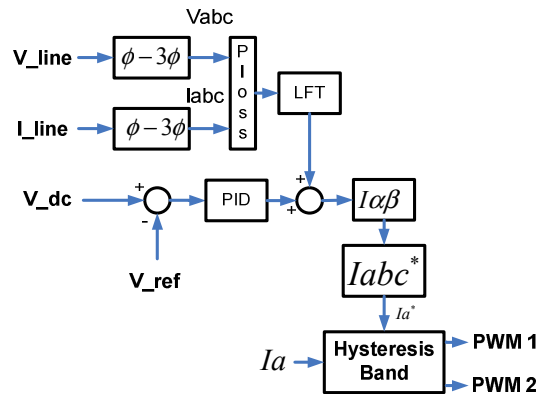

Fig. 3: Control strategy

### IV. Simulation Result

A simulation of single phase shunt active filter is simulated using MATLAB/Simulink. The simulation use single phase system 240V 50Hz directly from TNB as shows in Fig. 4. The non-linear load with 3KVA for compensation is connected before single phase diode rectifier.

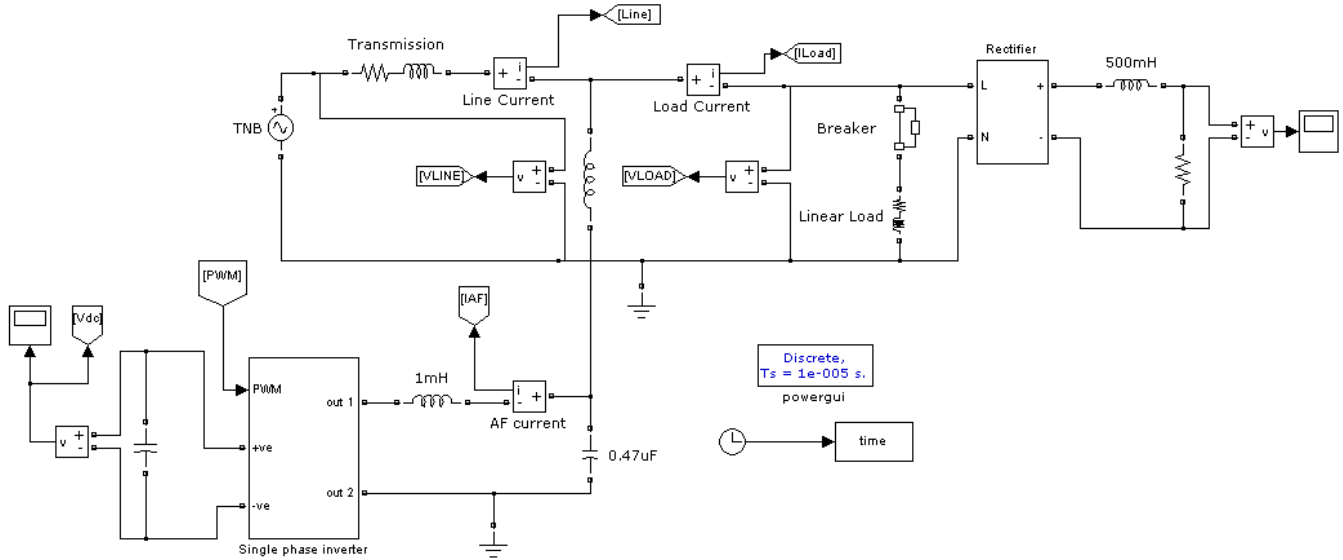

Fig. 4: Modelling of single phase active filter

Fig. 5 shows the modelling of p-q theory which consists of single to three phase block, algebra transformation of p-q theory three phase to two phase, two phase to three phase transformation and hysteresis band. Hysteresis band will produce six signals PWM and for single phase active filter only use two signals to control the single phase active filter.

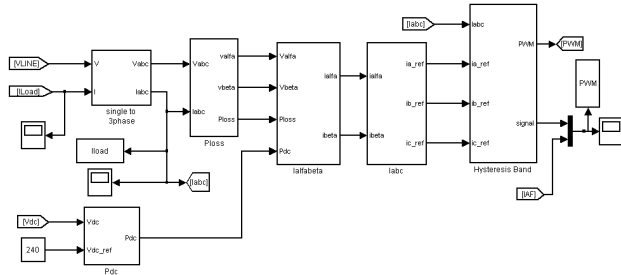

Fig. 5: Modelling of p-q theory

Current response for single phase active filter is shown in Fig. 6. The switching PWM signal and the active filter current are shown in Fig. 7. The load current in Fig. 8 will be compensated by injecting active filter current as shown in Fig. 9, so that the line current will be kept maintain in purely sinusoidal form as shown in Fig. 10. Fig. 11 shows the three phase load current that will be used for p-q theory application.

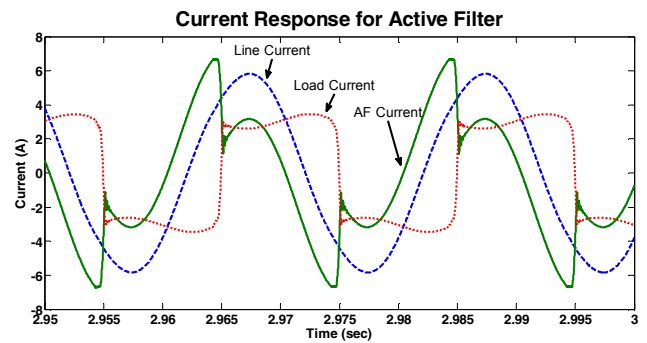

Fig. 6: Current response for single phase active filter

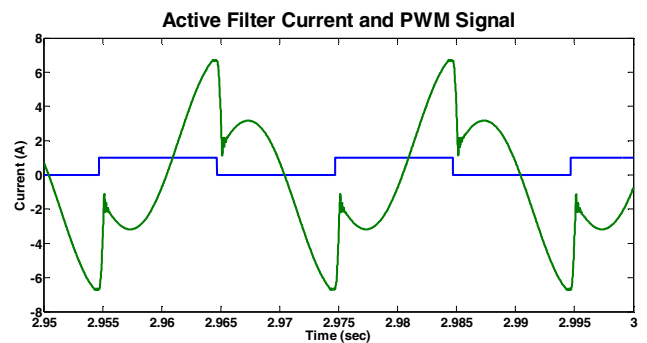

Fig. 7: Active filter current and PWM signal

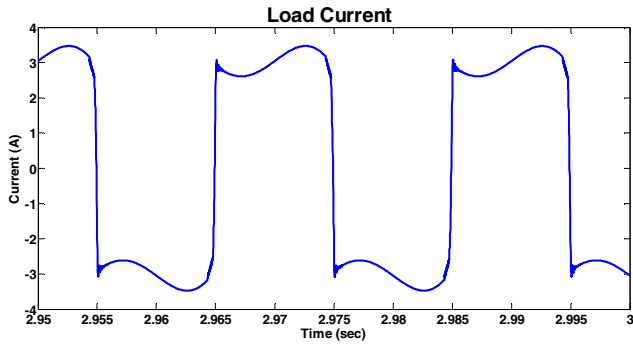

Fig. 8: Load current

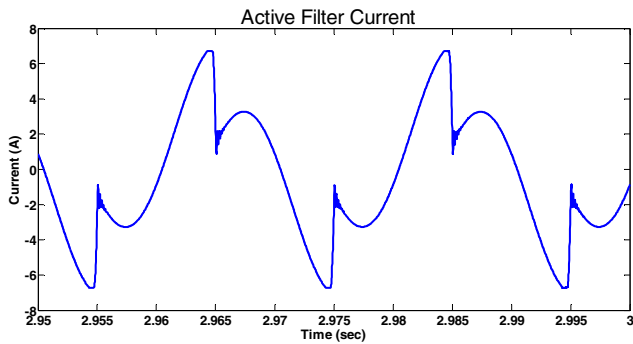

Fig. 9: Active filter current

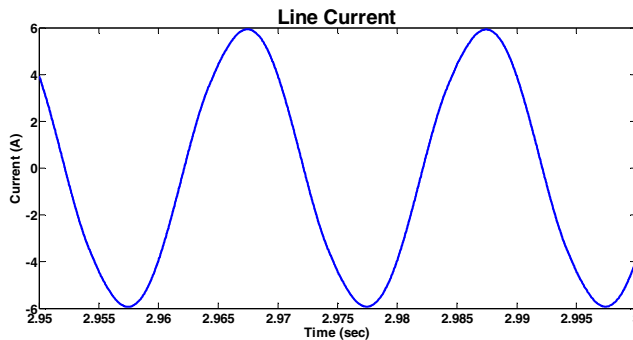

Fig. 10: Line current

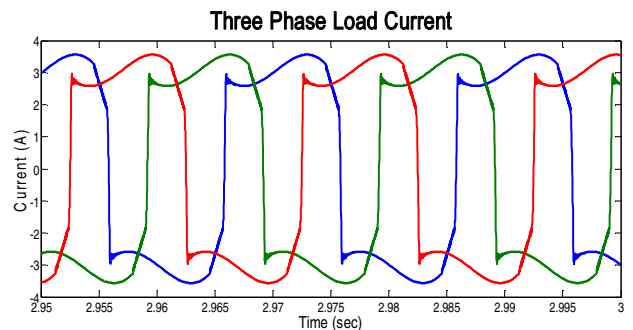

Fig. 11: Three phase load current

The effected non-linear load of the system will make the THD of load current increase up to 44.92% as shown in Fig. 12. By injecting the active filter current the THD of line current will reduce to 2.85% as shown in Fig. 13.

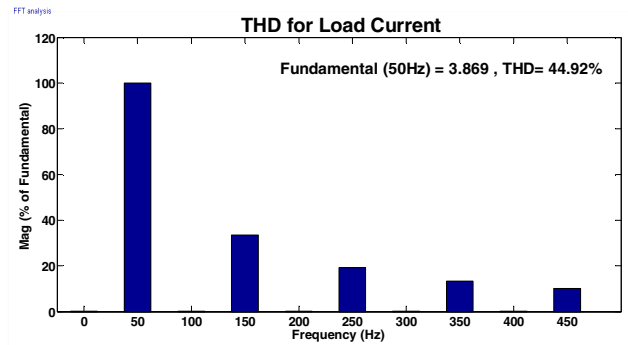

Fig. 12: THD for load current

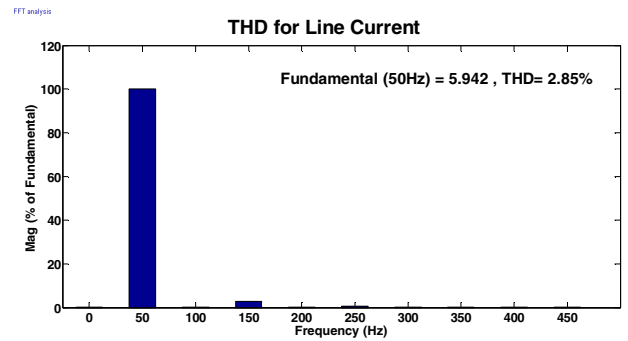

Fig. 13: THD for line current

## V. Conclusion

In recent years the increasing usages of non-linear load facing of harmonic and power factor problem in power system. Many technique or topologies can be used to eliminate harmonics from power system; one of the techniques is active power filter. This paper proves that p-q theory can be implemented to control single phase active filter, which the theory widely used to control three phase active power filter. It is discovered from simulation that by implemented the p-q theory the THD of the load current can be reduced from 44.92% to 2.85%.

## References

- [1] A. Emadi, A. Nasiri, and S. B. Bekiarov, *Uninterruptible power supplies and active filters*: CRC, 2005.
- [2] H. Akagi, E. H. Watanabe, and M. Aredes, *Instantaneous power theory and applications to power conditioning*: Wiley-IEEE Press, 2007.
- [3] N. A. Rahim, S. Mekhilef, and I. Zahrul, "A single-phase active power filter for harmonic compensation," *Industrial Technology. IEEE International Conference*, 2006, pp. 1075-1079.
- [4] K. Ryszard, S. Boguslaw, and K. Stanislaw, "Minimization of the source current distortion in systems with single-phase active power filters and additional passive filter designed by genetic algorithms," *Power Electronics and Applications, European Conference*, 2006, p. 10.
- [5] D. W. Hart, *Introduction to power electronics*: Prentice Hall PTR Upper Saddle River, NJ, USA, 1996.
- [6] M. McGranaghan, "Active filter design and specification for control of harmonics in industrial and commercial facilities," Knoxville TN, USA: Electrotek Concepts, Inc., 2001.
- [7] S. Round, H. Laird, R. Duke, and C. Tuck, "An improved three-level shunt active filter." vol. 1: *Power Electronic Drives and Energy Systems for Industrial Growth International Conference*, 2004, pp. 87-92.
- [8] H. Lev-Ari and A. M. Stankovic, "Hilbert space techniques for modeling and compensation of reactive power in energy processing systems." vol. 50: *IEEE Transactions on Circuits and System Part 1: Regular Papers*, 2003, pp. 540-556.
- [9] A. Emadi, "Modeling of power electronic loads in ac distribution systems using the generalized state-space averaging method." vol. 51: *IEEE Transactions on Industrial Electronics*, 2004, pp. 992-1000.
- [10] J. Afonso, C. Couto, and J. S. Martins, "Active filters with control based on the pq theory," *IEEE Industrial Electronics Society newsletter*. ISSN 0746-1240. 47:3, 2000.
- [11] C. Cai, L. Wang, and G. Yin, "A three-phase active power filter based on park transformation," *Nanning Computer Science & Education 2009. 4th International Conference*, 2009, pp. 1221-1224.
- [12] M. George and K. P. Basu, "Three-Phase Shunt Active Power Filter." vol. 5: *American Journal of Applied Sciences*, 2008, pp. 909-916.