

# Transformation of Generalized Chebyshev Lowpass Filter Prototype to Suspended Stripline Structure Highpass Filter for Wideband Communication Systems

Z. Zakaria<sup>1</sup>, M. A. Mutalib<sup>2</sup>, M. S. Mohamad Isa<sup>3</sup>, N. A. Zainuddin<sup>4</sup>

Centre of Telecommunication Research and Innovation (CeTRI), Faculty of Electronic and Computer Engineering,  
Universiti Teknikal Malaysia Melaka (UTeM), Hang Tuah Jaya 76100, Durian Tunggal, Melaka, Malaysia

<sup>1</sup>zahriladha@utem.edu.my, <sup>2</sup>arifinmutalib@gmail.com, <sup>3</sup>saari@utem.edu.my, <sup>4</sup>nuraishah.zainuddin@yahoo.com

**Abstract**—This paper presents the transformation of generalized Chebyshev lowpass filter prototype to highpass filter using Suspended Stripline Structure (SSS) technology. The study involves circuit analysis to determine generalized Chebyshev responses with a transmission zero at finite frequency. The transformation of the highpass filter from the lowpass filter prototype provides a cutoff frequency of 3.1 GHz with a return loss better than -20 dB. The design is simulated on a Roger Duroid RO4350 with a dielectric constant,  $\epsilon_r$ , of 3.48 and a thickness of 0.168 mm. The simulation performance results show promising results that could be further examined during the experimental works. This class of generalized Chebyshev highpass filter with finite transmission zero would be useful in any RF/ microwave communication systems particularly in wideband applications where the reduction of overall physical volume and weight as well as cost very important, while maintaining its excellent performance

**Keywords**—Microwave filter, highpass filter (HPF), Suspended Stripline Structure (SSS),

## I. INTRODUCTION

With the fast development of wireless communication, microwave filters with characteristics of high performance, low-cost, low insertion loss (IL) and compact are highly desirable for the next generation wireless communication system. Filter design starts with a classical lowpass lumped-element equivalent circuit or prototype. The equivalent circuit consists of series and shunt inductance and capacitor and their combination to form either series or parallel resonators [1][2][3]. The main advantage of generalized Chebyshev is mathematically can place a finite frequency at the location of two transmission zeros. Moreover it produces a good selectivity and enhances the filter's performance [4].

A microstrip ring resonator with stubs is studied in [5] to design a wideband filter by utilizing its first three resonant modes. However, a lack of strength in capacitive coupling between the feeding-lines and ring, made the filter unable to produce a good response with wide bandwidth. The compact suspended stripline resonator is present in [6] which produce a

microwave filter by using resonator. This design has increased the capacitive loading of the resonator but it is difficult to control the return loss below than -20 dB. In [7], the filter is design using optimum distributed short circuited stubs method. However, this design did not produce narrow curve rejection at insertion loss.

In this paper, the transformation of generalized Chebyshev from the lowpass filter prototype to highpass filter is presented. As proof of concept, the highpass filter is designed at a cutoff frequency of 3.1 GHz with minimum stopband insertion loss of 40 dB at 2.5 GHz and minimum passband return loss of -20dB. The performance of generalized Chebyshev characteristic is better that the conventional Chebyshev particularly in term of its selectivity due to the transmission zeros can be placed at desired finite frequency. Thus, the generalized Chebyshev reduces the number of elements used in prototype and subsequently reducing the overall circuit dimensions. The filter design is designed based on suspended stripline structure (SSS) to exhibit a pure transverse electric-magnetic (TEM) mode of propagation and resulting in very low loss characteristics and excellent selectivity. The design has very sharp rejection which easier to determine the minimum stopband insertion loss.

## II. DESIGN OF LOWPASS FILTER

The generalized Chebyshev has equal ripple response in passband but with arbitrary placed transmission zeros in the stopband offering selectivity nearly as well as the same degree elliptic filter. Generalized Chebyshev filter prototype is more preferred due to the transmission zeros can be set independently as accordance to design specification. Alesyab in [8] synthesize the element values for generalized Chebyshev low pass filter prototype which can be used to transform into any filter response. The doubly terminated low-pass prototype network satisfies the insertion-loss (IL) for the generalized Chebyshev response as described by:

$$|L| = 1 + \epsilon^2 \cosh^2 \left\{ (N-3) \cosh^{-1} \left[ \omega \left( \frac{\omega_0^2 - 1}{\omega_0^2 - \omega^2} \right)^{1/2} \right] + 3 \cosh^{-1} \omega \right\} \quad (1)$$

where the transmission zeros are based on order  $(n-1)$  at  $\omega = \pm\omega_0$  and one at infinity.  $N$  is an odd number equal to the degree of the network,

$$\epsilon = [10^{(RL/10)} - 1]^{-1/2} \quad (2)$$

and  $RL$  is the minimum return loss level (dB) in the passband.

### III. DESIGN OF HIGHPASS FILTER

#### A. Transformation Lowpass Filter Prototype to Highpass Filter

In this section, a systematic filter development using the lowpass filter prototypes as a starting point will be demonstrated. A dual type of the generalized Chebyshev lowpass prototype filter is used as described in Section II. This dual type of lowpass prototype will satisfy the generalized Chebyshev with three transmission zeroes. The transformation to highpass filter is given by [9].

$$\omega \rightarrow \frac{-\omega_c}{\omega} \quad (3)$$

where  $\omega_c$  is cutoff frequency

This maps the lowpass filter prototype cutoff frequency to a new frequency. The transformation is applied to inductors and capacitors, where

$$C' = \frac{1}{\omega_c L} \quad (4)$$

$$L' = \frac{1}{\omega_c C} \quad (5)$$

Hence the inductors are transformed into capacitors and capacitors are transformed into inductors as shown in Figure 1. The component values of the prototype highpass filter are shown in Table I.

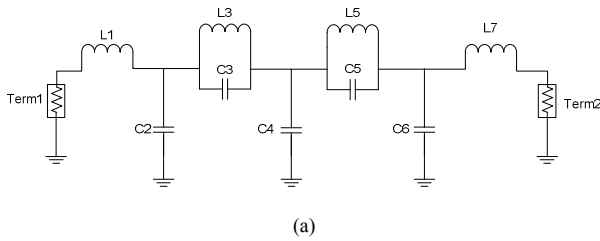

Figure 1: Seventh-degree generalized Chebyshev highpass filter prototype network

TABLE I: COMPONENT VALUE FOR PROTOTYPE LUMPED ELEMENTS

Elements of LPF	Value	Elements of HPF	Value
$L_1 = L_7$	1.02647	$C_1 = C_7$	0.97421
$C_2 = C_6$	1.08027	$L_2 = L_6$	0.92569
$L_3 = L_5$	0.541922	$C_3 = C_5$	0.90904
$C_3 = C_5$	1.10006	$L_3 = L_5$	1.84528
$C_4$	0.984147	$L_4$	1.01610

#### B. Impedance and frequency transformation

To verify the theory, the device is constructed using Roger RO4350 with relative dielectric constant,  $\epsilon_r = 3.48$ , substrate height,  $h = 0.168$  mm. The thickness of copper 0.035 mm and the loss tangent is 0.019. The highpass filter with cut-off frequency of 3.1 GHz with the degree,  $N = 7$ , the minimum stopband insertion loss of -40 dB at 2.6 GHz and minimum passband return loss of -20 dB are designed using the equation shown in (1) and (2). The elements values for the lowpass prototype network show in Table I with its corresponding  $\omega_0 = 1.29516$  rad/s can be obtained in [8].

The next step is to perform the impedance scaling with 50  $\Omega$ . After scaling to 50  $\Omega$  the values of the equivalent circuit for each lumped component are shown in Table II

TABLE II: COMPONENT VALUE OF LUMPED ELEMENTS

Elements	Value
$C'_1 = C'_7$	1.0003 pF
$L'_2 = L'_6$	2.3763 nH
$C'_3 = C'_5$	1.02619 pF
$L'_3 = L'_5$	4.7368 nH
$L'_4$	2.6084 nH

The highpass filter circuit can now be simulated using the Advance Design System (ADS) as seen in Figure 2 (a) and the response is shown in Figure 2 (b). It is observed that the filter has a cutoff frequency of 3.1 GHz which are in excellent agreement with the design specification.

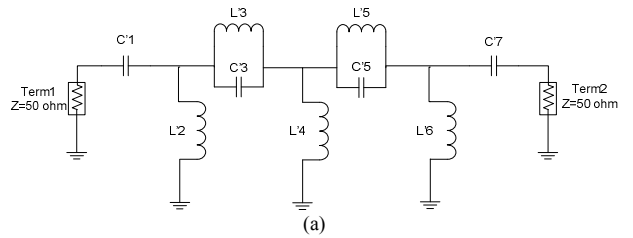

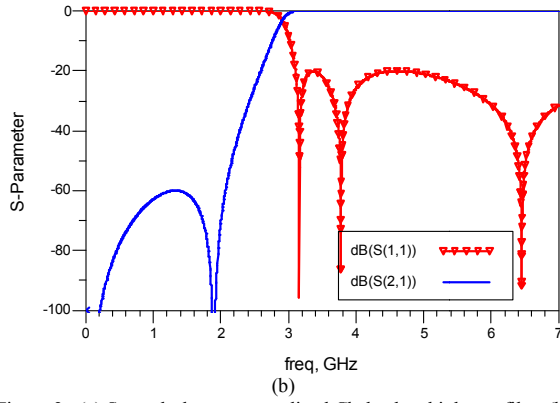

Figure 2 : (a) Seventh-degree generalized Chebyshev highpass filter (b) Simulated frequency response of the generalized Chebyshev highpass filter

C. Physical Realization of Highpass filter

For realization, the lumped element highpass filter is then transformed to open- and short-circuit transmission line segments by applying Richard’s transformation. Generalized Chebyshev highpass filter distribution can be constructed by applying Richard’s transformation to the highpass filter prototype in Figure 1. Under this transformation, inductor is transformed into an open-circuited stubs with admittances

$$Y_o = \frac{\alpha}{L_r} \tag{6}$$

and the resonator in the prototype has an impedance

$$Z(j\omega) = j\omega L_r - \frac{j}{\omega C_r} \tag{7}$$

The Richard’s transformation allows to replace lumped inductors with short circuited stubs of characteristic impedance  $Z_o = L$  and capacitors with open circuited stubs of characteristic impedance  $Z_o = 1/C$ . The resonator impedance can be represented as admittance of an open circuited stub by characteristic admittance  $\alpha C/2$ .

The length of the stub is one quarter wavelength at  $\omega_0$ . Constant  $a$  can be obtained by applying Richard’s transformation at the band edge. The structure of distributed element after applying the Richard’s transformation is shown in Figure 3. The values of short- and open-circuit stubs are shown in Table III. The electrical length of  $30^\circ$  is decided to obtain a broader passband bandwidth.

TABLE III : ELEMENT VALUE OF STUB ELEMENT

Elements	Value	Elements	Value
Z1	29.4 $\Omega$	Z4	63.045 $\Omega$
Z2	290.68 $\Omega$	Z5	62.37 $\Omega$
Z3	42.12 $\Omega$	E1	30 $^\circ$

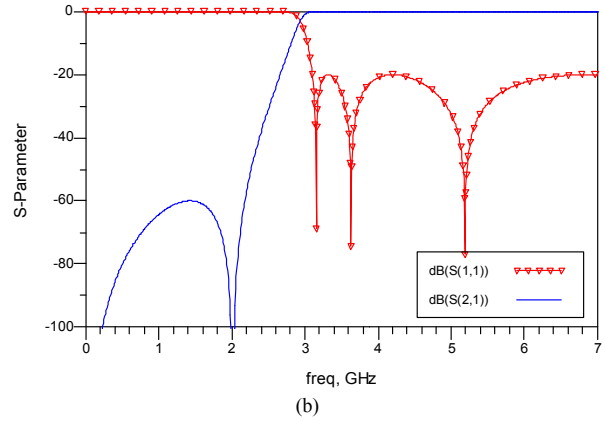
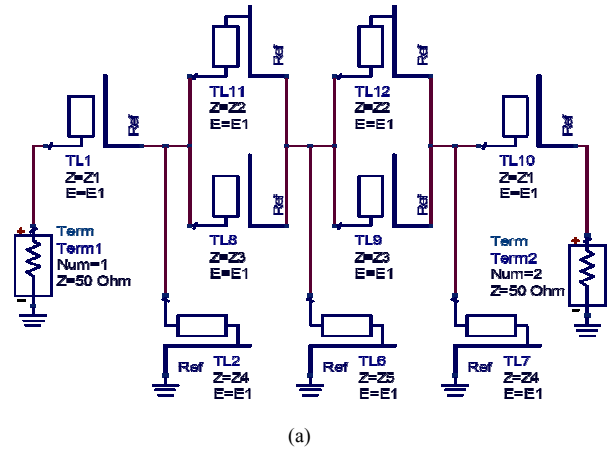

Figure 3 : (a) Generalized Chebyshev highpass distributed filter (b) Simulated frequency response of the generalized Chebyshev lowpass distributed filter

The simulated results show an insertion loss ( $S_{21}$ ) is almost 0 dB and return loss ( $S_{11}$ ) better than -20 dB are obtained in the passband. A transmission zero at finite frequency of 2.1 GHz is observed.

D. Suspended Stripline Structure (SSS)

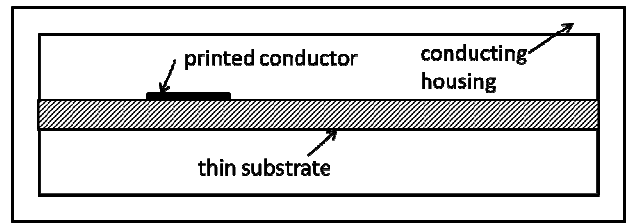

Figure 4 : Suspended Stripline Structure

This highpass filter is simulated using SSS (as shown in Figure 4) in order to improve the overall filter performance. The impedance of the SSS which is based on Transverse Electromagnetic (TEM) transmission line is related to its static capacitance to ground per unit length as the following [10]:

$$Z_0\sqrt{\epsilon_r} = \frac{377}{C/\epsilon} \quad (8)$$

where  $\epsilon_r$  is the dielectric constant of the medium and  $C/\epsilon$  is the normalized static capacitance per unit length of the transmission line. If a transmission line is suspended, the normalized static capacitance would include fringing capacitance.

$$\frac{C}{\epsilon} = 2C_p + \frac{4C'_f}{\epsilon} \quad (9)$$

and

$$C_p = \frac{w}{(b-t)/2} \quad (10)$$

For a printed circuit,  $t$  is assumed as zero and hence

$$\frac{C}{\epsilon} = \frac{4w}{b} + 1.84 \quad (11)$$

Therefore the line width can be obtained as:

$$w = \frac{b}{4} \left( \frac{377}{Z_0} - 1.84 \right) \quad (12)$$

where  $b$  is a ground plane spacing in mm and  $Z_0$  is characteristics of impedance line.

In order to realize the highpass filter layout, series capacitors and resonators can be approximated by inhomogeneous couple lined realized in suspended substrate. A series capacitance can be realized in the form of parallel coupled structure, overlapping of strips on the top and bottom layers of the substrate as shown in Figure 5.

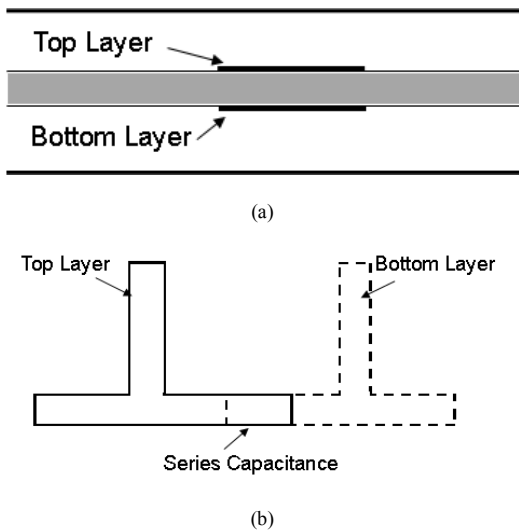

Figure 5 : Layout of highpass filter using series capacitance and open circuited shunt stubs (a) cross section (b) top view

To produce a wider bandwidth, the value of necessary impedance became too small to fabricate effect of line separation. This limitation can overcome in suspended

stripline where the larger impedance can be produced by using broadside-couple lines.

$$Z_0 = \frac{\eta_0}{\sqrt{\epsilon_e}} \left[ \frac{w}{h} + 1.393 + 0.667 \ln \left( \frac{w}{h} + 1.444 \right) \right]^{-1} \quad (13)$$

where

$$\epsilon_e = \frac{1}{2} [\epsilon_r + 1 + (\epsilon_r - 1)F] \quad (14)$$

and

$$F = \left( 1 + \frac{12h}{w} \right)^{-1/2} \quad (15)$$

$\epsilon_r$  is the relative dielectric constant of substrate and  $\eta_0$  is the wave impedance which is 377  $\Omega$ .

The series capacitors are represented by an overlapping line possessing capacitance  $C_s$ . The length overlaps is given by

$$l = \frac{1.8 u Z_{oo} C_s}{\sqrt{\epsilon_e}} \quad (16)$$

where  $u$  is the phase velocity and  $Z_{oo}$  is the odd mode impedance and is given by replacing  $h$  in (13) by  $h/2$ .

For the series resonators, the capacitance too can be represented by the length of overlapping lines and can be calculated from (13) and (16). The nearer distance between them means tighter coupling results in a better selectivity. The 3-D physical layout of the highpass filter is shown in Figure 6 (a). The current flow visualization of the physical layout is shown in Figure 6 (b). The SSS highpass is modeled, simulated and optimized using ADS Momentum and the simulated response are shown in Figure 6 (c). The results show an insertion loss ( $S_{21}$ ) is almost 0 dB and return loss ( $S_{11}$ ) better than -20 dB are obtained in the passband. There is a noted transmission zero occurs at around 3 GHz.

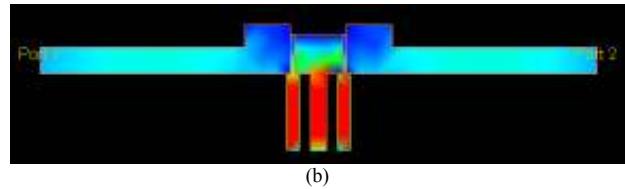
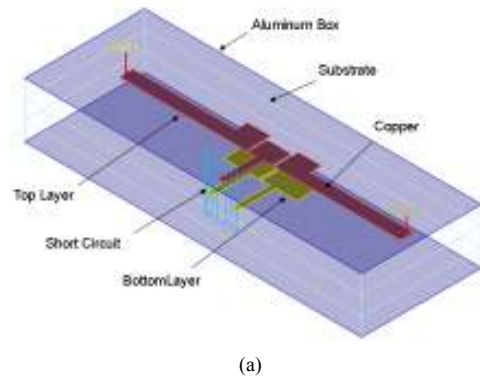

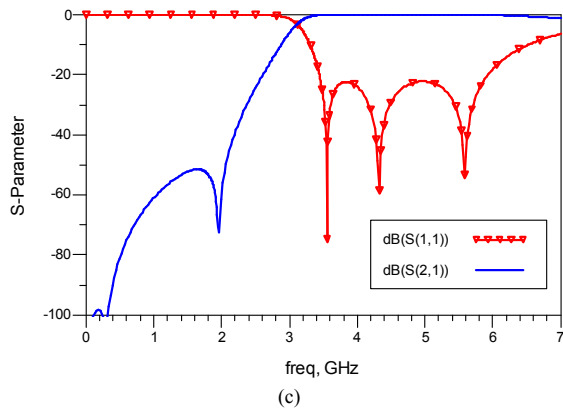

Figure 6 : (a) 3-D view of Generalize Chebyshev highpass filter (b) Momentum visualization of highpass filter (c) Simulated frequency response of the generalized Chebyshev highpass filter in suspended stripline structure

#### IV. CONCLUSION

A transformation of the generalized Chebyshev lowpass filter prototype to the highpass filter has been presented. Simulation result from EM simulation produce an excellent agreement with the ideal circuit. This study can be further explored by integrating the generalized Chebyshev lowpass filter and highpass filter based on SSS technology. This work can be simulated and fabricated in future work by cascading the lowpass filter and highpass filter to produce a bandpass filter characteristic. In addition, a defected stripline structure (DSS) can also be proposed to exhibit a sharp notch response in the integrated lowpass and highpass filter in order to remove the undesired signals in the wideband applications. This type of generalized Chebyshev characteristic which offers good selectivity is very useful to minimize the overall filter size because it requires a lesser number of elements in the circuit compared to conventional Chebyshev characteristic. Therefore, this new class of microwave filter would be useful in any microwave communication systems where the reduction of overall physical volume is very important while

still maintaining the good performance such as in ultrawide band (UWB) and radar applications.

#### ACKNOWLEDGMENT

The authors would like to thank UTeM for sponsoring this work under the short term grant, UTeM, PJP/2012/FKEKK(11C)/S01015.

#### REFERENCES

- [1] Z. Zakaria, I. C. Hunter, and A. C. Guyette, "Design of Coaxial Resonator Filter with Nonuniform Dissipation," IEEE MTT-S International Microwave Symposium Digest, pp. 623–626, 2008.
- [2] Z. Zakaria, B. H. Ahmad. Design of SIW Bandpass Filter with 6 dB Offset. IEEE RF and Microwave Conference (RFM), pp.87-90, 2011.
- [3] Z. Zakaria, A. Sabah, W. Y. Sam. Design of low-loss coaxial cavity bandpass filter with post-manufacturing tuning capabilities, IEEE Symposium on Business, Engineering and Industrial Applications (ISBEIA), pp. 733 – 736, 2012.
- [4] Z. Zakaria, M. A. Mutalib, K. Jusoff, M. S. Mohamad Isa, M. A. Othman, B. H. Ahmad, M. Z. A. Abd. Aziz, and S. Suhaimi, "Current Developments of Microwave Filters for Wideband Applications," World Applied Sciences Journal, vol. 21, pp. 31–40, 2013.
- [5] Sun, S. and Zhu, L. Wideband Microstrip Ring Resonator Bandpass Filters Undermultiple Resonances, IEEE Trans. On Microw. Theory and Tech., Vol. 55, No. 10, pp. 2176-2182, 2007.
- [6] R. Ruf and W. Menzel, "A Novel Compact Suspended Stripline Resonator," IEEE Microwave and Wireless Components Letters, vol. 22, no. 9, pp. 444–446, Sep. 2012.
- [7] S. K. Singhal, D. Sharma, and R. M. S. Dhariwal, "Design of 1.3 GHz Microstrip Highpass Filter Using Optimum Distributed Short Circuited Stubs," 2009 First International Conference on Computational Intelligence, Communication Systems and Networks, pp. 264–267, Jul. 2009.
- [8] S. A. Aloseyab, "A Novel Class of Generalized Chebyshev Low-Pass Prototype for Suspended Substrate Stripline Filters," IEEE Transactions on Microwave Theory and Techniques, vol. 30, no. 9, pp. 1341–1347, 1982.
- [9] C. Bowick, RF Circuit Design, Second. United State of America: Newnes, p. 256, 2007.
- [10] I. Hunter, Theory and Design of Microwave Filters. London, United Kingdom: The Institution of Engineering and Technology, 2001.