

Dual-Band Monopole Antenna For Energy Harvesting System

Z. Zakaria, N. A. Zainuddin, M. Z. A. Abd Aziz, M. N. Husain, M. A. Mutalib

Centre of Telecommunication Research and Innovation (CeTRI), Faculty of Electronic and Computer Engineering, Universiti Teknikal Malaysia Melaka (UTeM), Hang Tuah Jaya 76100, Durian Tunggal, Melaka, Malaysia

zahriladha@utem.edu.my, nuraishah.zainuddin@yahoo.com

Abstract—A planar dual-band monopole antenna is presented for Global System for Mobile Communications (GSM) band applications, which also have the potential to be used for energy harvesting system. The proposed antenna comprises of a ground plane at the back of the FR4 substrate and three microstrip lines which are physically connected with each other at the top surface of the substrate. The monopole antenna achieves good return loss at resonance frequencies of 915 MHz and 1800 MHz with a bandwidth value of 124.2 MHz and 196.9 MHz respectively. The antenna gains of 1.97 dB and 3.05 dB are achieved at resonance frequencies of 900 MHz and 1800 MHz. Experimental results show good agreement with simulated performance. The output from the receiving antenna is also observed in order to analyze the relationship of the power level and the distance between transmitting and receiving antenna. This study is an early investigation in designing the RF energy harvesting system to support green technology and sustainable development particularly for Wireless Sensor Network (WSN) applications.

Keywords—Dual-band; monopole; GSM band; return loss; gain

I. INTRODUCTION

Energy harvesting or energy scavenging is basically a conversion process of the ambient energy into electrical energy. In recent years, there has been a growing interest in the deployment of wireless sensor networks (WSN) that are used in applications such as in structural monitoring, habitat monitoring, healthcare systems and precision agriculture [1].

However, the deployment of a large number of sensor nodes results in periodic battery replacements which is impractical and costs consuming. One technique to overcome the aforementioned problems is to deploy a network comprising self-powered mechanisms through a Radio Frequency (RF) energy harvesting system [2]. This method significantly reduces the cost of replacing batteries periodically which also saves time.

An energy harvesting system consists of two main subsystems which are receiving antenna and rectification circuitry. Fig. 1 shows the basic block diagram of an energy harvesting system.

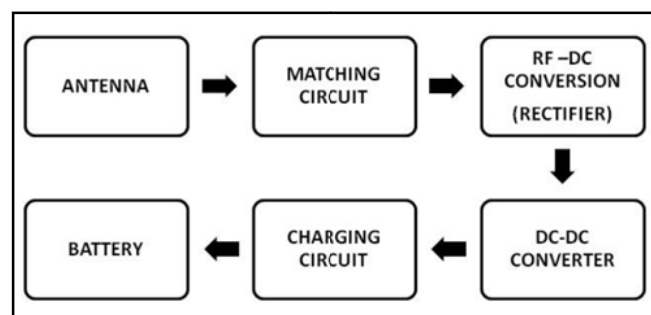

Fig. 1: Block diagram of energy harvesting system

It has been reported that the RF energy density in urban areas may be as high as $0.5\mu\text{W}/\text{cm}^2$. This corresponds to an input power level of $16.6\mu\text{W}$ or -17.6dBm at 1800MHz frequency [1]. Hence, an effort was made to convert the RF energy in the environment into electrical energy and use it for many applications such as powering mobile devices, wireless sensor networks or even to charge batteries [4]. An efficient antenna is needed to transfer wireless power efficiently. The antenna captures the RF signals from the ambient, and subsequently the rectifier circuit will extract the power from those signals and convert them into DC voltage.

It has been known that planar monopole antennas present interesting physical features such as simple structure, miniaturized, low cost and easy to fabricate. Additionally, planar monopole antennas are a compact broadband antenna which is not only omnidirectional radiated, but also non-dispersive [5].

Many efforts have been made in order to obtain planar shaped antennas which could provide wider bandwidth. Hence, a number of planar monopole antennas with different geometries have been experimentally characterized [6]-[11]. An optimum planar shaped antenna was achieved by developing new designing methods [12],[13].

Besides that, existence methods to improve the impedance bandwidth without modifying the geometry of the planar antenna are also investigated. This includes of adding a shorting post to the structure [14] and using two feeding points to excite the antenna [15].

In this paper, a new class of planar dual band monopole antenna based on three-microstrip lines structure for RF energy harvester is presented. Thus the antenna is recommended for

integration with matching and rectifying circuit to generate DC power.

II. ANTENNA DESIGN

The geometry of this planar dual-band monopole antenna consists of a ground plane (Layer 3) on the back of the substrate (Layer 2) and three connected microstrip lines labeled as A1, A2 and A3 on top of the substrate (Layer 1). These three connected microstrip lines act as the planar-monopole structure and share the same feeding point with the coaxial cable connector.

The antenna was simulated in FR4 substrate with dielectric constant of 4.4 and thickness of 1.6mm. While the microstrip line and the ground plane used material from the copper annealed with thickness of 0.035mm. The geometry of the planar monopole antenna is shown in Fig. 2.

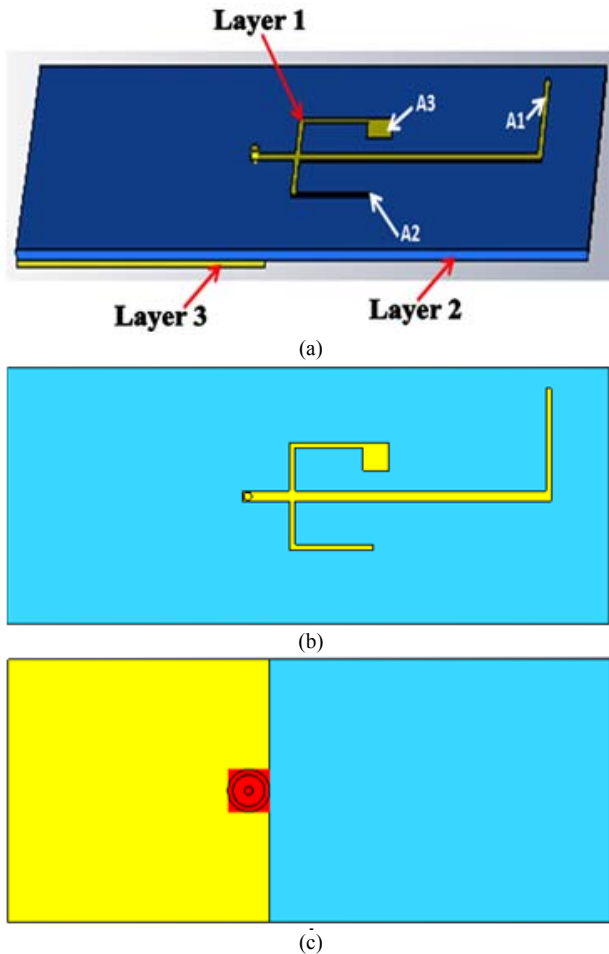

Fig. 2: Structure of planar dual-band monopole antenna
(a) Perspective view (b) Front view (c) Back view

The lengths and geometries of the three connected microstrip lines can be optimized to provide the required impedances for two frequency bands operation. For instance, the central microstrip line, A1 can provide impedance of 50 ohms at the lower frequency of 915 MHz while the two side arms, A2 and A3 can be optimized to provide required

impedance for 1800MHz frequency band. The antenna's dimensions are optimized by physical parametric studies.

III. EXPERIMENTAL RESULTS AND DISCUSSION

The antenna is then fabricated in-house and the photograph of the prototype can be seen in Fig. 3. An experimental measurement also has been made to validate the simulation results.

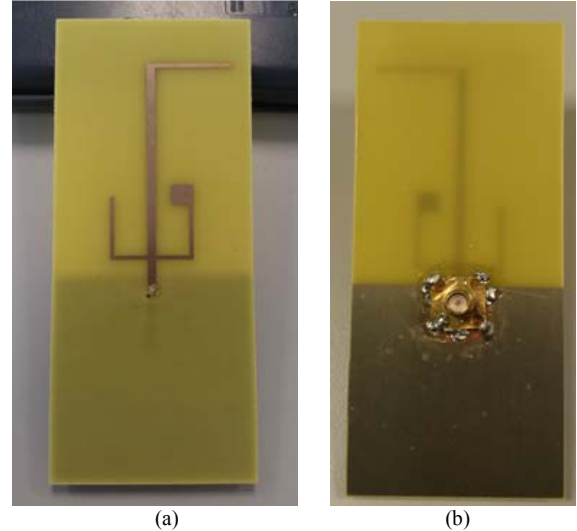

Fig. 3: Antenna prototype of planar dual-band monopole antenna (a) front view (b) back view

A. Return Loss, Bandwidth and Gain

S-parameter simulations of the antenna have been carried out using the Computer Simulation Tool (CST) 2011. Fig. 4 shows the simulated and measured return losses of the antenna.

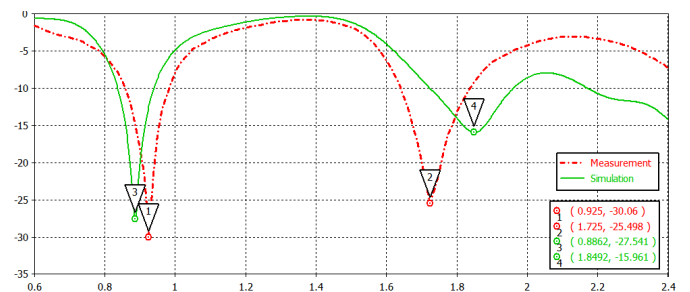

Fig. 4: Simulation and measured return loss of planar dual-band monopole antenna

The measured return loss is in line with the simulation response where both manage to achieve lower than -10 dB. However, measurement result shows better return loss than the simulated one but the resonant frequencies were slightly shifted.

From the measured data, two resonant modes at about 912.5 MHz and 1.70 GHz are successfully achieved. Table 1 shows the comparison of simulation and measurement result for the planar dual-band monopole antenna.

The gain parameter is measured by using the following equation;

$$\text{Gain Received} = P_R - P_T - G_T + L_P + L_{C1} + L_{C2} \quad (1)$$

Where P_R = power received; P_T = power transmit; G_T = gain transmit; L_P = path loss; and L_C = cable loss. The path loss is determined using Eq. 2.

$$L_P = 32.45 + 20 \log f(\text{MHz}) + 20 \log d (\text{km}) \quad (2)$$

The variable f denotes the frequency of interest in MHz while d denotes the distance between transmitting and receiving antenna in kilometers.

TABLE I. SIMULATION AND MEASUREMENT RESULT OF PLANAR DUAL-BAND MONOPOLE ANTENNA

Freq. of interest	f_r	Return Loss (dB)	Bandwidth (MHz)	Gain (dB)
915 MHz	Sim. 886 MHz	-27.54	102.7	1.97
	Meas. 925 MHz	-30.06	124.2	-1.64
1800 MHz	Sim. 1.85 GHz	-15.96	236.1	3.05
	Meas. 1.73 GHz	-25.50	196.9	0.85

The differences between simulation and measurement result are caused by the losses influenced by the distance, cables and connectors.

B. Radiation Pattern

The radiation characteristics are also investigated and shown in Fig. 5.

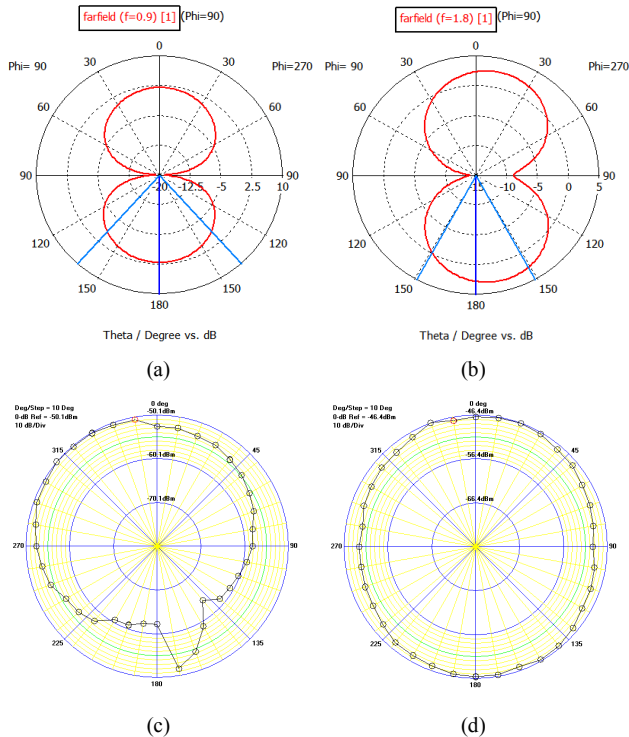

Fig. 5: Antenna's radiation pattern for (a) simulation at 900 MHz (b) simulation at 1800MHz (c) measurement at 900 MHz (d) measurement at 1800 MHz

The simulated radiation pattern indicates that the antenna radiates directionally while the measured radiation pattern is omnidirectional. The different patterns of simulation and measurement are observable and this might be caused by the environment around the antenna such as metallic influence which affected the measurement process.

C. Impedance Matching

The simulated impedance results are shown in Fig. 6. The planar dual-band monopole antenna shows impedance of $77.78-j9.01 \Omega$ at 915 MHz and $38.27+j7.20 \Omega$ at 1800MHz.

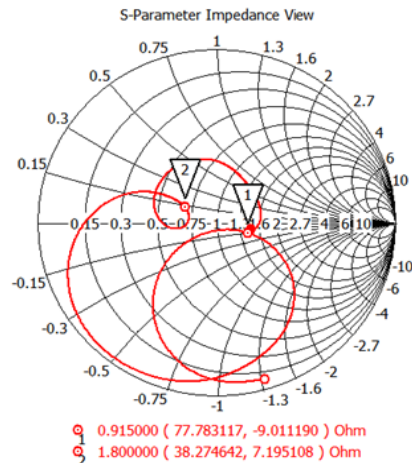

Fig. 6: Simulated impedance matching

It is observed that the antenna is not well matched to the 50Ω impedance. However, a design of matching circuit can be proposed to match the impedance of the antenna with the rectifying circuit. This is to ensure the optimum power transfer can be delivered.

D. Surface Current

Fig. 7 shows the surface current of the dual-band monopole antenna.

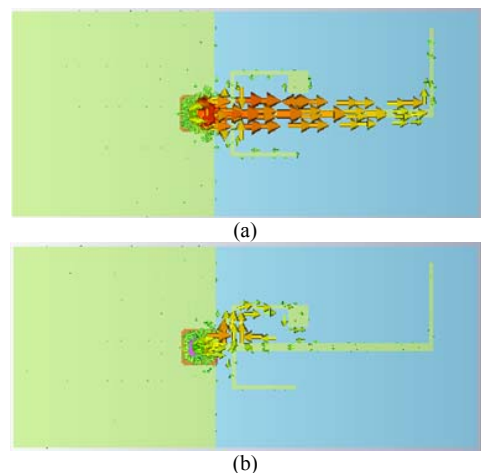

Fig. 7: Simulated radiation patterns of dual-band monopole antenna at (a) 900 MHz (b) 1800 MHz

From the figures, the current for lower frequency is radiated at A1 arm while A2 and A3 arm radiate the current for upper frequency.

E. Output Voltage and Output Power

An experimental test has been conducted by varying the distance, D between the transmitting and receiving antenna. The input power of transmitting antenna is injected directly from a signal generator ranged from -20dBm to 20dBm. The output voltage and output power at the receiving antenna is then measured by using a spectrum analyzer.

Table II, Table III and Table IV show the output result from the receiving antenna based on different distances, D equal to 75, 50, and 25 cm. From these tables, it can be observed that the variation of distance and input power will affect the receiving antenna's output. The output voltage and power increased when the distance, D of the transmitting and receiving antenna is reduced. The output voltage and power are also increased when the input power increased.

Hence, it can be concluded that the output voltage and output power is inversely proportional to the distance between transmitting and receiving antenna. However, the output voltage and output power is directly proportional to the input power.

TABLE II. MEASURED ANTENNA OUTPUT VOLTAGE AND OUTPUT POWER AT D = 75CM

Transmit Antenna	Receive Antenna		
	Output Voltage	Output Power (W)	Output Power (dBm)
Input Power			
-20 dBm	25.47 mV	15.36 μ W	-18.14 dBm
-10 dBm	31.95 mV	20.41 μ W	-15.66 dBm
0 dBm	36.85 mV	27.16 μ W	-16.90 dBm
10 dBm	74.73 mV	122.46 μ W	-9.12 dBm
20 dBm	192.97 mV	753.35 μ W	-1.23 dBm

TABLE III. MEASURED ANTENNA OUTPUT VOLTAGE AND OUTPUT POWER AT D = 50CM

Transmit Antenna	Receive Antenna		
	Output Voltage	Output Power (W)	Output Power (dBm)
Input Power			
-20 dBm	30.79 mV	17.33 μ W	-17.43 dBm
-10 dBm	31.22 mV	19.49 μ W	-16.87 dBm
0 dBm	35.11 mV	24.66 μ W	-16.08 dBm
10 dBm	74.73 mV	120.78 μ W	-9.42 dBm
20 dBm	234.69 mV	1.1 mW	0.42 dBm

TABLE IV. MEASURED ANTENNA OUTPUT VOLTAGE AND OUTPUT POWER AT D = 25CM

Transmit Antenna	Receive Antenna		
	Output Voltage	Output Power (W)	Output Power (dBm)
Input Power			
-20 dBm	30.16 mV	19.72 μ W	-17.05 dBm
-10 dBm	32.21 mV	23.38 μ W	-16.31 dBm
0 dBm	53.82 mV	57.94 μ W	-12.37 dBm
10 dBm	118.44 mV	280.54 μ W	-5.52 dBm
20 dBm	331.51 mV	2.19 mW	3.42 dBm

This experimental work is an early effort done for the antenna of an energy harvester. The performance may be improved by designing antennas with optimum performance to capture as much energy as possible and able to capture more energy even further. It is recommended to discover and design the most suitable antenna topology in order to produce better output.

IV. CONCLUSION

In this paper, the performance of a planar dual-band monopole antenna has been presented. The antenna operates at 915MHz and 1800MHz for GSM band application. The antenna's measured return loss is better than the simulation value. However, the resonance frequencies are slightly shifted. Nevertheless, it is able to cover the frequency range of interest. The gain at 1800MHz is higher than the gain at 915MHz frequency. Hence, the antenna radiates well at 1800MHz frequency with an omnidirectional pattern compared to the radiation pattern at 915MHz. The measured antenna bandwidth at 915MHz represents 13.6% for $\|S_{11}\| \leq 10$ dB, while the antenna bandwidth at 1800MHz represents 10.9% for $\|S_{11}\| \leq 10$ dB. Future works can be done to improve the bandwidth of the antenna by increasing the substrate thickness or by adding parasitic elements. Additional microstrip lines at the antenna may be used to enhance it to a multiband antenna.

ACKNOWLEDGMENT

The authors would like to thank UTeM for sponsoring this work under the CoE, research grant UTeM, PJP/2012/CeTRI/Y00001.

REFERENCES

- [1] Z. Zakaria, N. A. Zainuddin, M. N. Husain, M. Z. A. Abd Aziz, M. A. Mutalib, A. R. Othman "Current Developments of RF Energy Harvesting System for Wireless Sensor Networks ", *AISS: Advances in Information Sciences and Service Sciences*, Vol. 5, No. 11, pp. 328 - 338, 2013.

- [2] M. Z. A. Abd Aziz, Z. Zakaria, M. N. Husain, N. A. Zainuddin, M. A. Othman, B. H. Ahmad, "Investigation of Dual and Triple Meander Slot to Microstrip Patch Antenna," *Microwave Techniques (COMITE)*, pp. 36-39, 17-18 April 2013.
- [3] Burch J. B. et al., "Radio Frequency Nonionizing Radiation in a Community Exposed to Radio and Television Broadcasting", *Environmental Health Perspectives*, vol. 114, no. 2, February 2006.
- [4] Penella M. T. et al., "Powering Wireless Sensor Nodes: Primary Batteries Versus Energy Harvesting", *IEEE Instrumentation and Measurement Technology Conference*, May 2009.
- [5] Agrawal N. P., Kumar G., and Ray K. P., "Wideband Planar Monopole Antennas", *IEEE Trans. Antennas Propagation.*, vol. 46, pp. 294-295, February 1998.
- [6] Ammann M. J., "Wideband Antenna for Mobile Wireless Terminal", *Microwave and Optical Technical Letters*, vol. 26, no. 6, September 2000.
- [7] Evans J. A., Ammann M. J., "Planar Trapezoidal and Pentagonal Monopoles with Impedance Bandwidths in Excess of 10:1", *IEEE Antennas and Propagation Society International Symposium*, vol. 3, pp. 1558-1561, July 1999.
- [8] Chen Z. N., "Impedance Characteristics of Planar Bow-Tie-Like Monopole Antennas", *Electronic Letters*, vol. 36, no. 13, pp. 1100-1101, June 2000.
- [9] Z. Zakaria, W.Y. Sam, M. Z. A. Abd Aziz and M. A. Meor Said, "Rectangular Microstrip Patch Antenna Based on Resonant Circuit Approach" *IEEE Symposium on Wireless Technology and Applications (ISWTA)*, pp.233-236, 2012.
- [10] Z. Zakaria, W. Y. Sam, M. Z. A. Abd Aziz, A. Awang Md Isa, and F. Mohd Johar, "Design of Integrated Rectangular SIW Filter and Microstrip Patch Antenna", *IEEE Asia-Pacific Conference on Applied Electromagnetics (APACE)*, pp. 137-141, 2012.
- [11] M. S. Mohamad Isa, R. J. Langley, S. Khamas, A. Awang Md Isa, M. S. I. M. Zin, F. M. Johar, and Z. Zakaria, "Antenna Beam Steering using Sectorized Square EBG," *Journal of Telecommunication, Electronic and Computer Engineering (JTEC)*, vol. 4 No 1, pp. 39-44, 2012.
- [12] Suh S. Y., Stutzman W. L., Davis W. A., "A New Ultrawideband Printed Monopole Antenna: The Planar Inverted Cone Antenna (PICA)", *IEEE Trans. Antennas Propagation*, vol. 52, no. 5, pp. 1361-1364, May 2004.
- [13] Kerkhoff A. J., Rogers R. R., Ling H., "Design and Analysis of Planar Monopole Antennas Using a Genetic Algorithm Approach," *IEEE Trans. Antennas Propagations*, vol. 2, pp. 1768-1771, June 2004.
- [14] Ammann M. J., "Impedance Bandwidth of the Square Planar Monopole", *Microwave and Optical Technical Letters*, vol. 24, no. 3, February 2000.
- [15] Antonio-Daviu E., Cabedo-Fabres M., Ferrando-Bataller M., Valero-Nogueira A., "Wideband Double-Fed Planar Monopole Antennas", *Electronic Letters*, vol. 39, no. 23, pp. 1635-1636, November 2003.