

A Low-Loss Coaxial Cavity Microwave Bandpass Filter with Post-Manufacturing Tuning Capabilities

Z. Zakaria¹, M. S. Jawad, N. Omar, A. R. Othman, V. R. Gannapathy

Centre for Telecommunication Research and Innovation (CeTRI), Faculty of Electronic and Computer Engineering, Universiti Teknikal Malaysia Melaka (UTeM), Hang Tuah Jaya 76100 Durian Tunggal Melaka Malaysia.

¹Email: zahriladha@utem.edu.my

Abstract—This paper presents a low-loss coaxial cavity microwave bandpass filter with post-manufacturing tuning capabilities. A systematic filter development using a low-pass prototype as the starting point to produce a fourth-degree Chebyshev bandpass response is demonstrated. The coaxial cavity filter based on the transverse electromagnetic mode of the propagation has a center frequency of 2.5 GHz and a bandwidth of 160 MHz. An insertion loss (S₂₁) of 0.15 dB and a return loss (S₁₁) better than 15 dB are obtained, particularly in the passband. An excellent agreement between ideal circuit, EM simulation and measurement results has been achieved. The filter is then modified to have two channels, known as a diplexer, wherein center frequencies are at 2.5 GHz and 2.9 GHz at a bandwidth of 200 MHz. This type of microwave filter will be useful in any microwave system wherein low insertion loss and high selectivity are crucial, such as in base station, radar, and satellite transceivers.

Keywords - Microwave filter, Coaxial filter, Comblin filter, Diplexer

I. INTRODUCTION

Microwave systems have a significant impact on modern society. Their applications are diverse which for example, providing entertainment via satellite television and have been used in civil and military radar systems. In the field of communication, cellular radio is becoming as widespread as conventional telephony. In all these systems, microwave and radio-frequency filters are widely used to discriminate between wanted and unwanted signal frequencies. Cellular radio provides particularly stringent filter requirements both in base stations and mobile handsets.

Comblin cavity filters are the most common microwave filters used in modern systems, such as cellular phone base stations and satellites. The comblin filter is first introduced by Matthaei in 1964 and is the most widely used type of coaxial resonators, at least for frequency below 10 GHz [1]. It comprises an array of parallel coaxial resonators which are short-circuited at one end and with a loading capacitor at the other end. They are compact, easy to design, and possess excellent stopband and high selectivity features. More importantly, they have an advantage with post-manufacturing tuning capabilities. Comblin cavity filters also provide outstanding performance from the UHF region at up to 10 GHz with a relatively higher Q factor (ranging from 2,000 to 5,000) than microstrip technology [2 - 5]. They also have many attractive features, including an electromagnetic shielding structure, low-loss characteristics, and a smaller size.

Due to current demands of wireless communication system, two microwave filters can be combined to create a diplexer wherein two different frequencies can be used together and implemented. The principle operation of a diplexer is to allow one filter working with dual frequencies. In transceiver applications they are commonly used behind wideband or multi frequency antennas [6 - 10].

Normally, a diplexer has three ports, one of which is for input signals, whereas the other two are output ports. Thus, two different microwave filters will be designed in the multi-port circuit. A diplexer is best used in multi-band communication systems because it can isolate a signal according to the design created. The idea is to combine two bandpass filters, thus this device has three ports, as mentioned earlier, one input port and two output ports [12 - 14].

Filter tuning in coaxial resonator filters can be realized through tuning screws. In this case, the tuning screws are adjusted or inserted [15] into the cavity from the lid towards resonator stubs. The method of filter tuning was first investigated by Dishal [16], and was implemented on coupled-resonator filter by observing the reflection coefficient at the resonant frequency. The technique has been further experimentally updated by Ness [15], as a result of measuring the group delay of the reflection coefficient until the desired number of ripples in return loss is obtained.

This paper focuses on the design of coaxial cavity filter and then has been modified into a diplexer. The first section of this paper will demonstrate the development of a comblin cavity filter using low-pass prototype.

Design of a single combline filter at frequency 2.5 GHz and a diplexer at frequency 2.4 GHz and 2.9 GHz will be demonstrated in second and third section. Finally, the measurement results will be discussed and the conclusion will be drawn in the last section.

II. DESIGN OF CAVITY FILTER

In this section, the development of a systematic combline cavity filter using a low-pass prototype as the starting point will be demonstrated. A Chebyshev response will be used in the example because this response is widely employed and has a relatively high selectivity compared to Butterworth response. Three dimensions electromagnetic Ansoft HFSS software used to model and simulate real physical filter as three dimensions. The High Frequency Structural Simulator (HFSS) is important for designing high frequency part that uses in modern electronic applications. By using HFSS, most of 3D EM problems can be solved quickly as it combines simulation, visualization, solid modeling and automation in easy to learn environment.

For realization, the low-pass prototype is transformed into a combline bandpass filter. The theory behind the transformation is explained in detail in [17 - 23].

Low-pass prototype networks are two-port lumped-element networks with an angular cutoff frequency of 1 rad/s and operating in a 1Ω system.

The formula to calculate the degree of Chebyshev filter is given [17] :

$$N \geq \frac{L_A + L_R + 6}{20 \text{Log}_{10}[S + \sqrt{S^2 - 1}]}, \quad (1)$$

Where L_A is the stopband insertion loss, L_R is the passband return loss, and S is the ratio of stopband to passband frequencies.

Element values can now be calculated by determining the level of insertion loss:

$$\epsilon = (10^{L_R/10} - 1)^{-1/2}. \quad (2)$$

The equations of prototype elements introduce a new parameter η :

$$\eta = \sinh \left[\frac{1}{N} \sinh^{-1} \left(\frac{1}{\epsilon} \right) \right]. \quad (3)$$

Element values for the Chebyshev low-pass prototype are calculated using the following formulas:

$$K_{r,r+1} = \frac{[\eta^2 + \sin^2(\frac{r\pi}{N})]^{1/2}}{\eta} \quad (4)$$

and

$$C_{Lr} = \frac{2}{\eta} \sin \left[\frac{(2r-1)\pi}{2N} \right], \quad (5)$$

Where $K_{r,r+1}$ is the r_{th} of the admittance inverter and C_{Lr} is the r_{th} of the capacitor.

The low-pass prototype network can now be transformed into a combline bandpass filter by applying the following equation [17] :

$$Y_r = \alpha C_{Lr} \tan(\theta). \quad (6)$$

Equation (6) represents admittance of a short-circuited stub of characteristic admittance, where C_{Lr} is the r_{th} capacitor in the prototype network, θ represents the electrical length of resonators at the center frequency ω_0 of the filter, and α is the bandwidth scaling factor.

The equivalent circuit of the combline filter is obtained by simply adding shunt capacitor C_r from the r_{th} node to the ground. The formula for calculating capacitor C_r of the combline filter equivalent circuit is given by:

$$C_r = \beta Y_r, \quad (7)$$

Where β is represented by:

$$\beta = \frac{1}{\omega_0 \tan \theta}, \quad (8)$$

Where $\omega = 0$ in the low-pass prototype maps to ω_0 in the combline bandpass filter. Impedances of all circuit elements in the filter are then scaled to a 50 Ω system.

Figure 1 (a) shows the combline bandpass filter circuit and its elements which are operating in a 50 Ω system. Element values of the equivalent combline bandpass filter in a 50 Ω system are shown in Table 1. The simulated response of the combline bandpass filter is shown in Figure 1 (b). The combline bandpass filter has the following design specification: center frequency of 2.5 GHz with a 160 MHz bandwidth. An insertion loss of 0.04 dB and a return loss better than 20 dB are obtained, particularly in the passband.

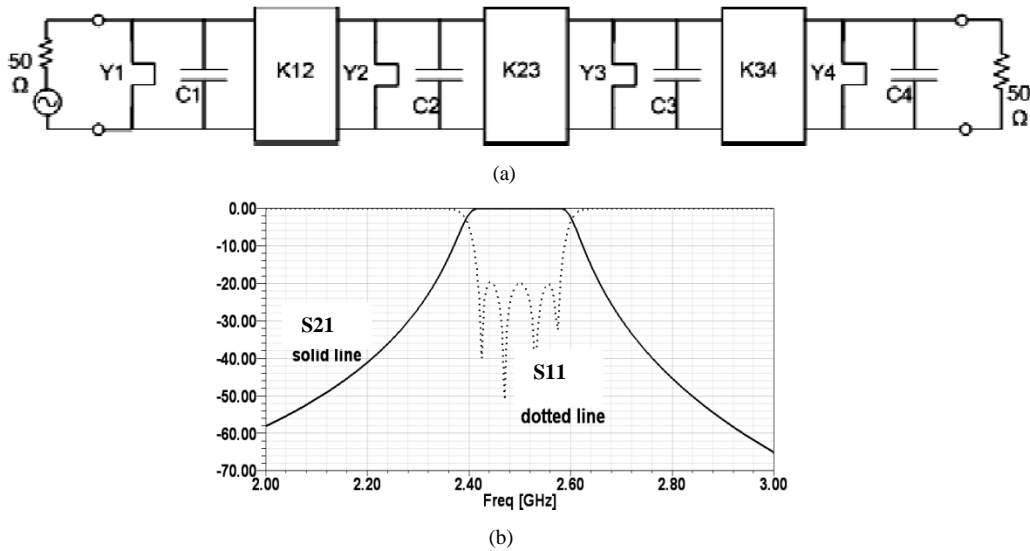

Figure 1. (a) Combline filter operating in a 50 Ω system. (b) Frequency response of a bandpass filter.

TABLE I. ELEMENT VALUES OF COMBLINE BANDPASS FILTER.

Elements of combline bandpass filter	Values
$C_1 = C_4$	15.994 pF
$C_2 = C_3$	38.62 pF
$Y_1 = Y_4$	9.1287 mho
$Y_2 = Y_3$	22.044
$K_{12} = K_{34}$	0.0264
K_{23}	0.03154

The equivalent circuit of the combline bandpass filter can now be transformed into the physical layout indicated in Figure 2. Figure 3 shows the dimension of the physical filter.

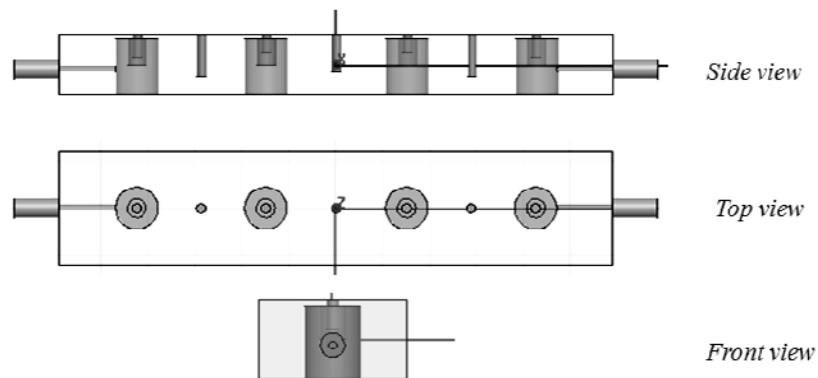

Figure 2. Physical filter layout.

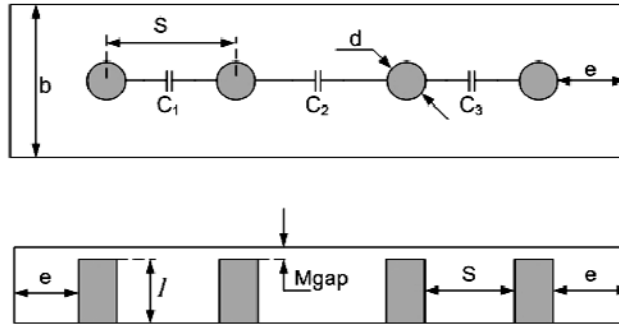

Figure 3. Dimensions of the physical filter: (a) top view and (b) side view.

Dimensions of the physical filter can be determined as follows.

Cavity diameter, b , in mm:

$$\lambda < b < 0.2 \lambda, \tag{9}$$

where λ is the wavelength at 2.5 GHz.

Resonator diameter, d , in mm:

$$0.2b < d < 0.4b. \tag{10}$$

Rod diameter is a function of impedance and cavity diameter. Hunter [9] provides the characteristic impedance, Z_0 , of around rod between two ground planes as:

$$Z_0 = 138 \times \log \left[\frac{4b}{\pi d} \right]. \tag{11}$$

The distance between the end wall and the first or last resonator, e , can be found using:

$$e = \left(\frac{b}{2} \right) + \left(\frac{d}{2} \right). \tag{12}$$

The gap between the lid and the resonator should be sufficient to provide necessary capacitance, and can be calculated using:

$$M_{gap} = \frac{0.695d^2}{100C - 2.61d}, \tag{13}$$

Where C is the loading capacitance and d is the rod diameter.

The distance between resonators, $S_{com(i,j)}$, can be calculated using:

$$S_{comb(i,j)} = \frac{b}{1.37} \left[\left(0.91 \frac{b}{d} \right) + 0.048 - \log \left(\frac{4}{\pi} \cdot f(\theta) \cdot K_{ij} \right) \right], \tag{14}$$

where

$$f(\theta) = \frac{1}{2} \left[1 + \frac{2\theta}{\sin 2\theta} \right] \tag{15}$$

and

$$\theta = 2\pi \frac{l}{\lambda}. \tag{16}$$

Physical layout parameters are listed in Table II. The physical layout filter was modeled and simulated using three-dimensional (3-D) Ansoft HFSS software, as shown in Figure 4. The electromagnetic (EM) simulated response is shown in Figure 5. An insertion loss of about 0.1 dB and a return loss better than 13 dB has been achieved, particularly in the passband. Figure 6 shows the field distribution of the coaxial resonators.

TABLE II. DIMENSIONS OF A REAL LAYOUT FILTER.

Physical layout parameters	Values (mm)
Cavity diameter (b)	24
Resonator diameter (d)	8
Resonator length (l)	12
Tap point distance from the ground	3.5
Minimum gap ($Mgap$)	0.5
Center to center spacing between resonators (S_i, j)	19.5, 21.5, 19.5
Distance between end wall to center of end rod (e)	14

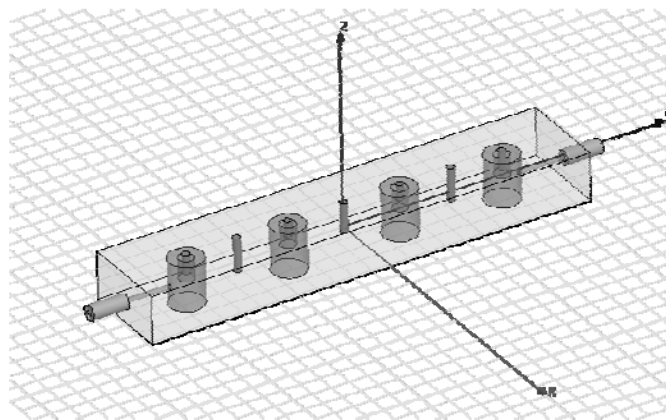

Figure 4. The 3-D HFSS model of the physical filter.

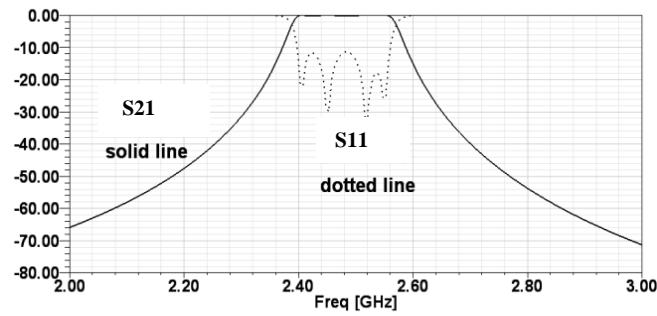

Figure 5. The 3-D EM response.

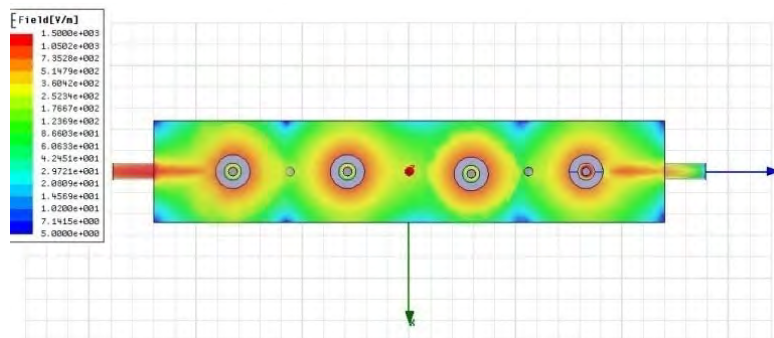

Figure 6. Field distribution of resonators.

The filter requires further tuning and optimization to obtain an effective response. However, the structure of this non-planar filter requires a powerful and high-performance computer to carry out the optimization.

III. DESIGN OF THE DIPLEXER AT 2.5 GHz AND 2.9 GHz

The initial design of the diplexer is similar to that of the single channel of a cavity filter. Design 2 of the single cavity filter should be combined, and the combination should have a slightly different circuit design. Figure 7 (a) shows the elements of the diplexer circuit. Figure 7 (b) shows the circuit level of the diplexer in Advanced Design System ADS. The response of the ideal circuit is shown in Figure 8. An insertion loss of about 0.04 dB and a return loss better than 20 dB has been achieved, particularly in the passband.

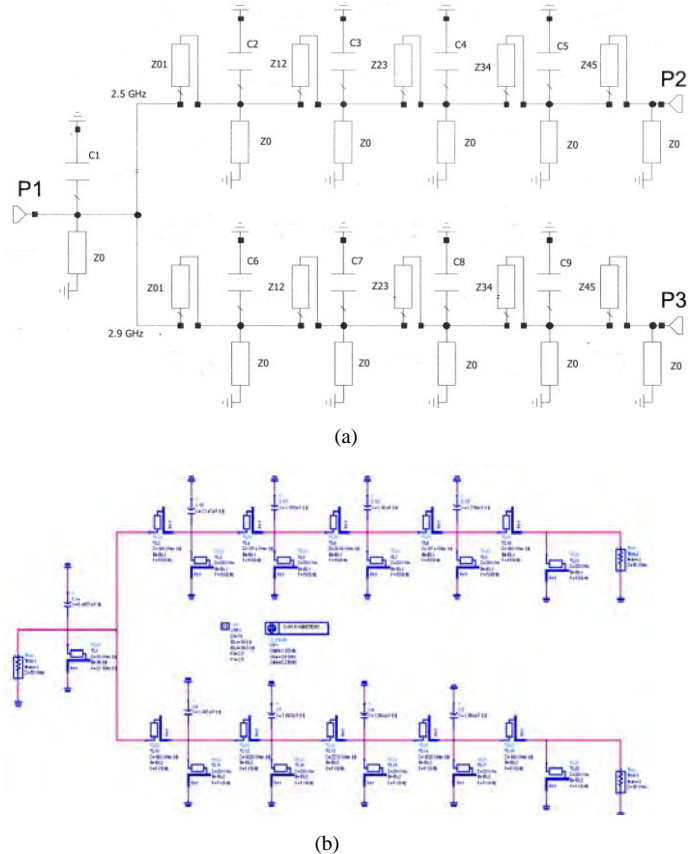

Figure 7. (a) Element used in the diplexer circuit, (b) Circuit level for the diplexer in ADS.

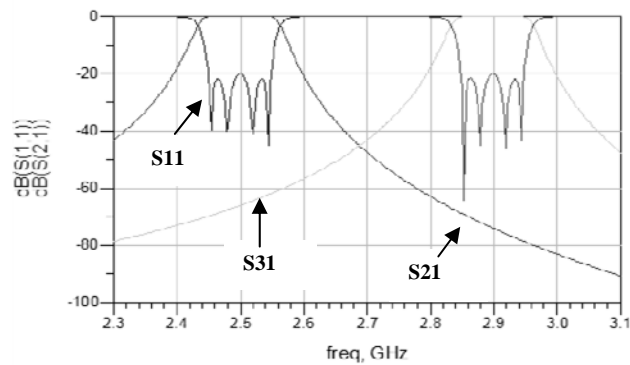

Figure 8. Simulation result of diplexer circuit design

For the diplexer design, the value of impedance, Z_0 must be scaled to 70Ω to provide a optimum Q-factor. Table III shows the values of each element for the circuit level.

TABLE III. ELEMENT VALUES FOR THE DIPLEXER CIRCUIT.

Parameters	2.5GHz	2.9GHz
Z0 (Ω)	70	70
Z1 (Ω)	70	70
Z2 (Ω)	70	70
Z3 (Ω)	70	70
Z4 (Ω)	70	70
Z5 (Ω)	70	70
Z01 (Ω)	160	160
Z12 (Ω)	1374	1520
Z23 (Ω)	2018	2270
Z34 (Ω)	1374	1520
Z45 (Ω)	160	160
C1(pF)	1.747	1.387
C2(pF)	1.359	1.063
C3(pF)	1.360	1.064
C4(pF)	1.758	1.384

By using the same equation from the single channel (9-13), all values were used to calculate the physical dimensions of the diplexer. Table IV shows physical dimension values of the diplexer.

TABLE IV. PHYSICAL DIMENSIONS OF THE DIPLEXER.

Frequency (GHz)	2.5	2.9
Cavity length, b (mm)	20	18
Cavity height, h(mm)	12.5	11.5
Resonator diameter, d (mm)	8.0	7.0
Resonator length, l (mm)	12.0	11.0
Minimum gap, Mgap (mm)	0.5	0.5
Center to center spacing between resonators ($S_{i,j}$)	12.5, 22.0, 25.0	11.0, 21.0, 23.0

The physical layout filter is modeled and simulated using HFSS simulation tools. Figure 9 shows the 3D design of diplexer using HFSS to produce dual band frequencies.

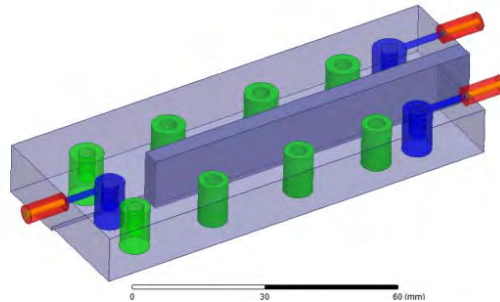

Figure 9. Model of the diplexer using HFSS tools.

IV. FABRICATION AND MEASUREMENT

The manufacturing process of combline filter is shown in figure 10. The filter is manufactured in-house using a computer numerically controlled (CNC) machine and aluminium as the material.



Figure 10. Manufacturing of the filter.

The filter is measured and verified using a vector network analyzer, as shown in Figure 11. A photograph of the filter is shown in Figure 12. Screws are inserted between resonators to overcome manufacturing tolerances. Inter-resonators couplings then tuned using the inserted screws, and an optimized return loss value better than -15 dB has been achieved over the required bandwidth. The measured response is shown in Figure 13. An insertion loss of about 0.15 dB and a return loss better than 15 dB have been achieved. Table V shows the comparison between ideal EM simulations and measurement results. An excellent agreement between ideal EM simulations and measurement results has been achieved.



Figure 11. Measurements and Verification of the filter: (a) with lid and (b) without lid.



(a)



(b)

Figure 12. Photograph of the physical filter: (a) with lid and (b) without lid.

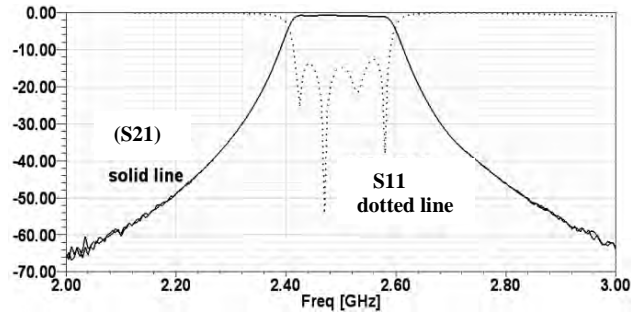
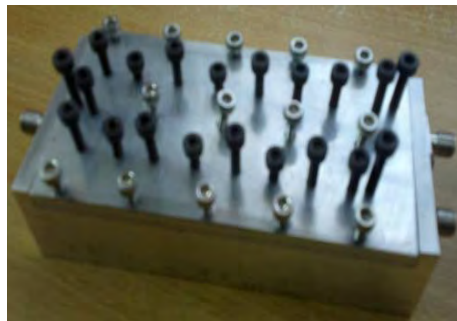

Figure 13. Measured response of the physical filter.

TABLE V. COMPARISON BETWEEN SIMULATIONS AND MEASUREMENT RESULTS.

	Ideal circuit	3-DEM	Measurement result
Center Frequency (GHz)	2.5	2.48	2.5
Passband BW (MHz)	160	170	168
Stopband BW (MHz)	320	300	290
S11 [dB]	-20	-13	-15
S21 [dB]	-0.04	-0.10	-0.15

The diplexer is also going through the same fabrication operation using the CNC machine. Figure 14 presents the diplexer layout after the fabrication process, whereas figure 15 shows the measurement using the network analyzer. The measurement steps for the diplexer are similar with single channel of a cavity filter. Figure 16 indicates the response after the filter has been tuned with tuning screws. After the fabrication process, the measurement which shows a good insertion and return loss has been achieved. Table VI shows the comparison between the ideal circuit view of the diplexer and measurement values.



(a)



(b)

Figure 14. The diplexer after the fabrication process: (a) with tuning screws and (b) internal view of the diplexer.



Figure 15. Measurement of the diplexer.

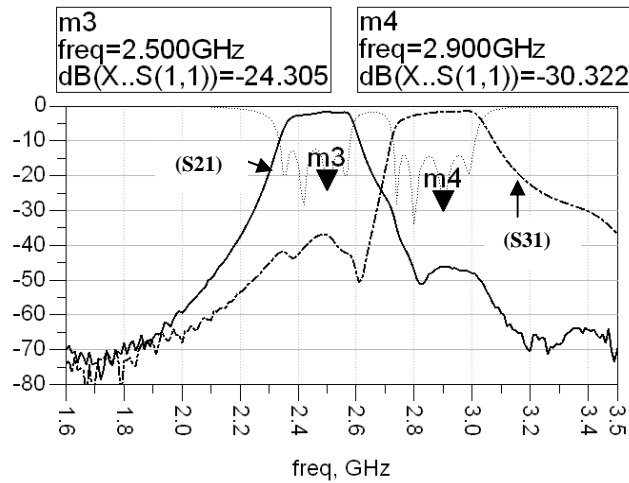

Figure 16. Response of the diplexer after the measurement.

TABLE VI. COMPARISON BETWEEN SIMULATIONS AND MEASUREMENT RESULTS.

	Ideal Circuit		Measurement Results	
	2.5	2.9	2.46	2.85
Center frequency	2.5	2.9	2.46	2.85
Passband BW (MHz)	100	100	200	200
Stopband BW (MHz)	320	320	420	420
S11 [dB]	-20	-20	-14.33	-14.42
S21 [dB]	-0.04	-0.04	-1.4	-1.4

V. CONCLUSION

A coaxial cavity combine bandpass filter has been successfully designed, fabricated, and measured. Filter development using the Chebyshev low-pass prototype as a starting point has been demonstrated followed by a systematic physical realization. The resulting filter exhibits excellent agreement between ideal simulated and measured responses. Similarly for the diplexer, the measured results are in line with the simulated response. The main advantages of the coaxial resonator filter are its post-manufacturing tuning capabilities and good selectivity. This class of microwave filter will be useful in any transceiver system where low-loss and high-performances are required.

ACKNOWLEDGEMENT

The authors would like to thank UTeM for sponsoring this research under the research grant UTeM, FRGS(RACE)/2012/FKEKK/TK02/02/1 F00147 and RAGS/2012/UTEM/TK02/2.

REFERENCES

- [1] G. Matthaei, L. Young, and E.M.T. Jones, Microwave Filters, Impedance Matching Networks and Coupling Structures. *Dedham, MA: Artech House*, 1964.
- [2] I. C. Hunter, R. Ranson, A. C. Guyette, and A. Abunjaileh, "Microwave filter design from a systems perspective", *IEEE Microwave Magazine*, October 2007.
- [3] Z. Zakaria, M. Ariffin Mutalib, K. Jusoff, M. S. Mohamad Isa, M. A. Othman, B. H. Ahmad, *et al.* "Current developments of microwave filters for wideband applications," *World Applied Sciences Journal (WASJ)*, vol. 21, pp. 31-40, 2013.
- [4] Z. Zakaria, I.C. Hunter, A.C. Guyette, "Design of Coaxial Resonator with Nonuniform Dissipation", 2008 IEEE MTT-S International Microwave Symposium Digest, pp. 623 – 626, Atlanta, US, 2008.
- [5] Z. Zakaria, A. Sabah, W. Y. Sam, "Design of low-loss coaxial cavity bandpass filter with post-manufacturing tuning capabilities," *2012 IEEE Symposium on Business, Engineering and Industrial Applications (ISBEIA)*, pp. 733-736, 2012.
- [6] M.S. Mohamad Isa, R. Langley, S.Khamas, A. Awang Md Isa, M.S.I.M. Zin, F.M. Johar, Z.Zakaria " Microstrip Patch Antenna Array Mutual Coupling Reduction using Capacitive Loaded Miniaturized EBG", *Journal of Telecommunication, Electronic and Computer Engineering (JTEC)*, Vol.4 No.2 July-December 2012
- [7] M.Z.A. Abd Aziz, Z. Zakaria, M.N. Husain, N.A. Zainuddin, M.A. Othman, B.H. Ahmad, "Investigation of Dual and Triple Meander Slot to Microstrip Patch Antenna", 2013 International Conference on Microwave Techniques (COMITE), pp. 36-39, 2012.
- [8] A. R. Othman, K. Pongot, Z. Zakaria, M. K. Suaidi, A. H. Hamidon, "Low Noise Figure and High Gain Single Stage Cascoded LNA Amplifier With Optimized Inductive Drain Feedback for WiMAX Application", *International Journal of Engineering and Technology (IJET)*, Vol 5 No 3 Jun-Jul 2013.
- [9] M.S. Mohamad Isa, R.J. Langley, S. Khamas, A. Awang Md Isa, M.S.I.M. Zin, F.M. Johar, Z. Zakaria, "Antenna Beam Steering Using Sectorized Square EBG", *Journal of Telecommunication, Electronic and Computer Engineering (JTEC)*, vol. 3 no 1, pp. 39-44, Jan - Jun 2012.
- [10] N. A. Shairi, B. H. Ahmad, P. W. Wong, Z. Zakaria, "Single Switchable Open Stub Resonator in SPDT Switch Design", 2012 IEEE Symposium on Wireless Technology & Applications (ISWTA 2012), Bandung, Indonesia, Sept. 23 – 26, 2012.
- [11] B. Strassner, K.Chang, "Wide-band low-loss high-isolation microstrip periodic-stub diplexer for multiple-frequency applications," *Microwave Theory and Techniques, IEEE Transactions on* , vol. 49, no. 10, pp. 1818-1820,2001
- [12] W. Xi, Y.W. Qing, H.Z. Yuan and L. Hong, "Design of a Compact Diplexer", IEEE MTT-S International Microwave Workshop Series on Art of Miniaturizing RF and Microwave Passive Components, 2008.
- [13] M. Sánchez-Renedo, R. Gómez-García., "Microwave dual-band bandpass planar filter using double-coupled resonating feeding sections," *Microwave Conference, 2009. EuMC 2009. European* ,pp. 101-104, 2009.
- [14] W. Xia, X. Shang, M.J. Lancaster, "Responses Comparisons for Coupled-Resonator Based Diplexers", IEEE Passive RF and Microwave Components, 3rd Annual Seminar, 2012.
- [15] J.B. Ness, "A unified approach to the design, measurement, and tuning of coupled-resonator filters," *IEEE Transactions on Microwave Theory and Techniques*, vol. 46, no. 4, pp. 343-351,1998
- [16] M.Dishal,"Alignment and Adjustment of Synchronously Tuned Multiple-Resonant-Circuit Filters," *Proceedings of the IRE* , vol. 39, no. 11, pp. 1448-1455, 1951
- [17] I.C. Hunter, Theory and Design of Microwave Filters. *Stevenage, U.K.: IEEE*, 2001.
- [18] Z. Zakaria, W. Y. Sam , M.Z.A.A. Aziz, A. A.M.Isa, F.M. Johar, "Design of integrated rectangular SIW filter and microstrip patch antenna," *2012 IEEE Asia-Pacific Conference on Applied Electromagnetics (APACE)*, pp. 137-141, 2012.
- [19] Z. Zakaria, W. Y. Sam, M.Z. Abd Aziz, M. Muzafar Ismail, "The Integration of Rectangular SIW Filter and Microstrip Patch Antenna based on Cascaded Approach", *Procedia Engineering*, Volume 53, pp 347–353, 2013.
- [20] M. J. L. Jia-Shen G. Hong, *Microstrip Filters For RF/ Microwave Applications*. Canada: John Wiley & Sons, Inc., 2001.
- [21] Z. Zakaria, W. Y. Sam, M. Z. A. Abd Aziz, M. S. Jawad, M. S. Mohamad Isa, "Investigation of Integrated Rectangular SIW Filter and Rectangular Microstrip Patch Antenna Based on Circuit Theory Approach", *International Journal of Advanced Studies in Computer Science and Engineering (IJASCSE)*, Vol 1, Issue 4, pp 46-55, 2012.
- [22] Z. Zakaria and I. Hunter, "Design of SIW Filter Based on Even and Odd Mode Predistortion Technique", *Journal of Telecommunication, Electronic and Computer Engineering (JTEC)*, vol. 3 no 2, pp. 61-71 , Jul - Dec 2011.
- [23] D. M. Pozar, *Microwave Engineering*. Hoboken, NJ: John Wiley & Sons, Inc., 2005.