

Soot particle trajectories of a Di diesel engine at 18° ATDC crankshaft angle

This content has been downloaded from IOPscience. Please scroll down to see the full text.

2013 IOP Conf. Ser.: Mater. Sci. Eng. 50 012003

(<http://iopscience.iop.org/1757-899X/50/1/012003>)

View [the table of contents for this issue](#), or go to the [journal homepage](#) for more

Download details:

This content was downloaded by: hafizputeri

IP Address: 183.171.170.154

This content was downloaded on 29/01/2014 at 04:17

Please note that [terms and conditions apply](#).

Soot particle trajectories of a Di diesel engine at 18° ATDC crankshaft angle

M H M Hafidzal^{1,a}, W M F W Mahmood², M Z A Manaf¹, M S Zakaria¹, M N A Saadun¹ and M N A Nordin¹

¹Faculty of Mechanical Engineering, Universiti Teknikal Malaysia Melaka, Hang Tuah Jaya, 76100, Durian Tunggal, Melaka, Malaysia

²Department of Mechanical and Materials Engineering, Faculty of Engineering and Built Engineering, Universiti Kebangsaan Malaysia, Malaysia

E-mail: ^ahafidzal@utem.edu.my

Abstract. Among the major pollutants of diesel engine is soot. Soot is formed as an unwelcome product in combustion systems. Soot emission to the atmosphere leads to global air warming and health problems. Furthermore, deposition of soot particles on cylinder walls contaminates lubricant oil hence increases its viscosity. This reduces durability of lubricant oil, causing pumpability problems and increasing wear. Therefore, it is necessary to study soot formation and its movement in diesel engines. This study focuses on soot particle trajectories in diesel engines by considering the diameter of soot particles that were formed at 18° ATDC crankshaft angle. These soot particle movements are under the influence of drag force with different radial, axial and angular settings and simulated by using MATLAB routine. The mathematical algorithm which was used in the MATLAB routine is trilinear interpolation and 4th order of Runge Kutta. Simulation was carried out for a combustion system of 4 valves DI diesel engine from inlet valve closing (IVC) to exhaust valve opening (EVO). The results show that small diameter of soot particles were transferred near the cylinder wall while bigger soot particle mostly moved in inner radius of the combustion chamber.

1. Introduction

Diesel engine has its drawbacks especially from an environmental perspective. Combustion in a diesel engine will release particulate matters (PM), nitrogen oxides (NO_x), sulfur oxides (SO_x) and noise emissions [1-6]. Particulate matter contains solid soot particles which will contaminate the lubricant oil, thus viscosity of the lubricant oil increases. Subsequently the walls of the combustion chamber will not be adequately coated which will increase its wear [7]. Besides that, when the viscosity of the lubricant oil increases, the interval between oil changes will also decrease [8].

The wear mechanism due to the soot is still not fully understood, therefore fundamental study about this area is needed. Previous researchers investigated on soot distribution in a diesel engine by using the CFD software, Kiva-3v. Kiva-3v is reliable software to simulate the soot formation in a diesel engine combustion chamber [9]. Kiva-3v implements a two stage of Hiroyasu soot model in the simulation. The two stage soot models are for soot formation and soot oxidation [10]. Research made by [8] carried out a soot particle size prediction along its path using combination of Hiroyasu's soot formation [6] and Nagle and Strickland-Constable soot oxidation [12] rate expression. Meanwhile, [13] also developed a model for soot formation process in diesel engine but the result of the model was



different to the experimental result. Other mechanisms that occur in the cylinders that causes soot deposition are thermophoresis, inertial deposition, electrophoresis and gravitational sedimentation. Among those mechanisms, thermophoresis was shown to be the most dominant [14]. According to another study, it is essential to understand how force acts on the soot particles in order to determine the soot movements [15]. The forces that act on the soot particles are drag, electrostatic, gravitational, acoustic, diffusio-phoretic and thermophoretic [16].

The objective of this study is to analyze soot movement at 18° crank angle ATDC in a cylinder of a diesel engine under the influence of drag force with different radial, axial and angular settings to predict the possibility of soot particles to stick to the wall of the cylinders.

2. Kiva-3v

Kiva-3v was used in previous investigation to obtain data of in-cylinder soot formation. The data that were obtained from the Kiva-3v simulation were velocity vectors of the soot, fuel, temperature, pressure and others [8]. In order to get the soot particle trajectories, the data from Kiva-3v was implemented by MATLAB software.

3. Specifications of engine

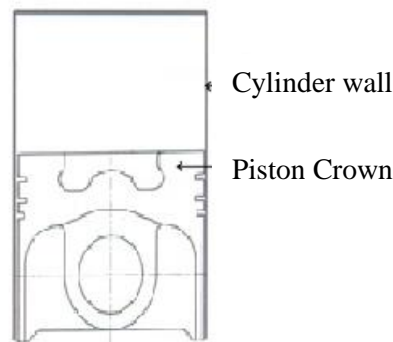

Figure 1. Crown piston configuration.

The engine has a bowl-in-piston and flat cylinder head face configuration, with a seven-hole injector installed vertically and centrally. The schematic diagram for crown piston configuration is shown in figure 1. The simulations were carried out for the combustion system of a 4 valve DI diesel engine from inlet valve closing (IVC) to exhaust valve opening (EVO). The specifications of the engine are bore \times stroke: 86.0 \times 86.0 mm, squish height: 1.3 mm, compression ratio: 18.2:1 and displacement: 500 cm³, speed: 2500rpm. The details of the specification of engine and mesh specification are shown in table 1 and table 2 [8].

Table 1. Specifications of the engine

Parameters	Specifications
Engine Type	4 valve DI diesel
Bore \times Stroke	86.0 \times 86.0 mm
Squish height	1.3 mm
Compression Ratio	18.2:1
Displacement	500 cm ³
Piston Geometry	Bowl-in-piston

Table 2. Specifications of the mesh configuration.

Parameters		Mesh configuration
Total number of cells		201,900
Number of cells	Azimuthal	150
	Radial	37 (20 in bowl region)
	Axial	39 (15 in bowl region)
Resolution	Azimuthal (°)	2.4°
	Radial (mm)	0.83 – 1.15
	Axial (mm)	0.99 – 3.63

**Figure 2.** Mesh configuration of piston bowl-in.

Figure 2 shows the top and side view of the mesh configuration of the piston. The data from experimental result by [4] was used for the simulation and was used for model validation.

4. Soot particle tracking

By using MATLAB, the data for soot concentration that was used by [8] was employed to investigate the soot movement in the combustion chamber. There are two methods to determine the formation of soot in a combustion chamber, which is individual tracking and cumulative tracking. This studies focusing on the individual tracking. The starting location of soot can be determined by assuming its velocity is the same as that particular flow velocity.

The soot movement starting from its formation which is after combustion process until the exhaust valve is open can be predicted by using numerical method. Euler method or also known as first stage of Runge-Kutta method is an easy way to calculate and determine the soot location. This method takes velocity at a certain location as soot velocity, and considered distance traveled by the soot. In order to get an accurate value, higher stage of the Runge - Kutta method can be used. And as for this study 4th Stage of Runge-Kutta is used to calculate the soot's location. On top of that, to investigate soot velocity at every condition trilinear interpolation method is used. In this study, the drag force equation is included in the simulation to determine soot movement. The drag force equation is

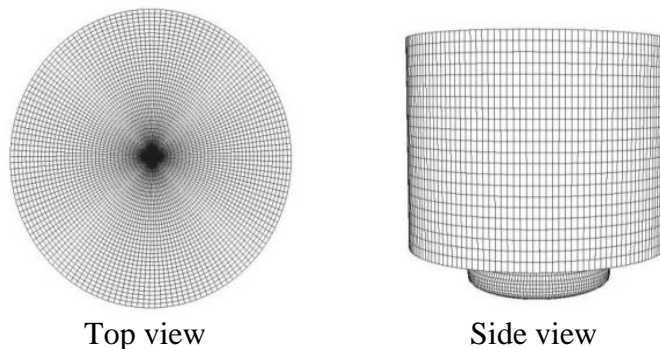
$$F_d = \frac{1}{2} \rho v^2 C_d A \quad (1)$$

F_d is the force of drag, ρ is the density of the fluid, v is the velocity of the object relative to the fluid, A is the area and C_d is the drag coefficient. To analyze the movement of the soot particles, it is necessary to identify the initial position of the soot particle. This can be found based on the zone of soot distribution with certain crank angle ATDC [8]. After selecting the crank angle and zone, the starting coordinate in radial (ρ), angular (θ) and axial direction (z) were also decided as below:

- a) Rho: 2.0-2.6 cm, $\theta=10^\circ$ and $z=10$ cm
 b) Rho= 2.3 cm, $\theta =15^\circ-30^\circ$, $z=10$ cm
 c) Rho= 2.3 cm, $\theta =10^\circ$, $z=9.5-10.2$ cm

Soot particle movement paths have been studied by considering reasonable crank angle .In present paper the reasonable crank angle that is investigated in is at 18° ATDC. 18° ATDC is the point where injection is already completed and soot formation process is dominating. A comparison of the soot particle influenced by different radial (rho), angular (theta) and axial direction (z) were carried out from the results of the simulation.

5. Results and discussions

By considering the radial sensitivity, rho: 2.0-2.6 cm, angular (θ): 10° and axial direction (z): 10 cm, the soot movement path from 18° ATDC to 120° ATDC was shown in figure 3. The results shows that when the piston moves downward, almost all the soot particles move downwards in anti-clock wise motion and moves towards middle of the cylinder wall. The combination of swirl, squish and reverse squish were the reason the soot particle moves towards the cylinder wall. It can be observed that, at rho=2cm the length path of soot movement is shorter compared to the other paths. In addition, it can be seen that an increase of radial, increases possibility of soot particle to move down towards middle of cylinder wall. The movement of soot near to the cylinder wall will cause contamination to the lubricant oil.

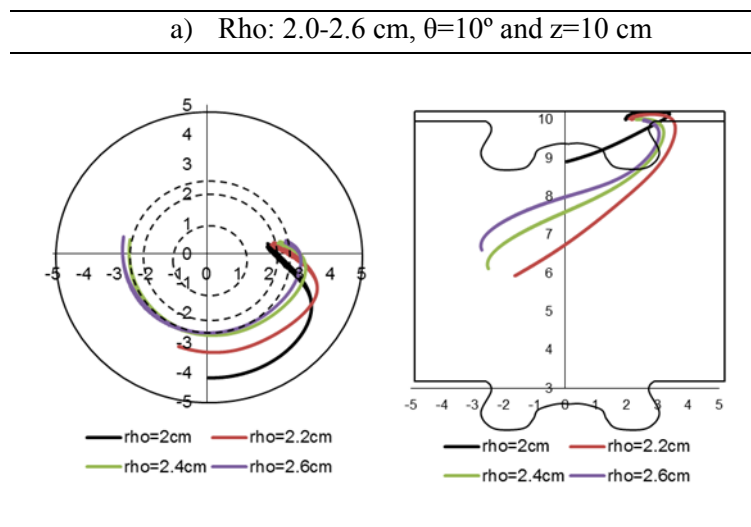

Figure 3. Radial sensitivity.

Analysis of the soot particle movement by considering the sensitivity of angular was also carried out. Figure 4 shows the Angular sensitivity: radial distance= 2.3 cm, $\theta =15^\circ-30^\circ$, $z=10$ cm. Almost of the soot particles move downwards in and anti-clockwise motion. It can be seen that, in this zone, the angular sensitivity has less influence on the soot particle movement as the comparison between movements of soot particle showed very similar result.

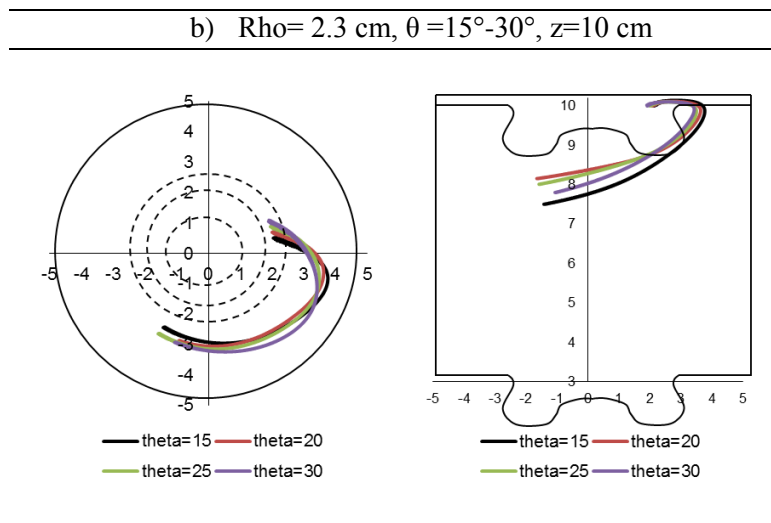
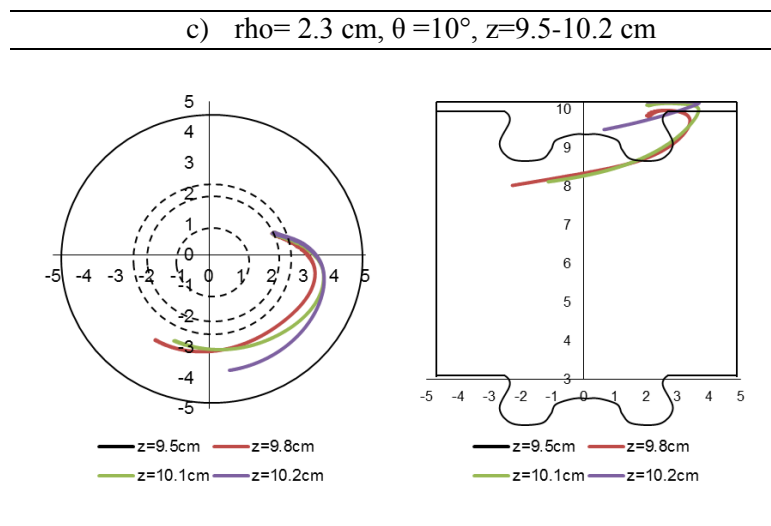

Figure 5 demonstrates the soot particle movement between axial distance= 2.3 cm, $\theta = 10^\circ$, $z = 9.5\text{-}10.2$ cm: of soot particle movement from 18° ATDC to 120° ATDC. At $z = 9.5$ cm, the soot particle paths are not available in the graph. It is because soot particles follow the velocity of air flow in the combustion chamber.

Besides that, it can be seen that, the soot particle movement paths become shorter as axial direction increases. On the other hand, as z decreases, soot particle has high tendency to go near to cylinder wall. Therefore, it is suggested to improve design of piston or fuel spray angle based on the results of the study.



6. Conclusions

In order to reduce lubricant oil contamination is to minimize the transfer of soot particles to the cylinder wall. By understanding the movement path of soot particle in diesel engine, measures to reduce soot particle movement towards the cylinder wall can be identified.

Soot particle movement in a diesel engine depends on the starting point in radial, angular and axial. Most of the soot particles at 18° ATDC at certain locations move downwards, anti-clockwise motion and not approaching the cylinder wall. Hence, the soot particles from these points are likely to

give a low risk to lubricant oil contamination problem. In addition the modification of the bowl, piston shape and spray angle is expected to reduce the possibilities of the soot particle moving towards the cylinder wall. Nevertheless, this will be investigated further in the future.

Acknowledgement

The authors would like to acknowledge Universiti Teknikal Malaysia Melaka (UTeM) PJP/2012/FKM(8A)/S01082 and Universiti Kebangsaan Malaysia (UKM) through GGPM-2011-055 Research Grant for supporting and funding these research activities.

References

- [1] Shah A N, Yun-shan G and Jian-wei T 2009 Carbonyls emission comparison of a turbocharged diesel engine fuelled with diesel, biodiesel, and biodieselediesel blend, *Jordan Journal of Mechanical and Industrial Engineering* **3** 111-118
- [2] Mat Yasin M H, Mamat R, Sharma K V and Yusop A F 2012 *J Mech Eng Sci* **3** 331-339
- [3] Ghobadian B, Najafi G and Nayebi M 2013 *J Mech Eng Sci* **4** 373-382
- [4] Azad A K, Ameer Uddin S M and Alam M M 2012 *Inter J Automot Mech Eng* **5** 576-586
- [5] Rahim R, Mamat R, Taib M Y and Abdullah A A 2012 *J Mech Eng Sci* **2** 226-236
- [6] Sundar Raj C and Sendilvelan S 2010 *Inter J Automot Mech Eng* **2** 144-156
- [7] George S, Balla S and Gautam M 2007 Effect of diesel soot contaminated oil on engine wear, *Wear* **262** 1113–22
- [8] Mahmood W M F W 2011 Computational Studies of Soot Paths to Cylinder Wall Layers of a Direct Injection Diesel Engine. Phd Tesis Department of Mechanical, Materials and Manufacturing Engineering, The University of Nottingham
- [9] Bonatesta F, Rocca A L, Shayler P J and Wahab E 2007 The Influence of Swirl Ratio on Soot Quantity and Distribution in the Cylinder of a Diesel Engine, *Third European Combustion Meeting ECM*
- [10] Boussouara K and Kadja M 2009 Numerical investigation of soot formation in diesel jet flame with KIVA-3V *Revue des Energies Renouvelables* **12** 55-62
- [11] Hiroyasu H and Nishida K 1989 Simplified Three-dimensional Modeling of Mixture Formation and Combustion in a D.I. Diesel Engine. *SAE Papers* 890269
- [12] Nagle J and Strickland-Constable 1962 R.F. Oxidation of Carbon Between 1000-2000°C. in *Proc of the Fifth Conf. On Carbon* (Pennsylvania State University, University Park) (Pennsylvania: Pergamon Press).
- [13] Hong S, Wooldridge M S, Im H G, Assanis D N and Pitsch H 2005 Development and application of a comprehensive soot model for 3D CFD reacting flow studies in a diesel engine. *Combustion and Flame* **143** 11-26.
- [14] Suhre B R and Foster D E 1992 In-cylinder soot deposition rates due to thermophoresis in a direct injection diesel engine *SAE Papers* **921629**.
- [15] Eduardo M, Thiago P and Fernando F 2009 An extended analysis for the dynamic of soot particle in droplet combustion, *20th International Congress of Mechanical Engineering*
- [16] Rosner D E, Mackowski D W and Garcia-Ybarra P 1991 Size and Structure Insensitivity of the Thermophoretic Transport of Aggregated Soot Particles in Gases *Combustion Science and Technology* **80** 87-101