

MOHD RAZALI SAPIEE et al: ROAD VEHICLE FOLLOWING SYSTEM WITH ADAPTIVE . . .

Road Vehicle Following System With Adaptive Controller Gain Using Model Reference Adaptive Control Method

Mohd Razali Sapiee¹ & Shahdan Sudin²¹Faculty of Electrical Engineering, UniversitiTeknikal Malaysia Melaka
mohd.razali@utem.edu.my²Faculty of Electrical Engineering, UniversitiTeknologiMalaysia
shahdan@fke.utm.my

Abstract: In order to maintain stability and satisfy operating constraints, the control system on the following vehicle needs information about the motion of preceding vehicle. A one-vehicle look-ahead control strategy is proposed and will be investigated for this operation. A mathematical model for this control strategy is obtained and simulated. This paper describes the process of designing an adaptive controller gain for a road vehicle following system. This is done through simulations and is further discussed to find the effectiveness of the method.

Keywords: one-vehicle look-ahead control, model reference adaptive control, gradient approach.

I. INTRODUCTION

In general, Malaysian drivers tend to follow another vehicle closely. Hence, platoons or convoys appeared to develop rapidly. This normally happens when spacing between vehicles is close and there is no chance for the following vehicle to overtake the preceding vehicle. The vehicle at the back or the following vehicle will have to adjust its speed and spacing with respect to the preceding vehicle. If this is not taken into careful consideration, collision between them may occur.

In order to avoid any collisions between the following vehicle and the preceding vehicle, it is necessary to maintain some safe distances between both vehicles at any speed. So, the following vehicle needs to have information regarding to the speed and the distance between them. In a normal driving, the driver of the following vehicle will estimate the information and adjust his vehicle's speed and position to have a nominal speed and a safe distance between his vehicle and the preceding vehicle.

Nowadays, all the information does not need to be estimated. Sensors are available to measure the speed of the preceding vehicle and the position of the preceding vehicle with respect to the following vehicle. The information from the sensors will be used and processed by the following vehicle controller to produce the required speed and the safe spacing distance.

This is where autonomous control can take place. The controller can automatically ensure safe distance based on

the information obtained from the preceding vehicle. The autonomous controller on the following vehicle can activate the vehicle cruise control mode, where the driver does not need to hold the steering nor press the fuel pedal, and automatically apply the brake when necessary in order to ensure the safety of the vehicle.

In developed nations, the autonomous concept leads to the Intelligent Vehicle Highway System (IVHS). A vehicle enters the highway, his vehicle automatically takes-over the control of the vehicle while following the preceding vehicle. This feature also gives rise to steeringless technology where during the autonomous control in action, the driver does not need to hold the steering wheel. All the driving tasks are taken care by the vehicle intelligent system.

One of the autonomous features is the adaptive type control based on certain control strategy which gives rise to adaptive cruise control (ACC). An ACC controlled vehicle will follow the front vehicle at a safe distance. A Model Reference Adaptive Control (MRAC) can be used in this type of control where the vehicle controller has the ability to adapt to the variation of speed and position of the preceding vehicle.



Figure 1. A vehicle following system.

II. ONE-VEHICLE LOOK-AHEAD CONTROL STRATEGY

When a vehicle follows another vehicle in front of it, a vehicle convoy or a vehicle following system is formed as shown in Fig. 1.

The following vehicle can be controlled in such a way that it will maintain either the same speed to that of the immediate preceding vehicle, which is the front vehicle or maintain a safe distance in order to avoid collision between them. This is where the string stability plays an important role by having a string stable vehicle following system. The system is said to be stable if the range errors decrease as they propagate along the vehicle stream.

In this control strategy, the controlled vehicle only refers to the information from the preceding vehicle. So, the control system on the following vehicle needs information about the motion of preceding vehicles. Yanakiev and Kanellakopoulos [1] used a simple spring-mass-damper system to demonstrate the idea of string stability and show the string-stability criterion for constant time-headway and variable time-headway policies. So from the actual diagram in Fig. 1, the vehicle following system can be represented as a mass-spring-damper analogy as shown in Fig. 2. A mathematical modeling for this control strategy is also shown in Fig. 2 where i denotes the following vehicle and $i-1$ denotes the preceding vehicle. The parameters in the above figure are vehicle mass (m),

vehicle displacement (x), vehicle acceleration (\ddot{x}), spring constant (k_p) and damper constant (k_v). The interest is only on the following vehicle. So, performing the mathematical modeling on only the following vehicle i and applying the Newton's Second law results in the following Eq. (1).

$$k_p(x_{i-1} - x_i) + k_v \frac{d}{dt}(x_{i-1} - x_i) = m_i \frac{d^2}{dt^2} x_i \quad (1)$$

Assuming unit mass for Eq. (1) and taking Laplace transform, gives the following transfer function.

$$G(s) = \frac{x_i(s)}{x_{i-1}(s)} = \frac{k_v s + k_p}{s^2 + k_v s + k_p} \quad (2)$$

The transfer function in Eq. (2) depends on the following spacing policy.

The aim of this strategy is to maintain string stability for longitudinal motion within the vehicle following system or the vehicle convoy, particularly between a vehicle with a vehicle or between a vehicle with a following vehicle. This strategy is adopted in order to design a controller by investigating the following two policies.

A. Fixed Spacing Policy

Under this policy, a fixed inter-vehicular spacing is implemented regardless of the vehicle's speed. A well-known result states that it is impossible to achieve string stability in an autonomous operation when this spacing policy is adopted. This is mainly due to the relative spacing error that does not attenuate as it propagates down the string at all frequencies. Spacing error attenuation will only occur for frequencies above a certain level. In addition, keeping the same fixed spacing at different convoy speeds would risk the safety and comfort of passengers, especially when the vehicles are closely separated.

Obviously, at higher speeds, a faster vehicle reaction time is needed in an emergency situation to avoid collision. Nevertheless, the fixed spacing policy can guarantee string stability if the front vehicle provides its information on its speed and/or position to the rear vehicle in the convoy. This can be done through radio communication or the rear vehicle having sensors to detect the above two parameters. Eq. (2) shown before is the transfer function for the fixed spacing policy.

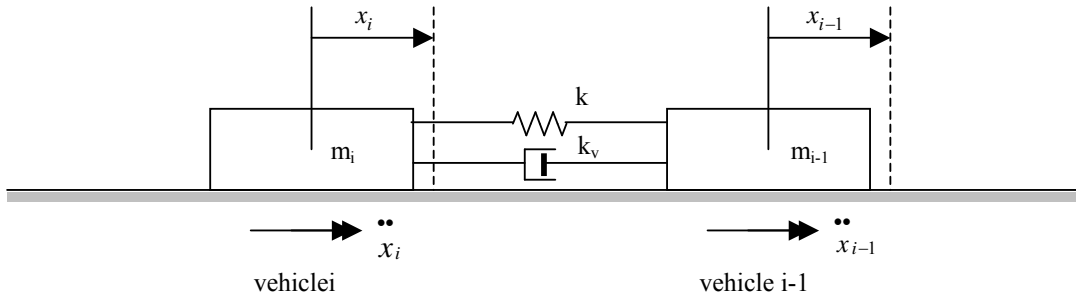

Figure 2. A mathematical model of a vehicle following system control strategy.

B. Fixed Headway Spacing Policy

This spacing policy keeps a fixed time interval, called time headway or headway, h , between the preceding vehicle and the following vehicle. It is a speed dependent policy where the inter-vehicular spacing will vary according to the preceding vehicle speed. At higher speed, vehicles will be separated in a greater distance but always maintains a fixed time interval between vehicles. Most researchers used this spacing policy in designing controllers to ensure string stability as this policy mimics the behaviour of human drivers. As vehicle speed is increased, a human driver will keep a safe inter-vehicular spacing with the immediate preceding vehicle.

The performance of the fixed headway spacing policy used in autonomous and cooperative vehicles following systems has been studied. It is found that there exists minimum possible fixed headway spacing before the string stability of convoy collapses, which is related to the actual dynamics of the vehicle. The effect of this fixed headway spacing policy is equivalent to the introduction of additional damping in the transfer function, which allows the poles of the transfer function to be moved independently from the zeros of the same transfer function. With the addition of the fixed headway spacing, Eq. (2) then becomes

$$G_1(s) = \frac{x_i(s)}{x_{i-1}(s)} = \frac{k_v s + k_p}{s^2 + (k_v + h k_p) s + k_p} \quad (3)$$

with the control law developed as

$$u_i = k_p(x_{i-1} - x_i - h v_i) + k_v(v_{i-1} - v_i) \quad (4)$$

To simplify the control law and at the same time ensure stability, a pole-zero cancellation technique is chosen. This can be achieved by introducing the constraint

$$\frac{k_p}{k_v} = h k_p \quad (5)$$

Thus,

$$\frac{1}{k_v} = h \quad (6)$$

Fig. 3 shows the pole-zero map with pole and zero cancelling each other. Through the pole-zero cancellation technique, Eq. (3) is thus reduced to

$$G_2(s) = \frac{x_i(s)}{x_{i-1}(s)} = \frac{k_v}{s + k_v} \quad (7)$$

which is a first order transfer function with a stable response with time delay. While k_v must always be positive, there exists a pole which is always in the left hand side of the s -plane. Thus, the system is always stable for this spacing policy.

C. Inclusion of Vehicle Dynamics

After proving that the fixed time headway policy is suitable to be adopted, a simplified vehicle dynamics model is introduced in order to mimic the actual vehicle internal dynamics. In this case, the external dynamics is not considered. In the simplified model, the internal dynamics is represented as a lag function i.e., the actual vehicle acceleration is obtained after a certain time delay τ . This is given by the relation in Eq. (8).

$$\tau \dot{a} + a = u \quad (8)$$

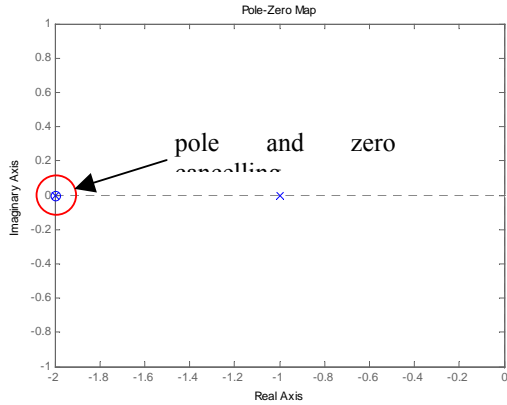

Figure 3: Pole-zero cancellation map

Eq. (3) is modified to include the vehicle dynamics part and this gives a transfer function in Eq. (9).

$$G_3(s) = \frac{x_i(s)}{x_{i-1}(s)} = \frac{k_p + sk_v}{\tau s^3 + s^2 + s(k_p h + k_v) + k_p} \quad (9)$$

Having designed the control strategy and by including the vehicle dynamics, the block diagram of the one-vehicle look-ahead vehicle following system is shown in Fig. 4.

If τ is so small (as in an ideal vehicle) i.e. $\tau \approx 0$, then $s^3 \rightarrow 0$. Hence, the transfer function is reduced back to a second order transfer function.

$$G_4(s) = \frac{x_i(s)}{x_{i-1}(s)} = \frac{k_p + sk_v}{s^2 + s(k_p h + k_v) + k_p} \quad (10)$$

Eq. (10) is then simulated by using MATLAB Simulink giving a speed input for $h=1$ s and k_p values of 0.5, 1, 2 and 3. Shown in Fig. 5 and Fig. 6 are the speed and acceleration responses, respectively. Further analysis of Fig. 5 shows that k_p value of 2 gives the best response with its acceleration response in Fig. 6 shows a maximum acceleration of about 1.4 m/s^2 . Its jerk has been analysed to show a value of about 1.9 m/s^3 , where the maximum acceptable jerk used is 5 m/s^3 [2].

III. MODEL REFERENCE ADAPTIVE CONTROL

An adaptive controller can modify its behaviour in response to changes in the dynamics of a system and the character of any disturbance. It is a controller with adjustable parameter and a mechanism for adjusting the parameter. An adaptive control system consists of two loops, normal feedback loop with plant and controller and

an adaptive parameter mechanism loop. Fig. 7 illustrates the general structure of a Model Reference Adaptive Control (MRAC) system.

The basic MRAC system consists of four main components:

- i) Plant to be controlled
- ii) Reference model to generate desired closed loop output response
- iii) Controller that is time-varying and whose coefficients are adjusted by adaptive mechanism
- iv) Adaptive mechanism that uses 'error' (the difference between the plant and the desired model output) to produce controller coefficient

Regardless of the actual process parameters, adaptation in MRAC takes the form of adjustment of some or all of the controller coefficients so as to force the response of the resulting closed-loop control system to that of the reference model. Therefore, the actual parameter values of the controlled system do not really matter.

A. The Gradient Approach

The Gradient Approach/Method of designing an MRAC controller is also known as the MIT Rule as it was first developed at the Massachusetts Institute of Technology (MIT), USA. This is the original method developed for adaptive control design before other methods were introduced to overcome some of its weaknesses. However, the Gradient method is relatively simple and easy to use.

In designing the MRAC controller, we would like the output of the closed-loop system (y) to follow the output of the reference model (y_m). Therefore, we aim to minimise the error ($e=y-y_m$) by designing a controller that has one or more adjustable parameters such that a certain cost function is minimised.

IV. ADAPTIVE CONTROLLER GAIN DESIGN

An adaptive controller gain is to be designed for the one-vehicle look-ahead control strategy with fixed time headway and vehicle dynamics by applying a Model Reference Adaptive Control (MRAC). This section presents a direct adaptive controller design which adapts the unknown vehicle parameter k_p . The advantage of the adaptive approach is that unpredictable changes in the value of k_p can be easily accommodated. Figure 8 on the other hand shows the one-vehicle look-ahead control strategy based controller with the gain parameter to be adjusted, k_p is the gain adjustment mechanism to be designed in the control strategy.

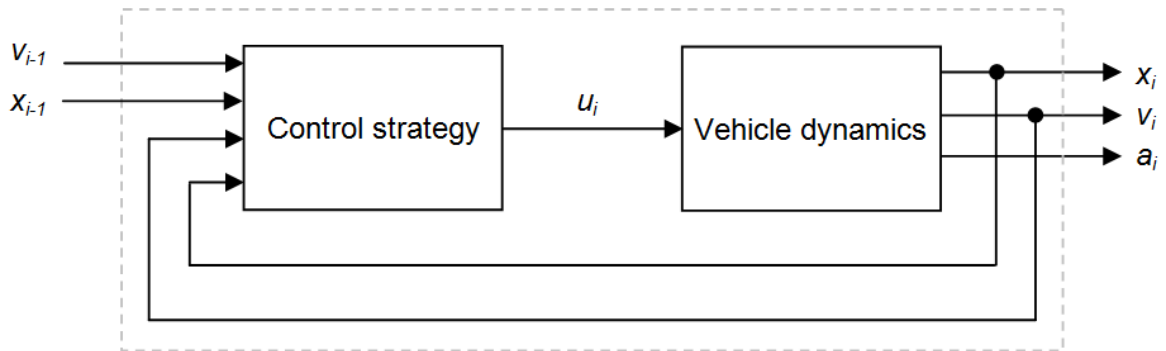

Figure 4. Block diagram consisting of the control strategy and vehicle dynamics.

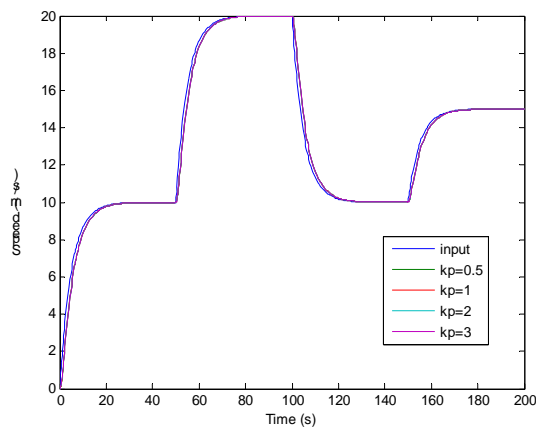

Figure 5. Speed response of fixed headway with various k_p values.

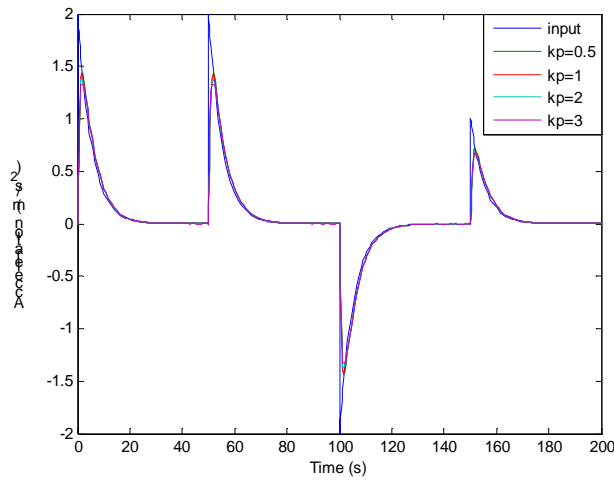

Figure 6. Acceleration response of fixed headway with various k_p values.

A. The Gradient Approach Design

From the analysis of Fig. 6, k_p value of 2 gives the best response. So, it will be used in Eq. (10) to give a reference model to be used in designing the adaptive controller gain.

The vehicle dynamic has been included in the control law to form the plant.

Plant:

$$y = \frac{s + k_p}{s^2 + (1 + k_p)s + k_p} r \quad (11)$$

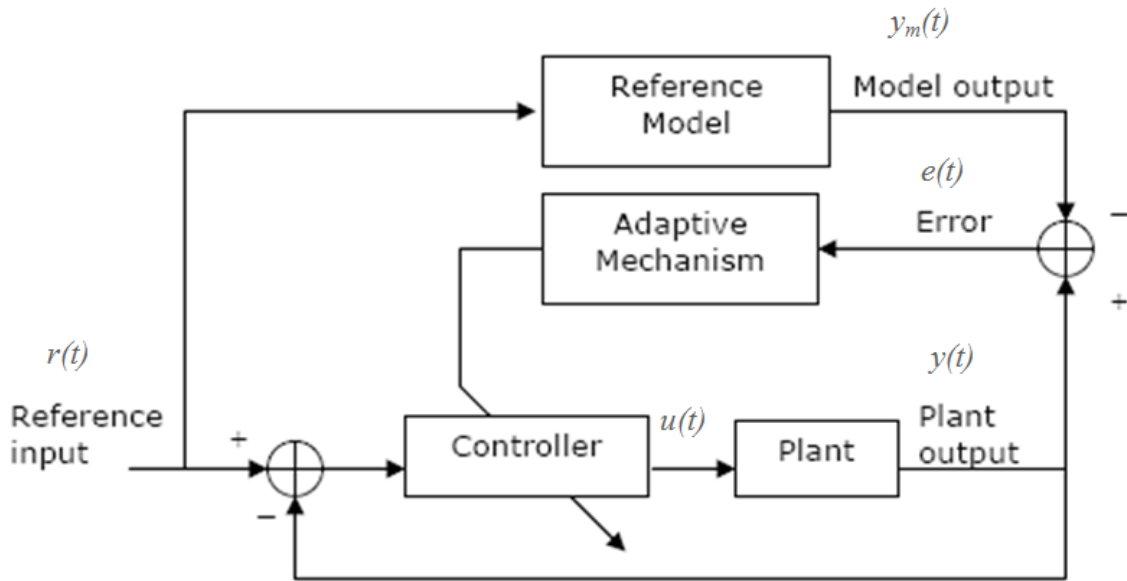

Figure 7. General structure of an MRAC system.

Reference model:

$$y_m = \frac{s + 2}{s^2 + 3s + 2} r \quad (12)$$

A closed-loop system with a controller has the following parameters:

$r(t)$ = Reference input signal

$u(t)$ = Control signal

$y(t)$ = Plant output

$y_m(t)$ = Reference model output

$e(t)$ = Difference between plant and reference model output
 $= y(t) - y_m(t)$

The control objective is to adjust the controller parameters, θ , so that $e(t)$ is minimised. To do this, a cost function, $J(\theta)$ is chosen and minimised. The cost function chosen is of the form

$$J(\theta) = \frac{1}{2} e^2 \quad (13)$$

Let $\theta = k_p$ and replacing it into Eq. (11), thus

$$y = \frac{s + \theta}{s^2 + (1 + \theta)s + k_p} r \quad (14)$$

Therefore the error,

$$e = y - y_m$$

$$= \frac{s + k_p}{s^2 + (1 + k_p)s + k_p} r - \frac{s + 2}{s^2 + 3s + 2} r$$

So we have,

$$\frac{d\theta}{dt} = -\gamma e \left[\frac{r - y(s + 1)}{s^2 + (1 + k_p)s + k_p} \right]$$

In this case we need to do some approximation: i.e. perfect model following, $y = y_m$. Therefore, we then have,

$$\begin{aligned} \frac{d\theta}{dt} &= -\gamma e \left[\frac{r - y(s + 1)}{s^2 + 3s + 2} \right] = -\gamma e \left[\frac{y_m - y}{s + 2} \right] \\ \theta &= -\frac{\gamma}{s} e \left[\frac{y_m - y}{s + 2} \right] = -\frac{\gamma}{s} e^2 \left(\frac{1}{s + 2} \right) \end{aligned}$$

This results in,

$$k_p = -\frac{\gamma}{s} e^2 \left(\frac{1}{s + 2} \right) \quad (15)$$

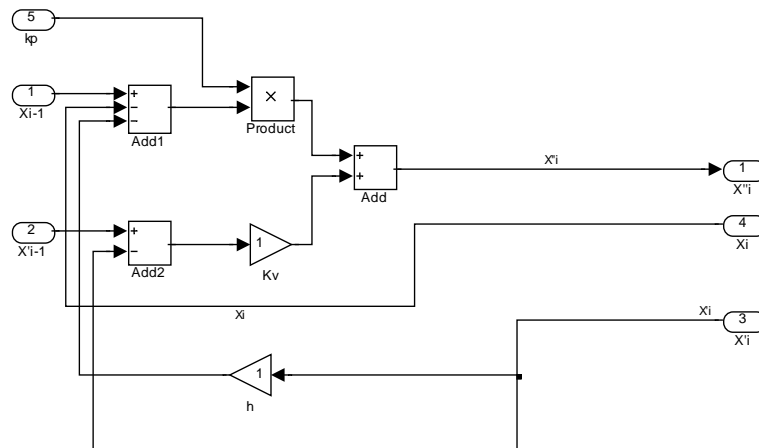

Figure 8. A one-vehicle look-ahead controller with adjustable gain.

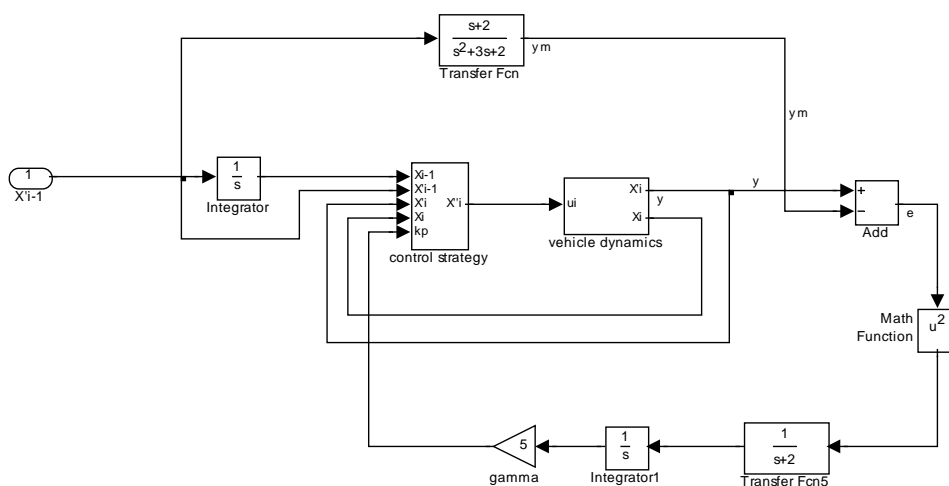

Figure 9. The gradient approach adaptive controller gain simulation diagram.

The closed-loop system block diagram obtained is shown in Fig. 9 where γ in the equations is denoted by gamma in the simulation diagram. The red dotted line indicates the adaptive mechanism.

The MRAC gradient approach adaptive controller gain design is then simulated again using MATLAB Simulink. Both the output of the system responses (y and y_m) are shown in Fig. 10 and Fig. 11. Fig. 10 shows a perfect model following output while Fig. 11 on the other hand

shows the acceleration response of y where it does not follow a sharp change in input acceleration.

It can be seen that the output response for plant y perfectly follows the reference model y_m . It can be said that the system is a perfect model following system. The adaptive controller gain is again simulated but this time with γ values of 1, 10, 100 and 1000.

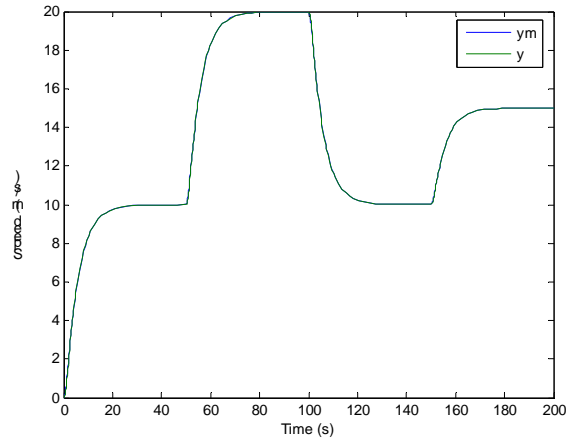

Figure 10. Comparison of y and y_m for speed from the gradient approach.

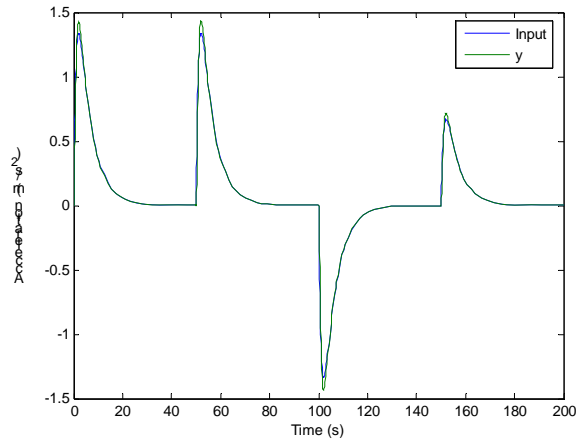

Figure 11. Comparison of y and y_m for acceleration from the gradient approach.

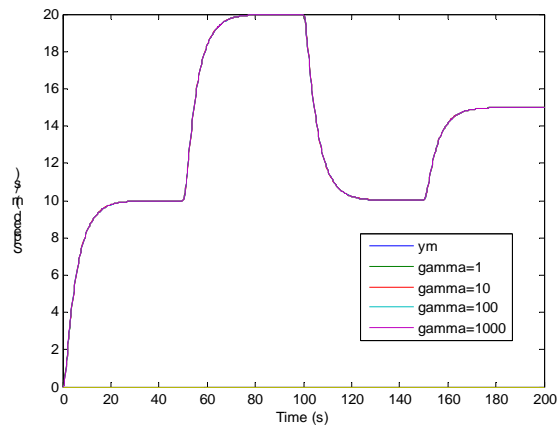

Figure 12. Speed response with various γ values for adaptive controller gain.

Shown in Fig. 12 and Fig. 13 are the speed and acceleration responses for the adaptive controller gain, respectively. Further analysis of Fig. 13 shows that γ value of 100 gives the best response by almost fitting the reference model with smooth curve. Using γ value

of 1000 produces some ripples when there is no acceleration.

V. RESULTS AND DISCUSSION

A one-vehicle look-ahead control strategy with fixed headway policy has been adopted in designing a controller to produce an output, which can respond immediately to the change in input; in this case, the input is the speed with varying speed conditions. With

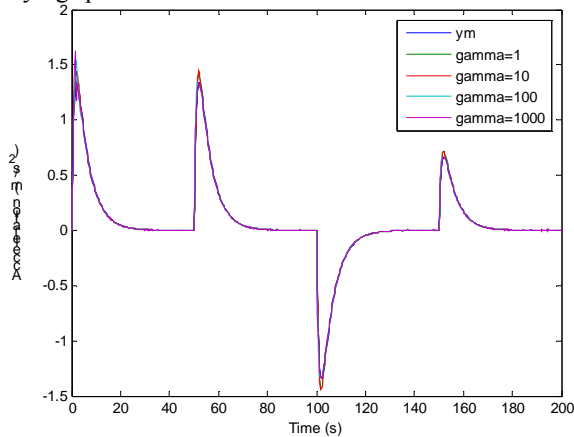

Figure 13. Acceleration response with various gamma values for adaptive controller gain.

normal controller, the response does not quite match perfectly with the input. With the introduction of the MRAC adaptive controller gain, the response can be made to follow the input by choosing a suitable reference model. Furthermore, using MRAC adaptive controller gain produces a smooth output as compared to the other one.

VI. CONCLUSION

The adaptive controller gain tuning has been investigated using Model Reference Adaptive Control concepts and the gradient approach. Simple adaptation law for the controller parameters has been presented assuming that the process under control can be approximated by a second order transfer function. The developed adaptation rule has been applied and simulated. The results obtained show the effectiveness of the technique. The resulting performance could be improved by a better choice of the length of the adaptation period.

The gradient approach is known to have its disadvantages; the speed of adaptation depends on the values of the command signal. This problem is often dealt with by using a normalised adaptation rule. Second, the gradient approach does not guarantee the stability of the nominal system. The Lyapunov approach can be used to provide guaranteed nominal stability.

A further limitation of the approach is the assumption of a structure for the nominal system. In this paper, a second order transfer function has been assumed resulting from the assumption of a very small time delay between the command signal and the vehicle dynamics as in ideal

vehicle. Further investigation on the comparison with other control strategies will be done in future papers.

ACKNOWLEDGMENTS

The authors would like to acknowledge their gratitude to Faculty of Electrical Engineering, Universiti Teknologi Malaysia for providing the resources and support in the completion of this paper.

REFERENCES

- [1] D. Yanakiev and I. Kanellakopoulos, "A Simplified Framework for String Stability Analysis in AHS," Proc. of the 13th IFAC World Congress, 1996, pp.177-182.
- [2] D. N. Godbole and J. Lygeros, "Longitudinal Control of the Lead Car of a Platoon", IEEE Transactions on Vehicular Technology, 1994, vol. 43, no. 4, pp. 1125-1135.
- [3] P. A. Cook and S. Sudin, "Dynamics of Convoy Control Systems", 10th IEEE Mediterranean Conference on Control and Automation, July 2002.
- [4] S. Sudin and P. A. Cook, "Dynamics of Convoy Control Systems with Two-Vehicle Look-Ahead Strategy, International Conference on Robotics, Vision, Information and Signal Processing, 2003, pp. 327-332.
- [5] P. A. Cook and S. Sudin, "Convoy Dynamics with Bidirectional Flow of Control Information, 10th IFAC Symposium on Control in Transportation Systems, 2003, pp. 433-438.
- [6] S. Sudin and P. A. Cook, "Two-Vehicle Look-Ahead Convoy Control Systems, 59th IEEE Vehicular Technology Conference, vol. 5, 2004, pp. 2935-2939.
- [7] S. Sudin, Dynamics and Control of Vehicle Convoy Systems, PhD Thesis, School of Electrical and Electronic Engineering, Faculty of Engineering and Physical Sciences, The University of Manchester, 2005.
- [8] C. Y. Liang and H. Peng, "Optimal Adaptive Cruise Control with Guaranteed String Stability", Vehicle System Dynamics, vol. 31, 1999, pp. 313-330.
- [9] K. Pirabakaran, V. M. Becerra, "Automatic Tuning of PID Controllers using Model Reference Adaptive Control Techniques", The 27th Annual Conference of The IEEE Industrial Electronics Society, 2001, pp. 736-740.
- [10] M. R. Sapiee, H. Selamat, A. Noordin, A. N. Jahari, "PI Controller Design using Model Reference Adaptive Control Approaches for a Chemical Process", Proceedings of 2008 Student Conference on Research and Development, 2008, pp. 155-1 to 155-4.