

Development and Modeling of Water Tank System Using System Identification Method

M.S.M Aras, M.F. Basar, N. Hasim, M.N. Kamaruddin, H.I. Jaafar

Abstract— This paper presents the development and modeling of Water Tank System (WTS) for temperature control using system identification technique. The WTS consists of the tank with 30 liter water, a stirrer, heater and thermocouple was powered by 240VDC and the system run by LabView software. The stirrer used to stabilize the water temperature that installed on the top cover of the WTS. In this project, a prototype of the WTS will be developed first. The WTS will be tested on an open loop system to obtain measured input-output signals. Input and output signals from the system are recorded and analyzed to infer a model. Then, system identification toolbox in MATLAB will be applied to generate a model of the WTS. The experimental testing of WTS only considered in temperature control. The modeling obtained will be used to design the a suitable controller for temperature control. The most crucial issue is the control system. It is needed for the WTS to perform the desired temperature setting. The objective of this project is to reduce or eliminate the overshoot of system response from temperature setting. The conventional controller PID and Fuzzy Logic Controller (FLC) will be used to control the temperature so that the temperature will maintain its desired temperature. The result shows that FLC is the better performance of system response in term of overshoot and oscillation.

Index Terms—Water Tank System (WTS), Temperature Control, Fuzzy Logic Controller (FLC), PID Controller

I. INTRODUCTION

In control system, there are many types of controller design from traditional, conventional and even modern controller (the hybrid controller and more intelligence controller) can be used as shown in Fig. 1. The research of conventional controller such as PID Controller and Intelligent controller like Fuzzy Logic Controller (FLC) are the most controllers that always use in industrial control because of easy and simple to implement [1]. PID Controller also known as a conventional controller used to tune the temperature controller which involves proportional, integral and derivative parameters to get the best possible control of process control system using the auto-tuned to obtain optimum parameter [2]. A new technique proposed to tune the PID parameter using Particle Swarm Optimization (PSO) by [3- 5]. The FLC is a well-known intelligent controller that tune using membership function 3x3 matrix rules and default 3x3 matrix rules. Fuzzy Logic is a general logical system.

Manuscript received August, 2013.

M.S.M. Aras, Faculty of Electrical Engineering (FKE), Universiti Teknikal Malaysia Melaka (UTeM), Malaysia .

M.F. Basar, Faculty of Engineering Technology (FTK), Universiti Teknikal Malaysia Melaka (UTeM), Malaysia.

N. Hasim, Faculty of Electrical Engineering (FKE), Universiti Teknikal Malaysia Melaka (UTeM), Malaysia.

M.N. Kamaruddin, Faculty of Electrical Engineering (FKE), Universiti Teknikal Malaysia Melaka (UTeM), Malaysia.

H.I. Jaafar, Faculty of Electrical Engineering (FKE), Universiti Teknikal Malaysia Melaka (UTeM), Malaysia.

The greater generality of fuzzy logic is needed to deal with complex problems in the realms of search, question-answering decision and control. Fuzzy Logic provides a foundation for the development of new tools for dealing with natural languages and knowledge representation. The basic fundamental of FLC can be referred [6 –11].

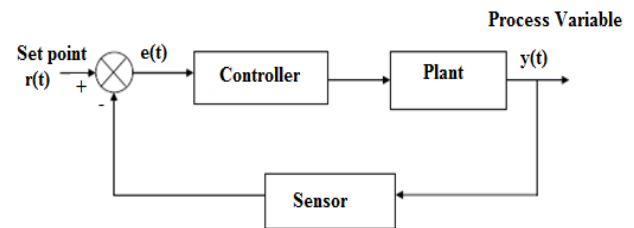

Figure 1: Control System

This research is inspired from previous research and can be found in [12-17]. In [12 -13] presents the development of a water bath control system for a virtual laboratory environment and control using wireless technique. While [14] water bath system temperature controller using MATLAB software. For this research a water tank system with tank can fill up to 30 liter water was powered by direct current 240V and the system run by LabView system will be set up. The WTS consists of a stirrer, heater and thermocouple as shown in Fig. 2. The stirrer used to stabilize the water temperature that installed on the top cover of the WTS. The sensor used in this system was thermocouple type RTD Thermocouple PT100. A heater used in this WTS was Immersion Heater 3kW, 240V. Temperature reading was obtained by using two components that are NI USB 6008 and thermometer to measure the temperature. Data sheet of NI USB 6009 can be referred [18]. Software that has been used for collecting data from hardware is LabView Signal Express.



Figure 2: Water Tank System

The WTS will be tested on an open loop system to obtain measured input-output signals. Input and output signals from the system are recorded and analysed to infer a model. Then, system identification toolbox in MATLAB will be applied to generate a model of the WTS. The experimental testing of WTS only considered in temperature control. The modelling obtained will be used to design the suitable controller for

temperature control. The both controllers PID Controller and FLC will be used in this project to select the best performances. The MATLAB System Identification toolbox is used to generate the model in transfer function form of WTS as the plant before designing a suitable controller. FLC designed with tuned 3x3 matrix rules will be compared with the default 3x3 matrix rules and analyze the best performance in term of overshoot in system response. The conventional PID controller was adjusted using auto-tuned to obtain optimum for every parameter. Comparative FLC performances will be made mainly on overshoot of the system response with PID Controller.

II. METHODOLOGY

The methodology as shown in Fig. 3 was divided into 3 parts which are modeled the WTS in transfer function form using system identification, design conventional PID controller using auto-tune and manual selected for controller parameter and FLC and finally compare the performances between both controllers.

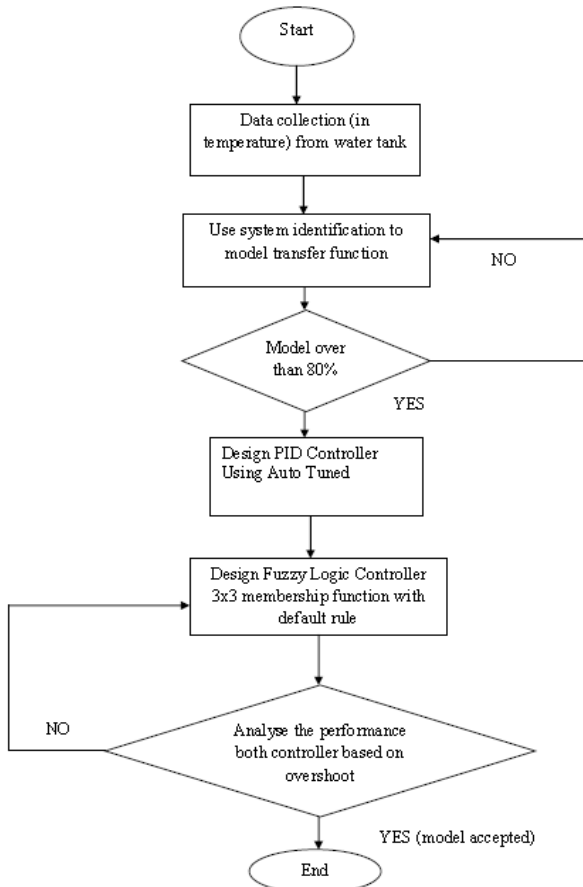

Figure 3: Flow Chart

Part 1 is a WTS hardware development. The hardware development of WTS is includes stirrer to stabilize the temperature of the WTS. The stirrer works with a motor that installed on the top cover of the tank. The motor will be run once the switch of the tank is “ON” and trigger by NI USB 6009, simultaneously. The heater starts to pre-heat when the switch is ON and stirrer will function simultaneously. When the process is running, the NI USB 6009Card has been connected to a laptop using LabView Signal Express software to record the temperature data. The process runs in up to 1 hour and the temperature achieved until 100° C. This experiment has been done using three different set point

values (50°C, 55°C and 60°C) to get more data to be analyzed for better performance. After the data has been obtained, the System Identification MATLAB Toolbox was used in order to infer a model of the WTS in transfer function form as a plant for this system. In this process, the best model is a model that obtained the best performance with the best fit over than 80 per cent and then applies controller to achieve 100 percent performances. The modeling obtained will be used to design the suitable controller for temperature control. It is needed for the WTS to perform the desired temperature setting.

Next is a designing FLC in membership function 3x3 matrix rules. For this part, the system was built in the MATLAB Fuzzy Logic Toolbox. Membership function with 3x3 matrix rules and using default 3x3 matrix rules will be used. Set point (55°C) has been set in unit step as input. The FLC designed will be tuned in membership function 3x3 matrix rules and rule based till it is obtained a better performance in system response. Then compare with the defaults 3x3 matrix rules are made. Conventional PID Controller using auto-tuned and manual tuned in MATLAB Simulink to make comparing the performances of the system response in term overshoot, rise time and settling time with FLC. The final part in this project is to analyze performances of the both controllers which one was a better performance based on objective.

A. System Identification

System identification is process developing or improving the mathematical representation of a physical system using experimental data. System identification was a system that usually was used in a control system. Especially for modeling transfer function for any plant system. This system was well-known as an art and science of building a mathematical model of a dynamic system from observed input output data [16].

Historically, system identification originates from an engineering need to form models of dynamical systems: it then comes as no surprise that traditionally emphasis is laid on numerical issues as well on a system-theoretical concern [19 20]. For System Identification method, the development of WTS will be considered first and will be referred as platform development. Fig. 4 shows a typical approach in implementing system identification to an observation of a dynamic system.

Generally, the system identification approach goes through five steps [19], such as (1) design parameter, (2) platform design, (3) model selection, (4) model generated and (5) model verify. At step 4, if the model is not good enough, steps 3, 2 or 1 may need to be repeated. The first stage is design parameter that to decide on the design parameters, the dynamic equation must be familiarized.

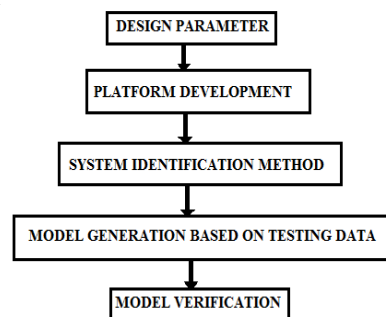

Figure 4: System Identification Approach

After identifying the design parameter, the next stage is platform development. In this stage, the prototype of a WTS will develop based on design parameters. System identification will take place once the platform is ready to be tested to get input-output signals. The MATLAB System Identification Toolbox will be used to infer a model. Some theory for System Identification must be cleared so that the model obtained is acceptable. Then the model obtained from System Identification will be verified using a simple controller such as conventional PID controller.

B. PID Controller

Modeling of the WTS in transfer function form after getting the best model with good best fit done, the model was applied in the plant of the system. For this part PID controller design with auto tuned to get the response with performances with an overshoot, rise time and settling time. In Figure 5, the PID system was built with the model transfer function as a plant for this system in Simulink. From the experimental set up, 3 different set point will be set up which is 50° C, 55°C and 60°C. For every set point we refer to best fit to decide to model of WTS which is achieved over than 80% best fit. The lower overshoot among PID Controller result is selected as a WTS plant to compare with FLC. The PID block can be ‘auto-tuned’ automatically using MATLAB 2009 and onwards. The system launching PID Tuner and the system will tune parameter of PID controller with the best value and performances Proportional, Integral and Derivative.

C. Fuzzy Logic Controller

The FLC is a well-known intelligent controller that tune using membership function 3x3 matrix rules and default 3x3 matrix rules. In this project, comparison the result of 3x3 matrix control rules and the default 3x3matrix control rules will be investigated. The number of rules is increasing to observe the effect of the different fuzzy control rules on the

performances. Fuzzification is the first stage of the fuzzy logic controller process. This process converts controller inputs into information that the inference mechanism can easily use to act and apply rules. At this stage, the crisp input values are converted to the fuzzy input values. In this FLC, two input variables have been defined which are temperature and temperature error as shown in Fig. 6 (a), (b) and (c). Meanwhile the output of this FLC is a voltage as shown in Fig. 6 (d). This fuzzy logic controller design for 3x3 the defaults fuzzy control rules as shown in Table 1. This FLC is using “mamdani” method.

Table 1: The default 3x3 matrix control rules

		Error		
		Cold	Warm	Hot
Delta Error	Cold	Cold	Cold	Hot
	Warm	Cold	Warm	Hot
	Hot	Cold	Hot	Hot

III. RESULTS AND DISCUSSION

In this section, all the result has been found for this project will be presented. The modeling using System Identification based on data obtained from experimental will be discussed. A command used for System Identification toolbox to get the transfer function form.

A. System Identification

Based on results obtained, the lower overshoot among PID Controller result is selected as a WTS plant to compare with FLC. The PID Controller with transfer function in set point 55°C was selected. Figure 7 shows the output for this model with best fit 94.12% which more than 80% that we clarify as best model where the set point is 55°C. And this model has accepted.

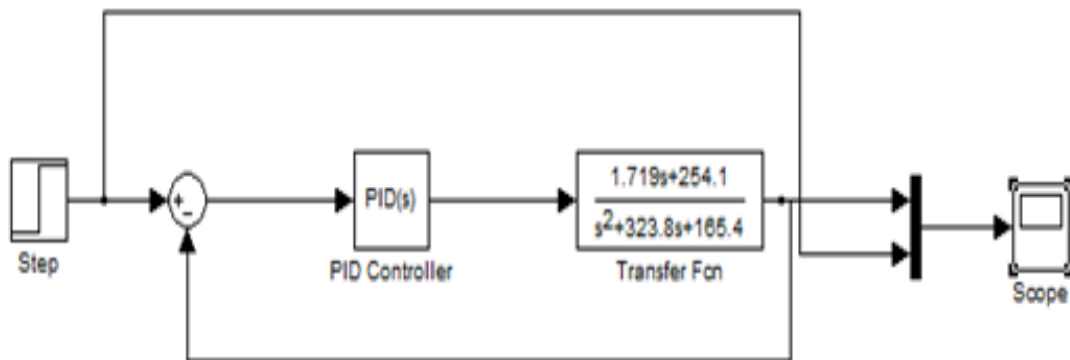
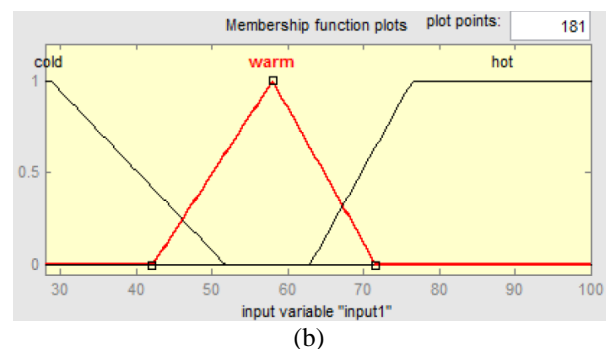
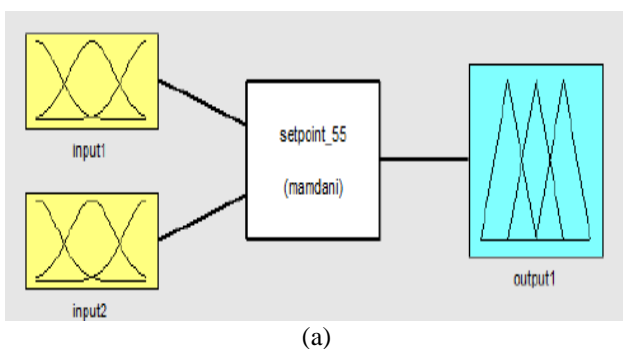
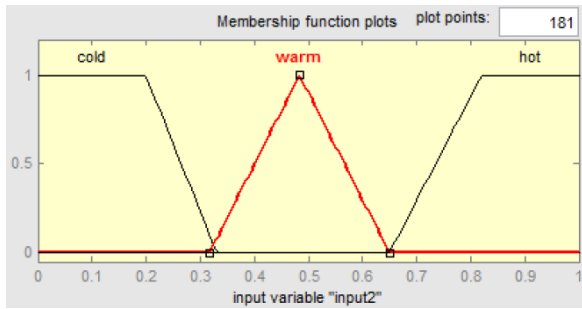
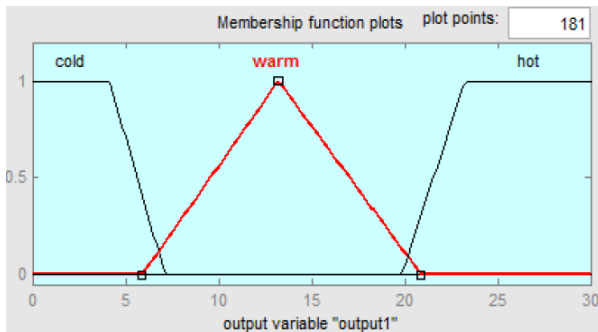

Figure 5: Simulink for Model of WTS using PID Controller





(c)



(d)

Figure 6: FLC Design in MATLAB Fuzzy Logic Toolbox

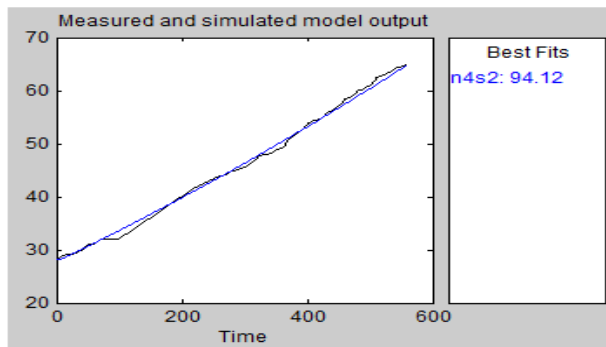

Figure 7: Best Fits for WTS model

Then, the transfer function is:

$$Gs = \frac{1.719s + 254.1}{s^2 + 323.8s + 165.4}$$

Fig. 8 shows the PID Controller performances for system response tuning using auto-tuned. The graph shows the overshoot for this system was 9.18% at 2.68s.

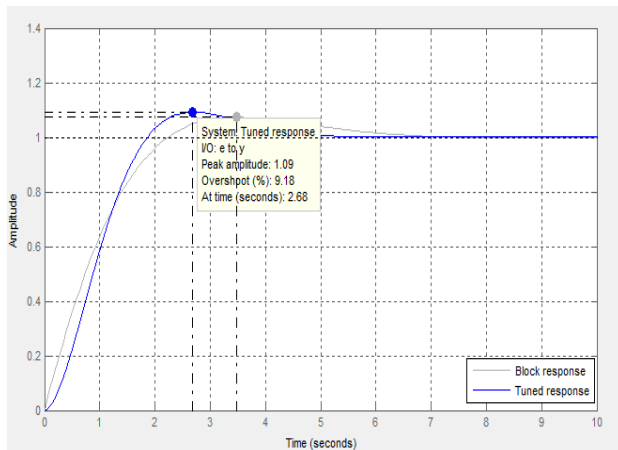

Figure 8: System response of WTS using PID controller

Fig. 9 shows the settling time achieved in 4.42s. Settling time was the required for transient response damped reach and stay within (+/-2%) of the set point. Figure 10 shows Fuzzy Logic Controller response default 3x3 rules. Same as in the previous section, this is one of step tuning in Fuzzy Logic membership function 3x3 matrix rules. Default rule was a common rule that was used in Fuzzy Logic Controller due to faster implementation and standard for all systems before modification.

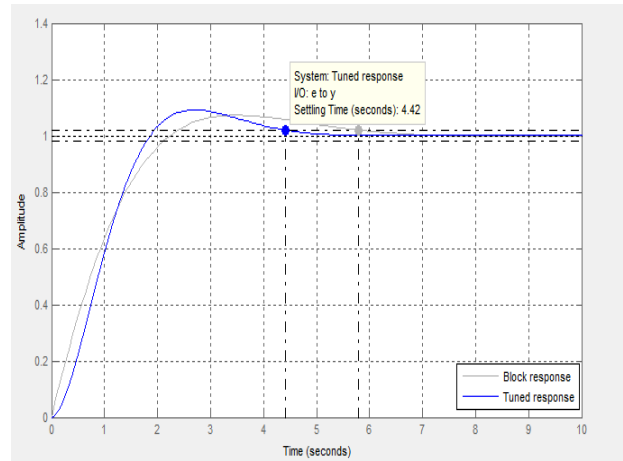

Figure 9: PID Controller Settling Time (Ts)

Fig. 10 shows Fuzzy Logic Controller response with membership function 3x3 with default rules. Based on graph system response of FLC, it shows that this system has no overshoot which is the system achieved with zero overshoot. On the other side, this response graph also shows the response for settling time, Ts, and rise time, Tr. In settling time, based on [2], settling time was the time required for the transient damped to reach and stay with +/-2% of the final value 55°C. In settling time, Ts, for this response was on 7.63s. For rise time, Tr, based on [2], rise time was between 0.1 and 0.9 from final value 55°C. The rise time, Ts, for this response was on 4.28s.

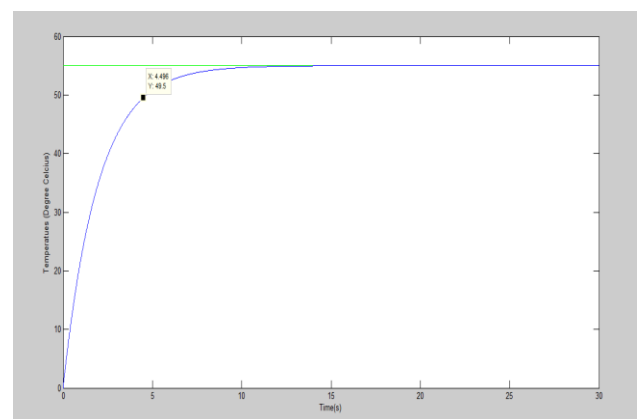

Figure 10: Fuzzy Logic Controller response with membership function 3x3 with default rules

The final part was an analysis part which is a comparison between PID Controller and Fuzzy Logic Controller. Table 2 shows the characteristic performance for both controllers. Based on PID Controller performances, the system has an overshoot which not too big but still have 9.18%. For rise time, the system was on 4.42s. And settling time was on 1.25s.

For Fuzzy Logic, there is no overshoot which means that Fuzzy Logic Controller response for overshoot was zero. The settling time for Fuzzy Logic Controller was 7.6s and the rise time, was 4.28s.

Table 2: Characteristic performance for both controllers

PID Controller	Fuzzy Logic Controller
Overshot : 9.18%	Overshot : zero (0)
Settling Time (Ts) : 4.42s	Settling Time (Ts) : 7.63s
Rise Time (Tr) : 1.25s	Rise Time (Tr) : 4.28s

Table 2 shows the result performance for PID Controller and Fuzzy Logic Controller. From the table, PID Controller has lower settling time, Ts which is 4.4s compare to Fuzzy Logic was on 7.63s. For rise time, Tr, PID Controller achieved in 1.25s which are also less lower than the Fuzzy Logic Controller. But, for overshoot, Fuzzy Logic was much better than PID Controller which Fuzzy Logic Controller has no overshoot (zero overshoot) compare to PID Controller which has 9.18% overshoot. It means, it has proved that Fuzzy Logic was a better controller than PID Controller based on the performances of overshoot parallel with objective where the objectives is to reduce or eliminate overshoot. For PID controller the overshoot is 9.18% from set point, it was about $\pm 5.049^{\circ}\text{C}$. The overshoot is high and the system wasn't following the set point with final value 55°C where the peak value is about 60.049°C . Compare to FLC, no overshoot occurred meaning that the system follows the response without error. Even though the rise time and settling time for Fuzzy Logic Controller is quite slower than PID Controller, but it was not worst, because, the delay time has been just 3s only.

IV. CONCLUSION

In this project, modeling of WTS using system identification was successfully obtained. Start from getting data from the hardware of WTS and record all the data. The MATLAB System Identification toolbox was used to infer a model in the transfer function form and can conclude the best result was a model with the best fit over than 80%. From the data, it was set in 3 different set point which is 50°C , 55°C and 60°C . Based on experimental results, the entire model was achieved over than 80% which is can conclude that the modeling was achieved. Designing a controller was started on the conventional PID Controller. All the transfer function was applied in PID Controller to get the best transfer before selecting and declare as a WTS plant to control the system. PID Controller used to control all the transfer function and tuning using auto-tuned to obtain every parameter of the controller. Based on results obtained, the lower overshoot among PID Controller result is selected as a WTS plant to compare with Fuzzy Logic Controller. The PID Controller with transfer function in set point 55°C was selected. This because, overshoot for this PID was lower than the other which 9.18% only, the rise time was 1.25s and settling time was 4.42s. And the best fit of this model exactly over than 80% which was 94.12%.

The Fuzzy Logic Controller was tuned with membership function 3x3 matrix rules and using 3x3 default rules successfully done. The result of FLC shows the response has no overshoot. Even the results has higher rise time and settling time compare to PID Controller, but we can conclude that

FLC is the best controller for WTS in term of overshoot because meet the objective. Overshoot in the system was important to be considered deeply because in controller system design, main focus that is to achieve zero overshoot. Based on PID Controller overshoot 9.18% than the final value 55°C , meaning that it was about 5.049. So the final performances the system will be error about 60.049°C which is higher than set point. Finally, the conclusion is the performances of Fuzzy Logic Controller were better than the PID Controller and achieved good performances with no overshoot.

ACKNOWLEDGMENT

Special appreciation and gratitude to the Universiti Teknikal Malaysia Melaka (UTeM) especially to the Faculty of Electrical Engineering and Faculty of Engineering Technology for providing the financial as well as moral support to complete this project successfully.

REFERENCES

- [1] Mohd Shahrieel Mohd Aras, SN Bin Syed Salim, Eric Chee Sai Hoo, M Hendra Hairi, Comparison of Fuzzy Control Rules Using MATLAB Toolbox and Simulink for DC Induction Motor-Speed Control, IEEE International Conference of Soft Computing and Pattern Recognition, 2009. SOCPAR'09, pp 711-715.
- [2] Norman S.Nise, Control Engineering System 6th Edition, California State Polytechnic University, Pomona, John Wiley & Son Inc. 2011.
- [3] Hazriq Izzuan Jaafar, Z. Mohamed, Amar Faiz Zainal Abidin, Z. Ab Ghani, PSO-Tuned PID Controller for a Nonlinear Gantry, Crane System, IEEE International Conference on Control System, Computing and Engineering, 23 - 25 Nov. 2012, pp 1-5.
- [4] Hazriq Izzuan Jaafar, Nursabilillah Mohd Ali, Z. Mohamed, Nur Asmiza Selamat, Anuar Mohamed Kassim, Amar Faiz Zainal Abidin, J.J. Jamian, Optimal Performance of a Nonlinear Gantry Crane System via Priority-based Fitness Scheme in Binary PSO Algorithm, pp 1 -6, 2013.
- [5] M.S.M Aras, S.S. Abdullah, H.I. Jaafar, A. A Rahman, M.A.A Aziz, Single Input Fuzzy Logic Controller tuning using PSO based on Simple Feed Forward and Output Feedback Observer for Underwater Remotely Operated Vehicle, Submitted to related journal (under review), 2013.
- [6] Reza Talebi-Daryani, Markus Olbring "Application Of Fuzzy Logic Control For Energy Management Of a Cascaded Heating Centre", University of Applied Sciences Cologne/Germany, Sviences-Landis & Staefa/Cologe Germany, pp.1-8
- [7] Mohd Shahrieel bin Mohd Aras, FBA Azis, SMSBS Hamid, FAB Ali, SSB Abdullah, Study of the effect in the output membership function when tuning a Fuzzy Logic Controller, IEEE International Conference on Control System, Computing and Engineering (ICCSCE), pp 1-6, 2011.
- [8] B.J LaMeres, M.H. Nehrir, V.Geres "Controlling The Average Residential Electric Water Heater Power Demand Using Fuzzy Logic", Electrical & Computer Engineering Department Montana State University, Bozeman, MT 59717.
- [9] Yunseop Kim "Fuzzy Logic Temperature Controller", Physics 344 Fall 2001 Project Report, Physics Department, University of Illinois at Urbana-Champaign, pp 2-12
- [10] Vjekoslav Galzina, MsC, Tomislav Saric, PhD, Roberto Lujic, PhD "Application Of Fuzzy Logic in Boiler Control", University J.J Strossmayer in Osijek, Mechanical Engineering Faculty in Slavonski Brod, pp.15-21
- [11] Manis Agarwal, "Fuzzy Logic Control in Washing Machines", Roll Number 00ME1011, Department of Mechanical Engineering, India Institute of Technology, Kharagpur, pp.1-5
- [12] N Hasim, MF Basar, MSM Aras, "Design and Development of a Water Bath Control System: A Virtual Laboratory Environment," 2011 IEEE Student Conference on Research and Development (SCORED), pp. 403-408, ISBN: 978-1-4673-0099-5, Cyberjaya, Malaysia, 19-20 December 2011.
- [13] MSM Aras, MKA Rahim, A Asrokin, MZA Abdul Aziz, Dielectric resonator antenna (DRA) for wireless application, IEEE International RF and Microwave Conference (RFM 2008), Pages 454-458, 2008.

- [14] Norhaslinda Hasim, Mohd Shahrieel Mohd Aras, Mohd Zamzuri Ab Rashid, Anuar Mohamed Kassim, Shahrum Shah Abdullah, Development of fuzzy logic water bath temperature controller using MATLAB, IEEE International Conference on Control System, Computing and Engineering (ICCSCE), pp 11 – 16, 2012.
- [15] M.F. Basar, A. Ahmad, N. Hasim and K. Sopian, "Introduction to the Pico Hydropower and the status of implementation in Malaysia," IEEE Student Conference on Research and Development (SCOREd), pp. 283-288, ISBN: 978-1-4673-0099-5, Cyberjaya, Malaysia, 19-20 December 2011.
- [16] M.F. Basar, A.A. Rahman, Z Mahmod, "Design and Development of Green Electricity Generation System Using Ocean Surface Wave," PEA-AIT International Conference on Energy and Sustainable Development : Issues and Strategies (ESD 2010), pp. 1-11, ISBN: 978-1-4244-8563-5, Chiang Mai, Thailand, 02-04 June 2010.
- [17] MSM Aras, H.A. Kasdirin, M.H. Jamaluddin, M F. Basar, Design and Development of an Autonomous Underwater Vehicle (AUV-FKEUTeM), Proceedings of MUCEET2009 Malaysian Technical Universities Conference on Engineering and Technology, MUCEET2009, MS Garden, Kuantan, Pahang, Malaysia, 2009.
- [18] "User Guide And Specifications NI USB 6008/6009", Bus-Power Multifunction DAQ USB Device.
- [19] Mohd Nasir Taib, Ramli Adnan, Mohd Hezri Fazalul Rahiman, "Practical System Identification ", Faculty of Electrical Engineering, Universiti Teknologi MARA, 40450, Shah Alam, Malaysia.
- [20] Lennart Ljung "Perspectives on System Identification", Division of Automatic Control.



Mohd Shahrieel b Mohd Aras is a lecturer at Faculty of Electrical Engineering, Universiti Teknikal Malaysia Melaka (UTeM). He currently pursues his PhD in Control and Automation at Universiti Teknologi Malaysia, Skudai, Johor. His currently research is focusing on control system design of underwater technology. (shahrieel@utem.edu.my)



Norhaslinda Hasim is a lecturer at Faculty of Electrical Engineering, Universiti Teknikal Malaysia Melaka. She received the Bachelor of Engineering with Honours (Electrical) (UiTM) and Master in Electrical Engineering (Control) in UTM. Her primary interests related to Control, Instrumentation & Automation.



M.F Basar obtained his Degree in Electrical Engineering from UTM, Johor, Malaysia. His major field of study is renewable energy technologies. He has an experience as Research and Development (R&D) Engineer in electrical power industries and now he is working as a Lecturer in Universiti Teknikal Malaysia Melaka (UTeM). (mfarriz@utem.edu.my)



Muhammad Nizam Kamarudin received the B.Eng. Electrical (2001) from the Universiti Teknologi MARA and M.Sc. Automation and Control (2007) from the University of Newcastle Upon Tyne, United Kingdom. Currently he is with the Universiti Teknikal Malaysia Melaka (UTeM) and now working for his Ph.D research at the Universiti Teknologi Malaysia (UTM). His primary interests related to nonlinear robust control systems.



Hazriq Izzuan b Jaafar is a lecturer at Faculty of Electrical Engineering, Universiti Teknikal Malaysia Melaka. He received the M. Eng (Electrical - Mechatronics and Automatic Control), and B.Eng (Electrical - Power), from UTM. His interest in Control Systems Engineering, Modeling, Optimization techniques, and Power System