

Journal of Emerging Trends in Engineering and Applied Sciences (JETEAS) 1 (1): 72-78
© Scholarlink Research Institute Journals, 2010
jeteas.scholarlinkresearch.org

Triplen Harmonics Mitigation 3 Phase Four-Wire Electrical Distribution System Using Wye- Zig-Zag Transformers

Rosli Omar, Azhar Ahmad and Marizan Sulaiman

Faculty of Electrical Engineering, Universiti Teknikal Malaysia Melaka, (UTeM), 2004 Locked Bag,

Corresponding Author: Rosli Omar

Abstract

This paper studies an application of wye- zigzag transformes for reducing harmonics in the neutral conductors of a three phase 415/240V distribution system. Triplen harmonic currents add up in the neutral conductor of the distribution system feeding the non linear loads such as personal computers and electronic office machines with switch mode power supplies. The zigzag transformer is installed between the distribution panel and the high harmonics producing loads. This research makes use of a star-zigzag grounded transformer.

Keywords: zigzag transformer, triplen harmonics, mitigation, conductors, harmonics producing loads

INTRODUCTION

In recent years, concern over the quality of electric power has been increasing rapidly since poor electric power quality causes many problems for the affected loads, such as malfunctions, short life time and so on. Today load equipment is more sensitive to power quality variations than equipment applied to the past. Many new load devices contain microprocessor-based control and power electronic devices that are sensitive to many types of disturbances [Arrillaga, 1995].

Over the years many mitigation methods has evolved and used to address harmonics related problem; those widely used are K-rated distribution transformers, delta connected primary winding transformer, L-C tuned filters [L. Beverly 1993] and phase shifting transformer. But most of these solutions have its limitations. K-rated transformer does not reduce harmonics; it is design to tolerate higher harmonics current than the non K-rated transformer while maintaining its efficiency. Harmonics content in all conductors and neutral wire are still high and pose the same problem as before. K-rated transformer is also bigger in size and is more expensive. Delta connected primary winding transformer will force the triplen harmonics to circulate at its primary winding and eliminated balanced triplen harmonics. But this "circulating" act will generates heats in the transformer and reduces its efficiency. Furthermore, harmonics current in neutral wire is not eliminated. Shunt L-C tuned filters can cause undesirable system resonance that leads to catastrophic failure. Filters effectiveness will also change when loads changes (Chorea, 1990).

Phase-shifting transformer or better known as Zigzag transformer offers an attractive solution to harmonics

problem. The solution uses a number of small zigzag transformers to isolate and reduce harmonics current. This is attractive for the following reasons: low cost, easy to install, ability to reduce most harmonics current (on all conductors including neutral wire) thus eliminating the need for larger neutral wires (Gruzs, 1990)

Three phase four-wire power systems are used to supply power to computer systems, modern office equipment, other similar electronic loads in commercial building, the power system design should allow for the possibility of high harmonic neutral current to avoid potential problems. The main focus of this research try to investigate the effect of harmonic load current distortion. Zig-zag transformer on the load side of the effected neutral conductor. The contribution of this paper is the field application of low cost zigzag transformer to reduce triplen harmonics in all conductors.

Triplen Harmonic Current Problem In Three Phase Power System

On three phase power systems, neutral current is the vector sum of three line-to neutral currents. With balanced, three-phase, linear currents, which consist of sine waves spaced 120 electrical degrees apart, the sum at any instantin time is zero, and so there is no neutral current. In most three phase power systems supplying single-phase loads, there will be some phase current imbalance and some neutral current. Small neutral current resulting from slightly unbalanced loads do not cause problems for typical building power distribution systems. There are conditions where even perfectly balanced single-phase loads can result in significant neutral currents. Nonlinear loads, such as rectifiers and power supplies, have phase currents which aren't sinusoidal. The vector sum of balanced, nonsinusoidal, three phase

currents does not necessarily equal to zero (Gruzs, 1998, Koval, 1990,1997, Gruzs ,1990, Liew 1990).

In three-phase circuits, the triplen harmonic current (third, nine, fifteen, etc.) add instead of cancel. Being three time the fundamental power frequency and spaced in time by 120 electrical degrees based on the fundamental frequency, the triplen harmonic currents are in phase with each other, and add in the neutral circuit. High neutral currents in power systems can cause overloaded power feeders, overloaded transformers, voltage distortion and common mode noise (Pierce 1996, Robert 1994, Jih-Sheng Lai, 1997).

Harmonic Analysis by Mathematics

Harmonics are actually derived from mathematical model [IEEE Std 519-1992 1993], which is a technique to analyze currents and voltages. The distorted waveform from a perfect sinusoidal is generally expressed in terms of harmonic components in the frequency spectrum. This can be seen in fig. 1 below.

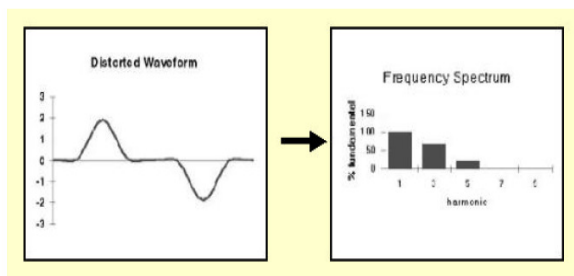

Figure. 1 Relationship of Distorted Waveform with Frequency Spectrum

The harmonic components drawn by the frequency spectrum can then be presented in a mathematical equation. With a power frequency (fundamental frequency)of 50Hz in Malaysia, the equation representing a harmonic frequency is given by

$$f_h = h \times 50 \text{ Hz}$$

Where;-

h is the harmonic order

In electrical power system,harmonic analysis not only deals with harmonic frequency but the process of deriving the magnitudes of voltages and currents must be included as well. Generally, another series of harmonic analysis in electrical power system using mathematical equation is known as Fourier analysis. Using the Fourier series, any voltage or current waveform may be reproduced from the fundamental frequency component together with the sum of the harmonic components.

$$V_t = a_0 + \sum V_h \sin(h \times 2\pi ft + \theta_h)$$

Where:-

a₀ is the dc component

V_h is the peak voltage level
 f is the fundamental frequency of 50Hz
 t is the time of one cycle
 θ_h is the phase angle

Another principle behind performing a harmonic analysis on a power system is to determine the Total Harmonic Distortion (THD).The term THD is a measure to identify the amount of harmonic distortion in a system voltage, usually expressed in percentages with respect to the fundamental voltage.

Zig-Zag Transformers

A basic three-phase Wye-zigzag transformer consists of a Wye-connected primary and a zigzag-connected secondary. The zigzag part is accomplished by winding half of the secondary turns of one phase of the transformer on one leg of the three-phase transformer, with the other half of the secondary turns on an adjacent phase [Square D, 2002]. The schematic diagram of the basic wye-zigzag transformer is shown in fig.2 below:

Figure.2: Wye-Zigzag Transformer connection

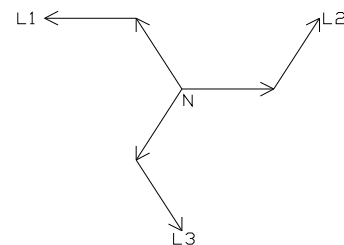
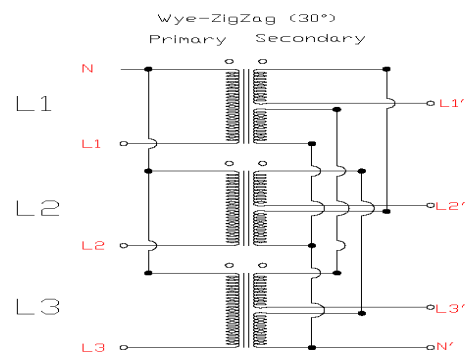

Figure.3: Wye-Zigzag Transformer Phasor Diagram

From the figure 2 we can see that L1 and L1' are wound on the same leg similarly L2 and L2' are so wound as well as L3 and L3' .

In operation, the harmonics current flow from the harmonics generating loads into the transformer secondary windings. With all triplen-harmonics current are in phase with each other, by vector analysis, the positive and negative flux interaction in the zigzag is “canceling” these triplen-harmonics. Hence there is reduced harmonics current flowing back into the primary and system.

Test of Harmonic Mitigation Devices

In order to develop an engineer solution to harmonic problems, it is usually necessary to measure the harmonics using a harmonics analyzer. These measurements will provide detailed information on the full spectrum of harmonic currents and voltages. It is best to start monitoring as close as possible to the sensitive equipment being affected by harmonic variation in the power system.

Laboratory tests has been carried out to represent a three-phase four-wire, 240/415V, electrical distribution system was connected to non-linear loads. Here, a 240/415V laboratory AC source was used as DP point, 3kVA wye-zigzag transformer was the mitigating device and 6 nos of. PC SMPS represent high harmonics generating loads. A line diagram of the proposed scheme as shown in fig. 4.

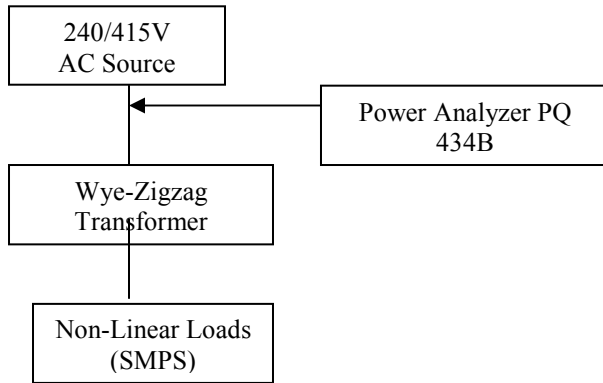

Figure.4 Proposed Scheme On Line Diagram

Measurements were taken for below instances:

- 1) Balanced and unbalanced loads connected directly to DPP
- 2) Balanced and unbalanced loads connected to wye-zigzag transformer

RESULTS AND DISCUSSION

Table 1a and table 1b show that the harmonics reading of the loads when connected directly to DP. As expected, these SMPS loads produce high harmonics content of 155% either in the balanced or unbalanced scenarios. The triplen-harmonics currents add up effect in neutral conductor can also be seen here, the neutral current reading is 1.73 times that of phase current. Under actual full load condition, this neutral conductor will suffer from overheating because of the extra current. For balanced load, the fundamental current, positive and negative sequence harmonics current (5th, 7th, 11th, 13th, 17th, 19th etc) will be cancelled out in the neutral conductor. But for an unbalanced load,, unbalanced residue currents will remain in the neutral conductor.

Table 1a: Harmonics reading for direct contact configuration (no transformer connection)

Current	Phase			
	L1	L2	L3	Neutral
THD ₁ (%)	155.1			18466.7
	158.9	159.3	146.4	
I _{Total}	1.950			2.031
	1.162	1.149	1.064	
I ^{1st}	0.619	0.611	0.600	0.011
I _{Harmonics}	0.983	0.973	0.879	2.031
3 rd	0.585	0.577	0.553	1.780
5 th	0.508	0.504	0.469	0.079
7 th	0.415	0.411	0.362	0.015
9 th	0.313	0.311	0.251	0.908
11 th	0.218	0.217	0.158	0.105
13 th	0.144	0.144	0.100	0.043
15 th	0.102	0.101	0.081	0.287
17 th	0.086	0.084	0.074	0.053
19 th	0.078	0.075	0.060	0.020
21 st	0.065	0.062	0.040	0.169

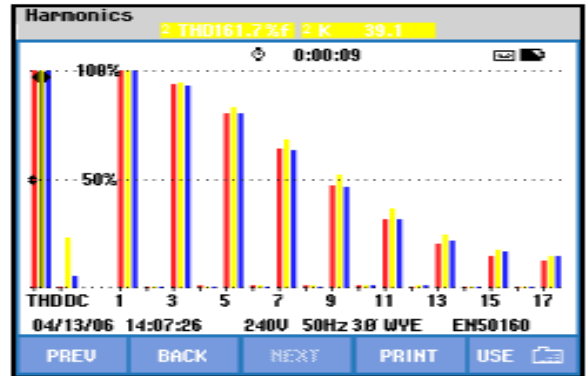

Fig 4: One line diagram indicating measurement point

Table 1b: Harmonics reading for direct contact configuration (no transformer connection)

Unbalanced Load

Current	Phase			
	L1	L2	L3	Neutral
THD _i (%)	155.5			386.5
	153.5	160.8	152.4	
I _{Total}	2.105			2.100
	1.678	1.149	0.541	
1 st	0.916	0.607	0.297	0.526
I _{Harmonics}	1.406	0.976	0.453	2.033
3 rd	0.858	0.573	0.275	1.699
5 th	0.737	0.503	0.237	0.461
7 th	0.589	0.413	0.188	0.314
9 th	0.432	0.315	0.137	0.877
11 th	0.289	0.223	0.093	0.214
13 th	0.185	0.151	0.063	0.080
15 th	0.133	0.107	0.049	0.280
17 th	0.114	0.088	0.043	0.102
19 th	0.099	0.077	0.036	0.030
21 st	0.075	0.064	0.027	0.158



Unbalanced Load

Fig.5b: Spectrum representation of harmonics for direct contact configuration (no transformer connection)

Table 2a and table 2b illustrate the effect of wye-zigzag transformer had on the electrical system. It can be seen from the table that wye-zigzag transformer installed between the load and DP has desirable effect in term of harmonic contents. It clearly shows “elimination” of balanced triplen-harmonics and the reduction of other harmonics. The phase THD_i is reduce, from 155% to 98% in the balanced loading and from 156% to 100% in the unbalanced loading. Total phase current is also reduced to 1.686A and 1.759A in balanced and unbalanced loading respectively. This translates to nearly 14% increase in system capacity.

Fig. 5a and Fig.5b below show that the spectrum representation of the harmonics current for balanced and unbalanced loads. Harmonics current dominates the overall current flowing in the conductors.

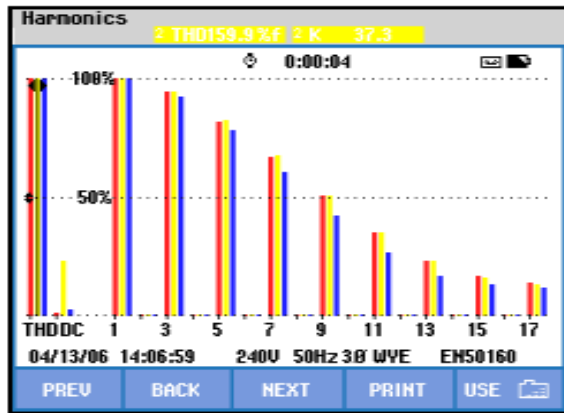

Fig.5a: Spectrum representation of harmonics for direct contact configuration (no transformer connection) **Balanced Load**

Table 2a: Harmonics Reading for loads connected to transformer (balanced)

Current	Phase			
	L1	L2	L3	Neutral
THD _i (%)	98.0			58.2
	89.2	109.2	98.0	
I _{Total}	1.686			0.234
	1.013	0.943	0.963	
1 st	0.756	0.637	0.688	0.202
I _{Harmonics}	0.675	0.695	0.674	0.118
3 rd	0.019	0.056	0.035	0.109

5 th	0.490	0.527	0.499	0.003
7 th	0.413	0.391	0.397	0.003
9 th	0.037	0.020	0.023	0.042
11 th	0.175	0.200	0.188	0.010
13 th	0.101	0.089	0.095	0.003
15 th	0.005	0.007	0.003	0.003
17 th	0.015	0.018	0.017	0.001
19 th	0.039	0.032	0.036	0.004
21 st	0.008	0.008	0.005	0.006

Table 2b: Harmonics Reading for loads connected to transformer (unbalanced)

Current	Phase			
	L1	L2	L3	Neutral
THD _i (%)	100.2			61.3
	93.8	102.5	101.4	
I _{Total}	1.759			0.229
	0.808	1.139	1.070	
1 st	0.589	0.795	0.751	0.195
I _{Harmonics}	0.553	0.815	0.762	0.120
3 rd	0.154	0.128	0.344	0.111
5 th	0.361	0.623	0.528	0.004
7 th	0.338	0.464	0.356	0.002
9 th	0.090	0.028	0.116	0.042
11 th	0.130	0.186	0.117	0.010
13 th	0.103	0.072	0.058	0.004
15 th	0.019	0.027	0.039	0.006
17 th	0.021	0.041	0.020	0.001
19 th	0.024	0.043	0.035	0.004
21 st	0.014	0.004	0.150	0.006

Neutral current has also reduced to 0.234A and .229A in the balanced and unbalanced loads. This significantly eliminates the danger of burnt neutral conductor.

Fig.6a and Fig.6b show a spectrum presentation of the harmonic current for balanced and unbalanced loads which were connected to the transformer. It can be seen graphically shows the “missing” triplen-harmonics.

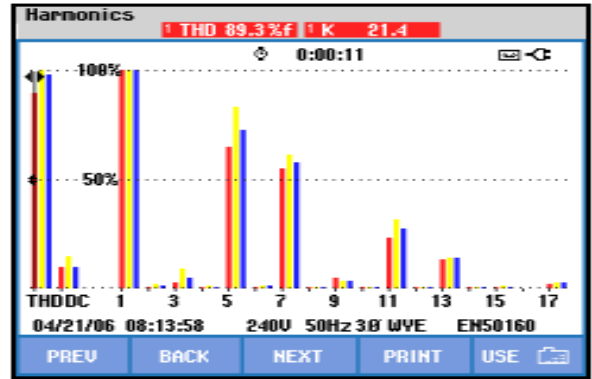

Balanced Load

Fig.6a Spectrum representation of the harmonics current for balanced load connected to the transformer.

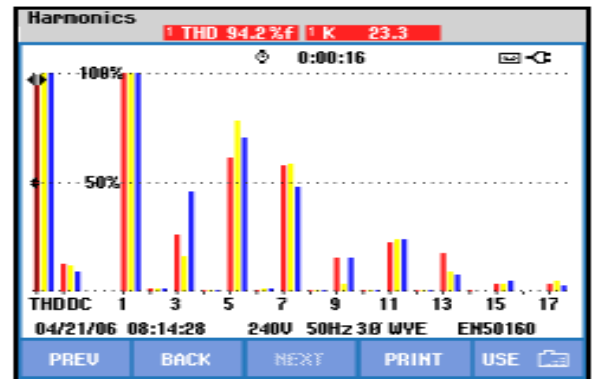

Unbalanced Load

Fig.6b Spectrum representation of the harmonics current for unbalanced load connected to the transformer.

"zig-zag" transformer can be used to replace the standard transformer in a system. This device has the special windings of the zig-zag built into the transformer secondary so that the triplen harmonic currents are cancelled in the secondary and do not circulate in the primary winding. Zig-zag transformer has a very low zero-sequence impedance, most of the zero-sequence current harmonics which are generated by the loads will circulate through the zig-zag transformer. This effect is even more significant for the zig-zag transformer with special windings for low zero sequence impedance. Notice that the higher the impedance, the lower the total current distortion.

When a zig-zag is connected between the phases and neutral of a wye system, the triplen harmonic currents are diverted through the device. These currents no longer flow, from the point where the zig-zag is connected in the system, upstream to the transformer, the phase wires carry only 50Hz current.

Table 3 shows that the reduction of the I_{Harmonics}, I_{Triplen} and I_{Neutral} currents with the application of the zig-zag

transformer .Note that it approaches (using zig-zag transformer) the waveshape of the fundamental current, thus showing that by reducing the harmonics, the system becomes more efficient.

Comparisons Of Harmonic Mitigation Techniques.

An increasing percentage of building load consists of electronic equipment supplied by switched-mode power supplies, electronic and magnetic ballasts, on line UPS systems, adjustable-speed drives, harmonic distortion problems in distribution system is becoming increasingly. Four-wire power systems are used to

supply power to computer systems, office equipment and other similar sensitive electronic loads,the power system design should allow for the possibility of high harmonic neutral current to avoid potential problems.

There are too many harmonic mitigation techniques been used in order to avoid harmonics problem in distribution system . Table 4 provides an example comparison of harmonic mitigation techniques (Jih-Sheng, et, al.).

Table3: Comparison of Laboratory Results

	Without Zig-zag Transformer (Balanced Load)	With Zig-zag Transformer (Balanced Load)	Without Zig-zag Transformer (UnBalanced Load)	With Zig-zag Transformer (UnBalanced Load)
$I_{\text{Harmonics}}$	1.639 A	1.180 A	1.770 A	1.245 A
I_{Triplen}	1.129 A	0.085 A	1.219 A	0.454 A
I_{Neutral}	2.031 A	0.234 A	2.100 A	0.229 A

Table 4: Comparison of Harmonic Mitigation techniques

	Drive Harmonic Mitigation Technique	Comments
1	6 Pulse AC Drive without a DC Link Choke	The simplest of the AC drive. Doesn't provide any harmonic mitigation capability
2	6 Pulse AC Drive with a DC Link Choke	The choke provides reduction of low frequency harmonics produced by the drive.
3	Input Line Reactor	Reduces surges or spikes on the line. Provides enough harmonic mitigation on distribution systems that have a very small percentage of non-linear loading
4	Tuned and Non-tuned harmonic Filters	Cost and performance effective but can cause power system resonance in some installations, especially if there are any future system impedance changes.
5	18 Pulse Converter with Isolation Transformer	Reasonable performance and cost effective, but does not guarantee meeting IEEE19-1992 without analysis. Less component count and design complexity compared to an 18 pulse. An auto transformer will have a lower cost and smaller physical size.
6.	Regeneration Active Front End	Has the added feature of regenerative braking back to line. Generally only cost effective on large common bus systems with many drives of high horse power ratings.
7.	Active Power Filter	Most technologically advanced solution but generally only cost effective on large common bus systems.
8.	Wye-Zig-zag Transformers	Low Cost. Significantly reduced neutral current flowing back to the system.

As shown in table 4 we found that harmonic mitigation techniques using wye-zig-zag transformers are a viable choice for mitigating rich triplen harmonics in four-wire electrical distribution system. As comparison made in term of costs, wye-zig transformers show that low cost as to compare with active filter and other types of harmonic mitigation. The proposed approach is much simpler, cheaper and reliable compared to approaches using active filters. The costs comparison with active filter as shown below:

Active Filter – RM1750/kVA
Transformer – RM 300/kVA

Wye-Zigzag Transformers are also significantly reduced neutral current flowing back to the system almost up to 90%.

CONCLUSION

Mitigation of triplen harmonic in distribution system using zig-zag transformers is more effective for reducing harmonics in the neutral conductors of a three phase 415/240V. Measurements of current draw before and after the installation of a zig-zag transformer are presented. Experimental results show that the proposed approach can reduce significantly reduced this can be seen from the laboratory test results which showed that low cost wye-zigzag transformer could be a viable choice to mitigate harmonics rich electrical distribution system. Installing many small wye-zigzag transformers at the DP will improve overall system performance and reduce risk associated with harmonics.

The proposed approach is much simpler, cheaper and reliable compared to approaches using other mitigation techniques.

ACKNOWLEDGEMENT

The authors wish to thank UTeM for providing short term grant for this project.

REFERENCES

Arrillaga 1995, Power System Harmonics, John Wiley and Sons

L. Beverly, R. Hance, A. Kristalinski and A. Visser 1993, Comments about the use of a zig-zag transformer to reduce the neutral current created by unbalanced non-linear, Fermi National Accelerator Laboratory, Batavia Illinois, September

“A clear perspective on Harmonic Mitigating Transformers” 2002 Square D, Bulletin No. 7400DB0201
T. M. Gruzs 1990, A Survey of neutral currents in three-phase computer power system.

P.P. Chorea 1990, Application of zig-zag transformer for reducing harmonics in the neutral conductor of low voltage distribution system, IEEE Ind. Appl. Soc. Ann. Meet..

IEEE Std 519-1992 1993, “IEEE Recommended Practices and Requirements for Harmonics Control in Electrical Power Systems”, IEEE, New York..

T.M. Gruzs 1998, " Power system Problems from High Harmonic Neutral Currents," Compute. Technology Rev., Winter.

D. O. Koval 1997, "Power Quality Characteristics of Computer Loads, " IEEE Trans. Ind. Applicat., Vol. 29, No. 6.

D.O. Koval 1990, " Distribution Customers Power Quality Experience,"IEEE Trans. Ind. Applicat., Vol. 29, No.4.

T.M. Gruzs 1990, " A survey of Neutral Currents in Three-phase Computer Power System," IEEE Trans. Ind. Applicat., Vol. 26, No.4.

A. Liew 1990, "Excessive Neutral Currents in Three Phase Fluorescent Light Circuits,"IEEE Trans. Ind. Appl., Vol.25, No.4.

L.W. Pierce 1996, "Transformer Design and Application Considerations for Nonsinusoidal load Currents," IEEE Trans. Ind. Applicat., Vol.32, No.3.

D.H. Robert, J.R. Patrick 1994, "Harmonics: Effect on Power Quality and Transformer," IEEE Trans. Ind. Applicat., Vol. 30.

Jih-Sheng Lai 1993, T.J. Key, " Effectiveness of Harmonics Mitigation Equipment for commercial Office Building,"IEEE Trans. Ind. Applicat., Vol. 32.