

Water Quality Monitoring System Using Zigbee Based Wireless Sensor Network

Zulhani Rasin

Faculty of Electrical Engineering Universiti
Teknikal Malaysia Melaka (UTeM)
Melaka, Malaysia
Email: zulhani@utem.edu.my

Mohd Rizal Abdullah

Faculty of Electrical Engineering
Universiti Teknikal Malaysia Melaka (UTeM)
Melaka, Malaysia
Email: rizal_dem@yahoo.com

Abstract— The application of wireless sensor network (WSN) for a water quality monitoring is composed of a number of sensor nodes with a networking capability that can be deployed for an ad hoc or continuous monitoring purpose. The parameters involved in the water quality determination such as the pH level, turbidity and temperature is measured in the real time by the sensors that send the data to the base station or control/monitoring room. This paper proposes how such monitoring system can be setup emphasizing on the aspects of low cost, easy ad hoc installation and easy handling and maintenance. The use of wireless system for monitoring purpose will not only reduce the overall monitoring system cost in term of facilities setup and labor cost, but will also provide flexibility in term of distance or location. In this paper, the fundamental design and implementation of WSN featuring a high power transmission Zigbee based technology together with the IEEE 802.15.4 compatible transceiver is proposed. The developed platform is cost-effective and allows easy customization. Several preliminary results of measurement to evaluate the reliability and effectiveness of the system are also presented.

Keywords— wireless sensor network, water quality monitoring, Zigbee technology

I. INTRODUCTION

This work started after considering the critical situation of the polluted natural water resources in Malaysia. Keeping our water resources so that it is always within a standard determined for domestic usage is a crucial task. As the country is making its progress through industrialization, our water resources are prone to a threat of pollution especially from the industrial activities. It is a challenge in the enforcement aspect as it is impossible for the authorities to continuously monitor the location of water resources due to limitation especially in man power, facilities and cost of equipment. This often lead to a too late to be handled situation.

For that, it is important to have such a monitoring system with characteristics of autonomous, lower cost, reliable and flexible. The use of automation in monitoring task will reduce the reliance on man power at the monitoring site thus reducing the cost.

This project focuses on the use of multiple sensors as a device to check the level of water quality as an alternative method of monitoring the condition of the water resources. Several sensors that are able to continuously read some parameters that indicate the

water quality level such as chemical substances, conductivity, dissolved oxygen, pH, turbidity etc will be used to monitor the overall quality level. As the monitoring is intended to be carried out in a remote area with limited access, signal or data from the sensor unit will then be transmitted wirelessly to the base monitoring station.

A currently becoming popular and widely used technology based on wireless sensor network is extensively used in this project as it is able to provide flexibility, low cost implementation and reliability. A high power transmission with a relatively low power consumption Zigbee based wireless sensor network technology is applied in this work. Zigbee is a communication standard for use in the wireless sensor network defined by the Zigbee Alliance [1] that adopting the IEEE 802.15.4 standard for its reliable communication. It is chosen due to its features that fulfill the requirement for a low cost, easy to use, minimal power consumption and reliable data communication between sensor nodes.

The development of graphical user interface (GUI) for the monitoring purposes at the base monitoring station is another main component in the project. The GUI should be able to display the parameters being monitored continuously in real time. Several measurement and performance analysis to evaluate the reliability, feasibility and effectiveness of the proposed monitoring system are also presented.

II. RELATED WORKS

There are many works on the application of WSN for monitoring system such as in [2], where Zigbee is used to monitor the condition of long span bridge after considering disadvantages of the currently used wire and cable for data communications such as high installation cost of communication and power supply for the sensors, difficulty in the installation of steel pipeline for protecting the cables, sensor data distortions due to temperature changes on cables, noise affecting cables and sensors etc. The Zigbee is used for the short distance communication while CDMA (Code Division Multiple Access) infrastructure was used for long distance communication between sensors and the server system. Another application of Zigbee in monitoring system is found in [3] for parking management system. In this work the Zigbee module is based on the ATmega128L

microprocessor combined with the Chipcon CC2420 transceiver IC. In [4], an electrocardiogram (ECG) signal monitoring system based on Zigbee is presented. This system is proposed to be used in telemedicine service where there are no direct contact between the patient and the physician and becomes a fundamental for the development of efficient remote monitoring systems, providing continuous, real-time and accurate information about health conditions of the patient. Coverage performance measurement result in the indoor environment shows the system able to cover two or three rooms depending on the wall thickness and the relative position of transmitter and receiver as shown.

From all the previous related works described, it can be concluded that there are limitless possibilities of Zigbee in wireless sensor network application. Solution providers of Zigbee offer various kind of platform in the market based on user requirement. For this paper, the difference is the use of high transmission power with low power consumption Zigbee platform.

III. HARDWARE DESIGN

A. Sensor Unit

A sensor unit is basically consists of several sensors used to detect the predetermined parameters that indicate the quality of water. In this work, three types of sensor; pH sensor that senses the acidity of basicity of the water, temperature sensor and turbidity sensor based on phototransistor are used. All the sensors use battery for its operation. The information being sensed by the sensors are then converted into electrical signal and go through the signal conditioning circuit that functions to make sure the voltage or current produced by the sensors is proportional to the actual values of parameters being sensed. Then it is passed to a microcontroller or microprocessor that processes it to the value understandable by human.

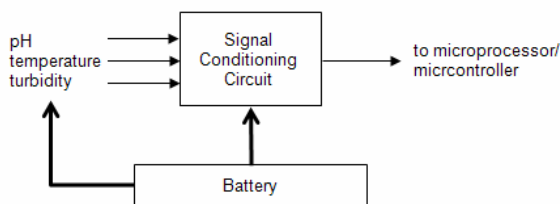

Fig.1 Block diagram of sensor unit

B. Wireless Sensor Node

The wireless sensor node in this work is consist of sensor unit as mentioned in section A; a microcontroller or microprocessor with a task of signal digitizing, data transmission, networking management etc; and radio frequency transceiver for communications at the physical layer. All of them share a single battery as a power source. The following Fig. 2 shows the block diagram of the wireless sensor node.

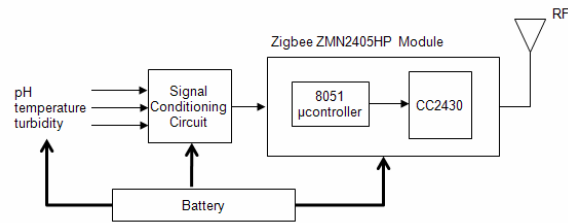

Fig. 2 Block diagram of Zigbee based wireless sensor node

The main microprocessor of the sensor node is based on the Zigbee compliance product from Cirronet. The high power transmission type ZMN2405HP Zigbee module is using the CC2430 transceiver IC from Texas Instrument comply to the IEEE 802.15.4 standards with a maximum transmission power of 100 mW using the dipole antenna and 250 mW using the directional patch antenna. The transceiver IC is integrated with the 8051 microcontroller with a low power but high performance of 64 kByte programmable flash features. The module alone requires a 5VDC power supply, multiple sensor inputs/outputs with ADC, operating at a frequency of 2.4 GHz with a configurable sleep mode to get the best of power consumption as low as 3uA [5].

The main microcontroller in the module is reprogrammable whether to function as an end device, router or coordinator nodes. As an end device sensor node, it can only communicate with the router or coordinator to pass the data from the sensor. An end device can only communicate indirectly with the other end device through the router or coordinator. The sensor node defined as a router is responsible for routing data from other routers or end device to the coordinator or to other routers closer to the coordinator. The router can also be a data input device like the end device but in actual application it is generally used to extended the coverage distance of the monitoring system. There can be only one coordinator for the monitoring system. The coordinator responsible for setting the channel for the network to use, assigning network address to routers and end devices and keeping the routing tables for the network that are necessary to route data from one end device to another in the same Zigbee network.

For the actual implementation, a 9V battery supply is used and directly connected to a 5V voltage regulator before goes to the Zigbee module.

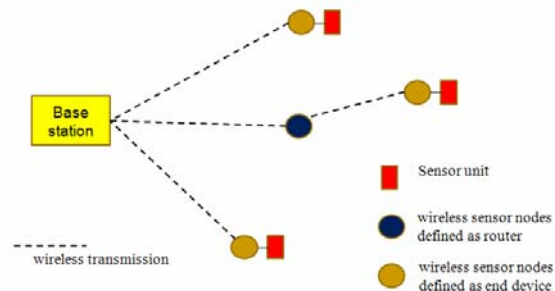

Fig.3 Block diagram Zigbee based wireless sensor network for the monitoring system

C. Base Monitoring Station

The base station consists of a same Zigbee module programmed as a coordinator that receives the data sent from the sensor nodes (end devices and routers) wirelessly. As the coordinator needs to continuously receiving data from the end devices, it is normally mains powered. Data received from the end device nodes is sent to the computer using the RS 232 protocol and data received is displayed using the built GUI on the base monitoring station.

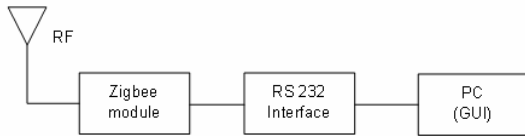

Fig. 4 Block diagram of components in base station

IV. SOFTWARE DESIGN

The GUI platform was successfully developed using Borland C++ Builder programming that able to interact with the hardware (coordinator) at the base station.

As shown in Fig. 5, three end devices are set for connection to the coordinator with one of them linked through the router to further extend the monitoring distance. Firstly, the user has to create a connection from the coordinator to the display unit, discover the surrounding nodes and setting the data polling rate using the buttons provided on the left side of the screen. The links coloured in red means that the connection is not yet established. When connections are establish the links change its colour to green as in the following Fig. 6. This is made so that it is easy for the user to identify the connection status of sensor nodes in the network based on the links status.

To know the values of parameters being sensed, the user is able to directly zoom to each sensor nodes and all the values will be displayed as shown in Fig. 7 by clicking on the desired node. Here the actual values of temperature, pH and water turbidity are displayed in real time. As in Fig. 8, the user can get a one shot display of measurement status at every sensor node by clicking on the coordinator icon. Shown together are the Link Quality Indicator (LQI) values for every connection between sensor nodes and the coordinator. The details about LQI are explained in section V.

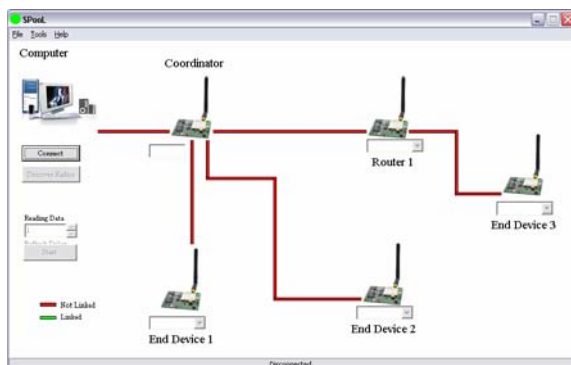

Fig. 5 Initial status of the GUI main page

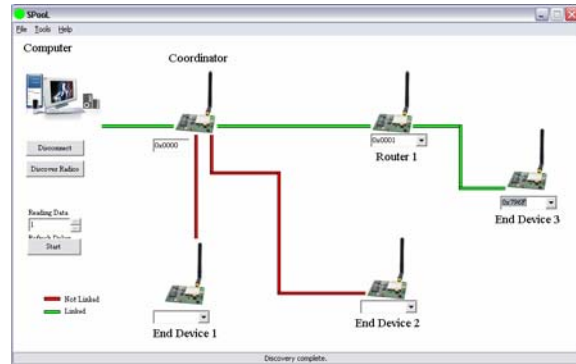

Fig. 6 Status of the GUI main page when network and connections between sensor nodes are established

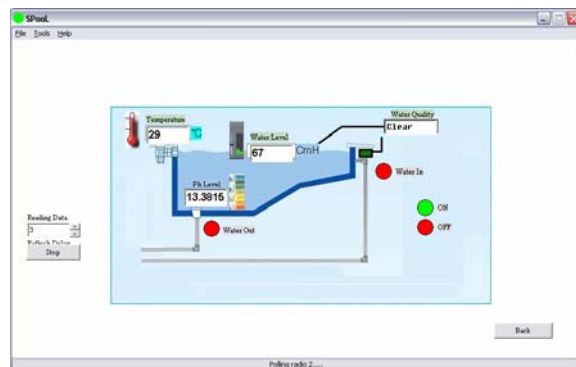

Fig. 7 Zoom display of values of parameters being sensed at any sensor nodes



Fig. 8 One shot display of measurement status at every sensor node

V. MEASUREMENT

Several preliminary measurements are carried out to evaluate the performance and effectiveness of the Zigbee based WSN on the irrigation control system to confirm the reliability and feasibility of using it for the actual monitoring purpose.

A. Power Consumption

Low power consumption is an important criterion in the WSN deployment to make sure it is able to operate in long time with minimum maintenance. The power

consumption measurement is only carried for the end device as the coordinator is practically mains powered at the base station.

During the measurement, the end device is configured to be in a timer sleep mode condition. The node is configured to wake up at every 30 minutes interval for 100ms just to send the data to the base station. For the rest of the time, the end device is in a sleep condition.

B. Coverage Performance

Coverage is another important aspect of WSN as it shows how large area of monitoring can be covered and to guarantee the delivery of data from the sensor nodes to the base station at reliable signal strength.

Measurement is carried out in a flat outdoor open field with no obstacles assumed close to actual application. Base station is located at the centre of the area and sensor nodes is placed at certain interval of distance at different angle covering 0° to 360°. The coverage performance measurement is based on the average value of LQI produced by the sink node when receiving data for 20 cycles. All the sensor nodes and coordinator at the base station is using a 2 dB gain omnidirectional dipole antenna with transmitted power of 100 mW. The details on LQI are explained in the next section C.

C. Link Quality Indicator (LQI)

The CC2430 transceiver IC used in the module has a built-in Received Signal Strength Indicator (RSSI) which is based on the receiver Energy Detection (ED) measurement used by a network layer as part of channel selection algorithm. During the ED measurement, the received signal power averaged for eight symbol periods within the bandwidth of an 802.15.4 channel is estimated. The value of ED is an 8 bit integer ranging from 0x00 to 0xff with minimum value of 0 indicates received power less than 10 dB above the specified receiver sensitivity and ranges at least 40 dB to the maximum value. The mapping from the received power in decibels to ED value supposed to be linear with an accuracy of ± 6 dB [6].

The LQI value is an unsigned 8-bit integer ranging from 0 to 255 with the maximum value representing the best possible link quality. The LQI value in CC2430 is calculated based on the RSSI value produced during the ED measurement and the average correlation value for each incoming packet, based on the eight first symbols following the packet SFD (Start of Frame Delimiter) [7].

LQI is chosen an indicator of coverage performance compared to RSSI because it does take into account the effect of noise during the data transmission and not solely on the signal strength produced by the module.

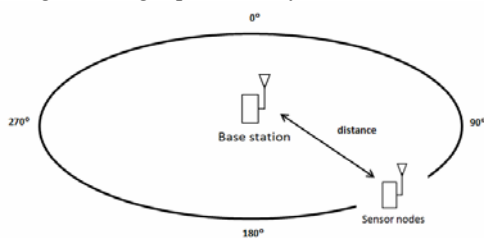

Fig. 9 Coverage performance measurement method

VI. RESULT AND DISCUSSION

A. Power Consumption

The following Table I shows the average power consumption for the end device, measured for both during active and sleep mode condition.

TABLE I
END DEVICE POWER CONSUMPTION

State	Voltage (V)	Current (mA)
Active	9.0	35.5
Sleep	9.0	28.8

It is important to be mentioned here that the above measured average power consumption is not considering the power consumed by the module only, but also includes the voltage regulation component and its peripheral circuits consists of basic components such as resistor and capacitor as well as power supply for the sensors used.

Based on the above result, the lifetime of the battery can be calculated as follow.

$$\begin{aligned} \text{Power consumption during active mode :} \\ &= 35.5 \text{ mA} \times 100\text{ms} / (60 \times 60 \times 1000) \\ &= 0.00099 \text{ mAH} \end{aligned}$$

$$\begin{aligned} \text{Power consumption during sleep mode :} \\ &= 28.8 \text{ mA} \times 30 \text{ minutes} / 60 \\ &= 14.4 \text{ mAH} \end{aligned}$$

$$\text{Total power consumption} = 14.4 + 0.00099 \approx 14.4 \text{ mAH}$$

$$\text{Battery capacity} = 170 \text{ mAH}$$

$$\text{Expected battery lifetime} = 170 / 14.4 = 11.81 \text{ hours}$$

From the measurement result, the end device nodes are able to operate for a continuous 12 hours without the need of installing a new battery using a rechargeable battery with capacity of 170 mAH. It means that it can be used in an ad hoc style for short period of time and of course a better time is expected if a larger capacity battery is used. Furthermore, the result can be better improved if circuitry for the module power supply is carefully considered to use a component with very low power consumption plus a smart power management that can reduce the voltage supply necessary for the module during the sleep mode. Choosing the right power output based on the area to be covered and customizing the firmware carrying out the tasks in the Zigbee module can also significantly reducing the overall power consumption.

B. Coverage Performance

The following Fig.10 shows the coverage performance based on the LQI value. Between 10 to 50m distance from the base station, an average uniform signal strength is obtained comply with the use of omnidirectional

antenna. In order to further evaluate the maximum distance that can be reached, one direction is chosen and the distance of end device from the base station is extended. As shown in Fig. 11, reliable signal strength can still be obtained at 100% success of packet delivery up to the distance of 210 m. The decrease of the LQI value with the distance extension is expected. Unfortunately the maximum reachable distance cannot be determined as the distance can not be further extended due to the geographical constraint. The use of router between the end device nodes and the coordinator is expected to further increase the coverage distance.

On the coverage performance, with the use of high power transmission, minimal number of sensor nodes for maximum area coverage can be expected. However, other measurement at several more different environments is necessary to obtain a more reliable data that also considering the worst case scenario.

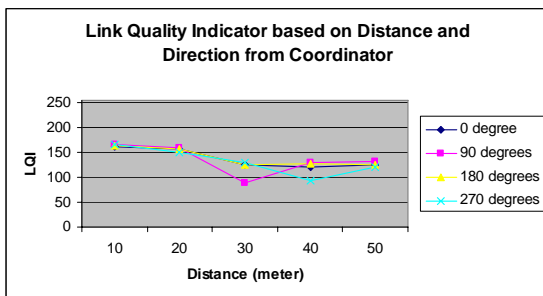

Fig. 10 Value of LQI based on distance and direction from coordinator module for distance of 10 ~ 50 meters

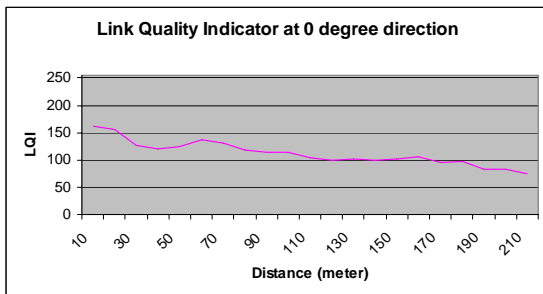

Fig. 11 Value of LQI for extended distance up to 210 meters

VII. CONCLUSION

Overall, the proposed implementation of high power Zigbee based WSN for water quality monitoring system offering low power consumption with high reliability is presented. The use of high power WSN is suitable for activities in industries involving large area monitoring such as manufacturing, constructing, mining etc. Another important fact of this system is the easy installation of the system where the base station can be placed at the local residence close to the target area and the monitoring task can be done by any person with minimal training at the beginning of the system installation. Performance modelling in different environment is one important

aspect to be studied in the future as different kind of monitoring application requires different configuration during system installation.

REFERENCES

- [1] (2009) The Zigbee Alliance website. [Online]. Available: <http://www.zigbee.org/>
- [2] Chae, M.J., Yoo, H.S., Kim, J.R., and Cho, M.Y., "Bridge Condition Monitoring System Using Wireless Network (CDMA and Zigbee)," *23rd International Symposium on Automation and Robotics in Construction ISARC 2006*, Tokyo, Japan, 3 – 5 Oct 2006.
- [3] Sangmi Shim, Seungwoo Park and Seunghong Hong, "Parking Management System Using Zigbee," *IJCSNS International Journal of Computer Science and Network Security*, Vol. 6 No. 9B, September 2006.
- [4] F. Vergari, V. Auteri, C. Corsi and C. Lamberti, (2009, October 31), "A Zigbee-based ECG Transmission For Low Cost Solution In Home Care Services Delivery," *Mediterranean Journal of Pacing and Electrophysiology – Special Issue Article Preview*, [Online], Available : <http://www.mespe.net/en/newselem/>
- [5] Cirronet, *ZMN2405/HP Zigbee™ Module Developer's Kit User Manual*, Rev A 2007.
- [6] IEEE *Wireless Medium Access Control (MAC) and Physical Layer (PHY) Specifications for Low Rate Wireless Personal Area Network (LR-WPANs)*, IEEE Standard 802.15.4™, 2003.
- [7] *CC2430 PRELIMINARY Data Sheet* (rev. 1.03), Chipcon Products from Texas Instruments, AS, 2006.