

## ORIGINAL ARTICLES

### The Study Of Wear Process On Uncoated Carbide Cutting Tool In Machining Titanium Alloy

<sup>1</sup>M.A. Sulaiman, <sup>2</sup>C.H. Che Haron, <sup>2</sup>J.A. Ghani, <sup>1</sup>M.S. Kasim

<sup>1</sup> Department of Process, Faculty of Manufacturing Engineering, Universiti Teknikal Malaysia Melaka, 76100 Melaka, Malaysia

<sup>2</sup>Department of Mechanical and Material Engineering, Faculty of Engineering, Universiti Kebangsaan Malaysia, 43600 Bangi, Selangor, Malaysia

---

#### ABSTRACT

The uncoated carbide cutting tools were used in turning titanium alloy Ti6Al4V bar with hardness of 340 HV. The main objective to find the wear behaviour of the cutting tool based on the flank wear data. The experiments were performed under dry cutting condition at various combinations of cutting speed and feed rate. The cutting speeds selected in the experiment were 15, 25, 35 and 45 m/min. Meanwhile the feed rates were used at 0.02 and 0.04 mm/rev. In this research depth of cut, doc was kept constant at 0.5 mm for all combinations of cutting parameters. Tool wear was measured under optical microscope and the data of flank wear which was gained through the experiment has been analysed. According to these graph shown that the affected of cutting parameters onto tool wear. The experiment's result showed that the flank wear increased with the cutting speed and feed rate. The flank wear occurs gradually at beginning of machining and at the end of failure when  $V_{b_{avg}}$  reached 0.3 mm where flank wear occurs.

**Key words:** Uncoated carbide, Titanium alloy, Flank wear, dry cutting.

---

#### Introduction

Coated and uncoated carbides are widely used in the metal working industry especially in turning operations. When machining using carbides under typical cutting conditions, the gradual wear of the flank is one of the main processes where a cutting tool fails. According to (V.C. Venkatesh 1980), carried out tool wear investigation on some cutting tool materials. He plotted tool life curves using the flank wear criterion and obtained that the tool life of carbides decreased quickly at higher speed.

The use of coolant to increase tool life and better surface machined quality is an issue with many different perceptions (M.A. Sulaiman *et al.* 2010). In contrast, others have found that coolant promote tool wear in machining. The inherent brittleness of carbides renders them susceptible to severe damage by cracking if sudden loads are applied to their edge. Besides (W. Konig and R.L. Klinger., 1990) also claimed that better performance of carbides was obtained under dry cutting. The dry machining method or green machining was selected in order to avoided from using degradable coolants, which are harmful for human, degrade the environment and increase cost operation (Ibrahim, G.A. *et al.* 2007).

This paper is a contribution towards understanding the behaviour of carbides, mainly the aim of describing the wear behaviour of uncoated carbide tools based on the flank wear data. The 80° diamond shape insert uncoated carbide tool was used in turning titanium alloy Ti6Al4V. Meanwhile the experiment was performed under dry cutting condition at various cutting speeds (15, 25, 35 and 45 m/min). The feed rates were used at 0.02 and 0.04 mm/rev, meanwhile depth of cut was kept constant at 0.5 mm.

Normally during machining with the titanium alloy, it has a tendency to weld to the tool due to chemical reactive characteristic, thus lead to chipping and premature tool failure especially with the coated cutting tool. Additionally the titanium alloy is low thermal conductivity thus increase the heat at the tool-workpiece interface. However titanium has high strength at elevated temperatures and low modulus of elasticity.

#### Materials And Methods

##### Workpiece material:

In this study, the titanium alloy Ti6Al4V was selected as the workpiece material. The material was supplied in fully annealed condition, cylindrical in shape, 100 mm diameter and 150 mm length. The workpiece was

---

**Corresponding Author:** Mohd Amri Sulaiman, Department of Process, Faculty of Manufacturing Engineering, Universiti Teknikal Malaysia Melaka, Hang Tuah Jaya, 76100 Durian Tunggal, Melaka Malaysia. Tel: +60196141887; E-mail: mohdamris@yahoo.com

checked for its hardness across the diameter at each end prior to the test and the average value of hardness was 340 HV. The chemical compositions of workpiece material are given in Table 1.

**Table 1:** Chemical compositions of titanium alloy Ti6Al4V (% wt)

O	N	C	Fe	Al	V	Ti
0.18	0.015	0.04	0.13	6	4	Bal.

*Cutting tools and tool geometry:*

Wear resistance and chemical stability are the most important properties for a tool material intended for turning titanium alloy. The workpiece surface has an abrasive effect on the tool material, and the high temperature on the cutting edge causes diffusion between tool and chip. Moreover, if the surface has any kind of interruption, toughness is an additional necessary property of the tool material, in order to prolong tool life [7].

Uncoated carbide insert was used for the turning operations. The carbide inserts CNMG 120408-M5 TP1000 were supplied by SECO Tools where main composition is tungsten carbide 94% WC and cobalt 6% Co as binder. The dimensions of cutting tool are given in Table 2.

**Table 2:** Dimension of cutting tool

Parameter	Dimension (mm)
I.C.	12.7
T	4.76
R	0.79
D	5.16

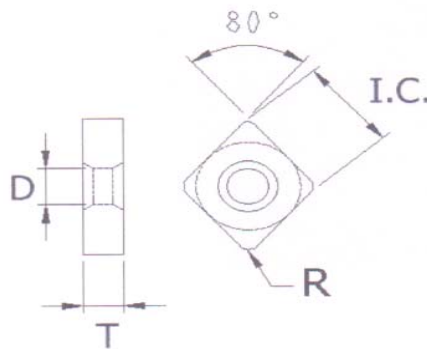

**Fig. 1:** Cutting tool diagram

*Cutting condition:*

In this study, there were eight combinations cutting parameters had done in turning operation. There were four cutting speeds 15, 25, 35, and 45 m/min with two feed rates at 0.02 and 0.04 mm/rev. Meanwhile the depth of cut kept constant at 0.5 mm for all combinations and those experiments were done under dry cutting condition. The combinations of cutting parameters are shown in Table 3.

**Table 3:** The combinations of cutting parameters

SET	Cutting speed, m/min	Feed rate, mm/rev	Depth of cut, mm
1	15	0.02	0.5
2	25	0.02	
3	35	0.02	
4	45	0.02	
5	15	0.04	
6	25	0.04	
7	35	0.04	
8	45	0.04	

*Experimental technique:*

The set of tool and workpiece were mounted on a Colchester T4 6000 CNC lathe machine with a GE Fanuc Series 21i-TB as the controller. The machine was operated at the specified cutting condition described previously. Meanwhile tool wear was observed and measured by using Perthometer 3D optical microscope, with a magnification ranging from 5 to 10 times.

Flank wear was observed and measured at various cutting intervals throughout the experiment. In order to avoid concentrated impact load that could trigger chipping when machining started, a 2 mm precut entry was made for every new pass of cutting [3]. A separate cutting tool was used to machine this precut entry for each test using the same cutting condition setting.

After precut was done, a tested insert was used according to the combination in Table 3. Cutting operation was stopped at subsequent 5 mm length, and cutting time was taken. While insert was dismantled from tool holder and tool wear was measured. The experiment for particular insert finished when the average flank wear,  $VB_{avg}$  reached 0.3 mm. These steps were repeated for all combinations.

According to ISO 3685:1993 has suggested a standard for tool life testing [4]. The criteria listed were used as a basis for rejecting a tool: (i) when the average flank wear reached 0.3 mm or the maximum flank wear reached 0.6 mm; (ii) when the notch at the depth of cut reached 1.00 mm; (iii) when the crater wear depth reached 0.14 mm; (iv) when the surface finish on the work material exceeded 6 mm centre line average and (v) when flaking or fracture occurred. Cutting was stopped when any of the above occurred. Cutting was abandoned and the tools were discarded as and when catastrophic fracture of the edge was observed.

## Results And Discussions

### Tool wear:

The cutting edge of an insert is subjected to a combination of high stresses, high temperatures, and perhaps chemical reactions which cause the tool wear due to one or several mechanisms. These mechanisms depend on the tool and workpiece material combination, cutting geometry, the environment, and mechanical and thermal loadings encountered [8, 9]. The experiment result for all combinations of cutting parameters and measured flank wear are shown in Table 4.

**Table 4:** Result of cutting time and flank wear for all combinations

Set	Cutting speed, m/min	Feed rate, mm/rev	Depth of cut, mm	Cutting time, s	Flank wear, mm
1	15	0.02	0.5	257.97	0.31
2	25	0.02	0.5	124.98	0.33
3	35	0.02	0.5	61.64	0.33
4	45	0.02	0.5	49.10	0.35
5	15	0.04	0.5	121.59	0.34
6	25	0.04	0.5	87.20	0.32
7	35	0.04	0.5	47.42	0.32
8	45	0.04	0.5	29.57	0.33

According to the Table 4, the combination of set 1 gave the longest cutting time (about 260s or 4.3 min). Meanwhile the maximum speed and feed rate on set 8, gave the shortest cutting time (approximate 30s or 0.5 min) for the uncoated carbide insert in this study. Here cutting time was also referred as tool life.

Figure 2 and 3 shows the progression of the typical average flank wear at the speeds of 15, 25, 35 and 45 m/min when machining titanium alloy Ti6Al4V with inserts CNMG 120408-M5 TP1000 at feed rates 0.02 and 0.04 mm/rev respectively. From the figures, it can be seen that the flank wear curves were generally in three stages; at initial stage, followed by gradual stage and finally the abrupt stage of wear. This behaviour was also reported by previous researched (J.P. Chubb, J. Billingham, 1980, 6].

The flank wear rate was rapid at higher cutting speeds and feed rates, additionally cutting under dry conditions. Increased flank wear rate was observed with increase in the cutting speed. A shorter contact area at the chip-tool interface was observed at high cutting speeds. This caused a concentration of high temperature very close to the cutting edge. It has been shown in Figure 2 and 3 where cutting speed at 45 m/min produced the highest value of  $VB_{avg}$  for flank wear. On the other hand, increased the feed rate contributes to shortened the cutting time or tool life and this had shown on Figure 4 and 5. This significant decrease in the tool life for inserts at higher feed rate can be attributed to the increase of temperature and plastic deformation. These factors weaken the cutting tool material.

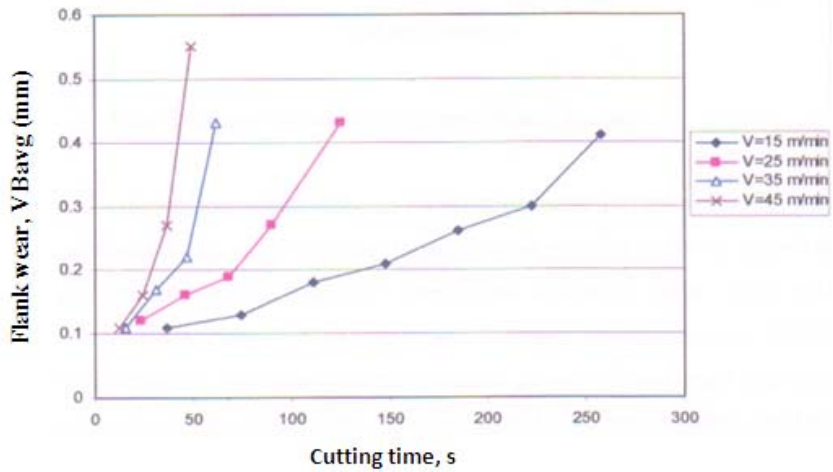

Fig. 2: Flank wear on various cutting speed when feed rate = 0.02 mm/rev

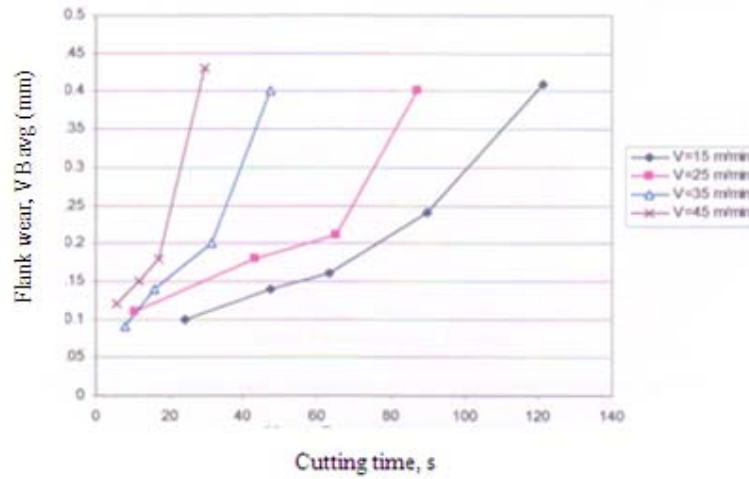

Fig. 3: Flank wear on various cutting speed when feed rate = 0.04 mm/rev

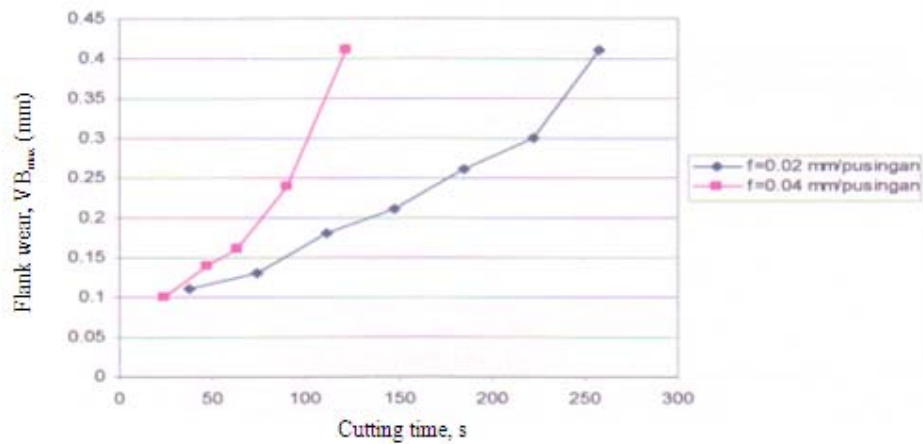
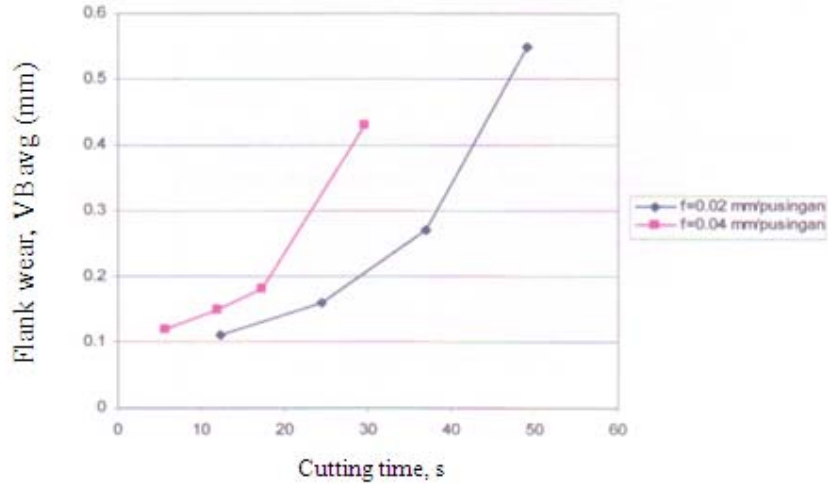

Fig. 4: Flank wear on different feed rate when cutting speed = 15 m/min



**Fig. 5:** Flank wear on different feed rate when cutting speed = 45 m/min



**Fig. 6:** Tool wear at early cutting (a) and final cutting (b) when  $V = 15$  m/min and  $f = 0.02$  mm/rev.



**Fig. 7:** Tool wear at early cutting (a) and final cutting (b) when  $V = 45$  m/min and  $f = 0.04$  mm/rev

*Tool life:*

Traditionally, tool life is defined by flank wear due to the significant influence this parameter has on the surface finish and dimensional accuracy of the machined part. The tool life was influenced significantly by the temperature generated and the forces exerted at or near the cutting edge of the tools. Therefore, changes in cutting speeds and feed rates will directly influence the cutting forces and temperature generated, especially during dry cutting, and hence the tool life. This had shown in Figure 8 where the highest value for feed rate and cutting speed produced the lowest tool life. Meanwhile in Table 5 show the values of tool life among two types of feed rate on particular cutting speed. In general, the most important point in machining processes is the productivity, achieved by cutting the highest amount of material in the shortest period of time using tools with the longest lifetime (Ahmad Yasir *et al.* 2009).

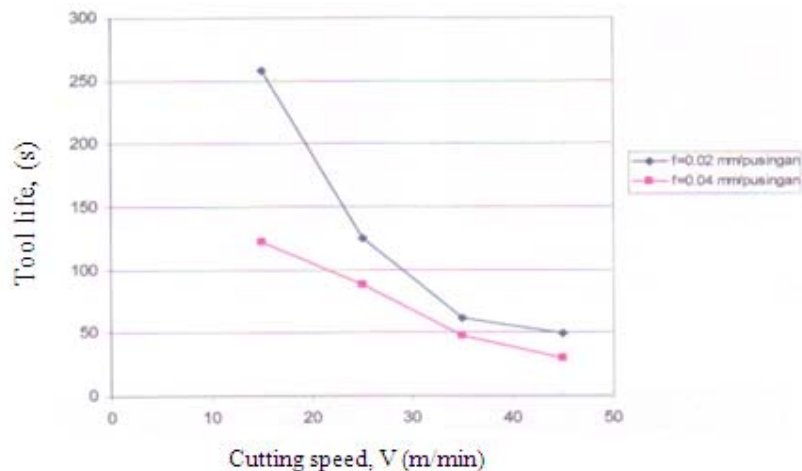

**Fig. 8:** Tool life for different feed rates

**Table 5:** Comparison on cutting time between two values of feed rate

Cutting speed, m/min	Tool life or Cutting time, s		
	F = 0.02 mm/rev	F = 0.04 mm/rev	Different (%)
15	257.97	121.59	52.87
25	124.98	87.20	30.23
35	61.64	47.42	23.07
45	49.10	29.57	39.78

#### Conclusions:

The following conclusions could be made to describe the wear behaviour of the uncoated carbide tool used in turning titanium alloy Ti6Al4V.

1. According to the graph plotted, flank wear on uncoated carbide tool increased by cutting speed and feed rate.
2. Wear progression of uncoated carbide tool is generally in three stages; at the initial stage, followed by gradual stage and finally the abrupt stage of wear. Here the width of flank wear land,  $VB_{avg}$  was set at 0.3 mm where the flank is irregularly worn for the selected work material.
3. The combination of cutting parameters at cutting speed 15 m/min, feed rate 0.02 mm/rev, depth of cut 0.5mm produced the longest cutting time for coated carbide insert approximate 250s or 4 min.
4. Same combination as above but only cutting speed was increased to 45 m/min, it dramatically decreased cutting time to 40s or 0.7min.
5. According to graph, the flank wear rocketed at the final stage probably because the wear process has changed from mechanical wear (abrasion) to thermal wear.

#### Acknowledgment

The authors would like to thank Universiti Teknikal Malaysia Melaka (UTeM) for study financial sponsor. Most appreciation to Universiti Kebangsaan Malaysia (UKM) for the facilities instruments and research financial support.

#### References

- Ahmad Yasir M.S., C.H. Che Haron., J.A. Ghani, and G.A. Ibrahim., 2009. Machinability of Ti-6Al-4V under dry and near dry cutting condition using carbide tools. The Open Industrial and Manufacturing Engineering Journal, 2: 1-9.
- Che Haron, C.H., A. Ginting, & J.H. Goh, 2001. Wear of coated and uncoated carbides in turning tool steel. Journal of Materials Processing and Technology, 116: 49-54.
- Che-Haron, C.H., A. Jawaid., 2005. The effect of machining on surface integrity of titanium alloy Ti-6% Al-4% V. Journal of Materials Processing Technology, 166: 188-192.

- Ibrahim, G.A., Che Haron, C.H., Ghani, J.A., Burhanuddin, Y., Yasir A., El-maghrabi, N., 2007. Performance of cemented carbide tools when turning Ti-6Al-4V ELI under dry cutting condition. EMARC, Universiti Kebangsaan Malaysia.
- Chubb, J.P., J. Billingham., 1980. Coated cutting tools – a study of wear mechanism in high speed machining, *Wear.*, 61: 283-293.
- Jawaid, A., C.H. Che Haron, A. Abdullah, 1999. Tool Wear Characteristics in Turning of Titanium Alloy Ti-6246. *Journal Material Processing and Technology*, pp: 329-334.
- Sulaiman, M.A., C.H. Che Haron, J.A. Ghani, Intan L.R, M.S. Kasim., 2010. The effect of minimal quantity lubrication (MQL) on the surface roughness of Titanium alloy Ti-6Al-4V ELI in turning process, *Journal of Advanced Materials Research*, 146-147: 1750.
- Bonifacio, M.E.R., A.E. Diniz., 1994. Correlating tool wear, tool life, surface roughness and tool vibration in finish turning with uncoated carbide tools, *Wear.*, 172: 137-144.
- Tool Life Testing with Single-point Turning Tools, ISO 3685, 1993.
- Venkatesh., V.C., 1980. Tool wears investigations on some cutting tool materials, *J. Lubrication. Technology*, 102: 556-559.
- Konig, W., R.L. Klinger., 1990. Machining hard materials with geometrically defined cutting edges – field of applications and limitations, *Ann. CIRP* 39(1): 61-64.
- Wellein, G., J. Fabry, 1998. Hard Turning is More Than the Application on CBN. *Cutting Technology Kennametal Hertel*.