

## ARE THERE GENDER-SPECIFIC DIFFERENCES IN ELEMENTARY MOTOR SPEED ABILITY?

Juergen Krug<sup>1</sup>, Gerald Voss<sup>2</sup> and Maren Witt<sup>1</sup>

University of Leipzig, Faculty of Sport Science, Leipzig, Germany<sup>1</sup>  
Universum Academy, Leipzig, Germany<sup>2</sup>

The purpose of this study was to analyse gender-specific differences in elementary motor speed ability. The reliability of 7 tests with 15 items was investigated using intra-class-coefficients. Gender-specific differences of performance were analysed using independent samples t-tests. There were no differences between men and women in elementary motor speed. The structure of the elementary motor speed ability (reaction time, tapping, reactive speed and arbitrarily initiated speed) was investigated with confirmatory factor analysis. Here, we identified gender-specific differences in the structure using structural equation models. The models are characterized with a good model fit. Based on the present findings, conclusions for a gender-specific training of elementary motor speed abilities are derived.

**KEY WORDS:** speed ability, construct validity, gender-specific differences

**INTRODUCTION:** For the structuring of sport performance the general abilities are divided in endurance, strength, speed, flexibility and coordination (Bompa & Haff, 2009). For many years, there have been numerous studies on endurance and strength, but little is known about motor speed components. The differences between power and speed as proposed by Zaciorskij (1968) from the 1960s seem to be completely forgotten. In addition, the terminology of rapid movements is connected with many different concepts such as quickness, speed, agility and power. Sheppard & Young (2006) reported on studies of rapid complex movements. Later they derived for the training of agility and speed the influence of perception and anticipation. Voss, Witt and Werthner (2007) found the existence of elementary motor speed components. These authors arranged (1) reaction time, (2) frequency speed, (3) acyclic speed during reactive movements and (4) non-reactive movements from defined preliminary tension or relative rest as categories of the elementary motor speed ability on an empirical way. Subsequently, Wenzel (2013) defined non-reactive movements as arbitrarily initiated. The aim of the present study was to characterize the general structure of elementary motor speed. Here, we aimed at investigating gender-specific differences in elementary motor speed ability.

**METHODS:** Here, we investigated young participants (sport students) after obtaining written informed consent. The study procedures were approved by the local ethics committee (154-14-14042014). Using the Talent Diagnose System (Werthner Sport Consulting KG, 2016) and self-developed measuring systems the following tests were used to determine the 4 factors of elementary motor speed ability: (1) Simple and complex (choice) reaction time test (hand and foot) to visual and acoustic stimuli, (2) Tapping test (foot), (3) Drop jump test (contact time) and (4) Arm-extension-test (extension time) as well as a brisk forward-step test (arbitrarily initiated speed). Here, a total number of 15 test items were investigated.

**Table 1**  
**Age, Body height and Body mass (M ± SD) of sport student subgroups**

Group	N	Age [yrs]	Body height [cm]	Body mass [kg]
Group 1				
total	78	21.52 ± 3.45	177.18 ± 8.56	70.66 ± 10.34
female	31	21.14 ± 2.95	172.65 ± 9.49	64.03 ± 10.37
male	47	21.77 ± 3.76	180.17 ± 6.41	74.89 ± 7.87
Group 2				
total	214	21.96 ± 2.59	175.87 ± 9.41	69.71 ± 10.95
female	95	21.54 ± 2.47	169.04 ± 6.27	61.67 ± 7.72
male	119	67.40 ± 6.80	181.32 ± 7.82	76.12 ± 8.70

As an initial analysis step, we investigated the test reliability with 78 participants (table 1) by means of intra-class-coefficients (Shrout & Fleiss, 1979) for all test items. Subsequently, the construct validity (214 participants, table 1) was investigated with a confirmatory factor analysis using the Maximum-Likelihood-Method (IBM SPSS Statistics, SPSS AMOS 23). The goodness-of-fit indices by Hu and Bentler (1999) were calculated. Finally, gender-specific differences in task performance and their structure was examined by independent t-tests.

**RESULTS:** The reliability coefficients (ICC) of the tests listed above range from 0.78 to 0.95. According to the literature (Bös, 2001; Hopkins, 2000), the ICC values can be considered as good to very good level for individual analyses. The performances for all speed tests (differentiated in men and women) are summarized in table 2. P-values were Bonferroni corrected (15 items:  $\alpha = 0.05/15 = 0.0033$  for a 5% level). Interestingly, we could not observe gender differences in elementary motor speed (exception foot tapping in standing position). This confirms the speculation of same men's and women's performances realizing elementary motor speed tests with low demands on power or strength.

**Table 2**  
Mean (M), standard deviation (SD) and p-value (independent t-tests) of the 15 test items

Factor	Test	Sex	N	M	SD	P-Value
Simple reaction [ms]	RT_H_vlr	m	80	225.61	19.67	0.86
		f	72	225.08	16.56	
	RT_H_alr	m	80	211.20	19.52	0.11
		f	72	216.65	21.78	
	RT_F_vlr	m	80	244.99	20.00	0.10
		f	72	250.08	18.23	
	RT_F_alr	m	80	230.48	18.37	0.11
		f	72	238.76	21.17	
Complex reaction [ms]	MT_cR_t	m	80	704.09	76.30	0.08
		f	72	725.61	72.06	
	MT_EH_t	m	80	522.83	93.12	0.10
		f	72	547.60	88.38	
	MT_EF_t	m	80	673.59	103.62	0.77
		f	72	678.39	94.16	
Foot tapping [ms]	FT_Ct_l	m	80	85.13	11.50	0.001*
		f	72	91.15	10.77	
	FT_Ct_r	m	80	86.84	14.12	0.03
		f	72	91.88	14.57	
Foot tapping [1/s]	FT_fmax	m	80	12.48	1.04	0.003*
		f	72	11.96	1.05	
Drop jump [ms]	DJ_Ct	m	80	143.34	22.55	0.29
		f	72	139.88	17.00	
Arbitrarily initiated [ms]	Aext_l	m	80	100.00	11.76	0.80
		f	72	100.47	11.73	
	Aext_r	m	80	96.26	12.07	0.07
		f	72	99.81	11.42	
	Step_l	m	80	96.51	15.25	0.16
		f	72	99.88	13.78	
	Step_r	m	80	95.01	15.67	0.26
		f	72	97.75	13.98	

*Note:* RT\_H\_vlr: reaction time hand (visual stimuli, left-right pooled), RT\_H\_alr: reaction time hand (acoustic stimuli, left-right pooled), RT\_F: reaction time foot; MT\_cR: match test complex reaction time, MT\_EH: match test eye-hand reaction time, EF: eye-foot; FT\_Ct\_l: foot tapping contact time left, r: right, FT\_fmax: foot tapping maximum frequency; DJ\_Ct: drop jump contact time; Aext\_l: arm-extension-test left, r: right, Step\_l: brisk forward step-test left, r: right. \* Significant effect.

The theoretical model above with 4 factors was investigated in the next step with a confirmatory factor analysis using all data of male and female subjects. The necessary model goodness-of-fit was reached only after the creation of a second order factor which ties together simple and complex (choice) reaction times. The valid model is based on simple and complex reaction speed, frequency speed and arbitrarily initiated speed. The global fit indices of the model were  $\chi^2 = 86.08$ ,  $df = 85$ ,  $p = 0.447$ ; CFI = 0.99; RMSEA = 0.009; SRMR = 0.071. The local fit indices were used for improving the model fit. Correlations were complemented on the residual variance based on the modification indices. All demands by Hu and Bentler (1999) are fulfilled for a good model fit<sup>1</sup>.

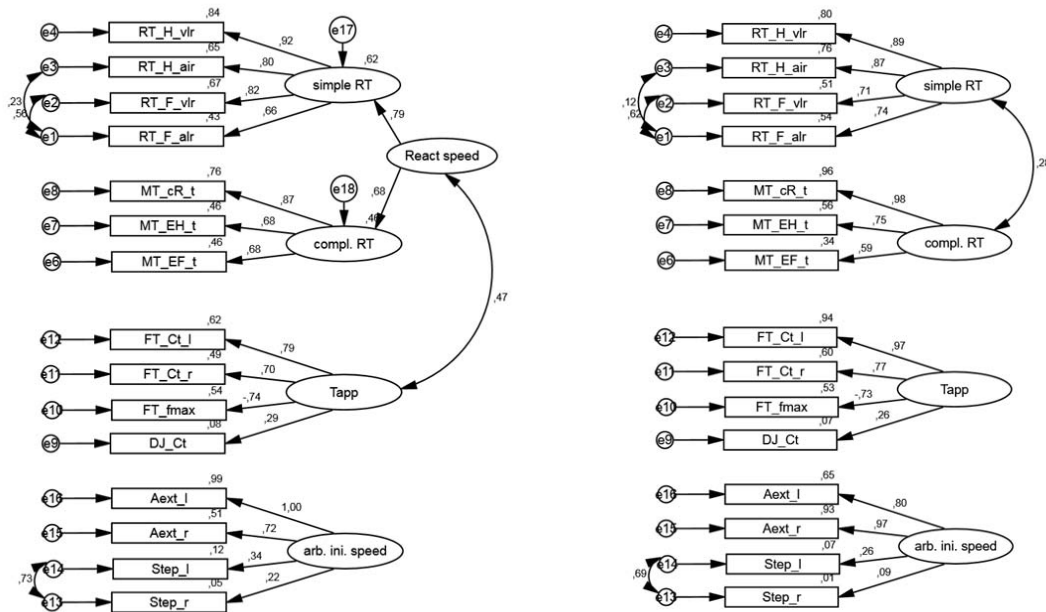

**Figure 1: Structural equation models of elementary motor speed ability with standardized parameter estimation, left: model for male participants, right: model for female participants**

After stratification of our participants in males and females, structural equation models were calculated. For male participants we identified a model (figure 1, left side) with best fit indices ( $\chi^2 = 84.42$ ,  $df = 85$ ,  $p = 0.497$ ; CFI = 1.00; RMSEA = 0.000; SRMR = 0.079). On the other hand, for female participants the same structure is a worse model ( $\chi^2 = 103.06$ ,  $df = 85$ ,  $p = 0.089$ ). Changes of the structure (figure 1, right side) improved significantly the indices. The fit indices are  $\chi^2 = 103.34$ ,  $df = 87$ ,  $p = 0.112$ ; CFI = 0.968; RMSEA = 0.051; SRMR = 0.0856. The demands by Hu and Bentler (1999) are fulfilled with it. Differences in the respective models resulted presumably from bigger independence of the 4 factors. Between the simple and complex reaction speed only low correlative relations exist. This is also significantly different between male and female models ( $z_{\Delta} = -3.62$ ,  $p = 0.00$ ).

**DISCUSSION:** Independent samples t-tests showed no gender-specific differences in elementary motor speed ability. A minor exception was made by 2 parameters of the foot-tapping test in standing position. One obvious explanation might be related to the demands of power and strength which in turn might determine the individual performance in the foot-tapping test. In general, it can be postulated that motor speed performance is not influenced by the factor gender. However, structural equation models revealed gender differences in elementary speed components which, however, are not manifested in performance differences between men and women. More specifically, while the structure of elementary

<sup>1</sup> Fit-Indices by Hu & Bentler (1999): RMSEA  $\leq$  0.08 und SRMR  $\leq$  0.11, CFI  $\approx$  0.95.

speed performance in male participants indicated high correlations between simple and complex reaction times (second order factor) as well as middle correlations with foot-tapping, no such association could be observed for females.

**CONCLUSION:** Here, we provide novel evidence that elementary motor speed is not gender-related except for items of the foot tapping test. Nevertheless, the structure is gender-related. Moreover, future studies should develop additional/ alternative reactive speed tests to better characterize this speed factor. Additionally, we should also consider to incorporate neuromuscular and brain imaging techniques to further characterize and determine elementary motor speed.

However, the introduced results of the study might also be of practical relevance. We suggest that the individual training of the elementary motor speed should be performed differently between males and females. While men should train a combination of the elementary motor speed components (transfer effect), women should train each component subsequently (block periodization).

#### REFERENCES:

- Arbuckle, J. L. (2014). *Amos (Version 23.0) [Computer Program]*. Chicago: IBM SPSS.
- Bompa, T. O. & Haff, G.G. (2009). *Periodization: Theory and Methodology of Training*. Champaign, IL: Human Kinetics.
- Bös, K. (2001). *Handbuch Motorische Tests*. Göttingen: Hogrefe.
- Hopkins, W. G. (2000). Measures of Reliability in Sports Medicine and Science. *Sports Medicine*, 30(1), 1-15.
- Hu, L. & Bentler, P. M. (1999). Cutoff criteria for fit indexes in covariance structure analysis: Conventional criteria versus new alternatives. *Structural Equation Modeling*, 6 (1), 1–55.
- Sheppard, J. M. & Young, W. B. (2006). Agility literature review: Classifications, training and testing. *Journal of Sport Sciences*, 24 (9), 919-932.
- Shrout, P. E. & Fleiss, J. L. (1979). Intraclass Correlations: Uses in Assessing Rater Reliability. *Psychological Bulletin*, 86 (2), 420–428.
- SPSS for Windows 23.0. (2015). *[Computer software]*. Chicago, IL: IBM SPSS.SPSS Inc.
- Voss, G., Witt, M. & Werthner, R. (2007). *Herausforderung Schnelligkeitstraining*. Aachen: Meyer & Meyer.
- Wenzel, U. (2013). *Zu ausgewählten Einflussfaktoren der willkürlich initiierbaren Schnelligkeit. Eine elektro-physiologische und neurostrukturelle Untersuchung*. Berlin: Lehmanns Media Verlag.
- Werthner Sport Consulting KG (2016). Test your talent. Retrieved February 13, 2017, from <http://www.werthner.at/tds/tds-german/>
- Zaciorskij, V. M. (1968). Die körperlichen Eigenschaften des Sportlers. *Theorie und Praxis der Körperkultur*, 17 (Beiheft 1).

#### Acknowledgement

The study was founded by the European Social Fond and the Ministry of Science and Art, Saxony, Germany (Funding Reference Number 100154877).