

2019

## The Influence of Family Functioning on Social Competence, Social Support, and Mental Health Among College Students

Sean Newhart

William & Mary - School of Education, smnewhart@gmail.com

Follow this and additional works at: <https://scholarworks.wm.edu/etd>



Part of the [Counseling Psychology Commons](#)

---

### Recommended Citation

Newhart, Sean, "The Influence of Family Functioning on Social Competence, Social Support, and Mental Health Among College Students" (2019). *Dissertations, Theses, and Masters Projects*. Paper 1563898795.

<http://dx.doi.org/10.25774/w4-d6rh-z193>

This Dissertation is brought to you for free and open access by the Theses, Dissertations, & Master Projects at W&M ScholarWorks. It has been accepted for inclusion in Dissertations, Theses, and Masters Projects by an authorized administrator of W&M ScholarWorks. For more information, please contact [scholarworks@wm.edu](mailto:scholarworks@wm.edu).

**THE INFLUENCE OF FAMILY FUNCTIONING ON SOCIAL COMPETENCE,  
SOCIAL SUPPORT, AND MENTAL HEALTH AMONG COLLEGE STUDENTS**

---

A Dissertation

Presented to

The Faculty of the School of Education

The College of William and Mary in Virginia

---

In Partial Fulfillment

Of the Requirements for the Degree

Doctor of Education

---

by

Sean Newhart

March 2019

**THE INFLUENCE OF FAMILY FUNCTIONING ON SOCIAL COMPETENCE,  
SOCIAL SUPPORT, AND MENTAL HEALTH AMONG COLLEGE STUDENTS**

by

Sean Newhart

---

Approved April 2019 by

Charles “Rip” McAdams, Ed.D.

Chairperson of Doctoral Committee

Thomas Ward, Ph.D.

Patrick R. Mullen, Ph.D.

## Table of Contents

Chapter 1: Introduction .....	2
Background .....	2
Statement of the Problem .....	3
Purpose of the Study .....	5
Significance of the Study .....	6
Chapter One Summary .....	6
Chapter 2: Review of Literature .....	7
Introduction .....	7
Theoretical Framework .....	7
Circumplex Model of Family Functioning .....	7
Social Cognitive Theory .....	9
Attachment .....	10
Social Support .....	12
Influence of Family Functioning on College Adjustment .....	14
Influence of Attachment Relationships on College Adjustment.....	17
Influence of Family Functioning on Students' Interpersonal Relationships .....	19
Social Competence.....	20
Quality of Relationships .....	23
Influence of Social Support on Students' Mental Health .....	27
Influence of Family Functioning on Mental Health .....	31
Chapter Two Summary .....	38
Chapter 3: Methodology .....	39

Sampling Procedures .....	39
Data Collection .....	42
Instrumentation .....	43
Informed Consent Form.....	43
Demographics Form.....	43
FACES-IV.....	44
TSBI.....	45
MSPSS .....	45
MHC-SF.....	46
DASS-21 .....	47
Validity-Check Questions.....	47
Research Questions and Hypotheses .....	48
Data Analysis .....	49
Proposed SEM Model.....	50
Chapter Three Summary .....	50
Chapter 4: Findings.....	52
Participants.....	52
Score Conversions .....	53
Weighting.....	54
Descriptive Statistics.....	54
Research Question #1 .....	56
Confirmatory Factor Analyses.....	57
Structural Equation Model.....	59

Summary .....	64
Research Question #2 and #3.....	64
Research Question #4 .....	64
Family Functioning.....	65
Social Competence.....	65
Social Support.....	66
Mental Health.....	67
Summary .....	70
Chapter Four Summary.....	70
Chapter 5: Discussion .....	72
Discussion of Findings.....	72
Research Question #1 .....	73
Research Question #2 .....	78
Research Question #3 .....	78
Research Question #4 .....	79
Implications for Mental Health Practice .....	82
Limitations .....	84
Recommendations for Future Research .....	85
Conclusion .....	86
Appendices.....	
Appendix A.....	88
Appendix B .....	97
References.....	106

## **Acknowledgements**

I'd like to thank all of the wonderful friends and family that have supported me through the dissertation process and my overall educational journey. Thanks to all of the faculty in the School of Education, especially Drs. McAdams, Mullen, Ward, Gutierrez, and Brendel. Furthermore, thanks to all of my wonderful peers in the School of Education, including Colin Vaughn, Laura Pignato, Kat Sperandio (who won the battle and maybe the war), Leah Horrell, Dave Gosling, Jeremy Goshorn, Nancy Chae, Victor Tuazon, and Nate Wagner. I'd also like to thank my colleagues that have supported me throughout my educational journey, including Dr. Corrinne Sackett, Dr. Sterling Travis, Kevin Joyce, and all of the wonderful master's level students I met at William & Mary. Finally, I'd like to thank my family and friends, especially my partner Jennifer Vetter, my parents Mike and Ann Newhart, my siblings Scott and Allison Newhart, and my friends Beau Wengert and Austin Conrad, along with all of the other wonderful people who have encouraged me to pursue my education.

**THE INFLUENCE OF FAMILY FUNCTIONING ON SOCIAL COMPETENCE,  
SOCIAL SUPPORT, AND MENTAL HEALTH AMONG COLLEGE STUDENTS**

**ABSTRACT**

There are a multitude of factors that influence college students' mental health. Among such factors, there is little research on the influence of family functioning, social competence, and social support on the mental health of college students. This quantitative research study examined the relationships among the identified variables utilizing structural equation modeling. Results indicate that although there are relationships between each variable, the a priori theoretical model established by the researcher did not fit the data well. Implications for mental health practitioners and researchers are explored in light of the researcher's findings.

SEAN NEWHART

DEPARTMENT OF SCHOOL PSYCHOLOGY AND COUNSELOR EDUCATION

COLLEGE OF WILLIAM AND MARY IN VIRGINIA



THE INFLUENCE OF FAMILY FUNCTIONING ON SOCIAL COMPETENCE,  
SOCIAL SUPPORT, AND  
MENTAL HEALTH AMONG COLLEGE STUDENTS

## **CHAPTER ONE**

### **INTRODUCTION**

#### **Background of the Problem**

Over the past 15 years, researchers have found evidence to support an upward trend in the severity and prevalence of mental health problems among college students in the United States (e.g., Benton, Robertson, Tseng, Newton, & Benton, 2003; Erdur-Baker, Aberson, Barrow, & Draper, 2006; Reetz, Bershad, LeViness, & Whitlock, 2016; Xiao et al., 2017). Most recently, Xiao and colleagues (2017) found that students reported significant increases in mental health history, harm to others, past trauma, and substance use over a period of five years. Furthermore, upward trends were found for suicide, self-harm issues, depression, generalized anxiety, social anxiety, and distress over time. Concurrently, the mean number of appointments and students seeking counseling services increased an average of 30 % every year. Thus, the mental health of college students seems to be declining over time, resulting in an increased need for mental health services on campus.

Mental health problems can influence numerous factors related to college success, including executive functioning (e.g., planning, organizing, making decisions), stigmatization, interacting with groups, attendance, and motivating oneself and others (Collins & Mowbray, 2005). Therefore, understanding factors that influence students' mental health is essential to providing support for them as they navigate the complexities of college life. The biopsychosocial model (BPS; Engel, 1977) has been used to consider

the biological (e.g., physical, biochemical, genetic), psychological (e.g., personality, behavior, mood), and broad social factors (e.g., socioeconomic, familial, cultural) in the etiology of mental health and illness. Biologically, children's brains are in transition, with changes that are central to the development of higher-order cognition and emotionality (Kay, 2010). Gradual increases in cortisol, a hormone released in response to stress, may also influence the development of emotional or psychological difficulties during adolescence (Spear, 2000). These biological changes during adolescence contribute to the potential for mental health or pathology during the college years.

Specific psychosocial factors are also salient as students begin college. Eichler (2006) highlighted the importance of the second separation-individuation phase, in which college students begin to consolidate their self-concept. Furthermore, college students often begin to seek out and sustain mature interpersonal relationships with others. This process can be influenced by earlier interpersonal relationships, such that students entering college with little experience with successful relationships may be challenged by new social opportunities, which can limit the college experience. College students must also balance newfound independence with connectedness to their families. These factors make up a developmental transition to college that offers many opportunities for growth as well as risks for mental health difficulties.

### **Statement of the Problem**

While multiple factors must be considered regarding the mental health of college students, one area of concern that has not been adequately addressed in the literature is the influence of the family of origin on college students' mental health. Researchers have related the influence of parent and family relationships to a broad range of student

functioning, including autonomy and self-efficacy (e.g., Reed, Lucier-Greer, & Barber, 2015), academic self-concept (e.g., DeDonno & Fagan, 2013; Lustig, Xu, & Strauser, 2017), and well-being (e.g., Uruk, Sayger, & Cogdal, 2007). Furthermore, researchers have found empirical support for the influence of family of origin on presenting problems in college counseling centers (e.g., Brack, Brack, Charbonneau, Hill, 2002; Hoffman & Weiss, 1987; Johnson, 1993), especially depression (e.g., Lopez, Campbell, & Watkins, 1989; Ponappa, Bartle-Haring, Holowacz, & Ferriby, 2016; Reed et al., 2015). Family dynamics also play an important role in the prevention of mental health problems (Merianos, Nabors, Vidourek, & King, 2013) and the development of peer (Robinson, Garthoeffner, & Henry, 1995) and romantic relationships (Ryan, Franzetta, Schelar, & Manlove, 2009). Research suggests that developing supportive social networks in college is also important to college student mental health (Hefner & Eisenberg, 2009); relationships that typically begin in the family of origin.

Despite the importance of the family of origin on college students' mental health, parents and other close family members are often not included in counseling center outreach efforts (Eichler & Schwartz, 2010). A lack of consideration for the influence of the family on the mental health of college students has been attributed to several factors, including (a) the predominance of developmental perspectives valuing separation from the family during young adulthood (Alishio, 1992), (b) stereotypes and reactions to "helicopter parents" (Haber & Merck, 2010), and (c) privacy concerns related to the Family Education Rights and Privacy Act (FERPA) and the Health Insurance Portability & Accountability Act (HIPAA; Girard, 2010). Regardless of these influential factors, the identification of family problems as a primary presenting concern among students

(Center for Collegiate Mental Health, 2018) as well as the significant influence of family dynamics on numerous factors during early adulthood and college life highlight the need to understand students' mental health needs from a family perspective.

Our current understanding of college students' mental health is often limited by a focus on the individual student to the exclusion of the family of origin. Family functioning can directly influence students' mental health (Center for Collegiate Mental Health, 2018), while also affecting students' ability to build peer and romantic relationships (Ainsworth, Blehar, Waters, & Wall, 1978; Bandura, 1986). In turn, students' ability to build and utilize social support from peers and families may be affected by family functioning, which can also influence their mental health (e.g., Hefner & Eisenberg, 2009; Reuger, Malecki, Pyun, Aycock, & Coyle, 2016). Based on the relationships between family functioning and interpersonal functioning, the aim of the proposed study was to explore the influence of family functioning on college students' mental health through the lens of social competence and social support.

### **Purpose of the Study**

The specific purpose of this study was to explore the potential relationships between family functioning, social competence, social support, and mental health among a sample of U.S. college students. Survey research was conducted to make inferences from the study sample to the larger population of college students across the United States (Fowler, 2013). A representative sample of institutions was first built using the Integrated Postsecondary Education Data System (National Center for Education Statistics, 2017). The researcher then contacted institutions to obtain student directory information to build the sample.

Following the building of a representative sample, the researcher utilized the tailored design method for web and mobile questionnaires (Dillman, Smyth, & Christina, 2014) to contact and recruit participants for the study using Qualtrics Survey Software. Participants completed five instruments related to the variables of interest as well as a demographic form. Following the completion of data collection, data was transferred to IBM's Statistical Package for the Social Sciences (SPSS). Analyses included descriptive statistics, analysis of variance (ANOVA), and structural equation modeling (SEM). The SEM was then analyzed and visually represented through the Amos program for SPSS.

### **Significance of the Study**

The proposed study addressed gaps in the extant literature regarding the influence of family functioning on the mental health of college students. Specifically, the relationships among the four variables of interest (i.e., family functioning, social competence, social support, mental health) have never been examined in a single model. Furthermore, while most studies have identified mental health as the presence or absence of symptomatology, this study defines mental health on a spectrum from symptomatology to well-being. Thus, the researcher attempted to examine the potential negative and positive effects of the variables of interest. Overall, it is hoped that the model can provide a more comprehensive understanding of how the family of origin, directly and indirectly, influences students attending college.

### **Chapter One Summary**

Chapter one introduced the research problem in the context of background data. Chapter one then reviewed the purpose of the study and how it will contribute to the literature base. Chapter two presents a literature review regarding the research problem.

## **CHAPTER TWO**

### **LITREATURE REVIEW**

Chapter two first covers the primary theoretical frameworks that guided the research questions and subsequent methodology, including theories of family functioning, social cognitive theory, attachment, and social support. A review of relevant literature is then introduced to provide support for the justification of the research study as well as the relationships between the variables of interest. Each body of literature is reviewed in light of its strengths and limitations. The chapter ends with a summary of the literature related to the primary research question.

#### **Theoretical Framework**

##### **Circumplex Model of Family Functioning**

Developed by Olson, Russel, and Sprenkle (1989) to address the gap between research, theory, and practice in marital and family therapy, the Circumplex Model (CM) is specifically designed for clinical assessment, treatment planning, and research on outcome effectiveness of marital and family therapy (Olson, 1996). Incorporating over fifty concepts used by theorists to describe marital and family dynamics, Olson (2000) identified three dimensions of family functioning in the CM, including (a) family cohesion, (b) family flexibility, and (c) family communication, each of which contributes to the function or dysfunction of family systems. The general hypothesis of the CM is

that families with balanced levels of cohesion and flexibility will generally function more adequately than families with unbalanced levels of these dimensions.

**Marital and family cohesion.** Family cohesion is described as the emotional bond that family members have towards one another. Specific variables of cohesion include emotional bonding, boundaries, coalitions, time, space, friends, decision-making, interests, and recreation. The focus of this dimension is how families balance separateness versus togetherness. There are four levels of cohesion ranging from disengaged (very low), to separated (low to moderate), to connected (moderate to high), to enmeshed (very high). The CM hypothesizes that balanced cohesion, represented by the separated and connected levels, indicates optimal functioning, such that individuals can be both independent from and connected to their families. Extremely high (i.e., enmeshed) or low (i.e., disengaged) cohesion are often problematic over the long term.

**Marital and family flexibility.** Family flexibility is described as the amount of change in the family's leadership, roles, and rules. Variables that contribute to flexibility include leadership, control, discipline, negotiation styles, role relationships, and relationship rules. The focus of this dimension is on how systems balance stability versus change. There are four levels of flexibility ranging from rigid (very low), to structured (low to moderate), to flexible (moderate to high), to chaotic (very high). The ability to change when appropriate discriminates functional families from dysfunctional families. As with the cohesion dimension, family systems with balanced levels of flexibility (i.e., structured or flexible level) tend to be more functional over time, while unbalanced families (i.e., rigid or chaotic level) may be problematic.



**Marital and family communication.** Family communication is considered a facilitating dimension, as it is critical to movement on the dimensions of cohesion and flexibility. The focus of communication is on how the family utilizes listening skills, speaking skills, clarity, continuity tracking, respect, and regard. Empathy, attentive listening, and respect for the affective component of communication are important for family communication. In support of the model, couples and families with balanced levels of cohesion and flexibility tend to have very good communication compared to families with unbalanced levels (Rodick, Henggler, & Hanson, 1986).

Evidence of the validity of the CM has been established through its conceptual relation with other theories of family functioning such as the Beavers System Model (Beavers & Hampson, 2000) and the McMaster Family Model (Miller, Ryan, Keitner, Bishop, & Epstein, 2000). Empirical and statistical validation of the model has been established through the self-report Family Adaptability and Cohesion Evaluation-IV (FACES-IV; Olson, 2011), with more than 250 studies that support the general hypothesis of the model (Olson, 2000). Furthermore, the FACES-IV has shown to have discriminatory power in distinguishing between problem families and non-symptomatic families. Researchers have also found that more balanced families, indicated by FACES-IV scores, have demonstrated better communication skills than unbalanced families. Thus, studies utilizing the CM indicate that it is a theoretically and empirically supported model to conceptualize family functioning.

### **Social Cognitive Theory**

Social cognitive theory (SCT) was developed and refined by Bandura (1986) and describes human behavior as the result of the interaction between intrapsychic factors and

social environments. SCT posits that human functioning is influenced by the triadic model of reciprocal causation, which asserts that (a) personal factors, (b) environmental factors, and (c) behavior influence one another bidirectionally. Personal factors are defined as cognitive, affective, and biological events within the individual.

Environmental factors are defined as the multitude of social situations that individuals experience and behavior is defined as the broad range of behavioral patterns expressed. The ways these three factors interact are contextually and developmentally specific and require considerations of complex interactions of person, environment, and behavior.

Unlike deterministic models of human behavior, SCT asserts that humans actively shape and contribute to their own development. Individuals do so by selecting alternative environments or creating their own environments. Humans also learn by observation and modeling, such that they acquire new skills or modify old behavior by observing others. Behavior is also guided by internal standards, which are developed from personal (e.g., dispositional) and environmental (e.g., cultural, societal) influences. People are typically motivated to behave in ways that are congruent with their internal standards.

SCT is highlighted in family systems, as the family of origin is often the initial model of behavior. Specifically, children often learn to interact with others based on their interactions with the family. Learned social behaviors from the family of origin may also continue to be utilized into adulthood (Whitbeck, Hoyt, & Huck, 1994). Therefore, SCT provides a theoretical foundation for the way college students' build interpersonal relationships based on family functioning.

### **Attachment**

Attachment theory is the prevailing paradigm for understanding social development among children. Conceived by John Bowlby (1969) and later expanded upon by Mary Ainsworth (Ainsworth, Blehar, Waters, & Wall, 1978), attachment theory asserts that infants are born with certain behaviors that are utilized to maintain closeness to caregivers. Similar behaviors continue to be utilized into adulthood to maintain closeness with significant others. If attachment behaviors are successful, they can result in a felt sense of security in which an infant feels secure enough to explore their environment and relationships with others. Caregivers encourage attachment by being attuned and responsive to an infant's needs, especially in times of distress.

Attachment needs from the infant include: (a) physical proximity to the attachment figure, (b) distress at separation from the attachment figure, (c) retreating to the attachment figure in times of danger or anxiety, and (d) provision of a secure base by the attachment figure from which infants can explore their environment. Attachment relationships typically form within the first two years of life between the infant and their primary caregiver. Attachment relationships influence an internal working model of understanding the self, relationships, and world. The internal working model can often be observed in the form of an attachment style, a primary pattern of interpersonal relating that often persists into adulthood and beyond.

Initially, attachment styles were thought to exist in three categories, including secure, insecure anxious-ambivalent, and insecure anxious-avoidant. Secure attachment is characterized by feelings of emotional intimacy, security, and physical safety to the attachment figure, leading to adults who enjoy connection to others, trusting that others can and will meet their emotional needs. Anxious-ambivalent attachment is a type of

insecure attachment characterized by an inflated need for feelings of safety and security due to inconsistent responses from the attachment figure. Among adults, anxious-ambivalent attachment manifests through eliciting of caretaking behaviors from significant others, overvaluing the importance of relationships, and monitoring of close others. The third attachment style, anxious-avoidant, is an insecure style in which children have attachment figures who are minimally close and lacking emotionally expressive communication. In adulthood, anxious-avoidant attachment is manifested by undervaluing of relationships, withdrawal, and emotional distance. A fourth attachment style, disorganized, was later added to describe attachment styles of abused children, often resulting in difficulty regulating emotions and maintaining relationships due to fear.

Attachment styles are theorized to persist into adulthood, and a substantial body of research exists to support this (Mikulincer & Shaver, 2007). Thus, attachment relationships with parents will likely be replicated when students begin forming new relationships in college. Although attachment is not a specific variable in this study, the theory sheds light on the influence of an individual's relationships with family members (i.e., parents) and interpersonal functioning. Based on attachment theory, students with close family relationships will likely have the capacity to develop close relationships in college, potentially impacting their social competence and perceived social support.

### **Social Support**

Social support has been defined as “the social resources that persons perceive to be available or that are actually provided to them by nonprofessionals in the context of both formal and informal helping relationships” (Cohen, Gotlieb, & Underwood, 2000, p. 4) and has been empirically supported as a factor that influences mental health and well-

being (Thoits, 2011). Social support has been identified in two contexts, with perceived social support identified as the subjective feeling of being supported by one's relationships and received support referring to support actually provided by others (Santini, Koyanagi, Tyrovolas, Mason, & Haro, 2015). Social support has been theorized as serving two different functions. The general benefits (GB) model asserts that social support can offer benefits through an increased sense of well-being and promotion of positive psychological factors, including self-worth, purpose, and positive affect. The GB model also posits that social support reduces negative affect based on the promotion of positive affect (Cohen, 2004). The GB model is often compared to the stress-buffering (SB) model, which posits that social support mediates the influence of stress. Those with limited social support are impacted more by stress than those with adequate support. Thus, in the SB model, social support primarily serves as a mediator between stress and psychopathology.

Social support has often been studied in relation to depression. A metaanalysis of studies examining the relationship between social support and depression among adults indicated that perceived social support was more important than received support and played a protective role against depression across the general population (Santini et al., 2015). Another meta-analytic review of social support examined perceived social support and depression in childhood and adolescence (Reuger et al., 2016). Findings indicated that social support had a moderate overall effect size on depression across studies and that reports were consistent with the general benefits model. Furthermore, family support was demonstrated as the most important source of social support across all ages.

Therefore, social support may be an important factor influencing the mental health of college students.

Each of the theories underlying this study needs to be examined in light of their strengths and limitations. Although normed on a convenience sample of nonclinical families, the CM of family functioning has been supported by over 250 studies utilizing FACES (Olson, 2000). The strong research foundation, as well as clinical utility, seems to indicate that the CM is empirically validated. Attachment theory has also been well validated regarding infant (see Cassidy, Jones, & Shaver, 2013) and adult (Mikulincer & Shaver, 2007) attachment styles and their influences on development, mental health, and social behavior. Social cognitive theory has been studied across many fields, including education, communication, information systems, and psychology. Although some of the concepts of SCT are difficult to study, and some parts of the theory are loosely connected, there has been a large amount of research accumulated to support several concepts of the theory (e.g., self-efficacy, modeling, behavior) (Schunk, 2012). Evidence also exists for the construct of social support as a buffer to stress and symptoms of mental health among adolescents (Reuger et al., 2016) and the general population (Santini et al., 2016). Thus, the theories discussed here seem to provide a valid and practical framework for this study.

### **Influence of Family Functioning on College Adjustment**

Family functioning has been shown to influence students' adjustment to academic, social, and developmental tasks associated with college life. Although college adjustment has no single operational definition, Mattanah, Lopez, and Govern (2011) identified "mega domains" by categorizing constructs identified in the college adjustment

literature, including: (a) academic motivation and competence, (b) interpersonal competence, (c) stressful affects and high-risk behaviors, (d) self-worth, and (e) developmental advances. It can be seen that adjustment covers a wide array of outcomes related to explicit and implicit tasks inherent in the college environment. Relationship quality with family members and specific family patterns have been shown to influence students' adjustment.

There is a multitude of intrapersonal and interpersonal factors that predict students' adjustment to college. Holmbeck and Wandrei (1993) conducted a study with freshman students examining the relationship between a college adjustment and a multitude of individual and interpersonal factors. Canonical correlation analyses revealed that generally, separation-individuation issues, family relations, and personality variables were more highly predictive of adjustment than perceptions of leaving home or actual home-leaving status. The researchers concluded that the capacity to regulate a healthy balance of separation-individuation, to maintain quality family attachments and perceptions of adaptability were all important to adjustment. Results from this study indicate the importance of family relationships and individual factors for new students adjusting to the college environment.

Along with the quality of family bonds, conflict in the family of origin has been shown to influence students' adjustment to the college environment. Lopez (1991) studied the influence of family conflict on college students' perceptions of adjustment according to the Student Adaptation to College Questionnaire (SACQ; Baker, McNeil, & Siryk, 1985). Using multivariate and univariate analyses of variance, the researcher found support for the influence of students' gender and family marital conflict on perceptions of

personal adjustment. The results also supported a significant relationship between four distinct family alignments and the four areas of adjustment on the SACQ, including academic, personal-emotional, social, and institutional attachment adjustment. Thus, family conflict and patterns of family interaction can influence students across an array of constructs related to adjustment.

More recent studies examining the influence of family functioning on college adjustment have incorporated biological and social markers of adjustment. Gans and Johnson (2016) conducted a study involving emerging adults' cortisol responses in family interaction, internalizing behavior, and emotional adjustment during the transition to college. Using biological data from saliva, a coding system to assess observed family relatedness, and two self-report instruments, the researchers found support for the family environment serving as a "secure base" for participants. Emerging adults appeared to experience their family as a respite, as they displayed lower levels of cortisol during family tasks compared to completing a task individually. Observed family functioning also moderated the relationship between cortisol response type and later anxiety. However, neither cortisol response pattern nor observed family functioning independently predicted later internalizing symptoms. Thus, cortisol response in a family context may be predictive of later adjustment specifically related to anxiety. Although studies including biological evidence are not as common in family research, this study offers supporting evidence for the influence that family functioning can have on emerging adults in college.

This body of literature should not be presented without a critique of its strengths and limitations. While Lopez (1991) found that marital conflict and family alignment was



related to measures of adjustment, the research methodology limited generalizability of the results and any ability to establish causation. Holmbeck and Wandrei (1993) found strong support for a highly predictive relationship between family functioning on adjustment in college. However, generalizability is limited to the larger population of college students based on a homogenous sample (i.e., freshmen college students from one course at one university) and the researchers were unable to establish causation due to the cross-sectional methodology.

Of the literature presented, the study by Gans and Johnson (2016) seems to provide the strongest support for the influence of family functioning on college students' adjustment, as it utilizes multiple sources of evidence (i.e., observational, physiological, self-report). Furthermore, the use of latent growth modeling analysis provided support for causality. As with the other studies cited in this section, this study was also limited in that it only utilized data collected from college students at one university, thus limiting generalizability. Despite the limitations of these studies, their results provide support for the idea that family functioning continues to influence college students' adjustment even when they are living outside of the home while attending school. Thus, family functioning can influence adjustment positively and negatively.

### **Influence of Attachment Relationships on College Adjustment**

While some researchers have focused on global patterns of family interaction in relation to college students' adjustment, others have examined adjustment to college's relationship with more specific constructs, and especially attachment. Kenny and Donaldson (1991) explored the relationship between attachment to parents, family structure, and the social and psychological functioning of first-year college students. The

researchers found that women described themselves as being significantly more attached to their parents than men and that women described the affective quality of their attachments as being more positive. Female participants also indicated that their parents played a greater role in providing emotional support than male participants. Significant positive relationships were indicated between attachment, social competence, and psychological well-being among women. Conversely, family anxiety around separation and marital conflict were related to psychological symptoms among women.

The results of this study highlight the way attachment relationships influence psychological well-being in college women through direct (i.e., emotional support) and indirect (i.e., social competence) mechanisms. Limitations of this study included the small sample of males, which limited the ability to analyze data regarding this sample. Furthermore, the sample consisted of students from one, primarily white private university, limiting generalizability. The cross-sectional nature of the study also limits the ability to make causal inferences. However, the results of this study provide useful evidence for a relationship that exists between students' attachment to their family, their perceived social competence, and their subsequent mental health.

Along with studies examining both family functioning and attachment, a large body of research has examined attachment specifically in relation to a wide array of adjustment outcomes. Mattanah, Lopez, and Govern (2011) conducted a meta-analysis of studies evaluating the relationship between parental attachment bonds and the development and adjustment of college students. Using the results of 156 studies from 1987 to 2009, the body of research revealed a small-to-moderate relationship between parental attachment across a broad range of college adjustment outcomes. The results

also supported attachment as being equally predictive across academic motivation and competence, interpersonal competence, stressful affects and high-risk behaviors, self-worth, and developmental advances. Furthermore, gender of parent, gender of student, ethnicity, nationality, and year in school did not moderate the overall attachment-adjustment relationship. This meta-analysis supports the notion that parent-child relationships are important to college student functioning and adjustment across a broad array of tasks associated with the college experience. Limitations of the study included the use of only self-report measures, which can result in response bias or other error. The literature used in the study also primarily consisted of cross-sectional designs, disallowing the establishment of causality. Finally, the small to medium effect size of attachment indicates that there are many other factors that influence adjustment.

In review, students' adjustment to college is influenced by patterns of global family functioning and specific family relationships (i.e., attachment) across a broad range of outcomes. Interpersonal factors related to the family are especially apparent when students' leave for college and must adjust to the new environment. Attachment styles also seem to be activated as the student enters a new college environment. Patterns of family relations and conflict can also impact students' adjustment while they are away at school. The family can provide resources or limit students' attempts to adjust to the college environment.

### **Influence of Family Functioning on Students' Interpersonal Relationships**

While the saliency of specific aspects of adjustment depends on the individual, one aspect of college adjustment that is consistently highlighted in the literature is interpersonal competence. Family systems (Reiss, 1981), attachment (Waters, Hamilton,

& Weinfield, 2000), and social cognitive theories (Bandura, 1986) posit that individuals often learn and internalize social behaviors from their family, which are then used to build peer networks and romantic relationships. A significant body of research has supported these theories, particularly the influence of family functioning on social competence, relationship quality, and relationship status. Thus, the family system can influence students' directly through family functioning as well as indirectly through past learned behaviors and global attachment styles.

### **Social Competence**

The influence of family functioning on social competence has often been studied with freshmen college students, who must adapt to a novel social environment upon matriculation. Bell, Avery, Jenkins, Feld, and Schoenrock (1985) investigated the relationships between reported closeness to family members and perceived social competence among a large group of freshmen from two large public universities. After controlling for demographic variables, the researchers found a significant positive relationship between intrafamily affect and social competence. Close relationships with parents were associated with greater satisfaction in peer relationships. The researchers also reported the importance of the overall family environment rather than specific familial relationships in relation to social competence. Results from this study support the notion that intimacy among family relationships is reflected in students' perceived social competence, indicating that family functioning may influence interpersonal functioning of students in the college environment.

Attachment may also play an important role in college students' social competence and subsequent adjustment. Holt (2014) assessed the relationship between

parent and peer attachment, academic help-seeking, social competence, self-compassion, and adjustment to college among a sample of first-year college students. Using three separate regression models, the researcher reported that: (a) the relationship between attachment security and adjustment was mediated by attitudes about academic help-seeking; (b) self-compassion predicted personal and emotional adjustment, although this was not related to attachment; and (c) social competence mediated the relationship between attachment and social adjustment, but not the relationship between attachment and personal/emotional adjustment. It, therefore, seems that attachment plays an important role in social competence and subsequent social adjustment in college, which supports the notion that attachment styles are activated by students when forming new relationships.

While some researchers have examined the positive influence of family affective bonds, others have focused on how negative family interactions influence interpersonal competence. Rhoades and Wood (2014) examined the role of family conflict and emotional distress about one's family in social adjustment among a sample of college students. Structural equation modeling indicated that more positive and less negative feelings about one's family were associated with greater self-reported dating competence, more social assertiveness, and greater intimacy in relationships. Furthermore, a model in which emotional distress mediated the association between conflict with family and social adjustment was found to fit students who came from divorced and nondivorced families. The researchers' findings support the notion that among college students, positive feelings about one's family of origin may be related to social competence and greater intimacy in relationships, while family conflict can influence social adjustment.

Specific patterns of family functioning and lower social competence may also lead to negative mental health outcomes. Kumar and Mattanah (2018) surveyed a sample of college students regarding their perception of interparental conflict and parental intrusiveness, their romantic competence, and their self-report of depression and loneliness. Using correlations and multiple regression, results revealed a positive relationship between depressive symptomatology and loneliness. Parental intrusion and romantic competence also mediated the relationship between interparental conflict and depression symptomatology and partially mediated the link with loneliness. Interparental conflict and parental intrusion also seemed to interfere with participants' competence in romantic relationships. Thus, interparental conflict and parental intrusion may influence romantic competence as well as depression and loneliness, which can further impact the ability to build interpersonal relationships.

While many researchers have found support for a link between family functioning and social competence, others have found little to no change in the relationship between these variables over time. Sun, Bell, Feng, and Avery (2000) explored the influence of parental bonds on college students' relational competencies. In a longitudinal survey, students completed questionnaires once during their first year and again during their senior year. Utilizing a mixed model univariate analysis of variance, the researchers reported no significant change in parental relationships over the college years. Furthermore, there was no evidence for the strengthening or weakening of the moderate association between parental bonds and relational competencies from freshman to senior year, and there were no differences in bidirectional associations across time. Results

supported the notion that students' bond with their parents and the parents' influence on social competence may remain relatively stable while they complete college.

Overall, the literature presented in this section provides support for both the positive (i.e., Bell et al., 1985; Holt, 2014) and negative (i.e., Kumar & Mattanah, 2018; Rhoades & Wood, 2014) influence of family functioning on social competence. A primary limitation of the presented studies was a lack of generalizability, as most studies utilized primarily Caucasian student samples from a small number of universities. Furthermore, these studies utilized cross-sectional designs, limiting the ability to make causal inferences. One study (Sun et al., 2000) addressed the latter limitation by utilizing a longitudinal methodology with a sample of students from freshman to senior year. However, the researchers found no evidence for strengthening or weakening of the relationship between parental bonds and relational competencies across time. Thus, there are also discrepancies among findings regarding the influence of family functioning on social competence. Despite these limitations, these studies provide evidence for the existence of a relationship between family functioning and social competence among college students, which also supports the theoretical tenets of social cognitive theory.

### **Quality of Relationships**

The quality of relationships in the family system can be reflected in students' peer relationships. Mounts, Valentiner, Anderson, and Boswell (2006) examined the relationships among shyness, sociability, parental support, loneliness, anxiety, and depression in a sample of freshman students. Utilizing hierarchical regressions, the researchers reported that high levels of shyness, low levels of sociability, and low levels of parent support predicted higher levels of loneliness. Results also indicated that

loneliness was significantly related to anxiety and depression. Conversely, higher levels of parental support were related to higher levels of friendships quality. It seems that parental support can influence multiple factors related to social behavior including feelings of loneliness as well as the quality of friendships among college students.

Family connectedness can also have a significant impact on the way that adolescents interact with their peers. Bell, Cornwell, and Bell (1988) explored how familial patterns of connectedness would be reflected in peer relationships of adolescent daughters. Using a variety of survey and observational methods, the researchers discovered a significant correlation between family connectedness and peer connectedness. More specifically, adolescent girls from families described as overly close had a higher percentage of friendship choices reciprocated, while adolescent girls describing their family as isolated had a lower percentage of their friendship choices reciprocated. The researchers also observed that adolescent girls appeared to select and influence their own friendships in ways that reflected the quality of functioning in their family of origin. Results suggested that patterns of functioning and attachment in the family of origin can often be reflected in adolescents' peer relationships.

While overall family connectedness exerts a significant influence on adolescents' relationships, parenting style may influence relationship quality through self-concept. Dekovic and Meeus (1997) interviewed families from the Netherlands to examine how parenting influenced adolescents' self-concept. Using surveys conducted in the home, the researchers were able to obtain a variety of information regarding peer relations, self-concept, and the parent-adolescent relationship from multiple family members. Exploratory factor analysis and regression analysis revealed that the quality of parent-



adolescent relations appeared to bear a stronger link to the quality of peer relations than to involvement with peers. Results also indicated that adolescents' self-concept served as a mediator between maternal child-rearing style and involvement with peers. These results suggest that parenting style may influence adolescents' self-concept in a way that affects interaction and quality of relationships with peers.

While many researchers have found a significant link between family and peer relationship quality, others have found this link to be tenuous. In a longitudinal study, Rice and Mulkeen (1995) examined adolescents' relationship with parents and peers from 8<sup>th</sup> grade to four years after 12<sup>th</sup> grade. Using repeated measures analysis of variance with linear and quadratic trend analyses, correlations, and multiple regression analysis, the results indicated that adolescents increased in intimacy with both their parents over time, although patterns of intimacy were different for differing relational dyads. However, there was a minimal interdependence found between adolescent-parent and adolescent-friend intimacy. Whereas relationships between adolescents and their parents may increase over time, that increased intimacy may not exert a significant influence on adolescents' peer relationships.

Disruption of relationships in the family of origin can impact adolescents' peer relationships. Lauer and Lauer (1991) recruited a diverse sample of participants to explore the influence of family backgrounds on relationship status and quality. Results supported a significant difference among groups; specifically, participants who reported coming from disrupted families were more likely to be in an intimate relationship than those who reported coming from intact-happy families. However, there were few differences found between adults from various backgrounds on factors such as self-

esteem, social competence, dating behavior, and relational attitudes. Despite the lack of differences, two-thirds of respondents reported negative consequences of family disruption that impacted their ability to relate to others. Disruptions in the family of origin appear to influence the tendency to be in an intimate relationship as well as self-perceptions of how one relates to others.

Among disruptions in the family of origin, divorce may be particularly influential for relationship quality. Robinson, Garthoeffner, and Henry (1995) surveyed college students regarding their family relationships, self-esteem, conflict resolution, and interpersonal relationship quality. Multiple regression analysis indicated that participants' parents' marital status was mediated by relationship anxiety in predicting interpersonal relationship quality. This interaction was particularly strong for young adults with divorced parents. Furthermore, family adaptability and conflict management skills were found to be positively related to interpersonal relationship quality. These results support the notions that overall family functioning is important to interpersonal relationship quality, while divorce may lead to relationship anxiety and influence relationship quality among college students.

Along with marital status, parental conflict can also significantly impact students' perceptions of relationships. Green and King (2009) conducted survey research with college students to explore the influence of parental marital status and past parental conflict on participants' best friendships in college. Through univariate analysis of variance, the researchers reported that students from families of divorce described their best friendships as less affirming and favorable, although this effect was also influenced by domestic abuse. College students who reported experiencing domestic abuse described

their best friendships as less affirming, less practically useful, and more difficult to maintain than students from intact family systems. The findings suggest that divorce and past domestic abuse can continue to influence individuals' perceptions of relationships in college.

The body of research presented in this section supports the influence of family functioning and family relationships on the ability of adolescents and young adults to build quality peer and romantic relationships with others. Although there is contradictory evidence regarding the way that the family of origin influences the process of socialization (i.e., Rice & Mulkeen, 1995), most studies indicate a significant influence of the family of origin on adolescents' relationships. This is especially important for college students, who are often confronted with a new environment in college in which they must construct a new social support network upon beginning school. New relationships can also contribute to the perception of social support, which can impact students' mental health.

The reported literature should be considered in the context of its limitations. Specifically, most studies utilized a cross-sectional design, which limited inferences regarding causality. Furthermore, the sample had limited generalizability to the population overall, with a mostly homogenous, white sample. However, results from these studies support the relationship between the quality of family relationships and the quality of other relationships, primarily with peers and significant others (e.g., Green & King, 2009; Mounts et al., 2006; Robinson et al., 1995).

### **Influence of Social Support on Students Mental Health**

Social support has been recognized as a factor influencing mental health and well-being among the general population (Thoits, 2011). Researchers studying social support among college student populations often associate it with mental health (e.g., Hefner & Eisenberg, 2009), specifically depression. Social support has been conceptualized as multidimensional stemming from family, peer, teacher, and significant other relationships (Reuger et al., 2016). The family can influence social support in two ways: directly through the family's support of individual family members and indirectly through teaching and modeling social behavior that influences members' subsequent ability to build interpersonal relationships with others.

To understand social support, it is important to gain a basic understanding of how college students build their support networks. Hays and Oxley (1986) conducted a study examining how college students build their social networks over time. Results from self-report measures supported a gradual, systematic increase in the depth and breadth of students' social networks as their relationships with others progressed. Specifically, the intimacy level of networks was consistently and positively related to the amount of emotional support provided by the network. The amount of conflict in the network also increased over time, which was significantly and positively related to poor psychological well-being and significantly and negatively related to college adaptation. Furthermore, the number of fellow students identified by participants in their social networks was the variable most strongly and positively related to college adaptation. Based on this study, students seem to build their social network progressively, with levels of intimacy influencing the amount of support that students perceive from their social network.

Conflict in the social network may also directly influence negative mental health outcomes.

As students continue to build their social network, the degree and nature of social support they experience can positively and negatively influence their mental health. Hefner and Eisenberg (2009) conducted one of the first large-scale studies examining the influence of social support on college students' mental health. Utilizing a variety of parametric and nonparametric analyses, the researchers found that demographic variables such as minority ethnicity, international status, and low socioeconomic status put students at greater risk of social isolation. Furthermore, low levels of social support were significantly associated with measures of mental health symptoms, with the strongest relationship to measures of depression. Higher perceived quality of social support was strongly associated with lower likelihood of depression, anxiety, suicidality, and eating disorder, regardless of the frequency of social contacts and other individual characteristics. Results support the tenets of the General Benefits model of social support in that they additionally support the importance of social support in relation to college students' mental health.

Social support may also influence students differentially according to demographic factors. Farrell and Langreher (2017) explored the relationships among perceived stress, social support, depression, and protective factors against suicide in a group of ethnically diverse students. Hierarchical regressions revealed that college students who reported higher levels of perceived stress also reported more depressive symptoms and were less likely to engage in protective behaviors against suicide. Across all students, high levels of perceived social support were effective in buffering the

influence of stress, while low levels of support led to increased vulnerability to stress. Among ethnically diverse students, both high and low levels of social support mediated the relationship between stress and depression, whereas the relationship between these variables was not indicated among white students. It appears that social support may be a more salient factor for buffering the effects of stress among ethnically diverse students compared to white students.

Similarly, cultural orientation can serve as a moderator for social support and mental health. Shelton, Wang, and Zhu (2017) examined the impact of social support among students identifying with different cultural orientations. After controlling for demographic variables, the researchers found that low levels of perceived social support significantly predicted mental health indicators of depressive symptoms, symptoms of anxiety, stress, and life satisfaction. Conversely, higher levels of social support predicted better mental health levels, including fewer depressive and anxiety symptoms, lower stress levels, and higher satisfaction with life. Additionally, an independent cultural orientation (i.e., individualistic cultural values) moderated the relationship between social support and depression, while an interdependent cultural orientation (i.e., collectivist cultural values) moderated the effect of social support on anxiety, stress, and life satisfaction. Cultural orientation may, thus, differentially influence the way that social support moderates mental health outcomes among students.

Although the body of literature outline here provides support for the relationship between social support and student mental health, limitations of the studies should be considered. Primary limitations include homogenous samples (i.e., one institution) limiting generalizability, cross-sectional design limiting causality, and self-report, which

may have limited reliability and response bias. Despite these limitations, the studies in this section offer useful information regarding the importance of social support among college students is supported by studies identifying its relationship to mental health. Social support seems to provide a buffer for students who are at risk of experiencing mental health difficulties while also encouraging positive mental health (e.g., Hefner & Eisenberg, 2009). Social support may also affect students differently depending on individual factors, including ethnicity (i.e., Farrell & Langreher, 2017) and cultural orientation (i.e., Shelton et al., 2017). A probable relationship emerges between the findings of studies examining the influence of family functioning on students' ability to build interpersonal relationships, the influence of interpersonal relationship building on social support network building, and the importance of social support to students' mental health. Specifically, students who receive more support from their family and who learn socially competent behaviors are likely to benefit from more supportive social networks and better mental health.

### **Influence of Family Functioning on Mental Health**

Past and current family functioning may directly influence college students' mental health. From 2013 to 2017, the family was identified by college counselors as the fifth most prominent presenting concern among a large sample of college counseling centers (Center for Collegiate Mental Health, 2018). A significant body of research directly surveying college students supports the notion that students' mental health continues to be influenced by family functioning after they leave home to attend college. Much of the research has been focused on the influence of family functioning on

depression in college. A review of this research is germane to understanding the significance of family functioning on students' mental health.

Abuse in the family of origin can have a significant impact on the mental health of college students. Brack, Brack, Charbonneau, and Hill (2002) analyzed the relationships between family of origin characteristics and clinical symptomatology among clients in a college counseling center. Over three-quarters of participants reported experiencing some form of emotional abuse in their family of origin, while one quarter reported experiencing sexual abuse in their family of origin. Multiple regression analyses indicated that childhood emotional abuse was a significant predictor of depressive symptoms and adulthood emotional abuse among students. The abuse variables also explained a significant portion of the variance in clinical symptomatology. The findings indicate that students seeking counseling in this study reported a history of abuse in their family of origin that significantly influenced their mental health.

Along with abuse, family conflict and parent-child dependency can influence students' mental health. Hoffman and Weiss (1987) explored the influence of psychological separation, parent conflict, and perceptions of parent symptomatology on college students' presenting problems. The researchers found that college students were adversely affected by conflictual family relationships while attending school. This finding was supported by multiple regression analysis, indicating that interpersonal conflict in the family predicted intrapersonal distress among the student members of those families. The analyses also yielded a significant relationship between conflictual dependence of the student participants on one or both parents and student-reported emotional problems while in college. Finally, there was a significant relationship found



between inter-parent conflict and student presenting problems. Results of this research clearly support the notion that conflict in the family of origin can follow the student to school in the form of intrapersonal distress and emotional problems.

Family functioning may influence students differently based on their gender. Johnson (1993) examined the association between family relationships and symptomatology in a sample of students from one college. Results from correlations and multiple regression analysis indicated that among female participants, close family relationships were inversely associated with symptomatology, while distant family relationships were positively associated with elevated levels of symptomatology. Among male participants, there was no relationship between family relationships and symptomatology. As with social support, it appears that perception of closeness among family relationships may buffer or increase the risk of mental health problems among female students.

Along with influencing the risk of mental health difficulties, family functioning can contribute to increased feelings of well-being and can buffer the impact of trauma. Uruk, Sayger, and Cogdal (2007) examined the influence of family cohesion and adaptability on college students' trauma symptoms and psychological well-being, giving attention to gender and ethnicity. Hierarchical regression analyses suggested that gender and ethnicity did not significantly contribute to explaining trauma symptoms and psychological well-being. However, family cohesion and adaptability measured by the FACES were significantly positively associated with psychological well-being and significantly inversely related to symptoms of trauma. On the basis of these findings, it

appears that family functioning can have a significant positive influence on college students' general mental health along with buffering symptoms of trauma.

A larger body of research supports the relationship between family functioning and depression among college students. Lopez, Campbell, and Watkins (1989) conducted survey research with college students to examine the influence of family structure and psychological separation on the presence of depressive symptoms. Using a multivariate analysis of variance and bivariate correlations, the researchers found that depressed students experienced more conflictual exchanges with both parents, greater dissimilarity between their own values and their parent's values, and lower scores of parental cohesion and adaptability than non-depressed students. Furthermore, depressed students experienced more fear of separation than non-depressed students. The results support the conclusion that students experiencing interpersonal difficulties with their parents may be more likely to develop depressive symptoms in college.

The risk of depressive symptoms in emerging adulthood may be further influenced by specific processes among the larger family system. Ponappa, Bartle-Haring, Holowacz, and Ferriby (2016) used structural equation modeling to analyze the influence of triangulation, differential treatment from parents, and sibling warmth on depressive symptoms during college. The model indicated that when participants were triangulated into parental conflict, they perceived higher levels of parent differential treatment and lower levels of sibling warmth, which led to more depressive symptoms during emerging adulthood. Participants who were not triangulated perceived reduced levels of parental differential treatment, higher levels of sibling warmth, and reduced

depressive symptoms. The results offer further indication that relationships and functional patterns among the family may be related to symptoms of depression.

Broader constructs of family functioning such as perceived support can also have a significant influence on the development of depression and self-esteem in college. Li, Albert, and Dwelle (2014) used structural equation modeling to examine the power of parental and peer support in predicting depression and self-esteem among college students. Students and their parents participated in self-reporting these factors over four semesters. Results indicated that parental support was positively related to self-esteem and negatively related to depression in college students from the perspectives of students and their mothers. The researchers' findings also supported a significant positive relationship between peer support and self-esteem and a significant negative relationship between peer support and depression. From the students' perspective, peer support partially mediated the relationship between parental support and psychological adjustment. Results indicated that peer and parental support may differentially influence protective (i.e., self-esteem) and risk (i.e., depression) factors related to mental health among college students.

Along with self-esteem, family environments and social support can influence students' sense of self-efficacy in relation to depression. Reed, Ferraro, Lucier-Greer, and Barber (2015) used structural equation modeling to investigate the relationships among adverse family environments, social support, self-efficacy, and depressive symptoms. The researchers found significant relationships existing between adverse family environment and adult depressive symptoms, which was partially mediated by self-efficacy. They also found that social support mediated the relationship between adverse

environment on self-efficacy and depressive symptoms. Their findings generally suggest that self-efficacy and perceived social support can mediate the impact of negative family environments on developing depression among college students.

Other researchers have attempted to trace the influence of parental support on depression over time. Needham (2008) utilized latent growth curve analysis to explore the relationships among symptoms of depression and parental support during the transition from adolescence to young adulthood. Participants were interviewed as adolescents and then six to seven years later. Results clearly supported the notion that parental support influences depression, such that higher levels of parental support in adolescence were associated with lower initial levels of depressive symptoms. Participants with lower initial levels of parental support ended the study with higher levels of depressive symptomatology than participants with greater initial parental support, while adolescents who began the study with higher levels of depressive symptoms reported less parental support during adolescence and at the end of the study. The results indicate the significance of parental social support as a protective factor regarding depression during the transition from adolescence to adulthood.

Family functioning may also influence the depressive symptoms of adolescents through early transitional events. Wickrama, Conger, Lopez, and Jung (2008) followed a cohort of rural youth from early to middle adolescence to explore the influence of characteristics of the family of origin on adverse mental health trajectories. Latent growth curve analysis and structural equation modeling indicated that family of origin adversity exerted a persistent influence on the mental health of adolescents through trajectories of depressive symptoms and stressful social pathways. Family socioeconomic status

influenced depressive symptoms, while early transition events (e.g., teenage pregnancies, leaving the parental home earlier than normal, severing relationships with parents, entering into early cohabitation or marriage) led to failures in young adult social attainment, thus leading to depressive symptoms. Mutually reinforcing reciprocal processes also existed between depressive symptoms and stressful social pathways. That is, changes in depressive symptoms have long-term social consequences over the lifespan, which can result in extenuating symptoms of mental health. These findings suggest that family transitions can lead to difficulty in attaining social milestones, which reinforces depression in a reciprocal manner.

Primary limitations of studies in this body of research include cross-sectional designs limiting inferences of causality, homogenous samples limiting generalizability, and the use of self-report data which may result in response bias or error. The two longitudinal studies were also limited by homogenous samples and a potential lack of comprehensiveness regarding the variables considered in each study. Even with these limitations, results from the studies reviewed in this section inform us that both past (i.e., Brack et al., 2002, Hoffman & Weiss, 1987, Johnson, 1993, Reed et al., 2015) and current (i.e., Ponappa et al., 2016) family processes can influence the potential for mental health symptoms in adolescence and emerging adulthood. Conversely, family functioning may also serve as a buffer to symptomatology (i.e., Johnson, 1993) and symptoms of trauma (Uruk et al. 2007). More importantly, family functioning seems to influence children's mental health over time and into emerging adulthood (i.e., Needham, 2008; Wickrama et al., 2008). Factors influencing the emergence of mental health problems may be particularly important for college students due to the stressors inherent in the

college environment, which can lead to increased vulnerability to symptoms of mental health problems. The prevalence of family concerns among college students (Center for Collegiate Mental Health, 2018) and the impact that family functioning can have on college students' psychological and emotional functioning suggest that researchers and practitioners consider the potential impact of students' family system on their mental health.

### **Chapter Two Summary**

As indicated in the literature reviewed in this chapter, family functioning influences a multitude of factors pertaining to college student development, including social competence, social support, and mental health. The importance of building interpersonal relationships and supportive social networks in college is supported by this body of research. Families influence students' mental health directly through the provision of social support and indirectly through modeling social behavior. Family functioning can also directly influence college students' mental health by facilitating well-being or potential psychopathology. Although support exists for the relationship between family functioning and mental health (e.g., Brack et al., 2002; Hoffman & Weiss, 1987; Johnson, 1993), social behavior (e.g., Robinson et al., 1995), and social support related to mental health (e.g., Hefner & Eisenberg, 2009), these variables have not been examined together in a single model. Thus, the model proposed in the subsequent chapters incorporates the potential relationship among family structure, social competence, social support, and mental health among college students.

## **CHAPTER THREE**

### **METHODOLOGY**

The purpose of this study was to examine the relationship between family functioning, social competence, social support, and mental health among a sample of undergraduate students across the United States using survey research. A primary purpose of survey research is to make inferences from a sample to a population (Fowler, 2013). Advantages of survey research include the economy of the design, potential for rapid turnaround of results, and ability to make inferences to a larger population. The survey utilized in this study collected cross-sectional data and was administered through web questionnaires utilizing the Qualtrics online survey program.

#### **Sampling Procedures**

The population in this study was undergraduate students attending four-year institutions of higher education in the United States. The National Center for Education Statistics estimates that 13.3 million students are attending four-year institutions during the fall of 2018 (U.S. Department of Education, 2018). Multistage sampling, or clustering, was utilized to obtain the participant sample. Clusters consisted of randomly selected institutions of higher education grouped according to Carnegie Size & Setting classification (Indiana University Center for Postsecondary Research, 2015). Specifically, institutions were chosen based on their status of primarily and highly residential, indicating that at least 25% of students lived in college owned-operated or college-affiliated housing, and at least 50% of students attended full time. Residential institutions

were chosen based on the implication that the majority of students lived independently from their family of origin, potentially highlighting the impact of family functioning on social competence and social support among the participants.

Classifications of institutions utilized in this study include: (a) four-year, small, primarily residential and highly residential (i.e., between 1,000 and 2,999 students), (b) four-year, medium, primarily residential and highly residential (i.e., between 3,000 and 9,999 students), and (c) four-year, large, primarily residential and highly residential (i.e., over 10,000 students). A fourth category, four-year, very small, primarily residential and highly residential institutions, was excluded from the study based on lack of response to requests for participation. According to data provided by the Integrated Postsecondary Education Data System (National Center for Education Statistics, 2017), the total population of institutions fitting the three included categories was 975.

The procedure for selecting the sample consisted of several steps. First, a database was created using the Integrated Postsecondary Education Data System (National Center for Education Statistics, 2017) consisting of all institutions fitting the selected criteria of the study. Stratification was used to categorize institutions from the overall population into stratum according to Carnegie size and setting classifications (Indiana University Center for Postsecondary Research, 2015). To obtain a representative sample of institutions across the United States, simple random sampling was used to select institutions within each stratum. The researcher contacted each institutions' registrar by email regarding the availability of undergraduate student directory information, including student name, year (i.e., freshman, sophomore, junior, senior), and email address. Institutions that did not make this information publicly available or provided the



information at a monetary cost were removed from the study, while institutions permitting the distribution of this information were included.

The researcher continued contacting registrars until directories were gathered from 18 institutions. This number was chosen based on the notion that a large sample of participants would be collected from each institution. Furthermore, a sample size of  $n = 18$  institutions provides a number that can be reasonably divided to match the size and setting proportions of the overall population that is comprised of 49% small, 32% medium, and 19% large institutions. Accordingly, the researcher gathered directory information from nine small institutions, six medium institutions, and three large institutions. Based on a priori power analysis for structural equation models with an anticipated small effect size, four latent variables, 12 observed variables, and a probability level of  $\alpha = .05$  (Soper, 2018), a minimum sample size of 1,454 was recommended to detect a small effect.

Based on an expected response rate of 15%, 10,645 participants were invited to complete the study. Oversampling was also utilized with small institutions to achieve  $n = 200$ , which represents the minimum sample size to provide enough individuals within each stratum to run a factor analysis of any of the measures included in the study. To represent each stratum proportionally, the target sample for each stratum was indicated by the overall proportion of students attending each size of institution, resulting in the following target sample sizes: 1,995 for small institutions (13.3%); 2,720 for medium institutions (27.2%); and 5,930 for large institutions (55.7%). An even number of participants was recruited from each institution based on the target sample size and the

number of institutions in each stratum (e.g., 222 participants recruited from each small institution).

### **Data Collection**

Data were collected using the Qualtrics online survey program and followed the tailored design method for web and mobile questionnaires (Dillman et al., 2014). After the sample for each institution was obtained, an overall sample for each stratum was created using simple random sampling from each institution. The names of participants and contact data from each stratum were then uploaded into the Qualtrics system. Using the Qualtrics distribution function, potential participants were sent an initial email inviting them to complete the study. Embedded in the email was a brief description of the survey, a request to complete the survey, a link to complete the survey, a link to be removed from the survey, a confidentiality statement, and the researcher's contact information. All emails were personalized with the potential participant's first name.

Upon clicking the URL link located in the Qualtrics email, participants were directed to the informed consent portion of the survey. After reading the informed consent, participants indicated whether or not they agreed to complete the survey. Participants who agreed to complete the survey were directed to the beginning of the survey on the next page. Participants were asked to complete instruments related to family functioning, social competence, social support, and mental health. They were also asked to complete a brief demographics form. All participants' responses remained anonymous, with the only potential identifying information being their institution.

Those participants who decided to participate in the study were automatically removed by Qualtrics from the email list following completion of the survey. Potential

participants who did not complete the survey were sent an email reminder after two weeks inviting them to complete the study. A third and final reminder was sent after another two weeks to participants who had not yet completed the survey. The researcher utilized an incentive for this study by offering a certificate of completion following the end of the study. Participants who agreed to the incentive were emailed a certificate of completion created and signed by the researcher one month after the study was concluded.

## **Instrumentation**

### **Informed Consent Form**

An informed consent form was provided to potential participants at the beginning of the online survey. The informed consent form outlined the primary aspects of the study and rights of the participant including the purpose of the study, the procedure that the participant was asked to follow, any potential discomforts and risks of participation, the approximate duration of the survey, a statement of confidentiality, a statement of voluntary participation, potential incentives and benefits for participation, and procedures for terminating participation. Potential participants were also provided with the contact information of the researcher and the institutional review board should they wish to voice any concerns. Following the presentation of the informed consent, participants were asked to agree or disagree to complete the survey.

### **Demographics Form**

Participants were asked to complete a brief demographics form regarding their age, gender, year (i.e., freshman, sophomore, junior, senior), race/ethnicity, and the name of their institution. This data was used to indicate the degree to which the sample from

each institution was representative of the institution's overall demographic characteristics. Furthermore, demographic information was used to compare levels of family functioning, social competence, social support, and mental health across gender, year, race/ethnicity, institution, and size and setting classification.

### **Family Adaptability and Cohesion Evaluation Scale-IV**

Family functioning was measured using the Family Adaptability and Cohesion Evaluation Scale IV (FACES-IV; Olson, 2011). The FACES-IV is composed of 42 items measuring dimensions of family cohesion and adaptability across six subscales and uses a five-category response format ranging from 1 = *strongly disagree* to 5 = *strongly agree*. Two subscales assess balanced aspects of cohesion and flexibility, and four subscales assess unbalanced aspects including disengaged and enmeshed (cohesion) and rigid and chaotic (flexibility). Interpretation of the FACES-IV yields a Circumplex total ratio figure, which indicates a family's balanced and unbalanced characteristics in a single score.

The FACES-IV has demonstrated good internal consistency ( $\alpha = .77-.89$ ) across all scales (Olson, 2011), although the enmeshment scale demonstrated less than acceptable internal reliability ( $\alpha = .65$ ) in one study (Marscc & Alderfer, 2011). Construct validity of the FACES-IV has been supported by strong correlations ( $r = .89-.99$ ) with other measures of family functioning except for the enmeshed and rigid scales, which displayed only small correlations (Olson, 2011). Construct validity has also been demonstrated in the results of confirmatory factor analyses which supported the six-subscale model of the FACES-IV (Olson, 2011). The FACES-IV has demonstrated criterion validity by accurately identifying problematic families among a proportion of

presented cases (Marsac & Alderfer, 2011; Olson, 2011). In this study, the FACES demonstrated acceptable to good reliability for the Cohesion ( $\alpha = .87$ ), Flexibility ( $\alpha = .79$ ), Disengaged ( $\alpha = .81$ ), and Chaotic ( $\alpha = .82$ ) subscales. However, as in other studies, the Enmeshed subscale demonstrated poor reliability ( $\alpha = .54$ ) in this study, while the Rigid subscale also demonstrated suboptimal reliability ( $\alpha = .68$ ).

### **Texas Social Behavior Inventory Form A (TSBI)**

Social competence was measured using the Texas Social Behavior Inventory Form A (TSBI; Helmreich & Stapp, 1974). The TSBI Form A is composed of 16 items measuring self-esteem and social competence and uses a five-category response format ranging from 1 = *not at all characteristic of me* to 5 = *very much characteristic of me*. Both short form versions of the TSBI have demonstrated strong reliability ( $\alpha = .85-.88$ ). Criterion validity has been demonstrated through the measure's detection of significant differences between females who experienced child abuse and those who did not (Parker & Parker, 1991). Convergent validity has been supported in the measure's demonstrated ability to predict interpersonal attraction (Kimble & Helmreich, 1972), and discriminant validity has been supported through studies that show the TSBI is not related to intelligence or social desirability (Helmreich & Stapp, 1974). In this study, the TSBI demonstrated good reliability,  $\alpha = .87$ .

### **Multidimensional Scale of Perceived Social Support (MSPSS)**

Social support was measured using the Multidimensional Scale of Perceived Social Support (MSPSS; Zimet, Dahlem, Zimet, & Farley, 1988). The MSPSS is composed of 12 items measuring the perceived adequacy of support along three subscales including family, friends, and significant others, and the measure uses a seven-category

response format ranging from 1 = *very strongly disagree* to 7 = *very strongly agree*. Internal consistency has been adequately demonstrated for the MSPSS, with coefficient alphas ranging from  $\alpha = .81$  to  $.98$  for individual subscales and from  $\alpha = .84$  to  $.92$  for the overall scale (Zimet, Powell, Farley, Werkman, & Berkoff, 1990). Support for the validity of the MSPSS has been provided by exploratory and confirmatory factor analyses supporting a three-factor model (Zimet et al., 1990). Concurrent validity has been established with other measures of social support, and discriminant validity has been supported by the MSPSS's ability to distinguish between groups of students and inpatient adolescents (Zimet et al., 1990). Construct validity has also been supported by minimal associations between the MSPSS and social desirability and a negative association between the MSPSS and depression (Kazarian & McCabe, 1991). In this study, the MSPSS demonstrated excellent overall reliability ( $\alpha = .92$ ) as well as high reliability coefficients for the Significant Other ( $\alpha = .95$ ), Family ( $\alpha = .92$ ), and Friends ( $\alpha = .93$ ) subscales.

### **Mental Health Continuum-Short Form (MHC-SF)**

Well-being was measured using the Mental Health Continuum-Short Form (MHC-SF; Keyes, 2005). The MHC-SF consists of 14 items measuring emotional, psychological, and social well-being, and uses a six-category response option measuring the frequency with which respondents experienced a symptom over the past month ranging from 1 = *never* to 6 = *every day*. Good internal consistency ( $\alpha = .89$ ) has been demonstrated for the overall scale of the MHC-SF, while subscale reliabilities range from  $.74$  to  $.83$ . A three-factor structure has been supported by confirmatory factor analyses among college students (Robitschek & Keyes, 2009) and across cultures (Joshani, 2009).

Wissing, Khumalo, Lamers, 2013). In this study, the MHC-SF demonstrated excellent overall reliability ( $\alpha = .94$ ) as well as high reliability coefficients for the Emotional ( $\alpha = .9$ ), Social ( $\alpha = .85$ ), and Psychological ( $\alpha = .87$ ) subscales.

### **Depression, Anxiety, and Stress Scales-21 (DASS-21)**

Symptoms of psychopathology were measured using the Depression, Anxiety, and Stress Scales-21 (DASS-21; Lovibond & Lovibond, 1995). The DASS-21 is composed of 21 items measuring multiple dimensions of depression, anxiety, and stress, and uses a four-category response option ranging from 0 = *did not apply to me at all* to 3 = *applied to me very much, or most of the time* to rate the extent each item has applied to the respondent over the past week. Using data collected from undergraduate students, Kia-Keating and colleagues (2017) modified the wording on some of the items to be more relevant to U.S. college students' experiences. Among their sample, internal consistency ranged from  $\alpha = .96$  for the total score and  $\alpha = .94$  to  $.89$  for subscale scores. Although debate exists around the factor structure for the DASS-21, factor analysis with a sample of college students has supported a bi-factor model with three orthogonal factors of depression, anxiety, and stress, suggesting that both general and specific factors impacted the items (Kia-Keating et al., 2017). The results supported DASS-21 as a robust measure with strong psychometric properties when used with college students. In the current study the DASS-21 demonstrated good reliability overall ( $\alpha = .94$ ), as well as good reliability coefficients for the Depression ( $\alpha = .92$ ), Anxiety ( $\alpha = .84$ ), and Stress ( $\alpha = .85$ ) subscales individually.

### **Validity-Check Questions**

Two questions were embedded in the overall survey to check the validity of participants' responses. One question each was included at the end of the TSBI and the DASS-21, respectively. The questions asked for participants to select a specific response (i.e., "For this item, please select...") to ensure that they were reading each question and not randomly selecting their answers.

### **Research Questions and Hypotheses**

**Research Questions.** The study sought to answer the following four research questions:

1. How does family functioning relate to social competence, social support, and mental health among college students?
2. Does social competence mediate the relationship between family functioning and social support among college students?
3. Does social support mediate the relationship between family functioning and mental health among college students?
4. Do participants' family functioning, social competence, social support, and mental health differ according to demographic and institutional characteristics?

**Hypotheses.** The study sought to test the following six hypotheses:

Hypothesis 1: Balanced family functioning will predict higher social competence among students.

Hypothesis 2: Balanced family functioning will predict higher levels of perceived social support among students.



Hypothesis 3: Balanced family functioning will predict greater levels of well-being and lower levels of psychological symptoms.

Hypothesis 4: Higher levels of perceived social support will predict greater levels of mental well-being and lower levels of psychological symptoms.

Hypothesis 5: The relationship between family functioning and perceived social support will be mediated by social competence.

Hypothesis 6: The relationship between family functioning and mental health will be mediated by perceived social support.

### **Data Analysis**

Following the completion of data collection, the researcher converted survey data from the Qualtrics program into an SPSS file. Utilizing SPSS Statistics for Windows Version 25, the researcher ran a descriptive analysis of the sample and reported the mean and standard deviation of each continuous variable. The researcher also utilized skewness and kurtosis analyses to determine the normality of the data, and that the data fit the assumptions for ANOVA and SEM. The researcher then utilized ANOVA statistics to explore differences between groups included in the sample, including comparisons among overall scores of the measures of interest between gender, year, and race/ethnicity. Any significant main effects for these variables were examined further with appropriate post hoc analysis to discover differences between the means of each variable across groups (e.g., social support across Carnegie size classification).

The researcher then created several structural equation models using the data generated from the study. Paths among variables were based on the research hypotheses. Structural equation modeling was chosen for its ability to test causal pathways based on

theory, explore the measurement error of psychometric instruments, and its ability to test the overall fit of the theoretical model (Byrne, 2016). Following the creation of the model, the researcher conducted confirmatory factor analyses (CFA) on each individual instrument included in the study to correct for measurement error. Modifications were made to each measure based on the results of the CFA until an acceptable fit was obtained for each measure. The final SEMs included the modified measurement model of each instrument.

### Proposed SEM Model

The resultant proposed structural equation model was as follows:

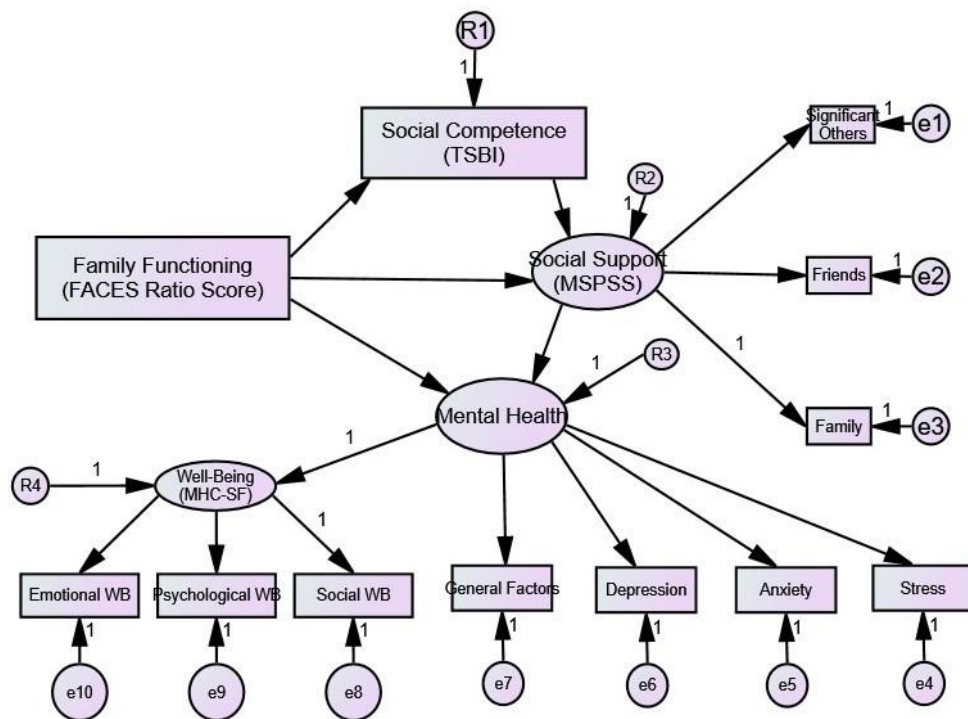

### Chapter Three Summary

Chapter three presents the proposed methodology of the study, including sampling procedures, data collection, and instrumentation. Chapter three ends by describing the

research questions and the researcher's hypotheses. Chapter four describes the results of the study.

## **CHAPTER FOUR**

### **FINDINGS**

Chapter four explores the findings of the research study according to each research question. The researcher first describes the participants in the study regarding their sociodemographic and academic characteristics. The researcher then discusses descriptive statistics of the sample, including measures of central tendency, standard deviation, and normality. Each research question is then discussed in terms of the analysis used to answer the question and the findings from each analysis.

#### **Participants**

Data collection occurred over an eight-week period lasting from early November to mid-December of 2018, during which 10,641 invitations were sent. Prior to data analyses, the data set was cleaned according to best practices (Osborne, 2013). From the overall sample of 1,359 responses (response rate of 12.77%), 633 were removed from the final data set utilizing listwise deletion for the following reasons: 13 participants indicated that they did not fit the qualifications of the study, 51 did not respond to the informed consent, 65 did not agree to the study, 431 were missing significant amounts of data (i.e., over 25% of the overall data or of a single measure), 102 failed the validity questions, and four were under the age of 18. This left an overall sample of  $n = 726$ , which was 6.82% of the overall sample.

Regarding gender, the sample identified as being primarily female ( $n = 514$ , 71%), followed by 26% of the sample ( $n = 193$ ) identifying as male. Three percent of the sample ( $n = 18$ ) identified as transgender/gender nonconforming, preferred not to disclose, or preferred to self-describe. The sample also identified as being primarily white ( $n = 599$ , 83%), followed by Hispanic or Latino ( $n = 42$ , 6%), Black or African American ( $n = 28$ , 4%), and Asian ( $n = 24$ , 3%). Less than 2% of participants identified as multiracial, American Indian or Alaskan Native, Native American or Other Pacific Islander, or self-described their ethnicity. In terms of student characteristics, most participants identified as Seniors ( $n = 199$ , 27%), followed by Freshmen ( $n = 189$ , 26%), Juniors ( $n = 151$ , 21%), Sophomores ( $n = 145$ , 20%), Graduate Students ( $n = 425$  3%), and Other ( $n = 16$ , 2%). In terms of Carnegie classification, most students attended Large institutions ( $n = 302$ , 42%), followed by Medium ( $n = 251$ , 35%) and Small ( $n = 173$ , 24%) institutions. The proportions of participants from each institution according to Carnegie Size is included in Table 1.

Table 1

*Proportions of Institutions*

Small	<i>n</i>	%	Medium	<i>n</i>	%	Large	<i>n</i>	%
S1	33	0.19	M1	29	0.12	L1	127	0.42
S2	5	0.03	M2	62	0.25	L2	87	0.29
S3	34	0.2	M3	29	0.12	L3	88	0.29
S4	25	0.14	M4	13	0.05	Total	302	
S5	27	0.16	M5	52	0.21			
S6	11	0.06	M6	66	0.26			
S7	8	0.05	Total	251				
S8	17	0.1						
S9	13	0.08						
Total	173							

**Score Conversions**

Prior to running statistical analyses, subscale and total scale scores were calculated for each measure based on instructions from each instrument. The FACES-IV also utilizes a Circumplex ratio score for research purposes, which was calculated (Olson, 2011). This score indicates the level of functional versus dysfunctional behavior that is perceived in the family system and is obtained by assessing the Balanced and Unbalanced score for each dimension. Ratio scores range from zero to 10, with one indicating an equal amount of balance and unbalance in the system. The majority of scores range from zero to two.

### **Weighting**

Cases were weighted prior to running analyses to match the population proportions indicated by the Carnegie size and setting classification (Indiana University Center for Postsecondary Research, 2015). Weights were created by examining the sample size according to each institution size classification (i.e., small, medium, large) and weighting them appropriately according to the desired sample size of 1,454 and proportions of 13.3% for small institutions, 27.2% for medium institutions, and 59.4% for large institutions.

### **Descriptive Statistics**

Descriptive statistics were utilized to examine the normality, mean, and standard deviation of participants' scores on the subscale and total scores of each measure. The findings are summarized in Table 2 according to each measure. FACES-IV total ratio scores for this sample indicated that the sample was slightly above the average score of two, thus indicating slightly more balanced family systems (Olson, 2011). TSBI total scores ( $M = 53.07$ ) were higher in this sample than the reference sample from Helmreich

and Stapp (1974), which reported a mean total score of 40.55 ( $SD = 8.95$ ), indicating that this sample reported higher levels of overall social competence. Mean total and subscale scores on the MSPSS were similar to those reported by Kazarian and McCabe (1991) for university students, Total = 5.81 ( $SD = .79$ ), Significant Other = 5.89 ( $SD = 1.21$ ), Family = 5.75 ( $SD = 1.08$ ), Friend = 5.84 ( $SD = .9$ ). Total and subscale scores on the MHC-SF among this sample were higher than a nationally representative sample of college students reported by Keyes et al. (2012), Total = 47.46 ( $SD = 12.32$ ), Emotional Well-Being = 11.34 ( $SD = 2.79$ ), Social Well-Being = 14 ( $SD = 5.45$ ), Psychological Well-Being = 22.14 ( $SD = 5.64$ ). This finding implies that the sample reported higher emotional, social, and psychological well-being than the reference group. Finally, DASS-21 scores were substantially higher among this sample than a sample of U.S. college students (Kia-Keating et al., 2017), Total = 14.1 ( $SD = 10.6$ ), Depression = 4.1 ( $SD = 4.3$ ), Anxiety = 3.9 ( $SD = 3.6$ ), Stress = 6 ( $SD = 4.1$ ). This finding implies that the sample was experiencing much higher levels of depression, anxiety, and stress than the reference group.

Table 2

*Descriptive Statistics from Continuous Measures*

Measure	Mean	Std. Deviation	Skewness	Kurtosis
FACES Total Ratio	2.23	.93	.34	-.01
Cohesion	28.14	5.12	-1.29	1.91
Flexibility	24.08	5.26	-.66	.13
Disengaged	16.82	5.14	.68	.19
Enmeshed	15.87	3.37	.53	.97
Rigid	19.82	4.48	.11	-.19
Chaotic	15.75	5.06	.74	.42
TSBI Total	53.07	10.45	-.24	-.36
MSPSS Mean Total	5.56	1.08	-1.08	1.29
Significant Others	5.61	1.46	-1.26	.98
Family	5.48	1.4	-1.18	.93

Friends	5.6	1.24	-1.11	1.33
MHC-SF Total	57.45	14.69	-.35	-.55
Emotional	13.48	3.28	-.69	-.03
Social	18.23	6.05	-.08	-.9
Psychological	25.73	6.72	-.51	-.49
DASS-21 Total	40.4	13.11	.75	.01
Depression	13.04	5.32	1	.24
Anxiety	12.24	4.59	1.05	.58
Stress	15.12	4.75	.41	-.47

### **Research Question #1**

The first research question explored the relationships between family functioning, social competence, social support, and mental health among college students. The primary research question was answered utilizing structural equation modeling. Structural equation models are composed of two submodels: (a) the measurement model, which defines the relationship between the underlying constructs and what they are intended to measure, and (b) the structural model, which defines the relationship among the unobserved (i.e., latent) variables (Byrne, 2016). Confirmatory factor analyses (CFA) are first used to confirm the model fit of each construct that is measured in the structural model prior to the overall SEM. The goal of CFA is to test the hypothesized model as well as potential alternative theoretical models of an instrument.

Several tests were utilized to evaluate the fit of each model, including the  $\chi^2$  test of model fit, the comparative fit index (CFI; Bentler, 1990), the Tucker-Lewis Index (TLI), and root mean square error of approximation (RMSEA). CFI and TLI values greater than .95 and RMSEA values less than .05 indicated good fit; CFI and TLI values between .90 and .95 and RMSEA values between .05 and .08 indicated adequate fit. As suggested by MacCallum, Browne, & Sugawara (1996), RMSEA values ranging from .08 to .1 were considered acceptable. The RMSEA value was considered most important for



each model based on suggestions from MacCallum and Austin (2000). CFAs were performed using SPSS AMOS Version 24 statistical package (Arbuckle, 2016)

### **Confirmatory Factor Analyses**

**FACES-IV.** A CFA utilizing Maximum likelihood estimation was conducted on the FACES-IV responses. Based on Olson (2011), a six-factor model was hypothesized, with intercorrelations between the Enmeshed, Cohesion, and Disengaged subscales (i.e., Cohesion), and intercorrelations between the Chaotic, Flexibility, and Rigid subscales (i.e., Flexibility; See Figure 1 in Appendix A). Although the CFI did not indicate a good fit, the RMSEA indicated an adequate fit. However, one of the standardized parameter estimates was out of bounds (i.e.,  $> 1$ ) indicating that the model was not acceptable. Therefore, a second model was tested that collapsed the intercorrelated Enmeshed, Cohesion, and Disengaged subscales into one factor and left the other three factors (i.e. Chaotic, Flexibility, Rigid) to be intercorrelated (See Figure 2 in Appendix A). This model presented similar fit statistics to the initial model and had no problematic parameter estimates. A third model tested the fit when each of the cohesion and flexibility subscales, respectively, were collapsed into two larger factors (See Figure 3 in Appendix A). This model was tested to discover if the oblique factors of family flexibility would fit into one factor as the cohesion factors did in Model 2. Fit statistics indicated that fit worsened in the third model compared to the first two. Thus, the researcher chose to utilize the second model for the FACES-IV. Table 3 presents the fit indices of each tested model.

Table 3

*Fit Statistics for Each of the Tested Models of the FACES-IV*

Model	$\chi^2$	<i>df</i>	CFI	TLI	RMSEA
Model 1	4860.68	813	.7	.68	.08
Model 2	4906.35	816	.7	.68	.08
Model 3	4906.35	816	.66	.64	.09

**TSBI.** A CFA utilizing Maximum likelihood estimation was conducted on the TSBI responses. A one-factor model was hypothesized according to Helmreich and Stapp (1974). The chi-square value was significant,  $\chi^2(104) = 805.66, p < .001$ . Although the CFI (.8) and the TLI (.77) did not indicate adequate fit, the RMSEA (.096) indicated an acceptable level of fit. Therefore, the TSBI was accepted as a one-factor model (See Figure 4 in Appendix A).

**MSPSS.** A CFA utilizing Maximum likelihood estimation was conducted on the MSPSS responses. A three-factor model was hypothesized based on the findings of Zimet et al. (1990). The chi-square value was significant,  $\chi^2(51) = 276.16, p < .001$ . The CFI = .97, the TLI = .96, and the RMSEA = .08, indicating good to adequate fit. Thus, the MSPSS was accepted as a three-factor model (See Figure 5 in Appendix A).

**MHC-SF.** A CFA utilizing Maximum likelihood estimation was conducted on the MHC-SF responses. The researcher tested a three-factor model based on the findings of Keyes (2005) and Joshanloo et al. (2013) (See Figure 6 in Appendix A). Although the CFI indicated adequate fit for this model, TLI and RMSEA indicated a poor fit. Modification indices were then examined to determine whether specification changes could improve the model. The researcher decided to correlate error six with errors seven and eight and justified this decision based on two rationales: (a) Each item was located in the same scale, and (b) each item asked similar questions, focusing on wellness in larger communities or society as a whole. Following the correlation of errors, the model

improved, with TLI and RMSEA values in the adequate range (See Figure 7 in Appendix A). Table 4 presents the fit indices of each tested model.

Table 4

*Fit Statistics for Each of the Tested Models of the MHC-SF*

Model	$\chi^2$	<i>df</i>	CFI	TLI	RMSEA
Model 1	654.14	74	.91	.89	.1
Model 2	440.26	72	.95	.93	.08

**DASS-21.** A CFA utilizing Maximum likelihood estimation was conducted on the DASS-21 responses. The first model supported by Lovibond and Lovibond (1995) indicated a three-factor model. The chi-square value was significant,  $\chi^2(186) = 1036.03$ ,  $p < .001$ . The CFI = .91, TLI = .9, and the RMSEA = .08 indicated an adequate fit for the model (See Figure 8 in Appendix A). A second model suggested by Kia-Keating et al. (2017) was utilized with a sample of college students and suggested a bi-factor model including the three subscales and a general factor for all of the items (See Figure 9 in Appendix A). This model would not converge with up to 2,000 iterations. Therefore, it was concluded that this model was not admissible.

**Structural Equation Model**

The structural model describes the relationships among the latent (i.e., unobserved) variables and specifies how the latent variables influence each other, whether directly or indirectly (Byrne, 2016). The hypothesized SEM was first edited to align with findings from the CFA results. Two primary models were utilized: the first model utilized the total ratio score from the FACES-IV. Olson (2011) suggested that the total ratio score was designed for research as it is linear and provides a singular score assessing balanced versus unbalanced functioning. The second primary model utilized the

FACES-IV scores according to the measurement model results for the FACES-IV described above. In this model, the FACES-IV was represented by an observed Cohesion score and a three-factor Flexibility score.

**FACES Total Ratio Score.** A SEM analysis was performed using SPSS AMOS Version 24 statistical package (Arbuckle, 2016). Maximum likelihood parameter estimation was utilized because the data met the requirement of normality. As noted in Table 6, the hypothesized model did not appear to be a good fit to the data (See Figure 1 in Appendix B). Thus, we examined modification indices to improve fit, which indicated correlations between errors three (i.e., Significant Other subscale) and five (i.e., Friend subscale) of the MSPSS as well as errors nine (i.e., Stress subscale) and 10 (i.e., Anxiety subscale) of the DASS-21. These modifications were justified based on the similarity of wording between the correlated subscales. Specifically, the significant other and friend subscales of the MSPSS utilized questions about a “special person” and a “friend”, respectively. The anxiety and stress subscales of the DASS-21 also asked questions about similar symptoms, such as “I had a lot of nervous energy” and “I experienced trembling or shaking”. Despite modifications, the model indicated a mediocre to adequate fit to the data (See Figure 2 in Appendix B). However, several of the standardized parameter estimates were out of bounds (i.e.,  $> 1$ ) and two residuals indicated a negative variance. Therefore, the model was considered not admissible.

A third model removed the hierarchical latent variable of Mental Health, thus implying that the MHC-SF and the DASS-21 were uncorrelated (See Figure 3 in Appendix B). Although fit indices indicated that the model had a mediocre to adequate fit, several of the standardized estimates were out of bounds. Furthermore, the model

contained one negative residual. Thus, this model was also considered not admissible. A fourth model removed paths predicting the MHC-SF and DASS-21 scores directly from FACES-IV total ratio scores (See Figure 4 in Appendix B). Thus, the FACES-IV total ratio scores only directly predicted TSBI and MSPSS scores. This model did not fit the data well. Based on the fit indices of the initial SEM and subsequent modifications of the model, there was no adequate solution for the model. Table 5 presents the fit indices of each model.

Table 5

*Fit Statistics for SEMs utilizing FACES Total Ratio Scores*

Model	$\chi^2$	<i>df</i>	CFI	TLI	RMSEA
Model 1	628.5	39	.88	.83	.14
Model 2	271.22	37	.95	.93	.09
Model 3	269.67	37	.95	.93	.09
Model 4	794.1	41	.84	.79	.16

**FACES Measurement Model.** A SEM analysis was then run for the fifth model, which utilized the FACES-IV scores as suggested by the measurement model (i.e., CFA), indicating uncorrelated factors of an observed cohesion total score and a three-factor latent variable representing the dimensions of flexibility (See Figure 5 in Appendix B). This model did not fit the data well, and modification indices suggested correlating the cohesion and flexibility factors, errors three and five, and errors nine and 10 to improve fit (See Figure 6 in Appendix B). Modifications improved the sixth model to have mediocre to adequate fit statistics. However, several of the standardized estimates were out of bounds. Thus, this model was also considered not admissible.

A seventh model removed the hierarchical mental health latent variable, indicating that MHC-SF and DASS-21 scores were uncorrelated (See Figure 7 in

Appendix B). Fit indices indicated that this model was not a good fit to the data. An eighth model removed direct paths predicting the MHC-SF and DASS-21 scores from FACES-IV cohesion and flexibility scores (See Figure 8 in Appendix B). Fit indices indicated that this model was not a good fit to the data. Based on the fit indices of the initial SEM and subsequent modifications of the model, there was no adequate solution for the model. Table 6 presents the fit indices of each model.

Table 6

*Fit Statistics for SEMs utilizing FACES based on Measurement Model*

Model	$\chi^2$	Df	CFI	TLI	RMSEA
Model 5	1093.1	67	.84	.78	.15
Model 6	423.14	66	.94	.92	.09
Model 7	901.8	66	.87	.82	.13
Model 8	1010.56	70	.85	.81	.14

Following the creation of each model, assumptions of normality were examined in each model. Assessment of outliers and univariate normality indicated that these assumptions of normality were met according to West, Finch, and Curran (1995), who considered values exceeding seven to indicate significant univariate kurtosis. However, following Bentler's (2005) suggestion, multivariate kurtosis was observed in each model as indicated by a critical ratio value over five. A critical assumption in SEM analyses and Amos in particular (Arbuckle, 2016) is that the data are multivariate normal (Byrne, 2016).

In order to address the presence of nonnormality in the data, a Satorra-Bentler Scaled Statistic was suggested (Satorra & Bentler, 1994). This statistic was utilized to provide a statistic that corrects the  $\chi^2$  value as well as the standard errors in a maximum likelihood statistic. Mplus Version 8.2 was utilized to conduct this analysis on the larger

measurement model of the MSPSS, which demonstrated significant kurtosis influencing the rest of the model. However, this model did not result in a good fit for the MSPSS,  $\chi^2(3) = 256.25$ ,  $p < .001$ , CFI = 1, TLI = 1, and the RMSEA = .66.

**Observed Model.** Due to the inability to find an adequate SEM model for the data, a final model was run assuming that all of the measures utilized in the study were observed (See Figure 9 in Appendix B). This new model is a path model rather than a SEM because all of the variables are represented as measured. The chi-square value was significant,  $\chi^2(3) = 499.34$ ,  $p < .001$ . The CFI = .64, TLI = -.2, and the RMSEA = .49 indicated a poor fit for the model. Thus, this model was not considered an acceptable representation of the data.

Despite the model not fitting the data well, there were observed relationships between each variable. FACES-IV total ratio scores were directly and positively related to TSBI total scores (standardized coefficient = .34), MSPSS mean total scores (standardized coefficient = .43), and MHC-SF total scores (standardized coefficient = .16). Furthermore, FACES-IV scores were directly, negatively related to the DASS-21 total scores (standardized coefficient = -.22). MSPSS scores also directly positively predicted MHC-SF scores (standardized coefficient = .51) and directly negatively predicted DASS-21 scores (standardized coefficient = -.3). Although paths were significant, small effect sizes were observed in the prediction of TSBI, MSPSS, and DASS-21 scores from FACES-IV total ratio score, as well as the prediction of DASS-21 scores from MSPSS scores (Cohen, 1988). FACES-IV total ratio score had less than a small effect in predicting MHC-SF scores. However, a medium effect size was observed in the prediction of MHC-SF scores from MSPSS scores.

## **Summary**

Research Question 1 was tested utilizing nine different models. The first four models assumed that the total ratio score of the FACES-IV was observed and predicted the other four variables. Models five through eight utilized the measurement model of the FACES-IV, which asserted a four-factor model with three oblique flexibility factors (i.e., flexibility, chaotic, rigid) and one overall factor representing cohesion. The final model utilized a path analysis in which all variables were measured. None of the models fit the data well, indicating that the overall model was not an adequate solution for the data.

### **Research Question #2 and #3**

The second research question explored whether social competence mediated the relationship between family functioning and social support among college students. The researcher utilized the path analysis to examine whether TSBI scores mediated the relationship between FACES-IV Total Ratio scores and MSPSS mean total scores. Although there was a significant indirect path, it demonstrated a less than small effect (standardized indirect coefficient = .09). The third research question explored whether social support mediated the relationship between family functioning and mental health among college students. MSPSS mean total scores did significantly mediate the relationship between FACES-IV Total Ratio scores and MHC-SF total scores (standardized indirect coefficient = .26). MSPSS mean total scores also significantly mediated the relationship between FACES-IV Total Ratio scores and DASS-21 scores (standardized indirect coefficient = -.16). The mediation effect of the MSPSS ranged from small for predicting the MHC-SF to less than small for predicting the DASS-21.

### **Research Question #4**



The fourth research question explored whether family functioning, social competence, social support, and mental health differed according to demographic and institutional characteristics. T-tests and one-way analyses of variance (ANOVA) were used to explore whether groups significantly differed on the measured variables based on categorical variables. A Bonferroni correction was utilized with the eight t-tests in order to correct for alpha slippage, resulting in an alpha level of .006. In order to account for small sample sizes prior to running comparisons for ethnicity, the researcher combined groups with less than 30 participants into an “Other” group, which included participants identifying as American Indian or Alaska Native, Multiracial, Native American or Other Pacific Islander, and Other.

### **Family Functioning**

A one-way ANOVA was used to determine if there were differences in family functioning between ethnicity. FACES ratio scores were not significantly different between different ethnicities,  $F(4, 1487) = 1.71, p = .15$ .

### **Social Competence**

A one-way ANOVA was used to determine if there were differences in social competence between institution size based on Carnegie classification. TSBI total scores were significantly different between students from different sized institutions,  $F(2, 1492) = 4.74, p = .009$ . TSBI total scores were highest among participants attending large institutions ( $M = 53.75, SD = 10.31$ ), followed by small institutions ( $M = 52.17, SD = 10.45$ ) and medium institutions ( $M = 52.01, SD = 10.66$ ). Because there was no violation of homogeneity of variances, as assessed by the Levene’s test ( $p = .79$ ), a Tukey post hoc analysis ( $\alpha = .05$ ) was conducted. The comparisons indicated that students from large

institutions were reported significantly higher TSBI total scores than students from medium institutions (1.74, 95% CI [.28, 3.2],  $p = .015$ ). The effect of this difference was represented by  $\eta^2 = .006$ , indicating a small effect size (Cohen, 1988). TSBI mean scores across institution size are presented in Table 7.

Table 7

*TSBI Mean Scores across Institution Size*

Institution Size	<i>M</i>	<i>SD</i>
Small	52.17	10.45
Medium	52.01	10.66
Large	53.75	10.31

A second one-way ANOVA was run to determine if there were significant differences in TSBI scores between class rank. TSBI total scores were significantly different between class rank,  $F(5, 1486) = 3.25, p = .006$ . Because there was violation of the assumption of normality as indicated by a significant Levene's statistic ( $p < .001$ ), a Games Howell post-hoc test was conducted. The comparisons indicated no significant differences between groups,  $p < .05$ .

An independent t-test was then run to determine differences in TSBI total scores based on age category, which categorized students into two groups based on a cutoff age of 25. Equal variances were not assumed as evidenced by a significant Levene's statistics ( $p = .027$ ). There were no significant differences in TSBI scores between nontraditional and traditional students,  $p > .006$ . A second independent t-test was run to determine differences in TSBI scores based on gender, which indicated that differences were not significant,  $p < .006$ .

### **Social Support**

Two one-way ANOVAs were run to determine if there were significant differences in MSPSS total scores based on categorical data. The first ANOVA was run to determine if there were significant differences in MSPSS total scores between class rank. The ANOVA model was not significant. A second one-way ANOVA was run to determine differences in social support across ethnicities. The one-way ANOVA indicated significant differences in perceived social support between ethnicities,  $F(4, 1487) = 4.96, p = .001$ . Because there was violation of the assumption of normality as indicated by a significant Levene's statistics ( $p < .001$ ), a Games Howell post-hoc test was conducted. The comparisons indicated no significant differences between groups,  $p < .05$ .

Two independent t-tests were also run to analyze differences on MSPSS total scores across gender and age category. The first t-test examining gender differences indicated that equal variances were assumed, as the Levene's statistic was non-significant ( $p = .75$ ). Females ( $M = 5.62, SD = 1.09$ ) reported significantly higher MSPSS total scores than males ( $M = 5.42, SD = .05$ ),  $t(1486) = -3.22, p = .001$ . The effect of this difference was represented by a Cohen's  $d = .19$ , indicating a less than small effect size (Cohen, 1988). The second t-test examining age category met the assumption for equality of variances as evidenced by a nonsignificant Levene's statistic ( $p = .72$ ). There were no significant differences found between the MSPSS total scores of traditional and nontraditional students,  $p < .006$ .

## **Mental Health**

**Mental wellness.** One-way ANOVAs were used to compare mental wellness scores on the MHC-SF total scores across ethnicity and class rank. The ANOVA was

significant, indicating differences between groups on MHC-SF total scores,  $F(4, 1487) = 2.58, p = .04$ . Because there was no violation of the assumption of normality as indicated by a nonsignificant Levene's statistic ( $p = .18$ ), a Tukey post-hoc test was conducted. The comparisons indicated no significant differences between groups,  $p < .05$ . The second ANOVA examining differences across class rank was significant, indicating that there were significant differences across groups,  $F(5, 1486) = 6.88, p < .001$ . Because there was no violation of the assumption of normality as indicated by a nonsignificant Levene's statistic ( $p = .256$ ), a Tukey post hoc test was conducted. Results indicated that Freshmen, Sophomores, and Seniors reported significantly higher MHC-SF total scores than Juniors. The effect of this difference was represented by  $\eta^2 = .023$ , indicating a medium effect size (Cohen, 1988). MHC-SF total scores across class rank are displayed in Table 8.

Table 8

*MHC-SF Total Scores across Class Rank*

Class Rank	<i>M</i>	<i>SD</i>
Freshman	58.64	14.74
Sophomore	59.17	14.08
Junior	54.49	14.76
Senior	58.01	14.92

Independent t-tests were then run to determine if there were significant differences in mental wellness across gender and age category. The first t-test examining differences across gender did not violate assumptions of equality of variances based on a nonsignificant Levene's statistic ( $p = .076$ ). The t-test indicated no significant difference in MHC-SF scores between gender,  $p < .006$ . The second t-test examining differences across age category did not violate equality of variance as indicated by a nonsignificant

Levene's statistic ( $p = .26$ ). The t-test indicated no significant difference in MHC-SF between nontraditional and traditional students.

**Mental health symptomatology.** Two one-way ANOVAs were run to determine if there were differences in DASS-21 total scores across ethnicity and class rank. The first ANOVA examining differences on DASS-21 scores among ethnicity was nonsignificant,  $F(4, 1487) = .88, p = .47$ . The second ANOVA examining differences across class was significant,  $F(5, 1486) = 3.85, p < .01$ . Because the assumption of normality was violated as indicated by a significant Levene's statistic ( $p = .01$ ), a Games-Howell follow up test was conducted ( $\alpha = .05$ ). Results of this test indicated that Freshmen and Juniors reported significantly higher DASS-21 total scores than Graduate students. Furthermore, Juniors reported significantly higher DASS-21 total scores than Seniors. The effect of this difference was represented by  $\eta^2 = .013$ , indicating a medium effect size (Cohen, 1988). DASS-21 total scores across class rank are displayed in Table 9.

Table 9

*DASS-21 Total Scores across Class Rank*

Class Rank	<i>M</i>	<i>SD</i>
Freshman	41.09	13.69
Junior	42.26	13.91
Senior	39.36	12.49
Graduate	36.07	10.68

Independent t-tests were then run to determine if there were significant differences in DASS-21 scores across gender and age category. In the first t-test examining differences between gender, Levene's test indicated that equality of variances was violated ( $p = .01$ ). The analysis indicated that Females ( $M = 41.18, SD = 13.19$ )

reported significantly higher DASS-21 total scores than Males ( $M = 37.6, SD = 12.02$ ),  $t(825.77) = -4.99, p < .001$ . The effect of this difference was represented by a Cohen's  $d = .28$ , indicating a small effect size (Cohen, 1988). The second t-test examining differences between age category indicated that the assumption of homogeneity of variances was met ( $p = .07$ ). Traditional students ( $M = 40.96, SD = 13.13$ ) reported significantly higher DASS-21 total scores than nontraditional students ( $M = 35.07, SD = 11.78$ ),  $t(1486) = 4.94, p < .001$ . The effect of this difference was represented by a Cohen's  $d = .47$ , indicating a small effect size (Cohen, 1988).

### Summary

Results from comparisons indicated that the gender and class rank evidenced the most differences across groups, namely, differences across MSPSS and DASS-21 scores for gender and differences across MHC-SF and DASS-21 scores for class rank. There were also differences in DASS-21 scores across age category and TSBI scores across institution size. There were no differences in any of the measures across ethnicity.

Differences found in instruments across categorical variables are displayed in Table 10.

Table 10

#### *Significant Differences Across Variables*

Measure	<i>Age Category</i>	<i>Gender</i>	<i>Ethnicity</i>	<i>Class Rank</i>	<i>Institution Size</i>
FACES-IV					
TSBI					*
MSPSS		*			
MHC-SF				*	
DASS-21	*	*		*	

\* Significant differences were found between groups

### Chapter Four Summary

Chapter four describes the results of the study in the context of each research question. Specifically, each statistical analysis utilized to answer the research questions is described as well as the results of these analyses. Chapter five discusses the research findings in the context of the literature review, as well as describing practical implications and recommendations for future research.

## **CHAPTER FIVE**

### **DISCUSSION**

Chapter five explores the implications of the research study according to the findings, the research questions, and the hypotheses. The researcher first describes the characteristics of the sample according to each instrument utilized in the study. The researcher then discusses the implications of the findings according to each of the research questions and their hypotheses. Following a discussion of the overall findings, the researcher explores potential practical implications and recommendations for future researchers. Limitations of the findings are then discussed, and a summary of the findings concludes the dissertation.

#### **Discussion of Findings**

Overall, participants in this study indicated that their families were functioning in ways that were more balanced than unbalanced (Olson, 2011), implying that most participants reported healthy family functioning. Healthy family functioning has been related to a range of positive outcomes for college students, including social competence (i.e., Bell et al., 1985; Holt, 2014), quality relationships with peers (i.e., Dekovic & Meeus, 1997; Mounts et al., 2006), lower levels of mental health symptomatology (e.g., Johnson, 1993; Ponappa et al., 2016), increased feelings of well-being (Uruk et al., 2007), and increased self-esteem (Li et al., 2014). Participants also described themselves as slightly to fairly socially competent, which may be in response to the second separation-



individuation phase that occurs when students attend college. This phase often requires students to begin to build and sustain mature interpersonal relationships with others (Eichler, 2006), such that students attempt to learn new social skills to navigate the college milieu.

Potentially utilizing their social competence, participants also reported mild to strong agreement that they experienced social support from family, friends, and significant others. Along with family functioning, perceived social support has been related to positive outcomes among college students, including lower levels of mental health symptoms (i.e., Farrell & Langreher, 2017; Hefner & Eisenberg, 2009) and higher life satisfaction (Shelton et al., 2017). In terms of mental health, participants reported experiencing symptoms of well-being two or three times a week over the past month. Conversely, participants reported experiencing symptoms of depression, anxiety, and stress some or a good part of the time over the past week. Results from the DASS-21 seem to reflect recent increases in mental health symptomology across the college population (i.e., Xiao et al., 2017). Furthermore, these results seem to indicate that college students report a spectrum of mental health experiences, from feelings of well-being to mental health symptomatology.

**Research Question #1: How does family functioning relate to social competence, social support, and mental health among college students?**

This section reviews the findings of the study regarding research question one, specifically, the measurement model of each instrument and the structural equation model (SEM) testing the relationships among variables in the study.

**Measurement model.** The measurement model was explored by conducting CFA on each of the measures utilized in the study. Results from each CFA indicated whether or not the theoretical foundation of the measure fit well with the sample of college students. Internal reliability of each measure also contributed to its ability to measure each construct. Results are discussed in light of these primary factors related to each measure's validity.

Factor analytic results from the FACES-IV indicated that the original six-factor (i.e., cohesion, flexibility, disengaged, enmeshed, rigid, chaotic) model posited by Olson (2011) may not be a good fit for the college student population. Instead, the fit indices suggested that college students family functioning may be better characterized by a four-factor model, with one factor representing overall characteristics of cohesion (i.e., balanced cohesion, enmeshment, disengagement) and three separate but correlated factors representing chaotic, flexible, and rigid family functioning. It seems that college students may experience family flexibility in a more idiosyncratic way than family cohesion. A second consideration is that the FACES-IV may not be a reliable measure of family functioning among college students. Internal reliability indicated that two subscales (i.e., enmeshed, rigid) demonstrated suboptimal to poor reliability. These low reliability scores likely influenced the validity of the overall measure, thus resulting in a poor fit of the original model and suggesting that the FACES-IV may not be a reliable measure for measuring family functioning among college students.

Conversely, CFA results from the TSBI, MSPSS, MHC-SF, and DASS-21 demonstrated adequate fit, indicating that the theoretical foundations of these measures seem to be representative of college students' experiences of each measured construct.

These results may not be surprising, as many of these measures (i.e., TSBI, MSPSS) were normed on college students. Each of these measures also demonstrated high internal reliability, which contributed to their overall validity. Therefore, these measures can be considered adequate to measure social competence, social support, well-being, and symptoms of depression, anxiety, and stress among college students.

**Structural equation model.** The SEM was based on two primary elements: (a) the measurement model, guided by the results of the CFAs and (b) the a priori hypothesis describing the relationship among variables in the study. Neither the results utilizing the FACES-IV total ratio score as a measured variable nor the results utilizing the model of the FACES-IV suggested by the CFA indicated a good fit, even when justified modifications were made to the model. Two errors continued to arise when testing the model, the first indicating that parameters were out of bounds regarding relationships between variables, and the second indicating that the model did not fit the data well. One factor that could have significantly contributed to these errors was an erroneous initial assumption of multivariate normality. While each of the individual measures displayed univariate normality, the overall model did not meet assumptions of multivariate normality, which is a critical assumption of SEM analyses (Byrne, 2016).

Acknowledging the model's limitations, there nonetheless were observed relationships between variables in the path analysis. Each relationship was interpreted in light of their effect size, which was defined by Cohen (1988) as the “degree to which the phenomenon is present in the population or the degree to which the null hypothesis is false” (pp. 9-10). Effect size is often used to convey the practical significance or importance of an effect (Kirk, 1996). Cohen’s (1988) “rules of thumb” for effect size

were used based on the theoretical nature of the research questions in this study (Cohen, 1988). Effect size in structural equation modeling is gathered from the coefficients of determination (i.e.,  $R^2$ ), which are indicated by the standardized regression coefficient displayed on each relationship in the model.

In terms of effect sizes, small positive effects were observed between family functioning and social competence and social support, providing support for other researchers who have found similar relationships (e.g., Holt, 2014, Rhoades & Wood, 2014). There were also significant positive direct effects between family functioning and well-being and significant negative direct effects between family functioning and depression, anxiety, and stress; although these effects were considered minimal. Despite the limitations of these relationships, these findings support theories asserting the impact of family functioning on individuals' mental health (e.g., Olson, 2011, Thoits, 2011). Therefore, hypotheses one through three (i.e., that family functioning will predict higher social competence, higher levels of perceived support, and higher levels of well-being/lower levels of psychological symptoms) were accepted. Hypothesis four was also accepted, as social support directly positively predicted well-being and directly negatively predicted depression, anxiety, and stress. It should be noted that social support had both small and medium effects in predicting symptomatology and well-being, respectively, and that these were the largest effects observed in the SEM. These effects support the substantial body of literature finding that social support directly influences individuals' mental health (e.g., Hefner & Eisenberg, 2009; Thoits, 2011).

In addition to the lack of multivariate normality, several factors could have potentially contributed to the model's lack of fit. The first factor is that the a priori model

was incorrect, suggesting that the relationships among variables was not tenable. This assumption would suggest that although relationships have been found between family functioning and mental health (e.g., Brack et al., 2002; Hoffman & Weiss, 1987; Johnson, 1993), family functioning and social behavior (e.g., Robinson et al., 1995), and social support and mental health (e.g., Hefner & Eisenberg, 2009), these variables are not interrelated. Furthermore, this conclusion may indicate that although assumptions can be made about the relationships between the circumplex model of family functioning (Olson, 2011), social cognitive theory (Bandura, 1986), attachment theory (Bowlby, 1969), and theories of social support (Thoits, 2011), these theories are tenuously related, if at all. This consideration was likely also influenced by the fact that although relationships have been found among these variables in the literature, the a priori model was not based on strong, empirically supported theoretical model.

The second factor potentially contributing to the model's lack of fit could be that unique characteristics of the sample itself did not fit the model well. A larger and more diverse sample may have led to different results. However, the sample in this study was more diverse than most found in the current body of literature, which have typically utilized convenience samples of a small number of institutions (e.g., Ponappa et al., 2016; Reed et al., 2015; Rhoades & Wood, 2014). A third and final factor contributing to the results may have been the selection of measures or methodology. Measures were selected based on reports of high internal reliability and evidence of a stable factor structure. However, the FACES-IV displayed low internal reliability and a theoretical factor structure that did not fit the data well. Regarding methodology, SEM was selected based on its rigor and ability to make causal inferences. However, the researcher could have

utilized different measures of each construct or more exploratory methodologies. For example, Johnson (1993) utilized the Borromeo Family Index for Single Persons (Bardis, 1975) to measure family relationships and utilized simple correlations and multiple regression to analyze the predictive relationships between family functioning and mental health. Furthermore, the FACES-IV measures current family functioning, which may not have a significant influence on social competence, as social cognitive theory (Bandura, 1986) suggests that family functioning over the lifespan is the primary model of social behavior. It may be that current family functioning is not as relevant to students' mental health when they are physically separated from the family while attending college.

**Research Question #2: Does social competence mediate the relationship between family functioning and social support among college students?**

Social competence did mediate the relationship between family functioning and social support, although only slightly. It may be that current family functioning has less of an impact on social competence than interpersonal systems in students' college environment. Furthermore, social competence may not be a strong predictor of social support, weakening its power to mediate the proposed relationship. Despite a small effect, these findings led the researcher to accept hypothesis five (i.e., that the relationship between family functioning and perceived social support will be mediated by social competence), as the path indicated a significant indirect prediction of social support from family functioning as mediated by social competence.

**Research Question #3: Does social support mediate the relationship between family functioning and mental health among college students?**

Results from the path analysis indicated that social support mediated the relationship between family functioning and mental health. Specifically, social support had a small positive mediating effect on well-being and a small negative mediating effect on depression, anxiety, and stress. These findings support previous researchers that have found a relationship between family functioning and mental health (e.g., Hoffman & Weiss, 1987; Uruk et al., 2007) as well as a relationship between social support and mental health (e.g., Hefner & Eisenberg, 2009). Despite their mediating effects being small, the researcher chose to accept hypothesis six (i.e., That the relationship between family functioning and mental health will be mediated by perceived social support) on the basis that there was a significant mediating effect of social support on the ability of family functioning to predict well-being and mental health symptomatology.

**Research Question #4: Do participants' family functioning, social competence, social support, and mental health differ according to demographic and institutional characteristics?**

Results from comparisons of family functioning across ethnicity did not indicate significant differences. This finding may imply that although collectivism and family connectedness may be differentially emphasized across cultures, idiosyncrasies across individual family systems may override larger cultural norms within this sample. In terms of social competence, there were no differences between traditionally and nontraditionally aged students. This finding is interesting, as theoretically, nontraditionally aged students may have more time and life experiences to assist in building their social competence.

On the other hand, significant differences did exist in social competence across groups based on institution size. Students in the current study who were attending large institutions (i.e., greater than 10,000 students) reported higher social competence than students attending medium institutions (i.e., 3,000 to 9,000 students). It may be that students from larger institutions have to learn to be more socially competent as they navigate campuses with larger and more complex social systems. It may also be that students who are more socially competent seek out larger social systems. However, the effect of the difference was small, indicating that although these groups were different, this difference only accounted for a small proportion of the variance between the groups. Thus, differences should be interpreted with caution. Students from small institutions reported similar levels of social competence to students from large and medium institutions, indicating that students from small institutions may be engaging in their social environments similarly to students from other institutions despite differences in population size.

In terms of social support, females reported significantly higher social support than males. This finding confirms previous findings on the existence of gender differences in social support (Matud, Ibanez, Bethencourt, Marrero, & Carballeira, 2003) and may be reflective of greater interpersonal sensitivity among women (McClure, 2000). However, this difference indicated a less than small effect, which may indicate that although differences are statistically significant, they may not be practically significant. Conversely, there were no significant differences in social support between traditionally aged and non-traditionally aged students. As with social competence, although



nontraditionally aged students may have had more life experience, this does not necessarily influence their ability to successfully build social support.

Students reported differing levels of well-being and mental health symptomatology across age category and class rank. Traditionally aged college students reported higher levels of mental health symptomatology than their nontraditionally aged peers, although this difference evidenced a small effect. This finding suggests that nontraditionally aged students may feel better able to navigate the challenges of the college environment or that their age had led them to experience a decrease in risk factors for developing mental health symptoms. Lower levels of well-being and higher levels of symptomatology in the current study indicate that the Junior year is more difficult to navigate than other years. Furthermore, these differences indicated a medium effect size, which may lend support to the practical significance of Junior's mental health from other years. It seems that the Junior year may present unique challenges that are qualitatively different than other years, thus resulting in reduced well-being and increased symptomatology. Examples of such challenges could be more difficult, advanced courses, anticipation of the end of the college experience, pressure to consider future careers or education, and most students turning 21 years old, the age in which alcohol consumption is legal. The finding of higher levels of symptomatology among women also reflects global trends in mental health (World Health Organization, 2013), although this difference indicated a small effect. Women are at higher risk for developing common mental health disorders, such as depression, anxiety, and psychosomatic symptoms, which reflect risk factors such as gender-based stressors, negative life experiences, and roles.

## **Implications for Mental Health Practice**

The findings of this study yield several possible recommendations for practice in the mental health field. The primary recommendation is that mental health practitioners on college campuses should consider the impact that family functioning, social competence, and social support have on students' mental health. Many practitioners working in the college setting have likely heard about and addressed issues related to family functioning, social competence, and social support, as such issues have shown to be prevalent among student populations (Center for Collegiate Mental Health, 2018). Although the suggested model did not fit the data, each factor in the model was predictive of students' mental health.

Family functioning directly predicted social competence, social support, and mental health. Despite the small effect of family functioning on these variables, practitioners may benefit from working directly with students and their families to improve family functioning, as this may lead to improved social competence, increased social support, and decreased mental health symptomatology among students. Furthermore, students identify family problems as a primary presenting concern in college counseling centers (Center for Collegiate Mental Health, 2018), thus indicating family as a potential area for intervention regarding students seeking out mental health services on campus. Haber and Merck (2010) encouraged mental health practitioners on college campuses to utilize students' families as a resource in mental health treatment. Specifically, practitioners can work with students and their families to resolve family issues and to facilitate emotional support of the student from family members. Working with a student's family may thus serve to improve social competence, social support, and

mental health directly through family functioning and indirectly through increases in perceived social support.

Mental health practitioners working with college students may also want to utilize therapeutic techniques or treatments that assist students in building their social competence or utilizing social support, as these factors also indirectly (i.e., through the mediation of social competence) and directly influenced students' mental health. Examples of such interventions include: (a) role-playing with students during an individual session to work on interpersonal assertiveness and communication, (b) facilitating interpersonal process or support groups to encourage improvements in social competence and creation of new social supports among students, and (c) developing or utilizing programs that encourage peer social support networks regarding mental health issues (i.e., Byrom, 2018). Interventions facilitating social support from family, friends, and significant others should be a primary consideration, given that social support was the strongest predictor of well-being and mental health symptomatology.

Finally, practitioners should consider that differences in social competence, social support, well-being, and mental health symptomatology across different groups of students. Practitioners working with males should also consider interventions that assist in building social support, given that findings from this study and others (Matud et al., 2003) indicate that males report lower levels of social support than females. Finally, practitioners may benefit from being aware of factors that influence higher rates of mental health symptomatology among traditionally aged students, females, and students completing their Junior year. Practitioners should explore how these identities impact

individual students' mental health along with other factors related to treatment goals and outcomes.

### **Limitations**

One limitation of the current study was the lack of reliability and alternative factor structure of the FACES-IV. A second limitation is the generalizability of the sample. Although random sampling procedures were used to select institutions, a low response rate may have resulted in response bias, thus inviting the risk that students may not have been representative of their specific institution or the broader landscape of higher education. Furthermore, the generalizability of the sample may be confounded due to the limited number of institutions being sampled. The sample was a convenience sample in that only institutions that were willing to provide contact data about their students were included in the study.

A third limitation was the cross-sectional design, making causation difficult to imply. Problems inherent in SEM present a fourth limitation and include: (a) the omission of variables implicated in the processes or features of a model, (b) problematic lower-order components despite model fit, (c) problems with estimates and tests of parameters, (d) ignoring alternative models that fit data equally well or better, and (e) inaccurate rules of structural equation modeling concerning assessment of fit (Tomarken & Waller, 2005). Despite these limitations, SEM was chosen due to its strengths, primarily (a) the ability to specify latent variable models and provide separate estimates of relations among latent constructs, (b) availability of measure of global fit that can summarize complex models, and (c) the ability to evaluate alternative models using comparative fits (Tomarken & Waller, 2005).

## **Recommendations for Future Research**

Based on the limitations and findings of this study, several recommendations exist for future research. Although an acceptable model of the FACES-IV was indicated, low reliability in the enmeshment and rigidity subscales suggest that this measure may need further development to accurately measure family functioning among college students. Researchers may benefit from utilizing a more reliable and valid instrument measuring family functioning, such as the Systemic Clinical Outcome and Routine Evaluation (SCORE; Stratton, Bland, Janes, & Lask, 2010) which has demonstrated adequate to excellent reliability as well as a stable factor structure. As noted previously, the FACES was used in this study because it had demonstrated adequate reliability and strong factor structure in previous studies (Olson, 2011). Furthermore, researchers examining the relationship between family functioning and current social competence may benefit from utilizing measures that examine historical family functioning, as this seems to fall more in line with the tenets of social cognitive theory.

Future research examining the influence of family functioning, social support, and social competence on college students' mental health may also benefit from utilizing different samples, methodologies, or analyses. Although large and heterogeneous in terms of geographic location and institution, the sample in this study was relatively homogenous regarding gender and ethnicity. Purposive sampling of minority populations may provide a more representative sample and help researchers understand differences across the study variables regarding ethnicity. Through efforts to create a more diverse and representative sample, findings of future studies can be more generalizable to the larger population of college students.

Along with utilizing a more diverse sample, researchers might apply different research methodologies to further examine how family functioning, social support, and social competence function regarding students' mental health. Qualitative phenomenological or narrative research approaches might serve to increase our understanding of how students' experience family functioning, social competence, and social support while attending college. More exploratory quantitative analyses (e.g., correlation, multiple regression) may provide different insights into how family functioning, social competence, and social support are related to mental health without some of the assumptions required by SEM (e.g., a-prior hypothesis, multivariate normality). Researchers may also be able to support causal inferences by utilizing longitudinal studies which measure how students' family functioning influences social competence, social support, and mental health over time.

### **Conclusion**

The prevalence and severity of mental health problems have been increasing in recent years among college students in the United States (Xiao et al., 2017). Although institutions of higher education provide support to students experiencing mental health difficulties, students' family of origin are often not included in these efforts (Eichler & Schwartz, 2010). The family of origin often influences mental health directly through family functioning (e.g., Brack et al., 2002; Hoffman & Weiss, 1987; Johnson, 1993) and indirectly through students' social competence (e.g., Bandura, 1986; Brack et al., 2002) and subsequent ability to build and utilize social support (e.g., Hefner & Eisenberg, 2009). The findings of this study provide initial evidence that students' family functioning, social competence, and social support are variables related to their mental

health. Although the three variables did not fit the researcher's proposed a priori theoretical/empirical model, the findings of the current study suggest that researchers and practitioners should continue to consider the impact of students families' and social networks on their mental health while attending college.





Figure 2. FACES-IV Model 2

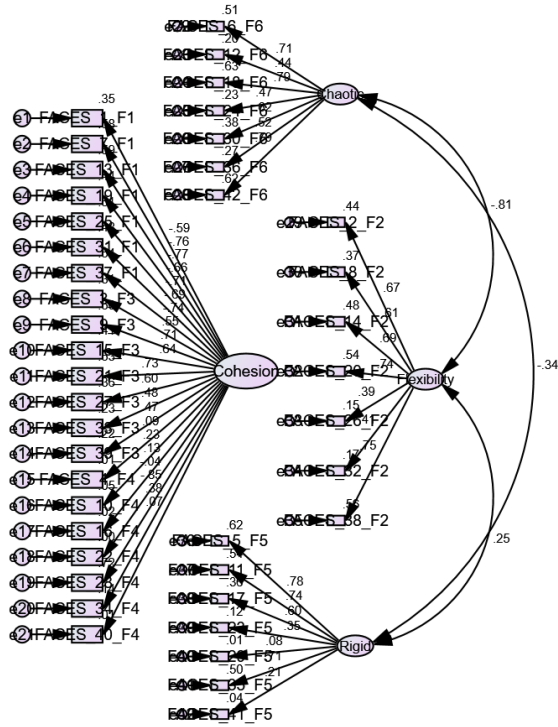

Figure 3. FACES-IV Model 3

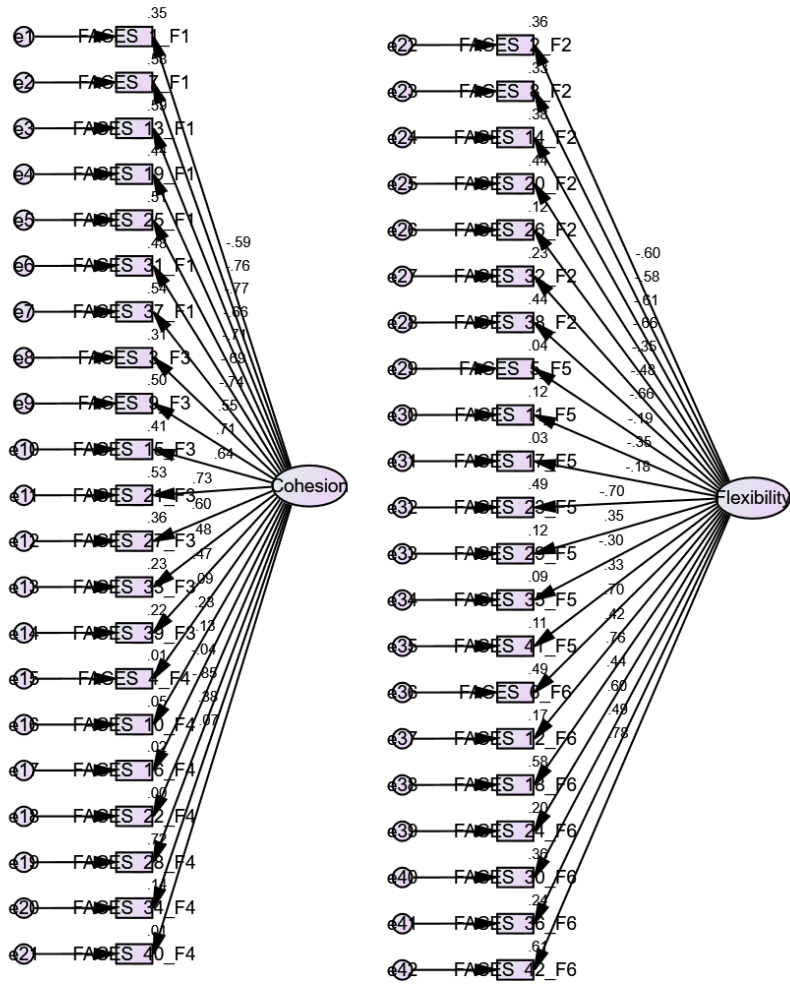

Figure 4. TSBI Model

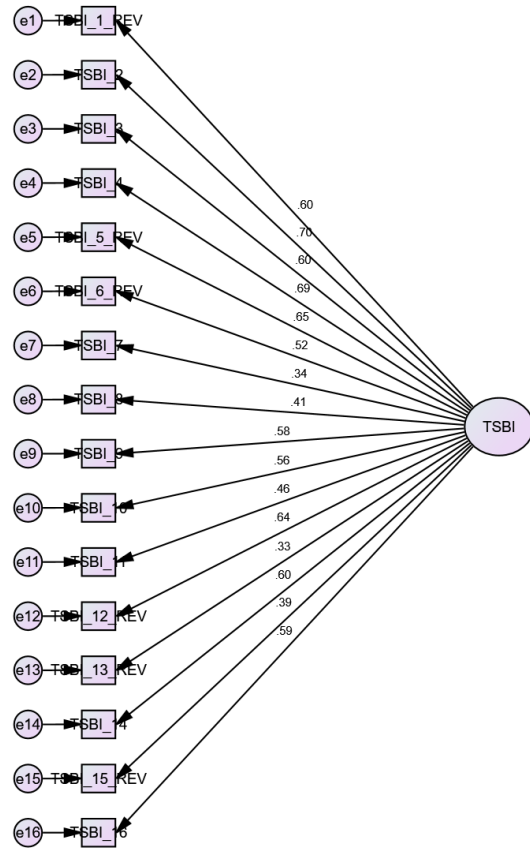

Figure 5. MSPSS Model

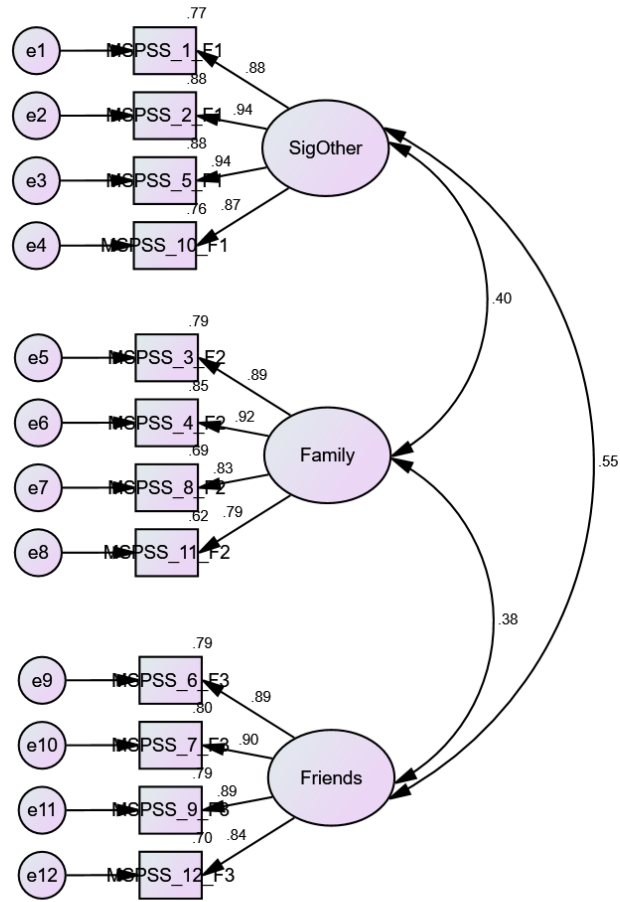

Figure 6. MHC-SF Model 1

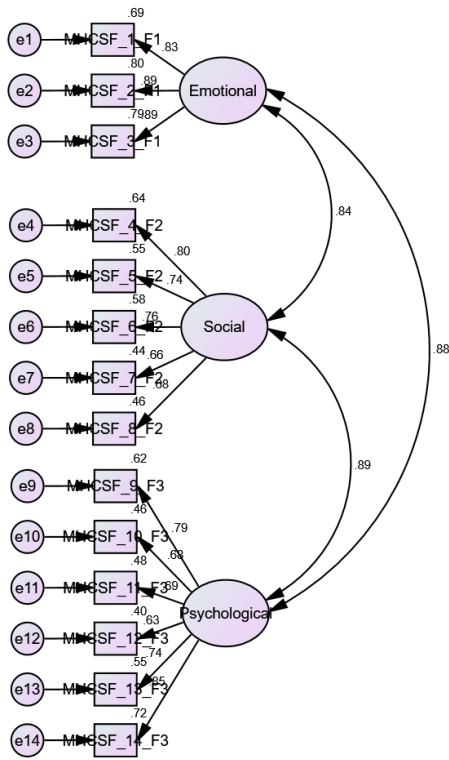

Figure 7. MHC-SF Model 2

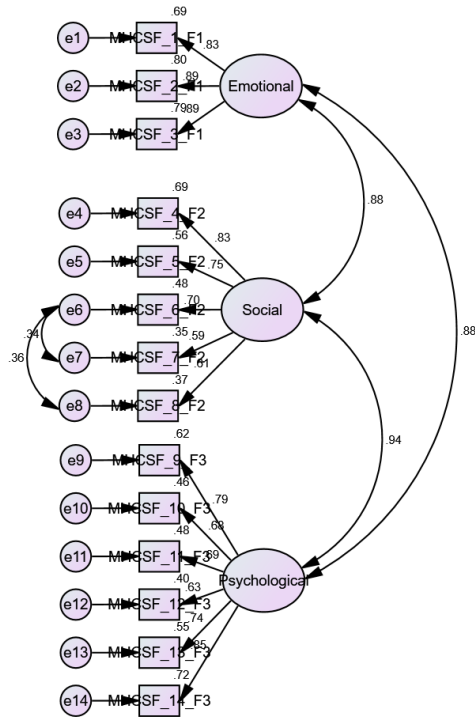

Figure 8. DASS-21 Model 1

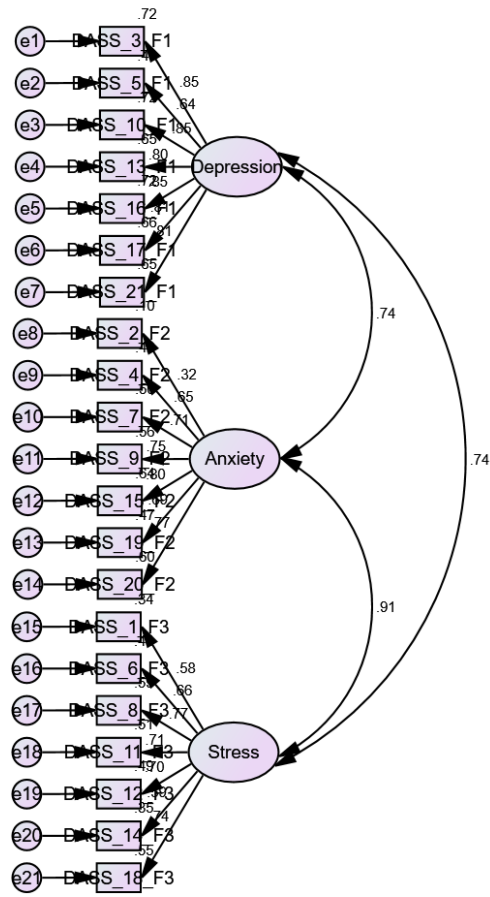
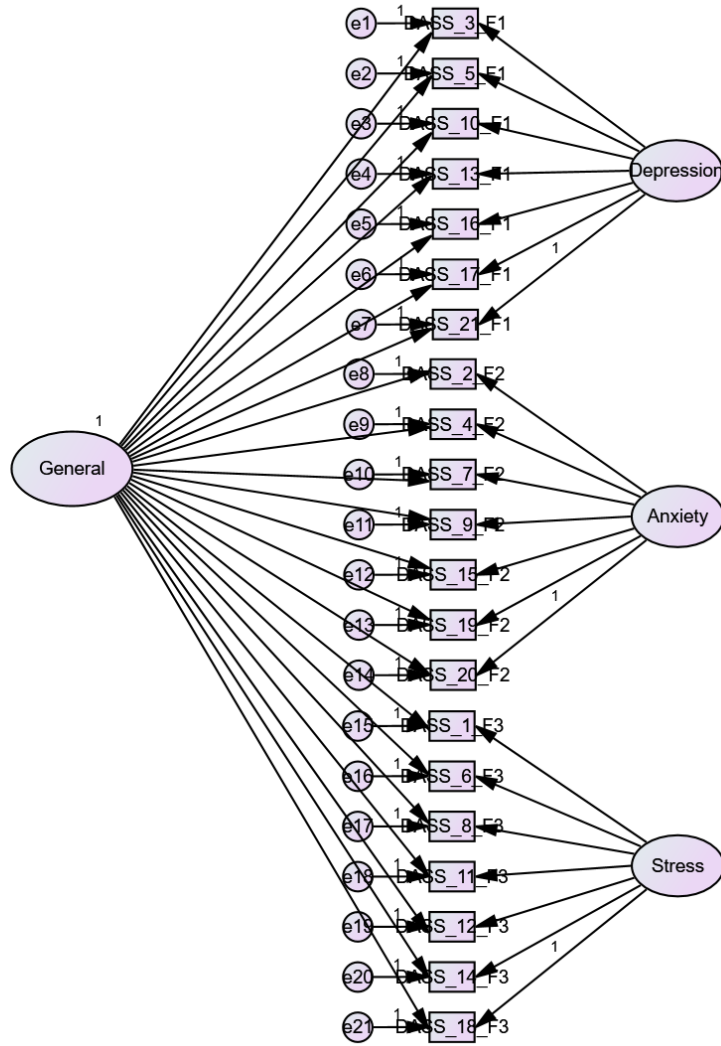

Figure 9. DASS-21 Model 2





Appendix B

Figure 1. SEM 1

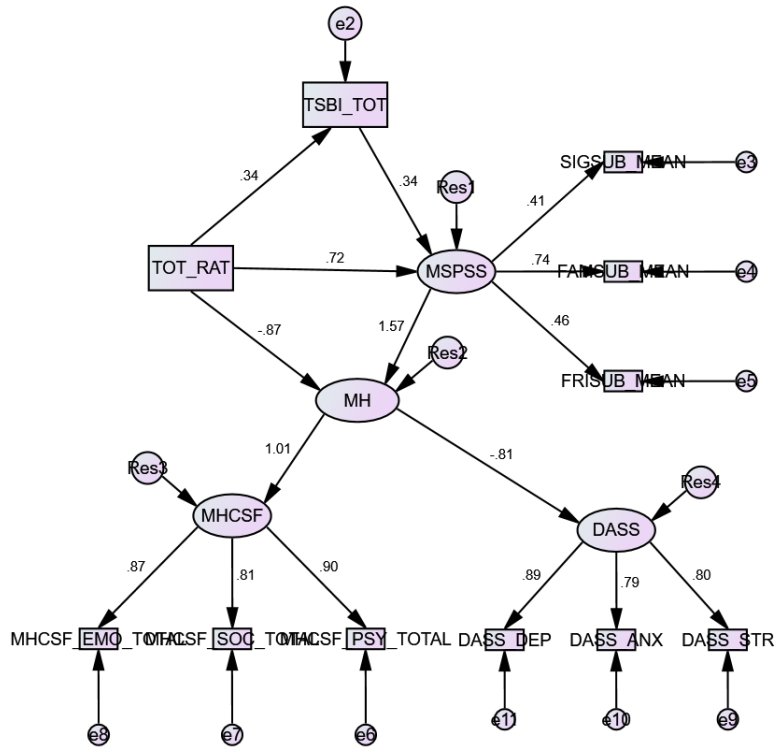

Figure 2. SEM 2

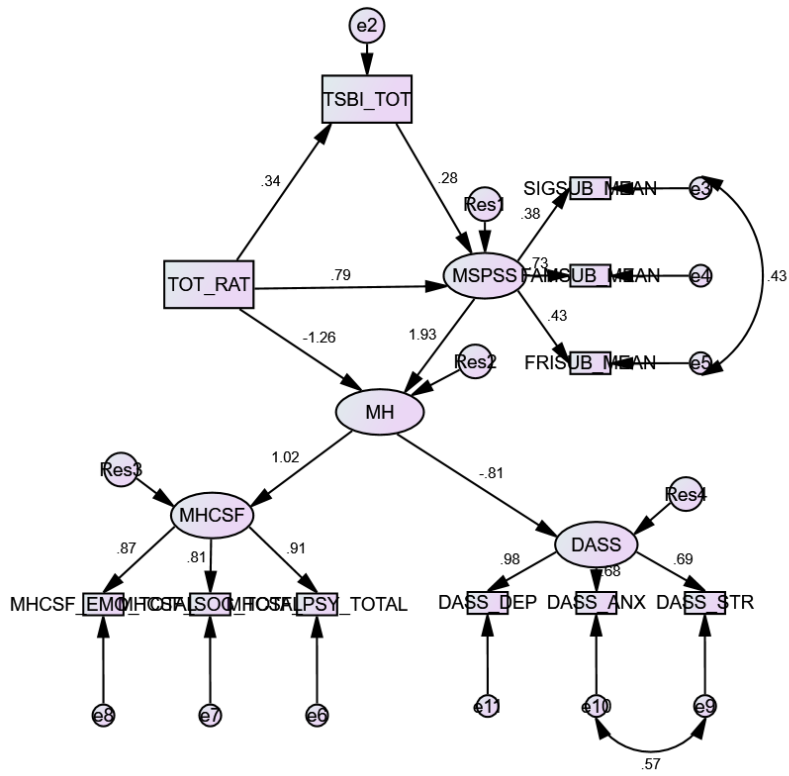

Figure 3. SEM 3

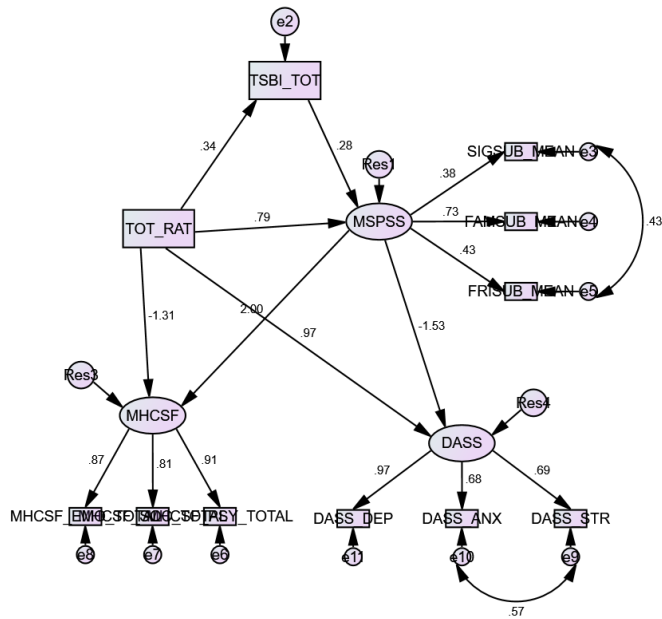

Figure 4. SEM 4

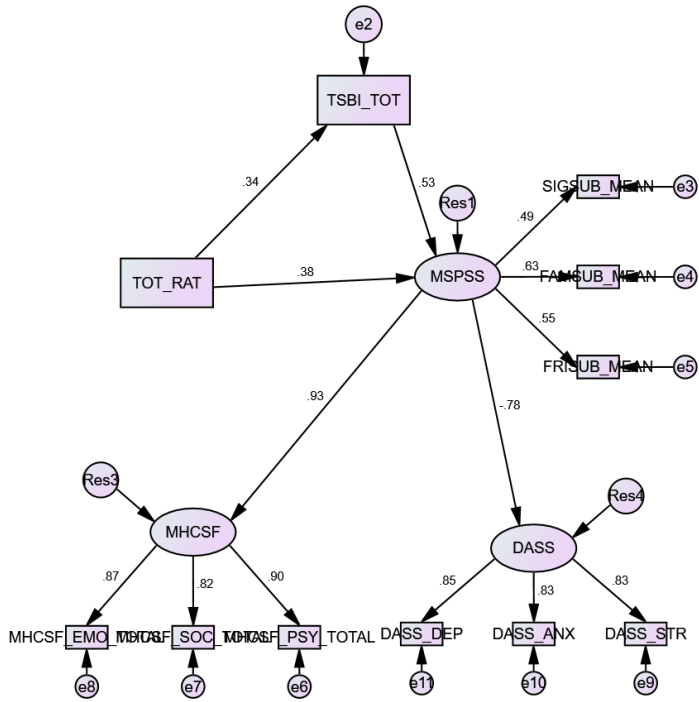

Figure 5. SEM 5

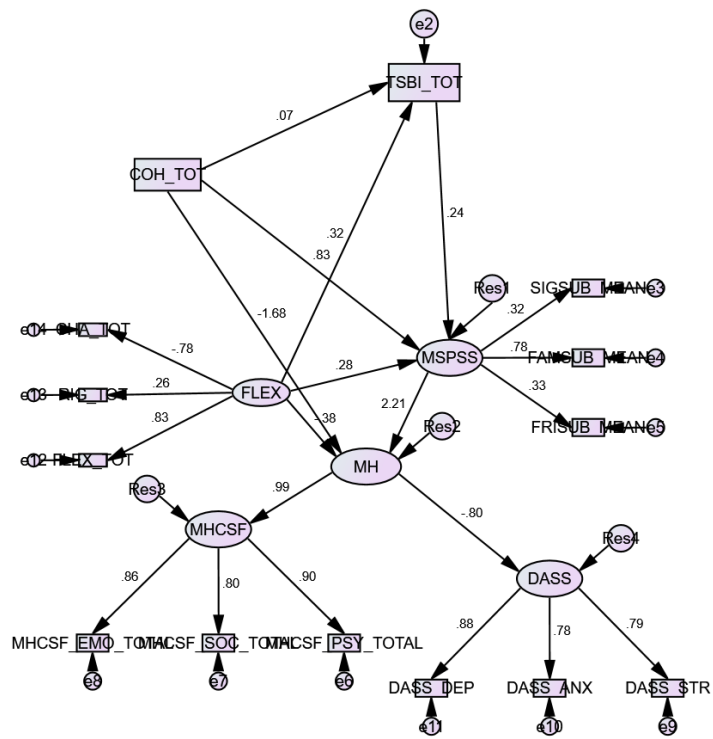

Figure 6. SEM 6

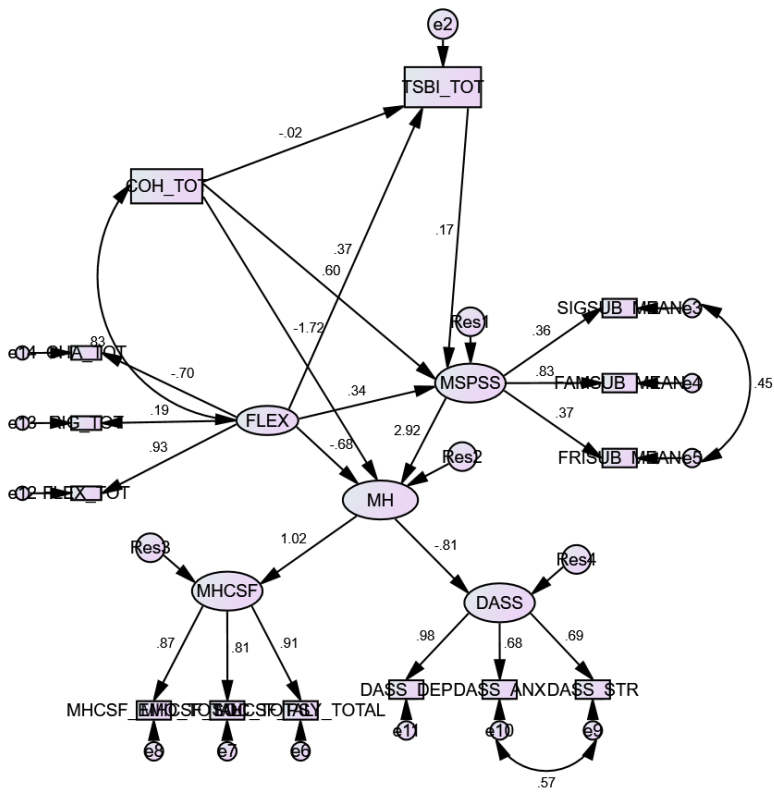

Figure 7. SEM 7

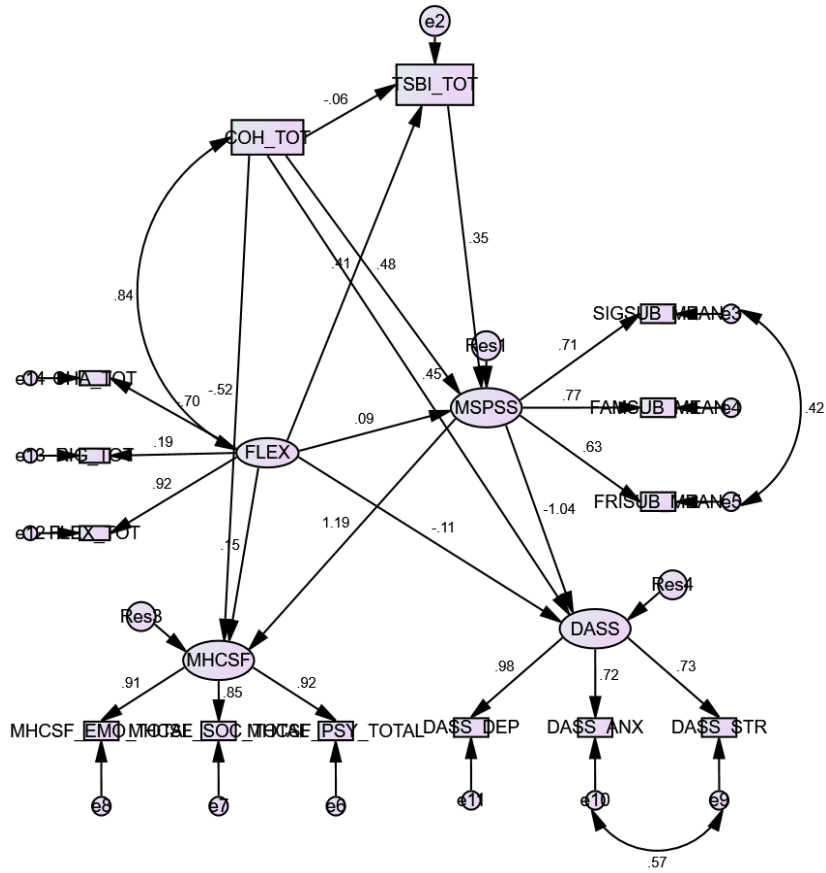

Figure 8. SEM 8

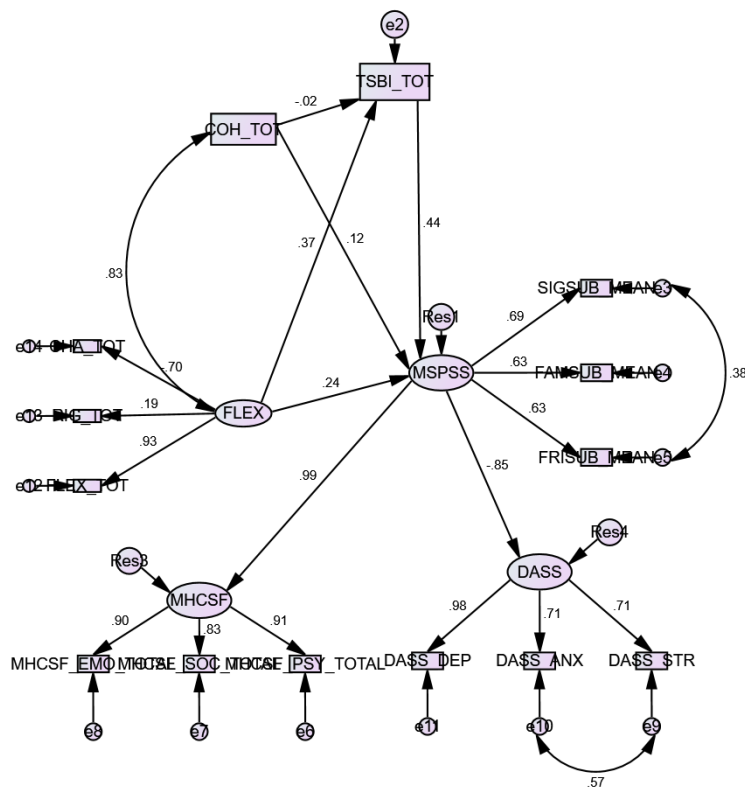
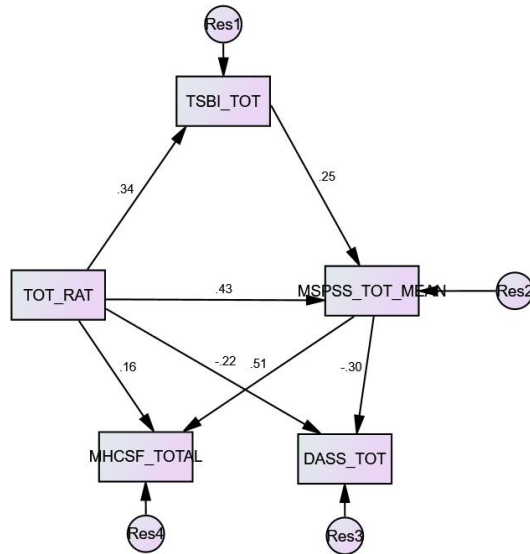



Figure 9. Observed Model



## References

- Ainsworth, M. D., Blehar, M. C., Waters, E., & Wall, S. (1978). *Patterns of attachment: A psychological study of the strange situation*. Oxford, England: Lawrence Erlbaum.
- Arbuckle, J. L. (2016). Amos (Version 24.0) [Computer Program]. Chicago: IBM SPSS.
- Baker, R. W., McNeil, O. V., & Siryk, B. (1985). Expectation and reality in freshman adjustment to college. *Journal of Counseling Psychology, 32*, 94-103.
- Bandura, A. (1986). *Social foundations of thought and action: A social cognitive theory*. Englewood Cliffs, NJ: Prentice Hall.
- Bardis, P. D. (1975). The Borromean family. *Social Science, 50*(3), 144-158.
- Beavers, R., & Hampson, B. (2000). The beavers systems model of family functioning. *Journal of Family Therapy, 22*, 128-143.
- Bell, N. J., Avery, A. W., Jenkins, D., Feld, J. & Schoenrock, C. J. (1985). Family relationships and social competence during late adolescence. *Journal of Youth and Adolescence, 14*(2), 109-119.
- Bell, L. G., Cornwell, C. S., & Bell, D. C. (1988). Peer relationships of adolescent daughters: A reflection of family relationship patterns. *Family Relations, 37*(2), 171-174.
- Bentler, P. M. (1990). Comparative fit indexes in structural models. *Psychological Bulletin, 107*, 238-246.
- Bentler, P. M. (2005). *EQS 6 Structural equations program manual*. Encino, CA: Multivariate Software Inc.

- Benton, S. A., Robertson, J. M., Tseng, W., Newton, F. B., & Benton, S. L. (2003). Changes in counseling center client problems across 13 years. *Professional Psychology: Research and Practice*, 34(1), 66–72. <https://doi.org/10.1037/0735-7028.34.1.66>
- Bowlby, J. (1969). *Attachment and loss: Vol. I. Attachment*. London: Hogarth.
- Brack, C. J., Brack, G., Charbonneau, M., & Hill, M. (2002). Family of origin characteristics and symptomatology in a counseling center population. *Journal of College Student Psychotherapy*, 17(2), 53-73.
- Byrne, B. M. (2016). *Structural equation modeling with amos: Basic concepts, applications, and programming* (3rd ed.). New York: Routledge.
- Cassidy, J., Jones, J. D., & Shaver, P. R. (2013). Contributions of attachment theory and research: A framework for future research, translation, and policy. *Development and Psychopathology*, 25, 1415-1434.
- Center for Collegiate Mental Health. (2018). *2017 Annual Report* (Publication No. STA 18-166).
- Cohen, J. (1988). *Statistical power analysis for the behavioral sciences* (2nd ed.). Hillsdale, NJ: Lawrence Erlbaum.
- Cohen, S. (2004). Social relationships and health. *American Psychologist*, 59, 676–684. <http://dx.doi.org/10.1037/0003-066X.59.8.676>
- Cohen S, Gottlieb B, & Underwood L. (2000). *Social relationships and health: Challenges for measurement and intervention*. New York: Oxford University Press.

- Cohen, S., & Wills, T. A. (1985). Stress, social support, and the buffering hypothesis. *Psychological Bulletin*, 98(2), 310-357.
- Collins, M. E., & Mowbray, C. T. (2005). Higher education and psychiatric disabilities: National survey of campus disability services. *American Journal of Orthopsychiatry*, 75, 304–315.
- DeDonno, M. A., & Fagan, J. F. (2013). The influence of family attributes on college students' academic self-concept. *North American Journal of Psychology*, 15(1), 49-62.
- Dekovic, M., & Meeus, W. (1997). Peer relations in adolescence: Effects of parenting and adolescents' self-concept. *Journal of Adolescence*, 20, 163-176.
- Dillman, D. A., Smyth, J. D., & Chrisitina, L. M. (2014). *Internet, phone, mail, and mixed-mode survey: The tailored design method* (4th ed.). Hoboken, NJ: John Wiley.
- Eichler, R. J., & Schwartz, V. (2010). Essential services in college counseling. In J. Kay & V. Schwartz (Eds.), *Mental Health Care in the College Community* (pp. 57-94). West Sussex: Wiley.
- Engel, G. L. (1977). The need for a new medical model: A challenge for biomedicine. *Science*, 196(4286), 129-136.
- Erdur-Baker, O., Aberson, C. L., Barrow, J. C., & Draper, M. R. (2006). Nature and severity of college students' psychological concerns: A comparison of clinical and nonclinical national samples. *Professional Psychology: Research and Practice*, 37(3), 317–323. <https://doi.org/10.1037/0735-7028.37.3.317>

- Farrell, M., & Langreher, K. J. (2017). Stress, social support, and psychosocial functioning of ethnically diverse students. *Journal of College Counseling, 20*, 208-223.
- Fowler, F. J. (2013). *Survey research methods* (5th ed.). Thousand Oaks, CA: Sage.
- Gans, S. E., & Johnson, V. K. (2016). Cortisol response to family interaction as a predictor for adjustment. *Journal of Family Psychology, 30*(7), 812-821.
- Green, J. M., & King, A. R. (2009). Domestic violence and parental divorce as predictors of best friendship qualities among college students. *Journal of Divorce & Remarriage, 50*, 100-118.
- Haber, R., & Merck, R. A. (2010). Intruder or resource? The family's influence in college counseling centers. *Journal of College Student Psychotherapy, 24*, 162-180.
- Hays, R. B., & Oxley, D. (1986). Social network development and functioning during a life transition. *Journal of Personality and Social Psychology, 50*(2), 305-313.
- Hefner, J., & Eisenberg, D. (2009). Social support and mental health among college students. *American Journal of Orthopsychiatry, 79*(4), 491-499.
- Helmreich, R., & Stapp, J. (1974). Short forms of the Texas social behavior inventory (TSBI), an objective measure of self-esteem. *Bulletin of the Psychonomic Society, 4*(5A), 473-475.
- Hoffman, J. A., & Weiss, B. (1987). Family dynamics and presenting problems in college students. *Journal of Counseling Psychology, 34*(2), 157-163.
- Holmbeck, G. N., & Wandrei, M. L. (1993). Individual and relational predictors of adjustment in first-year college students. *Journal of Counseling Psychology, 40*(1), 73-78.

- Holt, L. J. (2014). Help seeking and social competence mediate the parental attachment-college student adjustment relation. *Personal Relationships, 21*, 640-654.
- IBM SPSS Statistics for Windows (Version 25) [Computer software]. Armonk, NY: IBM Corp.
- Indiana University Center for Postsecondary Research. (2015). The Carnegie classification of institutions of higher education. Bloomington, IN: Author.
- Johnson, J. G. (1993). Associations between family relationships and psychiatric symptomatology in undergraduate students: An investigation of gender differences. *Journal of College Student Psychotherapy, 7*(3), 79-95.
- Joshanloo, M., Wissing, M. P., Khumalo, I. P., & Lamers, S. M. A. (2013). Measurement invariance of the mental health continuum-short form (MHC-SF) across three cultural groups. *Personality and Individual Differences, 55*(7), 755-759.
- Kay, J. (2010). The rising prominence of college and university mental health issues. In J. Kay & V. Schwartz (Eds.), *Mental Health Care in the College Community* (pp. 1-20). West Sussex: Wiley.
- Kazarian, S. S., & McCabe, S. B. (1991). Dimensions of social support in the MSPSS: Factorial structure, reliability, and theoretical implications. *Journal of Community Psychology, 19*, 150-160.
- Kenny, M. E., & Donaldson, G. A. (1991). Contributions of parental attachment and family structure to the social and psychological functioning of first-year college students. *Journal of Counseling Psychology, 38*(4), 479-486.

- Keyes, C. L. M. (2005). Mental illness and/or mental health? Investigating axioms of the complete state model of health. *Journal of Counseling and Clinical Psychology, 73*, 539-548.
- Keyes, C. L. M., Eisenberg, D., Perry, G. S., Dube, S. R., Kroenke, K., & Dhingra, S. S. (2012). The relationship of level of positive mental health with current mental disorders in predicting suicidal behavior and academic impairment in college students. *Journal of American College Health, 60*(2), 126-133.
- Kia-Keating, M., No, U., Moore, S., Furlong, M. J., Liu, S., & You, S. (2017). Structural validity of the depression, anxiety, and stress scales-21 adapted for U.S. undergraduates. *Emerging Adulthood, 1-7*.
- Kimble, C., & Helmreich, R. (1972). Self-esteem and the need for social approval. *Psychonomic Science, 26*, 339-342.
- Kirk, R. E. (1996). Practical significance: A concept whose time has come. *Educational and Psychological Measurement, 56*, 746-759.
- Kumar, S. A., & Mattanah, J. F. (2018). Interparental conflict, parental intrusiveness, and interpersonal functioning in emerging adulthood. *Personal Relationships*.
- Lauer, R. H., & Lauer, J. C. (1991). The long-term relational consequences of problematic family backgrounds. *Family Relations, 40*(3), 286-290.
- Li, S. T., Albert, A. B., & Dwelle, D. G. (2014). Parental and peer support as predictors of depression and self-esteem among college students. *Journal of College Student Development, 55*(2), 120-138.
- Lopez, F. G. (1991). Patterns of family conflict and their relation to college student adjustment. *Journal of Counseling & Development, 69*, 257-260.

- Lopez, F. G., Campbell, V. L., & Watkins, C. E. (1989). Constructions of current family functioning among depressed and nondepressed college students. *Journal of College Student Development, 30*, 221-228.
- Lovibond, S. H., & Lovibond, P. F. (1995). *Manual for the Depression Anxiety Stress Scales. Psychological foundation of Australia* (Vol. 56).
- Lustig, D. C., Xu, Y. J., & Strauser, D. R. (2017). The influence of family of origin relationships on career thoughts. *Journal of Career Development, 44*(1), 49-61.
- MacCallum, R. C., & Austin, T. J. (2000). Applications of structural equation modeling in psychological research. *Annual Review of Psychology, 51*, 201-226.
- MacCallum, R. C., Browne, M. W., & Sugawara, H. M. (1996). Power analysis and determination of sample size for covariance structure models. *Multivariate Behavioral Research, 29*, 130-149.
- Marsac, M., & Alderfer, M. (2011). Psychometric properties of the FACES-IV in a pediatric oncology population. *Journal of Pediatric Psychology, 36*(5), 528-538.
- Mattanah, J. F., Lopez, F. G., & Govern, J. M. (2011). The contributions of parental attachment bonds to college student development and adjustment: A meta-analytic review. *Journal of Counseling Psychology, 58*(4), 565-596.
- Matud, M. P., Ibanez, I., Bethencourt, J. M., Marrero, R., & Carballeira, M. (2003). Structural gender differences in perceived social support. *Personality and Individual Differences, 35*, 1919-1929.
- McClure, E. B. (2000). A meta-analytic review of sex differences in facial expression processing and their development in infants, children, and adolescents. *Psychological Bulletin, 126*, 424-453.



- Merianos, A. L., Nabors, L. A., Vidourek, R. A., & King, K. A. (2013). The impact of self-esteem and social support on college students' mental health. *American Journal of Health Studies, 28*(1), 27-34.
- Mikulincer, M., & Shaver, P. R. (2007). *Attachment in adulthood: Structure, dynamics, and change*. New York: Guilford Press.
- Miller, I., Ryan, C., Keitner, G., Bishop, D., & Epstein, N. (2000). The McMaster approach to families: Theory, assessment, treatment and research. *Journal of Family Therapy, 22*, 168-186.
- Mounts, N. S., Valentiner, D. P., Anderson, K. L., & Boswell, M. K. (2006). Shyness, sociability, and parental support for the college transition: Relation to adolescents' adjustment. *Journal of Youth and Adolescence, 35*(1), 71-80.
- MPLUS (Version 8.2). [Computer Software]. Los Angeles, CA: Muthén & Muthén.
- National Center for Education Statistics. (2017). *Integrated Postsecondary Education Data System*. Retrieved from <https://nces.ed.gov/ipeds/use-the-data>
- Needham, B. L. (2008). Reciprocal relationships between symptoms of depression and parental support during the transition from adolescence to young adulthood. *Journal of Youth & Adolescence, 37*, 893-905.
- Olson, D. H. (1996). Clinical assessment and treatment interventions using the Circumplex Model. In F. W. Kaslow (Ed.), *Handbook of relational diagnosis and dysfunctional family patterns*. New York: John Wiley and Sons.
- Olson, D. H. (2000). Circumplex model of marital and family systems. *Journal of Family Therapy, 22*, 144-167.

- Olson, D. H. (2011). FACES IV and the circumplex model: Validation study. *Journal of Marital and Family Therapy*, 37(1), 64-80.
- Olson, D., Bell, R., & Portner, J. (1992). *FACES-II manual*. St. Paul, MN: University of Minnesota.
- Olson, D. H., Russell, C. S., & Sprenkle, D. H. (1989). *Circumplex model: Systemic assessment and treatment of families*. New York: Haworth Press.
- Olson, D.H., Portner, J., & Lavee, Y. (1985). *FACES III*. St Paul, MN: University of Minnesota.
- Parker, S., & Parker, H. (1991). Female victims of child sexual abuse: Adult adjustment. *Journal of Family Violence*, 6, 183-197.
- Ponappa, S., Bartle-Haring, S., Holowacz, E., & Ferriby, M. (2016). The family system and depressive symptoms during the college years: Triangulation, parental differential treatment, and sibling warmth as predictors. *Journal of Marital and Family Therapy*, 43(1), 145-158.
- Qualtrics. [Computer software]. Provo, UT: Qualtrics.
- Reed, K., Ferraro, A. J., Lucier-Greer, M., & Barber, C. (2015). Adverse family influences on emerging adult depressive symptoms: A stress process approach to identifying intervention points. *Journal of Child & Family Studies*, 24, 2710-2720.
- Reetz, D. R., Bershad, C., LeViness, P., & Whitlock, M. (2016). *The Association for University and College Counseling Center Directors Annual Survey, 2016*. Retrieved from Association for University and College Counseling Center Director's website:

<https://www.aucccd.org/assets/documents/aucccd%202016%20monograph%20-%20public.pdf>

- Reiss, D. (1981). *The family's construction of reality*. Cambridge, MA: Harvard University Press.
- Reuger, S. Y., Malecki, C. K., Pyun, Y., Aycock, C., & Coyle, S. (2016). Meta-analytic review of the association between perceived social support and depression in childhood and adolescence. *Psychological Bulletin*, *142*(10), 1017-1067.
- Rhoades, G. K., & Wood, L. F. (2014). Family conflict and college-student social adjustment: The mediating role of emotional distress about the family. *Couple and Family Psychology: Research and Practice*, *3*(3), 156-164.
- Rice, K. G., & Mulkeen, P. (1995). Relationships with parents and peers: A longitudinal study of adolescent intimacy. *Journal of Adolescent Research*, *10*(3), 338-357.
- Robinson, L. C., Garthoeffner, J. L. & Henry, C. S. (1995). Family structure and interpersonal relationship quality in young adults. *Journal of Divorce & Remarriage*, *23*(3/4), 23-43.
- Robitschek, C., & Keyes, C. L. M. (2009). The structure of Keyes' model of mental health and the role of personal growth initiative as a parsimonious predictor. *Journal of Counseling Psychology*, *56*, 321-329.
- Rodick, J. D., Henggler, S. W., & Hanson, C. L. (1986). An evaluation of family adaptability, cohesion evaluation scales (FACES) and the circumplex model. *Journal of Abnormal Child Psychology*, *14*, 77-87.

- Santini, Z. I., Koyanagi, A., Tyrovolas, S., Mason, C., & Haro, J. M. (2015). The association between social relationships and depression: A systematic review. *Journal of Affective Disorders, 175*, 53-65.
- Satorra, A., & Bentler, P. M. (1994). Corrections to test statistics and standard errors in covariance structure analysis. In A. von Eye & C. C. Clogg (Eds.), *Latent variables analysis: Applications for developmental research* (pp. 399-419). Thousand Oaks, CA: Sage.
- Schunk, D. H. (2012). Social cognitive theory. In K. R. Harris, S. Graham, T. Urdan, C. B. McCormick, G. M. Sinatra, & J. Sweller (Eds.), *APA educational psychology handbook, Vol. 1. Theories, constructs, and critical issues* (pp. 101-123). Washington, D. C.: American Psychological Association.
- Shelton, A. J., Wang, C., & Zhu, W. (2017). Perceived social supports and mental health: Cultural orientations as moderators. *Journal of College Counseling, 20*, 194-207.
- Soper, D. S. (2018). A-priori sample size calculator for structural equation models [Software]. Available from <http://www.danielsoper.com/statcalc>
- Spear, L.P. (2002) The adolescent brain and the college drinker: Biological basis of propensity to misuse alcohol. *Journal of Studies on Alcohol, 63*(2), 571–582.
- Stratton, P., Bland, J., Janes, E., & Lask, J. (2010). Developing an indicator of family function and a practicable outcome measure for systemic family and couple therapy: The SCORE. *Journal of Family Therapy, 32*, 232-258.
- Sun, S. W., Bell, N. J., Feng, D., & Avery, A. W. (2000). A longitudinal analysis of parental bonds and relational competencies during the college years. *International Journal of Adolescence and Youth, 8*, 149-181.

- Thoits, P. A. (2011). Mechanisms linking social ties and support to physical and mental health. *Journal of Health and Social Behavior*, 52, 145-161.
- Uruk, A. C., Sayger, T. V., & Cogdal, P. A. (2007). Examining the influence of family cohesion and adaptability on trauma symptoms and psychological well-being. *Journal of College Student Psychotherapy*, 22(2), 51-63.
- U. S. Department of Education, Institute of Education Sciences, National Center for Education Statistics. (2018). *Total fall enrollment in degree-granting postsecondary institutions, by level and control of institution, attendance status, and sex of student: Selected years, 1970 through 2027*. Retrieved from [https://nces.ed.gov/programs/digest/d17/tables/dt17\\_303.30.asp](https://nces.ed.gov/programs/digest/d17/tables/dt17_303.30.asp)
- Waters, E., Hamilton, C. E., & Weinfield, N. S. (2000). The stability of attachment security from infancy to adolescence and early adulthood: General introduction. *Child Development*, 71, 678-683.
- West, S. G., Finch, J. F., & Curran, P. J. (1995). Structural equation models with non-normal variables: Problems and remedies. In R. H. Hoyle (Ed.), *Structural equation modeling: Concepts, issues, and applications* (pp. 56-75). Thousand Oaks, CA: Sage.
- Whitbeck, L., Hoyt, D., & Huck, S. (1994). Early family relationships, intergenerational solidarity, and support provided to parents by adult children. *Journals of Gerontology: Social Sciences*, 49, 585-594.
- Wickrama, K. A. S., Conger, R. D., Lopez, F. O., & Jung, T. (2008). Family antecedents and consequences of trajectories of depressive symptoms from adolescence to

young adulthood: A life course investigation. *Journal of Health and Social Behavior*, 49, 468-483.

World Health Organization. (2013). *Gender Disparities in Mental Health*. Geneva: Author.

Xiao, H., Carney, D. M., Youn, S. J., Janis, R. A., Castonguay, L. G., Hayes, J. A., & Locke, B. D. (2017). Are we in crisis? National mental health treatment trends in college counseling center. *Psychological Services*, 14(4), 407-415.

Zimet, G. D., Powell, S. S., Farley, G. K., Werkman, S., & Berkoff, K. A. (1990). Psychometric characteristics of the multidimensional scale of perceived social support. *Journal of Personality Assessment*, 55(3&4), 610-617.

Zimet, G. D., Dahlem, N. W., Zimet, S. G., & Farley, G. K. (1988). The multidimensional scale of perceived social support. *Journal of Personality Assessment*, 52, 30-41.

## Vita

Sean Michael Newhart was born on September 6, 1992 in Richmond, Virginia. Sean completed his B.S. in Psychology from James Madison University from 2010 to 2014. Sean then attended Clemson University to complete a M.Ed. and Ed.S. in Counselor Education, specifically, clinical mental health counseling, from 2014 to 2016. He will graduate with a Ph.D. in Counselor Education from William & Mary in May of 2019. Sean's clinical interests include family therapy, college counseling, and hospitalization programs. His research interests include counselor development, college students' mental health, and interventions for preventing or treating suicidality. Sean hopes to continue his counseling work after graduation as well as pursuing a career as a counselor educator.