

2005

An exploration of the relationship between the perception of the mother-daughter relationship, feminist consciousness and self-esteem in the adolescent/young adult daughter

Marcy J. Douglass
William & Mary - School of Education

Follow this and additional works at: <https://scholarworks.wm.edu/etd>



Part of the [Student Counseling and Personnel Services Commons](#), and the [Women's Studies Commons](#)

Recommended Citation

Douglass, Marcy J., "An exploration of the relationship between the perception of the mother-daughter relationship, feminist consciousness and self-esteem in the adolescent/young adult daughter" (2005). *Dissertations, Theses, and Masters Projects*. Paper 1550154053.
<https://dx.doi.org/doi:10.25774/w4-cs7j-pf69>

This Dissertation is brought to you for free and open access by the Theses, Dissertations, & Master Projects at W&M ScholarWorks. It has been accepted for inclusion in Dissertations, Theses, and Masters Projects by an authorized administrator of W&M ScholarWorks. For more information, please contact scholarworks@wm.edu.

AN EXPLORATION OF THE RELATIONSHIP BETWEEN
THE PERCEPTION OF THE MOTHER-DAUGHTER RELATIONSHIP,
FEMINIST CONSCIOUSNESS AND SELF-ESTEEM
IN THE ADOLESCENT/YOUNG ADULT DAUGHTER

A Dissertation

Presented to

The Faculty of the School of Education

The College of William and Mary in Virginia

In Partial Fulfillment

of the Requirements for the Degree

Doctor of Philosophy

by

Marcy J. Douglass

December, 2005

UMI Number: 3195890

Copyright 2006 by
Douglass, Marcy J.

All rights reserved.

INFORMATION TO USERS

The quality of this reproduction is dependent upon the quality of the copy submitted. Broken or indistinct print, colored or poor quality illustrations and photographs, print bleed-through, substandard margins, and improper alignment can adversely affect reproduction.

In the unlikely event that the author did not send a complete manuscript and there are missing pages, these will be noted. Also, if unauthorized copyright material had to be removed, a note will indicate the deletion.

UMI[®]

UMI Microform 3195890

Copyright 2006 by ProQuest Information and Learning Company.

All rights reserved. This microform edition is protected against unauthorized copying under Title 17, United States Code.

ProQuest Information and Learning Company
300 North Zeeb Road
P.O. Box 1346
Ann Arbor, MI 48106-1346

AN EXPLORATION OF THE RELATIONSHIP BETWEEN
THE PERCEPTION OF THE MOTHER-DAUGHTER RELATIONSHIP,
FEMINIST CONSCIOUSNESS AND SELF-ESTEEM
IN THE ADOLESCENT/YOUNG ADULT DAUGHTER

Marcy J. Douglass

Approved December 2005 by:

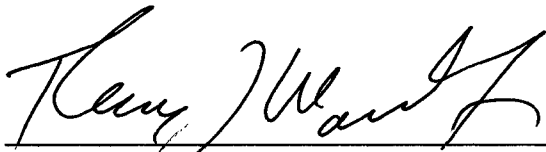

Thomas J. Ward, Jr. PhD
Co-Chair of Doctoral Committee



Victoria A. Foster, Ed.D.
Co-Chair of Doctoral Committee

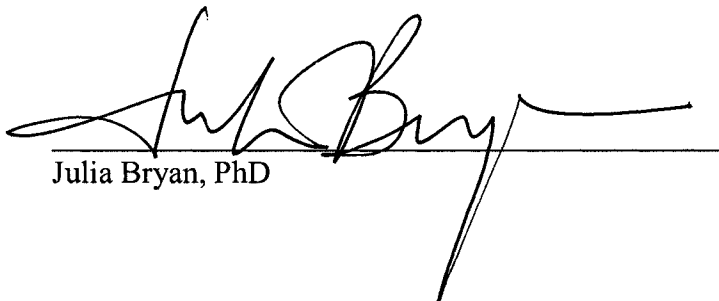

Julia Bryan, PhD

To My Family of Women

Florence - Grandmother

Jacquelyn - Mother

Ariel - Daughter

ACKNOWLEDGEMENTS

I am thrilled to be writing these acknowledgements as it means I am nearing the end of my time as a graduate student and moving toward another stage of my life. First and foremost I want to thank my wonderful husband Philip McCarthy, for your love, admiration, patience and sense of humor during this time. Your encouragement and faith kept me uplifted and forward thinking. To my daughter, Ariel Douglass-Devine, it has been my joy to be your mother, to share and learn with you. You are my inspiration and I thank you for your enthusiasm, support, confidence and for giving me pep. Your help with my data crash was incredible and the happy dance will live on!!! To my parents Jacquelyn and Henry Douglass, I am honored to be your daughter and I thank you for your unconditional love and support and for giving me roots and wings and the freedom to become my own person. A special thanks to my mother, Jacquie who always believed in me and my thinking, I appreciate your steadfast support and for taking the risks necessary to continue a legacy of strong women. To my brothers, John and Kirk Douglass, thank you for teaching me perseverance, it was truly helpful in this process. To my grandmother, Florence Fetterhoff for being an amazing role model for all women, your work ethic, honesty and unwavering love and encouragement.

It is with deep appreciation and heartfelt thanks that I recognize the following people whose support, guidance, patience and expertise have sustained me through the completion of my doctoral program and dissertation. I thank Dr. Victoria Foster for taking me on and her belief in my ability to succeed, enthusiasm for my subject matter, and her encouragement to stay the course. I thank Dr. Thomas J. Ward for his infinite patience and ability to help me understand sophisticated statistical analysis all the while keeping his sense of humor and to Dr. Julia Bryan, her steadfast presence and joyful heart were contagious and allowed me to press on in my writing endeavors. Also, Dr. Bruce Bracken, Dr. Judy Harris, Dr. Norma Day-Vines and Dr. Rick Gressard, your generosity of time and spirit are greatly appreciated. To Dr. Charles McAdams, your fine teaching was an inspiration to me to continue the program and bring to life my dream of becoming a counselor educator.

To my cohort Tom, Juliana, Angela, and Ed, I am thankful that you provided just the right balance of support and challenge. A special thanks to Tom Miller for his loyalty, thoughtfulness and ever present friendship, always remember blood, sweat and tears. To my school counseling

cohort: Tammi Milliken, Tim Grothaus and Susannah Wood, much appreciation for the camaraderie and your commitment to our field. Tammi, your friendship and guidance were invaluable, Tim, as a novice in the program you were my beacon in the dark; no question was too trivial, no concern too trite. You continue to shine your light on my life and for that I am sincerely grateful. To Susannah immense thanks for being a great friend, roommate, travel partner and sounding board. To Patti Burseson, Wendy Pearson, Deborah Walker and Carol Smart, for their friendship, attention and ears when I was desperately in need.

Many people have worked hard to support me in this endeavor. For their technical expertise I thank, Michele Moffit, Sean Pada and Mark Eaton, when the scanner was not reliable, they were. For your editing expertise I thank Susan McGowan and Susannah Wood. My mentors included Patricia Rea, Denyse Doerries and Susan Lamprecht, thank you for calming my anxieties and enhancing my confidence. A special thank you to Trish for steering me straight and keeping me on the right track, my appreciation is immeasurable. Also, immense gratitude to Sharon Flynn and Deborah Mazanek for assisting me in restoring my health without which this dissertation could never have been fully realized.

Also, I want to thank the liaisons, administrators and young women who made it possible to accomplish the task of collecting the research data for this dissertation. Elaine Rissinger, Suzanna Whitehead, Jacquelyn Douglass, Jeff Hughes, Barbara Kuhlen, Michelle McGinnis, Stephanie Hautz, Anna Graham, and Neil Stamm. Without your willingness, flexibility and belief in research, collecting data would have been much more cumbersome and time consuming. To the young women who shared a piece of themselves with me, this research could not have been realized without your willingness to participate. I thank you for your time and energy.

Finally, I must recognize my faithful dog, Roxette. For the past three and one-half years, as I stayed up late, night after night typing on the computer, Roxy would stay by side. She was my ever-present ally steadfast in her companionship and loyalty. She has filled my life with great love and joy. To her I will be forever grateful.

TABLE OF CONTENTS

DEDICATION.....	3
ACKNOWLEDGEMENTS.....	4
LIST OF TABLES.....	8
LIST OF FIGURES.....	9
ABSTRACT.....	10
CHAPTER ONE – Introduction	
Overview.....	11
Statement of the Problem.....	16
Justification of the Study.....	17
Theoretical Rationale.....	18
Mother-Daughter Relationship.....	18
Feminist Consciousness.....	19
Self-Esteem.....	19
Purpose of the Study.....	20
Research Question.....	22
Research Hypotheses.....	22
Definition of Terms.....	22
Method.....	23
Limitations.....	24
Summary.....	24
CHAPTER TWO – A Review of the Literature	
Introduction.....	26
Mother-Daughter Relationship.....	27
Contemporary Psychoanalytic Theory/Identification.....	28
Social Learning Theory/Modeling.....	35
Feminist Theory/Self-in-relation.....	38
Feminist Consciousness.....	43
Self-Esteem.....	48
Summary.....	54
CHAPTER THREE – Research Methodology	
Target Population and Sample.....	56
Data Collection Procedures.....	57
Instrumentation.....	58
Demographic Survey.....	59
Assessment of Interpersonal Relations.....	59
Sexist Attitudes Toward Women Scale.....	60
Coopersmith Self-Esteem Inventory.....	62
Research Design.....	63
Path Analysis Diagram Key.....	64
Guiding Research Question.....	65

Research Hypotheses.....	65
Path Analysis Model.....	67
Data Analysis.....	68
Ethical Considerations.....	69
Limitations.....	69
Delimitations.....	70
CHAPTER FOUR-Analysis of Results	
Introduction.....	71
Sampling Procedures.....	71
Descriptive Data Results.....	73
Data Analysis for Research Hypotheses.....	79
Hypothesis 1.....	82
Hypothesis 2.....	82
Hypothesis 3.....	83
Further Analysis.....	84
CHAPTER FIVE-Discussion of the Results	
Rationale for the Study.....	88
Review of the Results.....	90
Hypothesis 1.....	90
Hypothesis 2.....	91
Hypothesis 3.....	92
Discussion of the Results.....	92
Limitations.....	94
Discussion of Additional Findings.....	96
Recommendation for Future Research.....	98
Implications and Summary of the Study.....	101
REFERENCES.....	105
APPENDICES.....	114

LIST OF TABLES

Table 4.1.	Participants by Age.....	74
Table 4.2	Participants by Race.....	75
Table 4.3	Participants' opinion of their Mother's belief about male/female equality.....	76
Table 4.4	Mother's Education Level	77
Table 4.5	AIR, SATWS, CSEI, Means and Standard Deviations.....	78
Table 4.6	AIR, SATWS, CSEI Means and Standard Deviations By Participants Education level.....	79
Table 4.7	Path Analyses Fit Measures.....	80
Table 4.8	All Hypotheses: Path Analysis Fit Indices.....	81
Table 4.9	Regression Weights Revealed through Path Analysis.....	84
Table 4.10	Multiple Regression Results for Self-esteem, Mother-Daughter Relationship, Mother's Education Level, Opinion, Mother's Work, and Feminist Consciousness.....	85
Table 4.11	Correlations among Self-esteem, Mother-daughter relationship, Mother's Level of Education Feminist Consciousness, Opinion, and Mother's Work.....	86
Table 5.1	Alternate path: Path Analysis Fit Indices.....	100

LIST OF FIGURES

Figure 3.1	Index: Path Analysis Diagram Key.....	64
Figure 3.2	Path Analysis Diagram.....	67
Figure 4.1	All Hypotheses: Path diagram.....	81
Figure 5.1	Alternate Path Analysis Model	99

Abstract

The purpose of this study was to investigate the relationship between the perception of the mother-daughter relationship, feminist consciousness and self-esteem in the adolescent/ young adult daughter. The professional literature suggests that young women are struggling in unique ways concerning self-esteem and identity development in contemporary society. Women's development has been subsumed under the label of human development which is currently andocentric. Female development may require special attention. The professional literature also suggests that the mother-daughter relationship has tremendous influence on many aspects of growing daughters. Given this support, this studies aim was to investigate the contribution of the mother-daughter relationship on the self-esteem and feminist consciousness of daughters. In order to determine the effect of the mother-daughter relationship on self-esteem and feminist consciousness, 153 participants ages 17 to 19 enrolled in high school and college were given three measures: the Assessment of interpersonal Relations to measure the mother-daughter relationship, Coopersmith Self-esteem Inventory, self-esteem and the Sexist Attitudes Toward Women Scale, to assess feminist consciousness. Path analysis was used to analyze the data.

The findings did not support the hypothesis for this study. The use of path analysis revealed that the model did not fit the data and therefore did not support the theory set forth in this study. Further analysis using multiple regression and product moment correlation revealed significant correlational relationships. Implications of the finding and suggestions for further research were discussed.

CHAPTER ONE

Introduction

The topic under investigation in this study is the relationship between the perception of the mother-daughter relationship, feminist consciousness, and self-esteem in the adolescent/young adult daughter. This chapter provides an overview of the mother-daughter relationship with its unique characteristics and influences on the developing daughter and of the pertinent issues related to this topic, including the specific problems that face young women in a contemporary, patriarchal society. The importance of investigating feminist consciousness and self-esteem in this particular population is also discussed. Additionally, the theoretical rationale for studying the mother-daughter relationship, feminist consciousness, and self-esteem are explored. Ways in which this research is relevant to the field of counseling and can be used to inform counselors and counselor educators are discussed as well. Chapter two offers a selected review of relevant literature, while chapter three describes the research design for the study. Chapter four reports the results of the current inquiry, and chapter five presents the implications of the results, limitations of the study, and suggestions for future research.

Overview

Since the great liberation movements of the 1960's and early 1970's, known as the second wave of feminism in conjunction with the civil rights movement, women's lives have become highly complex. More interest has been generated in the domain of social sciences with the intent to gain a comprehensive understanding of women's lives than ever before (Henwood & Coughlan, 1993). Assumptions have been made that women's lives and development should have been greatly improved as a result of these transformative movements, yet according to Fine

(1992), feminism appears to have only modestly transformed psychology, social science research, and women's circumstances. Although feminism has affected women's consciousness, the traditional division of domestic labor, the organization of paid work, and the national distribution of wealth, income, and poverty remains relatively untouched (Fine, 1992). Therefore, adding to our understanding of women's development by exploring women's experiences, feminist consciousness, and influences on their sense of self by utilizing research is timely.

In her prominent and influential writing about motherhood, Adrienne Rich (1976) termed the mother-daughter relationship as the "great unwritten story" (Rich, 1976, p.276). Prior to the 1970's, the relationship had been scantily documented then became a relevant issue in feminist research and more recently has become the focus of linkages among mother-daughter connection, female power, and social change (O'Reilly & Abbey, 2000). Until recently, the mother-daughter relationship was viewed as highly conflictive due to unresolved issues arising from the lack of psychological differentiation and separation of the daughter from the mother (Pipher, 1994; Stern, 1990). The theoretical constructs of enmeshment and dependence have been used to explain the intensity and influence of the mother-daughter relationship on women throughout their lifetimes (Boyd, 1989).

However, a close examination of the ways in which women negotiate and construct their relationships and identities through nurturance, care, and self-in-relation may lead to an increase in the range of understanding available for women to make sense of their everyday lives (Jordan, Kaplan, Miller, Stiver & Surrey, 1991; Thomas & Daubman, 2001). In her very early and powerful writing, Jane Flax (1978) theorizes that the mother-daughter relationship may be a metaphor for women to better understand themselves and their development. The connection in

the relationship may help women to negotiate their need for both nurturance and autonomy which can serve as a guide for breaking free from the bonds of patriarchy and second class citizenry (Flax, 1978; Goldberg, 1995).

The mother-daughter relationship consists of many unique aspects that set it apart from other familial relationships (Boyd, 1989). These distinct characteristics set the stage for the relationship to be highly influential on the growing daughter. It is difficult to examine the mother-daughter relationship without attending to the specific issues and influences that impact the development of the daughter. An exploration of the characteristics of the mother-daughter affiliation and the specific issues and influences of the mother on the daughter provides an understanding of the relationship and the impetus to investigate this particular relationship.

The mother-daughter relationship is the first completely female relationship encountered by most women. A woman's first experience with nourishment, tenderness, and security comes from her mother. Mothers and daughters are connected in a special bond which transmits all that is female between two similar bodies, one of which has spent nine months inside the other (Rich, 1976). This relationship is not only highly substantial for women's identities; it connects issues of identity essentially with those concerning women's development and health (Henwood, 1997). The mother-daughter relationship can be viewed as symbolic for women's relationships in general in that the mother, due to internalized sexism, may lack power and may exhibit less esteem for herself and other women, therefore, modeling an aspect of not valuing the female or female relationship. Analyzing the problems inherent in the mother-daughter relationship renders useful an understanding of both feminist consciousness and the everyday activity of valuing relationships among women (Flax, 1978). Although this alliance has been portrayed as wrought with intensity and conflict, evidence exists to show the value and influence of the connection of

the mother-daughter relationship on the daughter's sense of self (Baruch & Barnett, 1983; Sholomskas & Axelrod, 1986) and her feminist consciousness (Buysse, 1999; Flax, 1978; Smith & Self, 1980; Weeks, Wise & Duncan, 1984).

The existing collection of research on the mother-daughter relationship, although admittedly dated, examines employment and careers, self-concept and identification, sex-role behaviors and attitudes, transitions, conflict and culture (Boyd, 1989). Broad insights from these studies indicate that the adult mother-daughter relationship is mutual, interdependent, close, and rewarding (Baruch & Barnett, 1983; Fischer, 1986). Conflicts arising during daughters' adolescence may be attributed to difficulties in individuation and separation that require new models for female development (Charles, Frank, Jacobson & Grossman, 2001). As daughters age and assume new roles that may include wife and mother, the relationship moves through several transitions and the conflicts of adolescent give way to reports of increased closeness and mutuality (Baruch & Barnett, 1983; Fischer, 1986). Also, despite conflict in the relationship, a higher concordance between mothers and daughters than other familial relationships has been documented (Peterson & Roberts, 2003). Studies with daughters who are college-age and younger show that mothers are influential in forming their daughters' attitudes toward work, career and sex (Smith & Self, 1980; Buysse, 1999).

Although these studies are significant, very little research about mothers and daughters has been directed at the testing of hypotheses derived from theory. Research indicates that the relationship is close and interdependent, but there is little empirical evidence to support Gilligan's (1982) concept that women's reality, which is based on connection to others, finds its roots within the mother-daughter relationship. The theoretical distinction between same-sex identification and modeling is difficult to assess unless "meaning" is examined in the studies.

Some theorists held that the relationship is too close and possibly destructive (Chodorow, 1978) while others emphasized the positive attributes of identification, affiliation, and attachment that characterize the relationship (Baruch & Barnett, 1983; Fischer, 1981). Theory-based research is needed to advance the understanding of the normative contemporary mother-daughter relationships and the role they play in the social and psychological development of women and mothers as well as the role they play in family structures and functioning (Boyd, 1989).

Substantiation of the effect of the mother on the daughter has been done using the mother-daughter dyad or solely the daughter's perceptions of the relationship with correlation of attitudes or beliefs between mother and daughter (Meier, 1972; Notar & McDaniel, 1986; Sholomskas & Axelrod, 1986; Smith & Self, 1980). The literature supports the notion that daughters' psychological well-being is significantly correlated with maternal rapport (Baruch & Barnett, 1983; Goldberg, 1995) and mothers who acknowledge, support, and show interest in their daughters' ideas and perspectives, have daughters with higher scores of psychological well-being (Sholomskas & Axelrod, 1986).

Feminist perspectives influence beliefs concerning women and particularly their relative social status as it compares to men. Assimilating these views involves questioning the status quo of women in society and can shape women's lives. This feminist consciousness viewpoint, "that women have a lower social status than do men and that the deficit in status and power is unjust or illegitimate" (Henderson-King & Stewart, 1997 p.9) may begin to change a woman's opinion of the appropriate roles of women in society. This in turn may bring rise to personal power and growth as new possibilities and potentials in the self and other women are discovered (Bartky, 1975). Within the mother-daughter relationship these attitudes are highly influenced in daughters by their mothers (Buysse, 1999; Meier, 1972; Smith & Self, 1980; Weeks, et al, 1984).

The unique aspects that make the mother-daughter relationship different set it apart from all other familial relationships and are revealed through its dynamics and influences. Due to the intensity and closeness of the relationship there is a great influence on the daughter from the mother and through the relationship. The inherent power of this completely female relationship within our contemporary society gives it salience when examining its affect on the developing daughter.

Statement of the Problem

Adolescent girls, as a group, struggle in various ways (Debold, Wilson & Malave, 1993; Pipher, 1994). They suffer from more depression, disturbances about appearance, eating disorders, stress and other psychological distress than adolescent boys (Debold et al.). Studies show that as girls progress through adolescence, their IQ scores regress, their math and science scores plunge, they lose resiliency and optimism, and they become less curious and inclined to take risks. Adolescent girls lose their assertive, energetic personalities and become more deferential, self-critical, and depressed. Girls report lower self-esteem and great unhappiness with their bodies than do boys (Pipher, 1994). According to a study conducted by the American Association of University Women (1990), girls at ages 8-9 are “confident, assertive, and feel authoritative about themselves”; about 60% reported they were, “happy the way I am,” as compared to 67% of boys the same age. Yet by age 16 only 29% of girls surveyed said they were “happy they way I am,” as compared to 50 percent of boys. Researchers concluded that although both boys and girls experienced a loss in self-esteem, the loss is more dramatic for girls (Eagle & Coleman, 1993).

In adolescence, daughters are thrust into a subculture of beauty that is perpetuated by patriarchal socialization. Girls grapple with difficult issues such as power, violence, economics,

sexual attraction, class, race, and individuation. The outcomes of these struggles serve to shape their identities as women in an environment of conflicting messages, competition, and loneliness (Debold et al., 1993; Pipher, 1994).

Justification for the Study

According to Goldberg, (1995), newer theories regarding women point to the impact of the mother-daughter relationship on the psychological development of women as significant. The more recent theories suggest that mutuality, or the process of reciprocity exists between mothers and daughters and that this process is positively associated with daughter's sense of self. Mutuality is a key concept in the mother-daughter relationship and in the development of a woman's self esteem (Chodorow, 1978; Gilligan, 1982; Rich, 1990).

Although studies have explored the mother-daughter relationship, many are not theoretically based. The present study based on theoretical constructs will use a causal research design which strives to substantiate the strength of the effect of the relationship of daughters' perceptions of the mother-daughter relationship on her feminist consciousness and self-esteem as well as the relationship between daughters' feminist consciousness and self-esteem and the effects of feminist consciousness on the perception of the relationship. It is hoped that the research will yield data which will clarify the nature of the influence of the mother-daughter relationship and suggest directions for future research that promote healthy development and self-esteem in young women.

The self-esteem of young women affects many aspects of their lives. The mother-daughter relationship and feminist consciousness are two components that, according to research, influence the self-esteem of young women. A comprehensive theoretical model is important to ground this study in order to provide an understanding of how these constructs interconnect.

Therefore, the following section will specifically examine the theoretical underpinnings of the mother-daughter relationship, feminist consciousness, and self-esteem.

Theoretical Rationale

Mother-Daughter Relationship

Three tenets of contemporary theories, one based in psychoanalysis, one in social learning theory, and the last in feminist theory, partially explain why girls become like their mothers and why the relationship is so intense, influential, and misunderstood. Contemporary psychoanalytic theory tends to emphasize unconscious internalizations of maternal behaviors and values, better known as identification (Chodorow, 1978; Buysse, 1999), while social learning theorists maintain that socialization which impresses modeling is the reason girls are so connected and like their mothers (Boyd, 1989). Feminist theory looks at how the relationship is unique and credits the connection with influencing gender role socialization within the context of our contemporary patriarchal society (Baruch, 1976; Gilligan, 1982). The attachment of the daughter to her mother is seen as the mechanism for female development (Josselson, 1987; Walters, Carter, Papp & Silverstien, 1988).

Theories attempting to elucidate the mother-daughter relationship place emphasis on the identity formation of the daughter as it pertains to identification with and socialization by the mother, as well as issues of affiliation and separation (Boyd, 1989; Buysse, 1999; Chodorow, 1978; Goldberg, 1995; Josselson, 1987; Walters, Carter, Papp & Silverstein, 1988).

Contemporary psychoanalytic theory, social learning theory, and feminist theory endeavor to explain why this relationship is different and unique from other familial relationships in intensity, longevity, and influence. These theories and underlying tenets base the present study in the solid foundation that the relationship is exceptional and worthy of study, particularly in the

investigation of how the daughter is influenced by the relationship with regard to her self-esteem and feminist consciousness.

Feminist Consciousness

Feminist consciousness is a particular set of beliefs concerning the social status of women as compared to men arising from awareness of one's status and power in society that is based primarily on gender. Such beliefs evolve over time and may vary from woman to woman (Henderson-King & Stewart, 1997). A daughter's feminist consciousness, how she perceives women in the world, allows her to recognize sexism (Bartky, 1975; Goodrich, 1991; Moradi & Subich, 2002). This, in turn, provides her with a sense of externalizing sexism as a product of the patriarchy rather than as the unconscious internalizations of a personal flaw due to gender: that of being female (Buysse, 1999; Moradi & Subich, 2002). By creating a positive relationship with their daughters, mothers provide an opportunity for them to value women. Mothers may treasure their daughters and pass on their worth through their attitudes which limit the power of internalized sexism.

Self-Esteem

Self-esteem is an interactive environmental-behavioral construct that is organized according to behavioral, cognitive, and affective principles (Bracken, 1993). It is a mental framework that allows an individual to organize how she thinks and feels about herself and the behaviors chosen to respond to the environment based on those beliefs (Coopersmith, 1967). Thus, the individual's attitude of herself regulates the thoughts and behaviors deemed comfortable and appropriate in the social context of the world of work, school, and leisure. Self-esteem is comprised of messages that an individual receives from society, particularly through significant relationships

with others that are then internalized and adopted as a part of how she sees herself (Blascovich & Tomaka, 1991).

According to Pipher (1994) “today’s girls come of age in a dangerous, sexualized, media saturated culture” (p.12) which pressures girls to become separated from who they really are and become a self that is acceptable to contemporary society. Papp (2003) asserts that it is not possible to separate one’s identity as male or female from self-image. The self exists in relational and social contexts and gender norms that stipulate how we act as men and women deeply influence this context. It can be damaging to one’s view of oneself as competent and worthy, which is indicative of healthy self-esteem, if one fails to live up to these societal expectations (Papp, 2003). Thus, girls are under a great deal of pressure to be sophisticated at a very early age which may result in risky behaviors and loss of their true selves (Pipher, 1994). Family is an important factor that influences and shapes a girl’s life; therefore, social and familial gender messages that demean women or lead to negative sex-role image may impact self-esteem (Eagle & Coleman, 1993).

Purpose of the Study

The purpose of this study was to examine the relationship between the adolescent/young adult daughters’ perceptions of the mother-daughter relationship, her feminist consciousness, and her self-esteem. The intention of investigating these principles was to promote an understanding of female development, feminist consciousness and self-esteem; to better understand the dynamics of the mother-daughter relationship in relation to these constructs and its effect on daughters.

For the purpose of this study, adolescent/young adult daughter will be defined as a young woman between the ages of seventeen and nineteen. The mother-daughter relationship is

significant to the context and foundation of the theoretical perspectives, proposing a strong influence of this relationship in a woman's life and connection to her sense of self as a woman (Chodorow, 1978; Goldberg, 1995). Feminist consciousness creates a context for perceiving the world in a radically different way, to recognize that social reality is deceptive, to recognize sexism and to externalize it as a product of the patriarchal culture rather than unconsciously internalize it as a personal flaw due to gender (Bartky, 1975; Sanford & Donovan, 1984; Smith, 1999). Self-esteem is defined as the way an individual regards herself. It is an internalized attitude or belief about oneself as a human being which provides a mental framework that prepares the individual to respond to the environment according to expectations of success, acceptance, and personal strength (Blascovich & Tomaka, 1991; Bracken 1993; Coopersmith, 1967; Moradi & Subich, 2002).

The purpose of counseling is to focus on the growth and development of the client rather than on pathology (Wastell, 1996). Recognizing the dynamics that positively influence the self-esteem of young women could extend counselors' knowledge of normative development in young women. This may lead to preventative interventions which could reduce risk factors and increase protective factors. Protective factors such as healthy self-image emphasize personal and social competence leading to adaptive outcomes. Efforts to help girls develop a positive attitude about who they are would be beneficial in strengthening self-esteem (LeCroy & Daley, 2001). This information also allows counselors to understand the dynamics of the mother-daughter relationship more clearly and to guide women toward an understanding of their development through recognizing the influence of this relationship on the daughters' self-esteem. This information could also provide women an avenue to discover a sense of self in order to enhance

self-esteem through exploring their relationships with their mothers in a healthy and productive manner.

Guiding Research Question

The primary research question that guided this study was: What relationship exists between daughters' perceptions of the mother-daughter relationship, feminist consciousness, and self-esteem?

Research Questions

This study will attempt to show direct causal relationships and the strengths of those relationships using a path analysis model. The expected outcome will be that predictive, causal, and correlational relationships will exist between the variables. Research hypotheses, using path analysis, are created from the theoretical constructs. Each hypothesis is stated separately while the model represents all the hypotheses in one diagram. The intention is for the path analysis model to fit the data. The purpose of the current study was to answer the following questions:

1. Does the daughter's feminist consciousness positively influence her level of self-esteem?
2. Does the daughter's perception of the mother-daughter relationship positively influence her feminist consciousness, and does her feminist consciousness positively influence her perception of the mother-daughter relationship?
3. Does the daughter's perception of the mother-daughter relationship positively influence her self-esteem?

Definitions of Terms

Adolescent/Young Adult Daughter- A female between seventeen and nineteen years of age attending high school or college.

Developmental- Describes the growth process that takes place in individuals over a lifetime.

Identification- This concept is part of the developmental process in psychoanalytic theory by which children learn sex-role behaviors (Corey, 1977). Identification is the idea that the individuals unconsciously transform interactions with their environment into inner regulations and characteristics by incorporating within themselves a mental picture of an object (person) and then thinks, feels and acts as they conceive the object (person) to think, feel and act.

Feminism- A set of beliefs, values, and attitudes that rest on the high valuation of women as human beings.

Feminist consciousness- A particular set of beliefs concerning the social status of women as compared to men arising from awareness of one's status and power in society that is based solely on gender (Henderson-King & Stewart, 1997).

Internalized oppression- A concept held that when an oppressed group of people believe the myths they maintain that oppression and carry the beliefs and actions to those within the group.

Mother- The primary, nurturing, female caretaker of children.

Patriarchy- A social society dominated by male supremacy and inequity between the treatment of men and women.

Socialization-The principle that learning takes place within a social context and that human beings learn from one another by observing behaviors modeled by others. Children imitate who and what they observe and are reinforced by positive attention for their behavior and attitudes.

Method

A predictive research design was employed for this study to determine the causal ordering of the variables to examine the relationship between a daughter's perception of the mother-daughter relationship, feminist consciousness, and self-esteem. The sample consisted of 153 young women ages 17-19 from two colleges and three high schools in the Northeastern and

South Atlantic United States. Data was collected in person by a liaison and through the mail utilizing the following instruments: a demographic survey, Assessment of Interpersonal Relations, mother subscale, Sexist Attitudes Toward Women Scale and the Coopersmith Self-esteem Inventory, adult version. Descriptive statistics and path analyses were used to describe the sample and determine the direction and magnitude of the relationship between the measures (Gall, Borg, & Gall, 1996).

Limitations

Participants in this study were characterized as volunteers and may not be representative of the target population. The employment of convenience sampling limited generalizability to the target population (Gall, Borg, & Gall, 1996). Participants who volunteered to complete the survey and assessment packet may have had significantly different characteristics than the non-respondent participants. Also, the assessments and demographic survey used in this study were subject to the limitations inherent in self-report measures, such as failing to understand the directions and/or dishonesty in a participant's response set.

Summary

The purpose of this study was to investigate the relationship between daughters' perceptions of the mother daughter relationship, feminist consciousness, and self-esteem. This chapter reviewed the current positions on the mother-daughter relationship and issues for girls and women in contemporary society in order to justify the need for this study. The theoretical underpinnings of the mother-daughter relationship, feminist consciousness and self-esteem were explored and utilized to examine the foundation for the framework of the study. A delineation of the research questions, methods, and definition of terms concluded the chapter.

Chapter Two features a review of the literature concerning the mother-daughter relationship, feminist consciousness, and self-esteem. Chapter Three examines the research methods employed in this study.

CHAPTER TWO

A Review of the Literature

Introduction

Daughters are found to identify first and most strongly with their mothers. The connection between a daughter's identification with her mother and her perception of the quality of that relationship and her self-concept is significant (Boyd, 1989). Attitudes of the mother about women and their place in society, their feminist consciousness, have a general positive effect on the mother-daughter relationship (Notar & McDaniel, 1986). In this relationship, the mother's feminist consciousness and her attitudes about sex roles directly affect the daughter's developing feminist attitudes (Buysse, 1999). A high level of feminist consciousness is purported to increase a woman's psychological well-being (Smith, 1999; Stein & Weston, 1982). Given these salient facts, this study explores the relationship among daughters' perception of the mother-daughter relationship, daughters' feminist consciousness, and self-esteem.

The literature review which follows contains three distinct sections. The first section reviews and compares the mother-daughter relationship from three perspectives: contemporary psychoanalytic theory, social learning theory, and feminist theory. The second section investigates and defines the term feminist consciousness, and the third defines and explores the construct of self-esteem as it pertains to the psychological well being of the daughter. Each section will examine the theoretical framework that provides a foundation for the study and the empirical data that supports those underpinnings. The critiques of the research studies include: the purpose of the study, a brief description of the participants, sampling procedures, and data collection instruments, the researcher's findings and conclusions based on data analysis, and the possible limitations and potential contributions of the study. The theory and research of the

mother-daughter relationship are explored taking into account the influences, attitudes, and conflicts of the relationship within the lifespan, as well as feminist and mothering research.

The first segment of this section will review the literature that explores the mother-daughter relationship according to each of the theoretical underpinnings, identification, modeling, and self-in-relation. Later segments will discuss the constructs of feminist consciousness and self-esteem.

The Mother-Daughter Relationship

The influence and intensity of the mother-daughter relationship has been explained through three theoretical underpinnings from three separate psychological theories. Contemporary psychoanalytic theory uses the concept of identification to explain why girls become like and connected to their mothers, to a greater degree than any other familial relationship. Identification emphasizes unconscious internalizations of maternal behaviors and values. In contrast, social learning theory highlights modeling as an avenue that explains learning and how children are influenced by those around them to think and behave in particular ways. The concept of modeling suggests that children's imitation of whom and what they observe is reinforced by positive attention for specific behaviors and attitudes. Lastly, a strand of feminist theory, self-in-relation, purports that girls relate more strongly to their mothers because they need connection and caring in ways that are different from boys. Although other theoretical assumptions exist, this study will focus on these three distinct suppositions supported in the mother-daughter literature.

Contemporary Psychoanalytic Theory/Identification

Identification is part of the developmental process in psychoanalytic theory by which children learn sex-role behaviors (Corey, 1977). Identification is the idea that the individual unconsciously transforms interactions with her environment into inner regulations and characteristics. According to psychoanalytic theory, internalization of the relationship with the mother may influence the daughter to modify herself or her activity to resemble the mother. Identification is based on the concept of psychic structures and defenses of the mind that the daughter uses to internalize the object of her mother (Chodorow, 1978). This allows her to differentiate herself from the environment all the while identifying with the mother. This powerful mechanism accords daughters the opportunity to gain a sense of self which evolves through inner experiences of relationships. Females remain internally attached to their mothers through identification into adulthood in healthy, growth enhancing ways (Buysse, 1999). On the other hand, a son's identification with his mother is not continuous and the male offspring changes identification to the father or male figure to seek his identity. Due to the extended identification with the mother, daughters often see themselves more like their mothers than sons are like their fathers (Chodorow, 1978).

Prior to the activation of the second wave of feminism in the 1960's and 1970's "women's issues" were omitted or neglected in the field of social science (Henwood & Coughlan, 1993). At the time psychoanalytic theory provided the core explanations of the psychological development of girls and women. Psychoanalytic theory, when attempting to explain why girls become like their mothers, emphasizes unconscious internalizations of maternal behaviors and values (Boyd, 1989). Reproducing the social behavior of mothering in women is accomplished through identification and the internalization of nurturance and mothering daughters receive, and

although influenced by socialization, this reproduction was not hypothesized to be accomplished solely through imitation of behaviors, or socialization.

Chodorow (1978) contended that because a female's identification with her mother continues throughout life, women maintain certain portions of their primary relationship with their mothers. She held that mothers and daughters engage throughout their lives in personal identification due to the strong identification a daughter has to her mother because of shared gender and intense bonding early in life. Gilligan (1982) suggested that through their identification with their mothers, women learn to value the perpetuation of relationships and to define their self-concepts in the context of their relationships with others (Tolman, Diekmann & McCartney, 1989).

According to Buysse (1999), the traditional psychoanalytic theory sets the stage for a story fraught with loss, envy, betrayal, passivity, and secondary citizenship within a patriarchal culture. Only when the female child realizes she is "not" a male due to the lack of a penis, for which she blames her mother, does she then begin to identify as a female. The daughter then turns her attachment to the father in an act that prevents her from becoming homosexual.

Homosexuality and the daughter's development in relation to the same sex parent are absent from this theory. This heterosexual, androcentric viewpoint born of traditional Freudian theory, considers the male version of development and attachment as normal and the female version as inferior and lacking (Archer, 1992; Unger & Crawford, 1992). Although psychoanalytic theory provides a framework for the process of identification for understanding the mother-daughter relationship, it has been criticized for its failure to address race, culture, and context in its interpretations. Also, it has perpetuated an inferior status for women and the relationships of women by comparing them to male relationships and to what they are not (Buysse, 1999).

During the 1970's and continuing up to the late 1980's, a small but substantive surge in the empirical research of the mother-daughter relationship emerged. An increase in the interest of women's issues may have emerged due to a change in socio-political factors such as the women's and civil rights movements as well as cultural shifts in sexual behavior, reproduction, and women in the workforce. These studies were mainly focused on the influence of the mother on the daughter with regard to career, work orientation, sex-role attitudes, and attitudes toward equality for women. Studies conducted with younger girls dispelled some of the myths that surrounded the conflict of the mother-daughter relationship.

Later studies, which were encouraged by the earlier research and the changing social structure, were broader in scope and investigated the mother-daughter relationship in a variety of ways. These studies examined topics such as patterns of individuation and separation, the likeness of the social construction of narratives of mothers and daughters, sexist and feminist attitudes of the daughter, as well as the mother and the care-giving aspect of adult daughters as their mother's age (Allen & Walker, 1992). All of the studies contribute to the corpus of literature in a unique way and in general validated the importance, influence, and longevity of the mother-daughter bond.

Peterson and Roberts (2003) studied the relationship of gender on the parent-child dyad using language and other aspects of narratives. Two-hundred-thirty-five children ages 8 to 13 and their parents were interviewed and free recall narratives of the same event were used to measure correlations between each parent and child. Narratives were appraised by length, elaboration, cohesion, coherence, and contextual embeddedness, and these aspects were used to assess concordance among mothers and daughters, mothers and sons, fathers and daughters, and fathers and sons. Correlations with Bonferroni correction used to assess similarities between parent-

child dyads were reported. The results showed that that narratives were gender differentiated and those of older daughters and their mothers were highly similar in all five narrative properties. Correlations ranged from .66 to .77 with $p < .004$. In contrast, narratives of older daughters and their fathers were quite dissimilar, and the narratives of older sons were not similar to either parent. The data presented in this study suggests a strong degree of affective and linguistic closeness between mothers and daughters. Limitations of this study include a small sample size composed of all White participants and the fact that the child participants suffered an accident which brought them to the hospital. Finally, the fact that all of the interviewers were female could have affected the outcome. However, Chodorow (1978) maintains that children of both genders develop strong bonds with their mothers, but that due to the concept of identification, girls have a stronger bond and concordance with their mothers than boys do to their father. The findings of this study (Peterson & Roberts, 2003) are consistent with the theoretical predictions of same sex parent-child concordance.

A study by Sholomskas and Axelrod (1986) was based on assumptions that mothers who work provide a role model for their daughters and that maternal employment relates to daughter's role preferences. This study investigated the relationship of women's current role choices, role satisfaction, and self-esteem to their perceptions of their earlier relationships with their mothers and to their perceptions of their mother's role choice and role satisfaction. Roles in this study were characterized as career, non-career work, and homemaker. The sample was comprised of 67 married women with preschool children. Daughters were given a packet of surveys including the Coopersmith Self-Esteem Inventory (CSEI), a self-report questionnaire to obtain respondent's retrospective reports about their mother's primary role and role satisfaction, and the Children's Report of Parental Behavior Inventory (CRPBI) to assess the mother-daughter

relationship through the daughter's perception of her mother's parenting. Interviews were conducted within two weeks of the initial contact. Results obtained through coded data were concerned with why women chose their current roles. Daughters were asked about their own current role choices, role satisfaction, and surveys were returned at that time.

A multiple regression analysis was performed using women's primary role satisfaction as the criterion variable and their education as the covariate. The analysis revealed the women's perceptions of their relationship with their mother, as assessed by the CRPBI, to be the single most important factor associated with the woman's current satisfaction with their primary role $F(1, 61) = 6.77, p < .05$. This finding illustrated that daughter's primary role decision did not parallel those of their mothers but was related to their mother's messages to them. Further exploration revealed that the power of the mother's influence lies both in implicit and explicit messages, and that women's role choices were not directly related to perceptions of their mothers' parenting behavior. Therefore, the single most important factor associated with daughter's current satisfaction with primary role was her perception of her relationship with her mother. Correlations with the "love" scale of the CRPBI were positive ($r = .28, p < .05$). Therefore, the more love, acceptance, and warmth that were perceived by the adult daughter when characterizing the mother-daughter relationship, the greater the daughter's role satisfaction. Also, the main factor that contributed to daughter's self-esteem was the mother-daughter relationship as assessed by the CRPBI with scores of $F(1, 61) = 4.18, p < .05$.

Another important finding in this study points toward the daughter's identification with the mother. It appears that the mothers were not role models; daughters did not imitate their mothers' role choices but were influenced instead by the messages from the mother and the quality of their relationship. These findings support the theoretical assumptions surrounding identification as

well as the influence of the mother-daughter relationship on the daughter's sense of self.

Mother's attitudes toward and prizing of the daughter as shown through the magnitude of the daughter's perception of the relationship, reveal the daughter's higher role satisfaction and self-esteem. However, the participants were primarily upper and middle class married White women with preschool children, thus limiting the generalizations of the study's findings.

Weeks, Wise, and Duncan (1984) investigated the relationship between the sex-role attitudes of high school females, ages 16 to 18, and their mothers with regard to the daughter's career plan, the mother's career status, and the grandmother's career status. Sex-role attitudes were measured for both mothers and daughters using the Sex Role Attitudes Inventory which is a Likert-type scale with five subscales: politics, male-female differences, domestic relations, labor, and relations to men. The instrument has a reliability of Cronbach's Alpha of .72. Daughters completed a demographic survey indicating their future career plans. Mothers completed a demographic survey reporting current career status and their mothers' career status during their childhood years. Data was collected from 70 mother-daughter pairs.

There was a significant correlation between the sex-role attitude scores of mothers and daughters ($r = .41, p < .0007$). The subscales, politics, male/female differences, and domestic roles yielded significant correlations. However, no relationship could be established for daughter's career plans and mother's career status. The results indicate a significant relationship between mother's sex-role attitudes and adolescent sex-role attitudes that supersede the career status of the mother. This supports the notion that daughters' work orientations are in reality much too complex to be attributed simply to role modeling. The results of this study support the concept of identification with the mother rather than the socialization of role modeling and thus

imitation of the mother. The main limitation to the generalization of the results of this study is the lack of diversity of the participants.

Smith & Self (1980) examined the influence of maternal sex-role attitudes on the sex-role attitudes of young freshman, female college students. Participants included 74 pairs of mothers and daughters with daughters attending a medium-sized urban Southwestern University. A Sex Role Attitudinal Inventory created by the researchers was used to assess sex-role attitudes of mothers and daughters. This inventory was designed to cover a broad range of interests and attitudes including political and sexual equity, stereotypical beliefs about women, and relationships with men. Regression analysis revealed mother's attitudes to be more important predictors of daughters' attitudes than maternal characteristics such as age, marital status, education, and occupational status with a coefficient of $r = .342, p < .01$. College-educated mothers had more influence on their daughter's attitudes than non-college educated mothers with a coefficient of $r = .542, p < .01$.

Although education had an influence between groups the researchers explain, the effect of education may be due to more liberal attitudes in educated mothers. These liberal attitudes of the mothers were internalized by the daughters and then affect the daughter's sex role attitudes. Also, in spite of the results, there was a great deal of the variance in the daughter's sex-role attitudes that remains unexplained.

The ongoing identification of the daughter with the mother is one explanation of these results and encourages the investigation of the influence of the perception of the mother-daughter relationship on feminist consciousness which is linked to sex role attitudes. Limitations of this study include the homogeneous sample and the great deal of variance in the daughter's sex role attitudes that remains unexplained.

These studies support the influence of the developmental process in psychoanalytic theory called identification. Although it is difficult to completely separate the effects of modeling and identification, the strength and quality of the bond that describes the mother-daughter relationship appears to be well supported in these studies through identification.

Social Learning Theory/Modeling

Social learning theory suggests that learning takes place within a social context and that human beings learn from one another by observing behavior modeled by others (Bandura & McDonald, 1963). Children imitate who and what they observe and are reinforced by positive attention for their behavior and attitudes (Boyd, 1989). In both research and clinical literature the mother is viewed as the most important figure in the child's life for both sexes (Baruch & Barnett, 1983). From this sociological viewpoint, the high interaction of the mother with her children is conducive to a strong mother-child attachment and may model and reinforce appropriate sex-roles (Meier, 1972). Social learning theorists disregard the idea of unconscious identification and advocate the principles of modeling (Bandura & Kuper, 1964).

Research suggests that girls learn to be like their mothers because they are positively reinforced when they imitate mothering behaviors that are socially acceptable (Tolman, Diekmann & McCartney, 1989). According to a sociological perspective, the mother is the central role model for her daughter and often defines the meaning of femininity and womanhood. Usually the mother-daughter relationship is the longest lasting woman-to-woman relationship that the daughter experiences (Notar & McDaniel, 1986) and its influence may last across the lifespan of the daughter (Baruch & Barnett, 1983). The relationship can be rife with conflict, particularly during adolescence and may manifest the ambiguities and confusion about the social meaning of womanhood and motherhood within a patriarchal society. The social climate

pressures women in particular ways to chose roles and the mother as the major socializing agent has tremendous influence on the daughter's role choice (Sholomskas & Axlerod, 1986). Mothers, when socializing daughters, are caught in a paradox. According to Goodrich (1991):

The better you've done your job as prescribed for you as a mother, the more you've trained your daughter to fit into the patriarchy-that's the saddest part of it. That's the squeeze play or dilemma of it. The better you do, the better you've done the worse for your daughter-in one way. (p.71)

And yet to encourage daughters to separate and not conform means they don't fit in, which may be incredibly painful as well. In either case mothers are held responsible (Debold, Wilson, & Malave, 1993).

Meier (1972) argued that the mother-centeredness of the American family is responsible for the "excessively" strong mother-child attachment and that this is undesirable, particularly for males. He hypothesized that because women are the most dominant familial figure, influencing attitudinal levels in children would result in egalitarian attitudes toward social roles of women in general. From this viewpoint, the mother has greater dominance as the socializing agent and conveys an image of social competence that can be generalized to all women. Thus, modeling social status or liberation of her own and not of her husband, may encourage her children to regard women's or their mother's ambition and higher social status as right and just.

Meier's (1972) research examined the relationship between sex role attitudes of college youth to parental characteristics and socialization influences. Although admittedly dated, this study is included because it explicitly addresses sex-role socialization. The study mainly addressed the socialization of children by mothers and sex-role attitudes conveyed to children by mothers as well as the influence of mother's and father's education on those attitudes. Samples were drawn through systematic procedures from a university enrollment list and 219 students,

both male and female, participated in the study. The Feminine Social Equity Scale (FSE) was used to assess sex-role attitudes, and parental salience was indicated by responses to questions on an interview-questionnaire schedule. Parental salience was measured by asking students to think about their childhood through high school and reflect on which parent seemed to have been the most influential on the whole in shaping their attitudes and general outlook on life. A strategy of multivariate analysis was pursued in order to partition independent attribute effects. Results were analyzed in order to partition the effects of the three variables, student's sex, parental salience, and parents' level of education and were reported as mean weighted variations.

The mother's education level had an effect on her offspring's sex-role attitudes scores showing a mean weighted variation of 17.2, $p < .01$. There appeared to be virtually no relationship between father's education level and FSE scores, reporting a mean weighted variation of 7.5, $p = .14$. Also, the effects of mothers' education were stronger when the mother achieved higher levels of education than the father. Regardless of either parent's level of education, egalitarian sex role attitudes were shown to be associated with maternal salience in attitudinal socialization 13.5, $p < .02$. However, the effects of maternal attitudinal salience appeared unusually strong when the mother was college educated or when the father was not educated beyond high school. Mother's occupational history and students' scores on the FSE were positively associated with a mean weighted variation of 20.6, $p < .01$. Also, students whose mothers were employed in low prestige jobs scored lower on the FSE than students whose mothers held higher prestige jobs. Students with mothers who remained exclusively homemakers were shown to score lower on the FSE than students whose mothers worked for any length of time.

Results indicate that the mother role was considerably significant in shaping the attitudes of the children being studied. Two important dimensions of the mother role that were effective were the extent to which the mother predominated in the attitudinal socialization of her children, and the degree to which the mother exhibited attributes of social achievement in her own right. Limitations of this study included the possibility that social class based differences were obscured in the college based sample.

This study emphasized the socialization of children and supported the concepts of social learning theory. Mothers who model high social status and are the primary socializing agents for their children affect the sex role attitudes of their children. Parent education levels influence on children is supported by social learning theory. If a mother has a higher education level than the father, sex role attitudes may be more egalitarian.

Feminist Theory/Self-In-Relation

Feminist theory presents a way to view the unique aspects of female development and the mother-daughter relationship and considers how this relationship may differ from other dyadic relationships (Boyd, 1989). Feminism and feminist theory is a broad heading under which many theoretical tenets and positions are grouped. Self-in-relation involves an important paradigm shift in understanding human development and women's development in particular. Rather than emphasizing separation, the self-in-relation model recognizes the value of relationship as the basis for self-experience and development, predominantly for women (Charles, Frank, Jacobson & Grossman, 2001; Jordan, Kaplan, Miller, Stiver & Surrey, 1991). It assumes that all other aspects of self develop within this context. The socialization of gender roles, feminist consciousness, and attitudes are crucial aspects which influence how women see themselves within the context of contemporary society. These aspects of self may be highly influenced by

the self-in-relation model when theorizing the daughter in relation to the mother. According to Walters, Carter, Papp and Silverstein (1988),

Feminism is a humanistic framework or world view concerned with roles, rules, and functions that organize male-female interactions. Feminism seeks to include the experience of women in all formulations of human experience and to eliminate the dominance of male assumptions. Feminism does not blame individual men for the patriarchal social system that exists, but seeks to understand and change the socialization process that keeps men and women thinking and acting within a sexist, male-dominated framework. (p.17)

Maternal importance with respect to shaping the child's basic attitudes and outlook on life would result in a relatively egalitarian attitude toward the social roles of women in general. Yet according to the feminist framework, a patriarchal social system prevails which often seeks to exclude and suppress the experiences of women. Therefore, mothers who were socialized within and accept, consciously or unconsciously, the patriarchal social system may perpetuate sexism by imparting internalized sexist attitudes onto their daughters (Notar & McDaniels, 1986).

Within the mother-daughter bond, one feminist perspective, self-in-relation examines the development of females including requisite connectedness and caring as a path for growth which appears different than the path taken or required by males (Jordan, et al., 1991; Steiner-Adair, 1990). The male child, who early on differentiates from the mother and looks to identify with the father, has a more bounded sense of self (Buysse, 1999). Boys are more apt to differentiate due to less intense identification with the mother due to gender differences. Boys then try to achieve their identity through the more absent father, which disengages them from the mother-child relationship.

Girls, on the other hand, may process very differently from their brothers. In addition to identification and attachment with the mother, the vehicle for female development becomes relationship rather than separation (Miller, 1986). Therefore, the concepts of differentiation and

individuation may not be applicable to women. The push for girls to be independent and less engaged with their mothers may actually be detrimental and create conflict in the mother-daughter relationship which then appears to erupt in adolescence (Buysse, 1999; Charles, Frank, Jacobson & Grossman, 2001). This conflict is based on the assumption that separation is necessary to achieve autonomy and to produce strong individuals. For mothers and daughters this push for separation may cause the mother to undermine the daughter whose very “sense of self” is interwoven with her experience in relationships (Debold et al., 1983; Jordan, et al., 1991). Alternatively, mothers can maintain a strong yet differentiated connection with daughters, creating a ripe context for girls to develop their sense of self within the relationship.

Fischer (1981) used interviews to investigate daughters’ transitions to marriage and motherhood on the mother-daughter relationship. The researcher defined the relationship by transitions and looked specifically at marriage and motherhood as significant times for redefinition and renegotiation in terms of daughters’ relative statuses, their role perspectives, and their family structures. The sampling procedure was designed to obtain a cross-sectional comparison of daughters: married with children, married without children, and single. The sample consisted of 39 daughters and their mothers. This study was based on a modified family case study approach consisting of in-depth interviews and self-administered questionnaires completed by the daughters, the mother, and other family members. Mothers and daughters were asked to rate themselves and each other in terms of mothering ability on a scale from one to seven. Daughter’s marital/parental status was cross tabulated with the “balance” of the rating of each other, that is whether they see themselves as better, the other as better, or both as equal in terms of mothering ability. The central independent variable was the daughter’s marital/parental status. Interview questions also examined the externals of the present mother-daughter

relationship-- how often they talked, saw each other, and what they did for each other in order to discern whether the daughter's transition into motherhood affected their involvement in each others' lives. Geographical distance was included as a control variable, and the dependent variables in the analysis were characteristics of the relationship defined as symbolic and interactional.

Results of this study show that the daughter's marriage and motherhood led to a reordering of the mother-daughter relationship. According to the findings of this study, the connection between the pair was important to both the mother and the daughter throughout the lifespan, although daughters didn't necessarily like their sense of similarity with their mothers. Transitions to motherhood created a desire to continue the relationship and Fischer refers to this as the "developmental stake" of daughters. This study focuses on how motherhood makes the "developmental stakes" more convergent. According to Fischer, a role relational orientation from an interactional perspective can be used as a general approach to development for women.

The richness, length, stability, and intimacy of the mother-daughter bond provides a good system for studying the life cycle of a relationship and how women gain a "sense of themselves" within that relationship, creating a metaphor for other relationships women have in general and specifically with other women. This standpoint supports the model of self-in-relation which proposes that girls and women develop within affiliation and connection to others and specifically within the mother-daughter relationship (Stern, 1990; Goldberg, 1995; Jordan, et al., 1991).

Buysse (1999) conducted a study to examine the impact of the mother-daughter relationship on the development of daughters' feminist consciousness. The inquiry surveyed 93 women between the ages of 24 to 35 years of age with living mothers. The study used the Sexist

Attitudes Toward Women Scale, Modern Sexism Scale, the California Inventory for Family Assessment, and the Adjective checklist as well as limited interviews to measure feminist consciousness and the mother-daughter relationship with respect to mutuality, affiliation, and enmeshment. The three independent variables included seven scales measuring the mutuality between mother and daughter and identification with the mother and six scales measuring aspects of enmeshment between mother and daughter. Correlations were calculated between each of the independent variables and the dependent variable, feminist consciousness. A regression equation was calculated to assess the predicative power of the three variables combined. Buysse (1990) hypothesized that mother-daughter mutuality would be positively related to the daughter's feminist consciousness and enmeshment would negatively relate to the daughter's feminist consciousness. Mother-daughter mutuality correlated positively on two subscales, of time together $r = .27, p < .01$ and physical intimacy $r = .26, p < .02$ with daughter's feminist consciousness. In terms of enmeshment regarding the mother, the relationship was the opposite of what was expected. Positive correlation was found between enmeshment and daughter's feminist consciousness $r = .25, p < .02$.

According to Buysse (1999), the relationship between mother-daughter enmeshment and the daughter's feminist consciousness scores could be due to the daughter reacting to a possessive, overbearing and less feminist mother, however; mother and daughter's feminist consciousness was highly correlated as well $r = .43, p < .0001$.

These results suggest that the concept of enmeshment may need to be revisited and redefined. Enmeshment or fusion is often seen as pathological, yet two women engaged in an intense relationship may be cohesive and create a relationship of trust and safety that may promote growth in one or both individuals (Seems, 2001). Implications for the current study support the

tremendous influence of the relationship on the daughter and the need to clarify how that influence manifests in the developing daughter. Limitations of this study include the use of volunteers and a lack of diversity in the sample which makes it difficult to generalize to the population of mothers and daughters at large.

Three tenets of three distinct theories have been examined: identification, a concept from psychoanalytic theory, modeling, taken from social learning theory, and self-in-relation, extrapolated from one perspective of feminist theory. Each theory demonstrates support for the unique aspects of the mother-daughter relationship. Although these concepts are from three distinct psychological theories and supported in the literature, reviewing the research demonstrates the tendency for them to overlap, adding a level of difficulty to teasing out discrete instances of each unique theoretical assumption within the mother-daughter relationship.

Feminist consciousness

The construct of feminist consciousness is grounded in feminist theory. Feminism is the recognition of the inequalities that exist in society around issues of gender and the detection that the culture may not perceive women positively or give women the status they deserve (Smith, 1999). Feminism posits that women are of equal status with men and deserve the rights and privileges afforded by that status. These beliefs arise from dissatisfaction with one's status and power in society that is based solely on gender (Henderson-King & Stewart, 1997). Feminist consciousness entails believing that women as a group have been systematically oppressed and that deficits in position and power are unjust or unlawful.

There are many ways to define feminist consciousness which appears to be a fluid notion unique to each individual. Feminist theorists and researchers Stanley and Wise (1993) when considering feminist consciousness write,

The process of consciousness tends to be described in terms of a spectrum, going from beginning (false consciousness) to an end (true consciousness). But we prefer to think of the processes of consciousness in terms of a circle or spiral—there are no beginnings and no ends, merely a continual flow (p.123).

To have feminist consciousness is to recognize sexism and externalize it as a product of the patriarchal culture rather than unconsciously internalize it as a personal flaw due to gender. It is a new way to make sense of the world; to become conscious of victimization and to relish in new found possibilities (Buysse, 1999). Higher perceptions of sexism accompany a higher feminist consciousness and may make women suspicious of everyday events, yet there appears to be positive relations between feminist identity development attitudes and indicators of psychological adjustment. It appears that recognizing sexism may protect women against the distress associated with experiencing sexism, implying that higher feminist consciousness is healthy for women's psychological adjustment (Moradi & Subich, 2002).

When examining the studies that investigate feminist consciousness, it is important to be cognizant of the 30 year time span of the studies from 1972 to 2002. Earlier studies exploring this construct used the terms sex-role attitudes, attitudes toward social equality for women, and feminist attitudes, while more recent studies use the terms gender role attitudes, feminist identity, and feminist consciousness. For the purposes of this review, all studies regarding the attitudes toward women and their gender roles in society come under the heading of feminist consciousness. Literature discussed earlier in this section will not be reviewed in depth but results and implications will be discussed.

As discussed earlier, Meier (1972) reported that independent of either parent's level of education, relatively egalitarian sex role attitudes are shown to be associated with the mother's sex role attitudes for all students. However females had higher sex-role attitudes scores than

males. Also, the effects of maternal sex role attitudes appear unusually strong when the mother was college educated or when the father was not educated beyond high school. Smith and Self (1980) reported in their study that mother's sex role attitudes are more important predictors of daughter's sex role attitudes than other maternal characteristic such as age, marital status, education, and occupational status. For mothers who were college educated, their education was a significant predictor of daughter's attitudes but this was not true for non-college educated mothers. Although education had an effect, mother's attitudes were still the highest producer of daughter's sex-role attitudes. Weeks et al., (1984) found that the daughter's sex-role attitudes, as measured by the Sex Roles Attitude Inventory were significantly related to their mother's attitudes toward sex roles, and Buysse (1999) found that within the mother daughter relationship the mother's feminist consciousness was positively related to the daughter's feminist consciousness. These studies all show a significant impact of mother's feminist consciousness on her daughter's feminist consciousness thereby supporting the tremendous influence that is available in the mother-daughter relationship on the beliefs of the daughter about how women should make sense of themselves as women in a patriarchal society.

In a study of 102 university aged women, Notar and McDaniel (1986) examined the adolescent/young adult daughter's perception of the mother and daughter relationship and whether feminism influenced these perceptions in a positive or negative manner. Most respondents were 19 or 20 years of age. Data was collected by the use of questionnaires: The Attitudes Toward Women Scale devised by Spence and Helmreich (1972), Beere's scale on women's issues (1973), and Carney and McMahon's social psychological scale (1979). Results were tabulated by percentage of agreement and disagreement between mothers and daughters on pertinent issues of domestic roles, employment, childrearing, marriage, sexual behavior, dating,

and women's rights. Among the feminist statements was the strong agreement between mother's perceived views and daughter's views on issues of freedom of employment for women, 96.2%, shared parenting, 94%, and marriage as an option rather than a priority for women, 76.5%. The issues on which there was less agreement were issues of sexual intimacy.

When asked about the quality of their relationships with their mothers, over half (53.9%) of the daughters claimed to have very good relationships with an additional 36% claiming good relationships. Women's issues were reported as being discussed in 77% of relationships. Good communication, ease of confidence, a sense of closeness, and listening ability were cited by daughters as factors contributing to a good relationship. The poor or fair relationships reported, 9.8%, disclosed poor communication and daughter's independence as problems.

When asked how often and in what areas they and their mothers discuss women's issues, 77% of the respondents reported that women's issues were a topic of conversation. A statistically significant relationship ($X^2= 39.5$, $df = 28$, $p = .07$) was found between not discussing women's issues and poor mother-daughter communication. Effects of feminism on the rating of very good and good mother daughter relationships were positive for 22% of respondents with 56% reporting no noticeable effects. Findings suggest that there is support that discussing women's issues in the mother-daughter relationship, thus feminism showed a positive effect on the mother-daughter relationships for some subjects in this study.

Although the outcomes of the study were not precise, the researchers (Notar & McDaniels, 1986) found that "the majority of daughters who have good relationships with their mothers see both themselves and their mothers as feminists although the daughters do not attribute their good relationships to feminism alone" (p. 20). Daughters who claim to have poor relationships with their mothers attribute their problems to feminism: the mothers are not feminists. Daughters are

unhappy with their mothers trying to influence them into traditional roles and their disagreements about sexuality and freedom may be attributed to internalized oppression (Debold et al. 1993).

Limitations of this study include a small nonrandom sample taken from a university population. Also, it is possible that the strong feminist agreement reported here between mother and daughter could be in part the result of daughters socializing mothers to new attitudes about women. Regardless, this study supports a need to further examine how the relationship affects feminist consciousness and how feminist consciousness affects the mother-daughter relationship.

Smith (1999) conducted a study which sought to examine the gender collective self-esteem of self-labeled feminists and anti-feminists. The sample was comprised of 232 women from a mid-sized Midwestern University as part of a requirement for General Psychology. Most of the participants reported themselves White. Participants were asked to complete a written questionnaire on their self rating as a feminist, collective self-esteem was measured using the sixteen item Collective Self-Esteem measure by Luhtanen and Crocker (1992) using four subscales. The four subscales consist of Private, Public, Membership, and Identity. Reliability for these scales ranged from .68 to .70. The Sexist Attitudes Toward Women Scale developed by Benson and Vincent (1980) was used was used to examine attitudes toward women. An ANOVA statistic was used to test overall gender CSE for feminist, anti-feminist, and mixed. The results were significant, $F(2,227) = 5.40, p < .01$. A Scheffe's test was performed to test for group differences and results showed that feminist and anti-feminists did not differ while participants who were mixed had lower overall CSE scores. Also, using a one-way ANOVA for the three feminist categories showed significance, $F(2,227) = 5.34, p < .01$, which revealed that feminists had higher means on the Private subscale, measuring one's own judgments about the goodness of

one's gender group on the CSE than any other group. This finding indicates that feminists may increase personal positive judgments about being a woman.

The analyses revealed that feminists and anti-feminist both consider gender as being important to self-concept. High gender collective self-esteem in anti-feminists might have been a result of their belief in traditional women's roles while a broad view of women's roles might have been related to gender collective self-esteem in feminists (Smith, 1999). Regardless, this study supported the notion that feminist consciousness does affect aspects of self-esteem.

Self-esteem

How an individual conceptualizes him or herself is known as self-esteem, self-concept, self-worth, self-image, and identity achievement (Bracken, 1993; Coopersmith, 1967; Harter, 1996; Stein & Weston, 1982). These concepts are used interchangeably, however; for the purpose of this study the term self-esteem will be used. Self-esteem is one of the dimensions of psychological well-being (Boyd, 1989; Charles, Frank, Jacobson & Grossman, 2001). Self-esteem refers to the internalized evaluation a person makes about him or herself, an attitude of approval or disapproval which indicates the extent to which a person believes she/he is capable, significant, successful, and worthy (Coopersmith, 1967). Self-esteem is an interactive environmental-behavior construct that is organized according to behavioral principles (Bracken, 1993) as well as cognitive and affective principles (Blascovich & Tomaka, 1991). Self-esteem provides a mental framework that prepares the individual to respond to the environment according to expectations of success, acceptance, and personal strength. Thus, an individual's attitude of him/herself regulates the thoughts and behaviors deemed comfortable and appropriate in the social context of the world of work, school, and personal leisure. Self-esteem is defined by

how an individual internally evaluates herself, an attitude of approval or disapproval which indicates the extent that a person believes she is capable, significant, successful, and worthy.

Self-esteem is developed through the interactions of the individual in the environment, including other people within that environment. If met with disdain, contempt, or harsh judgment by others, an individual will adopt or internalize that view (Bracken, 1993). Self-esteem is one of the dimensions of psychological well-being (Boyd, 1989; Charles et al. 2001).

Sanford and Donovan (1984), in interviews with women, found six self-esteem detractors that appear to be propelled by cultural norms in a patriarchal society. Due to women's second class citizenry and lack of apparent history, women do not possess sufficient knowledge of who they are. This lack makes it difficult to value and like what they do not know. Meeting the requirements of the culturally traditional feminine stereotypes, caring and nurturing for others is seen as being "a good woman," and yet these qualities are not highly valued in society. This paradox is limiting and highly undermines women's self-esteem as it plays a part in how women judge themselves within the culture. Traditional theories that define women by what they are not, male, leads to a deficiency in self-esteem that is based on not being male (Chodorow, 1978). Mothers, as central socializing agents, inculcate these values of the patriarchal society to their daughters, often in a state of unawareness. The self-esteem of a daughter who is socialized into secondary citizenship status is in question if the learned female role behaviors include: dependency, limited assertiveness, lowered achievement goals and lower self-confidence (Douglass, 1989).

Some studies of the mother-daughter relationship reflect the impact of the affiliation on the self-esteem of the daughter. Baruch and Barnett (1983) studied the effect of the mother-daughter relationship on the psychological well-being of adult daughters. The sample consisted of 171

women between the ages of 35-55 and was designed to include women in various role patterns. These roles included four family-status groups: never married, married with children, divorced with children. Six groups emerged to include those employed with high, medium and low prestige. The sample was not representative of the population of American women at large. Open-ended interviews lasting three to six hours were carried out as well as demographic surveys and measures of well-being using the Rosenberg self-esteem scale, the Pearlin mastery scale, and the anxiety and depressions subscales of the Hopkins Symptom checklist. Quantitative and qualitative analyses were used in this study. Significant but modest correlations were reported for the sample as whole between maternal-rapport index and two well-being factors, sense of mastery, $r = .19, p < .01$; for pleasure $r = .22, p < .01$. Analyses revealed that overall relationships between mothers and daughters were seen as rewarding particularly by women who were not themselves mothers. The psychological well-being of the daughter was significantly correlated with maternal rapport and daughters reported that even though they knew it wasn't fashionable, they liked their mothers.

These findings contradict the idea of the relationship being overwhelmingly conflicted, particularly as the daughter ages. It also revealed recognition of the potential for gratification of the role of daughter during the adult years. The main finding in regards to the present study concerns the influence of maternal rapport on the daughters' sense of well-being which subsumes self-esteem.

According to the study by Sholomskas and Axelrod (1986) which was reported previously, a multiple regression analysis controlling for women's education with self-esteem as the criterion variable showed the mother-daughter relationship as assessed by the Children's Report of Parental Behavior Inventory (CRPBI) scores to be the main factor contributing to women's self-

esteem $F(1,61) = 4.18, p < .05$. No significant effects were found for mothers' primary roles or for mothers' primary role satisfaction, nor were there interaction effects. Closer examination revealed that the scores on the hostility subscale contributed significantly to scores on the self-esteem scale ($r = -.33, p = .007$). Thus, the less hostility perceived by the daughter, the greater her self-esteem.

Also, the study by Smith, (1999), reported in the feminist consciousness section, revealed that feminists and anti-feminists both saw gender as being important to self-concept. High gender collective self-esteem in anti-feminists may be a result of their belief in traditional women's roles, while a broad view of women's roles may be related to gender collective self-esteem in feminists (Smith, 1999). Regardless, this study supports the notion that feminist consciousness does affect aspects of self-esteem.

Stein and Weston (1982) hypothesized that women who were more pro-feminist in their attitudes toward women's roles in contemporary society would score higher on measures of identity achievement than women whose attitudes were more traditional. A random sample of 300 college women students were asked to complete Spence and Helmrich's Attitudes Toward Women Scale (AWS) and Simmons' identity Achievement Scale. Identity achievement can be considered an aspect of psychological well-being and hence, self-esteem. The sample was separated into two groups using the scores on the AWS, as traditional and non-traditional. The difference between the groups was tested by a one-tailed t-test with $df = 294, t = 2.79, p < .01$. The hypothesis that non-traditional women would score higher on the Identity Achievement Scale was supported. Implications from this study involve the possibility that women with non-traditional views that conflict with societal norms need a strong sense of identity.

Sanchez and Crocker (2005) examined the relationship between investment in gender ideals, well being and the role of external contingencies of self-worth in college freshmen. Investment in gender ideals refers to the extent to which an individual believes it is important to be similar to the ideal for their gender and external contingencies of self-worth refers to self-esteem that requires external validation such as basing self-esteem on appearance or others' approval. The sample consisted of 343 female and 451 male college freshmen and data was collected at the beginning of freshmen year and then again at the beginning of second semester. Investment in gender ideals was measured using a two-item measure created by Wood, Christenson, Hebl and Rothberger (1997) and global self-esteem was measured using the Rosenberg Self-Esteem Inventory, depression was measured using the Epidemiological Studies Depression Scale, Disordered eating was measured using a nine items used and external contingencies of self-worth utilized the Contingencies of Self-Worth Scale. Structural equation modeling using Path analysis was utilized and the model was a good fit. External contingencies mediated the relationship between gender ideals and the outcome variables. Investment in gender ideals was positively associated with external contingencies and negatively associated with self-esteem in both males and females in this study. Therefore investment in traditional general ideals, which would be opposed to high feminist consciousness, persists as a negative predictor of well-being in early adulthood. This data infers the possibility that non-traditional gender ideals, more closely associated with feminist consciousness would positively affect well-being.

Thomas and Daubman (2001) explored the role that friendship quality may play in affecting self-esteem in adolescents. The sample consisted of one-hundred-sixty-four 11th and 12th graders, 97 female and 67 males; 95% of the students were white. Participants were administered the Coopersmith Self-Esteem Inventory, Adult Form to assess self-esteem, and Wright's

Acquaintance Description Form, Adolescent Version to measure friendship quality. Friendship quality was assessed twice, once with the individual's same gender best friend identified as the target person, and then again with individual's cross-gender best friend. Results first and foremost support other research findings and show gender differences in self-esteem for boys and girls. This study found boys had much higher self-esteem scores than girls with an effect size of .61 comparable to the effect size of the AAUW (1991) study. Other findings of this study indicate that girls' self-esteem was related to the quality of their friendships, $r = .21, p < .025$, but not for boys who participated in this study. The friendships that were significant were girls' relationships with boys, but girls also identified their friendships as stronger and interpersonally rewarding than boys who reported on friendships in the study. The researchers extrapolate that because girl's identity development is closely tied with interpersonal relationships (Chodorow, 1978; Gilligan, 1982; Jordan, et al., 1991), it makes sense that girls involved in strong, interpersonally rewarding relationships would have higher self-esteem. This study also addresses the issue of self-in-relation and the way girls find identity within the context of relationship in their lives.

These studies, though conducted with small populations and yielding modest results, reveal and acknowledge the influence of the gender roles ideals, attitudes toward women, the mother-daughter relationship and other relationships on the daughter through the construct of self-esteem. Self-esteem of adolescent girls appears to be influenced by various relationships. Mothers' attitudes and behaviors in the relationship relate to the daughter's sense of self and how the daughter "makes sense of herself" in the environment.

Summary

The research presented here validates the notion that the mother-daughter relationship is an influential and significant bond. Mothers are the centralizing socializing agent of their children, yet daughters are more like their mothers than sons are like their mothers or fathers. That mother and daughter concordance was higher than other familial relationships documented by research supports that the mothers' attitudes and the daughter's perceptions of the mother-daughter relationship affect daughter's attitudes and psychological well-being. That daughters highly identify with their mothers is well supported. There is also evidence that mothers are role models for their daughters. Studies support identification, socialization, and connection as ways that mothers influence their daughters.

Studies focused on the relationship aspect of the mother-daughter relationship advocate for a new understanding of the relationship. Connection was found to be important to both mothers and daughters throughout the lifespan and daughters enjoyed being with their mothers. Separation and individuation, if not supported by the mother were seen as creating conflict in the relationship. Terms such as individuation and enmeshment may need to be redefined and renegotiated to understand female development and the mother-daughter relationship. The majority of daughters who had good relationships with their mothers see both themselves and their mothers as feminists and daughters who have poor relationships with their mothers attribute the problems to feminism: their mothers are not feminists. Feminist thought and role socialization appear to create a better relationship for mothers and daughters.

Feminist consciousness appears to increase a woman's personal positive self-judgment about being a woman. The research greatly supports that the feminist consciousness of daughters is impacted highly by their mother's feminist consciousness or sex-role attitudes. Additionally,

there is some evidence that higher levels of feminist consciousness affect self-esteem. Self-esteem is also influenced by the mother-daughter relationship. Research supports that the psychological well-being of the daughter is significantly correlated with maternal rapport. Finally, mothers who supported their daughter's ideas and perspectives had daughters with higher levels of psychological well-being.

Research supports the following; the higher a woman's feminist consciousness, the higher her psychological adjustment and well-being; mother's sex role attitudes and feminist consciousness influence the adolescent and young adult daughter's sex role attitudes and feminist consciousness, respectively and, positive mother-daughter relationship as perceived by the daughter increases her sense of psychological well-being. Although these studies inform the literature on many aspects of the mother-daughter relationship, none of the studies explore the relationship of the daughters' perceptions of the mother-daughter relationship or feminist consciousness and self-esteem, which is the intent of the present inquiry.

Thus, the review of the literature provides clear justification for exploring the contributions of the mother-daughter relationship and feminist consciousness on the self-esteem of the daughter, while also exploring the association between the mother-daughter relationship and feminist consciousness. The use of a more sophisticated statistical analysis along with a model grounded in theory is a logical and suitable extension to supplement the current data found in the literature.

The following chapter presents the research design and methodology of the study. The population is described, data collection procedures explained, and instrumentation discussed. The research hypotheses are described and the data analysis is explicated.

CHAPTER THREE

Research Methodology

The purpose of this chapter is to describe the design and methodology used in the study. Following are descriptions of the target population and sample, data collection procedures, instrumentation, research design, research questions and hypotheses, data analysis procedures, ethical considerations, and limitations of the study. Finally, path analysis diagrams illustrating the modeling of the data are included in the research hypotheses section.

Target Population and Sample Description

The target population for this study was young adult and adolescent females in the United States, 17 to 19 years of age. The sample consisted of 153 adolescent young women who were daughters in a relationship with their mother or someone in the mother role. Ninety-nine participants were enrolled in two separate colleges, one a Southern Atlantic college, the other a Northeastern community college. Fifty-four participants were public high school students, twenty were from a mid-size urban Southern Atlantic high school, and twenty-two attended a small rural Northeastern high school. Twelve participants were students at a small, Catholic-affiliated Southern Atlantic private school.

Due to privacy issues protecting minor high school students, public institutions evidence hesitancy when allowing researchers access to high school students, so the use of random sampling was complicated. Therefore, in order to meet the needs of this study, a convenience sample of adolescent young women in two school districts, who were open to participating in research and one private high school, were accessed. One public school group was strictly from the senior family consumer science classes, while the other was recruited by the assistant

principal. At the private school, the school counselor approached students based on age and gender. Although the sample is not random, being selected from assorted high schools and colleges in various demographic areas increased the possibility that the target population is represented. A clear description of the sample provided by the researcher can support inference of the convenience sample to the population (Gall, Borg & Gall, 1996).

Data Collection Procedures

The data was collected in person, by the researcher or a liaison, and through the mail from May through November 2005. Each participant was given a survey packet containing: a consent form, a demographic survey, the Sexist Attitudes Toward Women Scale, the Coopersmith Self-Esteem Inventory, adult form, and the Assessment of Interpersonal Relations, mother subtest only. Packets sent by mail also included a self-addressed return envelope. A combination letter, consent form (Appendix A) was sent home with high school students to inform their parents about the nature of the study and to obtain their consent prior to their child's participation. All participants of the study were provided a consent form (Appendix B) that described the purpose of the study and required informed consent to participate in the study. Copies of the consent form were given to all individuals who participated in the study. The consent form served to inform each participant of the purpose and procedures involved in the study and as well as of her rights as participant. It explained the informed consent procedures as well as the procedures for the obtaining results of the study. The researcher's telephone number, address, and email were provided to participants if clarification or assistance was needed. Each packet of surveys was coded using four digit numbers so that names were not be used. Anonymity was of the utmost importance.

Participation was voluntary. All subjects were informed of their right to decline to participate or withdraw from the study at any time. Individuals were invited to participate in the study according to age and gender. At the Northeastern community college, a liaison in the counseling office invited students to participate in the study as they came in to register for classes. These students completed the surveys packets on site and returned them immediately. Registered students at the Southern Atlantic College were sent an e-mail letter in the Summer and Fall explaining the study and inviting them to e-mail the researcher if they were interested in participating. These students were also offered an incentive of three \$25.00 gift certificates won through a random drawing of all participants.

Public high school students were recruited in various ways. At the Northeastern high school students in the senior family consumer science class were asked to participate. The teacher incorporated the research concepts into a lesson, and the researcher is planning to visit the class in the Spring, 2006 to discuss the study's results. Students at the Southern Atlantic public high school were recruited by flyers or personally by the assistant principal, while students at the private school were recruited by the school counselor.

Instrumentation

Four instruments were used to collect data from participating daughters: a demographic survey, the Sexist Attitudes Toward Women Scale, the Coopersmith Self-Esteem Inventory, adult form, and the Assessment of Interpersonal Relations, mother subtest only. In addition to these, an informed consent document will be signed prior to any participation in the study. All measurement instruments were formatted into scanning documents using the Remark Office software (Appendices C, D, E, and F). The completed survey documents were then scored using a remark program with a scanning machine. This allowed the researcher direct computer access to

scoring and allowed straightforward visual recognition of problems such as multiple answers, incomplete surveys, and incorrect scoring. The goal of this process was served to lessen the tedium and reduce human error in the scoring, documentation, and presentation of the six-hundred and twelve total surveys equaling sixteen-thousand, six hundred and seventy-seven items.

Demographic Survey

The demographic survey was a one page questionnaire developed by the researcher. The questionnaire solicited respondents' general information about their age, ethnicity, mother's ethnicity, education and employment levels, and the length of the relationship. Additionally, daughters were asked if the person they refer to as mother is their biological mother, stepmother, foster mother, or guardian or caretaker. Daughters were also asked their opinion about their mother's belief in the idea that women and men should be treated equally politically, economically, and socially. This instrument was intended to identify demographic variables that could bear a relationship to the daughter's reports of her perception of the mother-daughter relationship, her feminist consciousness, and self-esteem.

Assessment of Interpersonal Relations

The Assessment of Interpersonal Relations developed by Bracken (1993) was used to assess the relationship between mothers and daughters. The AIR consists of three subscales: peer, parents, and teachers. Each subscale is composed of 35 questions. The parent subscale contains scales for the mother and the father. Each subscale can be administered and interpreted independently as a distinctive measure of that interpersonal relationship. For purposes of this study, the parent subscale for the mother, which has 35 questions, was administered. The mother subscale assesses students' perceptions of the nature and quality of the behaviors shared between

them and their mothers. Seven of the 35 items are negatively connoted and should be reversed in weight. The scores on the subscale range from 35-140, with a higher score being interpreted as perceiving the relationship more positively. The test and subscales are interpreted using norm referenced scores. The scores are compared to the standardization sample. The AIR was standardized on a sample of 2,501 children who ranged in age from 9 years to 19 years. The sample included children of both genders and all major ethnic groups. Significant deviations from the norm can be interpreted as less well or better adjusted than his or her “normal” peers. The AIR is a suitable measure to use in research when the goal is to study the association between interpersonal relations and other psychological variables as in the present study, self-esteem, and feminist consciousness (Bracken, 1993).

According to the review in the *Mental Measurement Yearbook* (1995) by Frederick J. Medway, Professor of Psychology, University of South Carolina, Columbia, SC, the AIR is easy to administer and score and is psychometrically sound. Test reliability estimates exceed .90 for each of the five subscales and the total relationship index and validity is strong for the instrument. This instrument was chosen for its strong psychometric properties, specific subscales, and efficient nature.

Sexist Attitudes Toward Women Scale

The Sexist Attitudes Toward Women Scale (SATWS), a 40 item scale developed by Benson and Vincent (1980), was used to assess feminist consciousness. The scale is designed to measure “attitudes which function to place females in a position of relative inferiority to males by limiting women’s social, economic, and psychological development” (Benson & Vincent, 1980). Twenty-four items are sexist statements and sixteen items are nonsexist and require reverse scoring. Scores on the scale are summed and range from 40 (very non-sexist) to 280 (very sexist). Also,

due to dated language, two items were reworded with permission from the publisher for the purposes of this study. The measure covers seven dimensions that are considered important aspects of sexism. The seven components are: women are genetically (biologically, emotionally, and intellectually) inferior to men, men should have greater rights and power than women, support for sex discrimination practices in education, work and politics is acceptable, women should not engage in traditional male roles and behaviors and should engage in traditional female roles and behaviors, the women's liberation movement should not be supported, derogatory labels and stereotypes are acceptable in describing women and it is acceptable to judge women based on their physical attractiveness (Benson & Vincent, 1980). These seven variables comprise attitudes that reflect the permissibility to treat women differently than men simply because of gender.

According to Henderson-King and Stewart (1997), feminist consciousness is a particular set of beliefs about the status of women as a group. Women are considered second class citizens within patriarchal societies simply because of gender, and the recognition that this is an unjust outcome of systematic oppression and can be changed, defines an individual's level of feminist consciousness. These beliefs are born from a woman's discontent with status and power in society based solely on gender and her understanding that men and women should be judged equally based on merit rather than gender bias. The Sexist Attitudes Towards Women Scale captures these beliefs, called sexist attitudes, and is used in this study to measure feminist consciousness.

Benson and Vincent (1980) found alphas ranging from .90 to .93 which show high internal consistency reliability. As evidence of its validity the SATWS strongly correlated on items of willingness to evaluate women based solely on attractiveness ($r = .68, p < .01$) and appreciation

of sexist humor ($r = .76, p < .01$) Buysse (1999) used the SATWS to assess daughter's feminist attitudes as well as a shortened version to appraise mother's feminist consciousness. Smith (1999) used the scale to determine feminist attitudes and its correlation to collective self-esteem.

Coopersmith Self-esteem Inventory

The Coopersmith Self-esteem Inventory is designed to measure self-esteem which is an individual's attitude toward self in social, academic, family, and personal areas of experience. The original inventory is a 58 item instrument and can be used with individuals 8 to 15 years of age. For persons 16 years and older, the adult form which utilizes 25 items and correlates .95 with longer version is used. Negative items are scored as correct if they have been answered "unlike me," while positive items are scored as correct when answered "like me." The scale is scored by adding the number of questions answered correctly and multiplying by 4 to create scores up to 100, with higher scores indicating higher self-esteem. This scale has been extensively validated through its use with individuals of all age groups. The inventory can be completed in 10 to 15 minutes, may be individually or group administered, and is appropriate for research studies (Bracken & Mills, 1994). Acceptable reliability and validity information exists for this self-esteem inventory (Blascovich & Tomaka, 1991).

According to reviews in the *Mental Measurements Yearbook* (1985), Christopher Peterson purports that the Coopersmith self-esteem inventories are reliable and stable, and there is much information to verify its construct validity. The measure is straightforward and easily administered and has been substantially supported in research as in comparison to clinical practice. Another reviewer, Trevor E. Sewell, states the reliability and validity data are as strong as they could be, and that the adult form has no validity and reliability data. Coopersmith (1967) contends that the adult form correlates with the longer version which has considerable data

supporting its validity and reliability. Sewell reports that the inventory is not recommended for individual clinical use but is applicable for research purposes and the scale is highly recommended for this purpose.

Research design

The purpose of this study was to examine the contribution of the daughter's perceptions of the mother-daughter relationship depicted by scores on the mother subscale of the Assessment of Interpersonal Relations, to their level of feminist consciousness, represented by scores on the Sexist Attitude Toward Women Scale, and self-esteem as indicated by the scores on the Coopersmith Self Esteem Inventory. It was also the purpose of this study to examine the relationship of feminist consciousness scores on the Sexist Attitude Toward Women Scale and self-esteem as indicated by the scores on the Coopersmith Self-esteem Inventory in young adult adolescent women.

A predictive research design was employed for this study to determine the causal ordering of the variables. Path analysis was used to test a hypothesized model. Path analysis is an extension of multiple regression which can be used to test theoretical hypotheses of causal order among a set of variables (Klem, 1995). Path analysis is concerned with estimating the strength of hypothesized relationships between variables and creating a model to fit the research data which would then support the theoretical hypotheses (Klem, 1995). The design consisted of path and correlational analyses. Correlational analysis between the demographic variables and the variables of the mother-daughter relationship, feminist consciousness, and self esteem of the daughter was also conducted.

Path analysis has the advantage over regression analysis of testing theoretical constructs in a causal framework using correlational data (Gall, Borg, & Gall, 1996). Further, path analysis

enables the researcher to examine the direct and indirect effects that one variable has on another (Asher, 1983). Therefore, it supports a more explicit causal approach in the search for understanding of the examined phenomenon, while providing an indication of the strength of theoretical constructs. In path analysis, theoretical constructs are displayed in a formal and explicit model that is presented both in a narrative and a path diagram form (Klem, 1995). Path diagrams display graphically the pattern of causal relations between variables. A path analysis diagram key is provided.

Path Analysis Diagram Key

Figure 3.1
Index: Path Analysis Diagram Key

Theoretical Construct

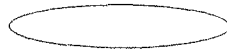

Measured Construct



Error

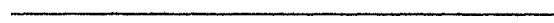
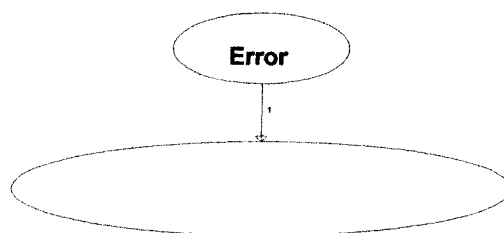

Line of Contribution/Influence



Guiding Research Question

What type of relationship exists between a daughter's report of her perception of her relationship with her mother and her feminist consciousness and self-esteem?

Research Hypotheses

The hypotheses will be visually depicted by a path analysis model. The model was depicted by the literature informing the reader about the relationships between the daughters' perceptions of the mother-daughter relationship with regard to feminist consciousness and self-esteem and was based on theory. It was hypothesized from the empirical data that the path analysis model shown would fit the data generated by the present study. The research informs the reader that the daughter's feminist consciousness is significantly related to mutuality in the mother-daughter relationship, particularly the mother's feminist consciousness, time spent together, and physical intimacy (Buysse, 1999), and a higher feminist consciousness, recognition of sexism, relates positively to psychological adjustment as well as self-regard and self-esteem among women (Stein & Weston, 1982; Moradi & Subich, 2002). Attitudes of the mother about women and their place in society and their feminist consciousness have a general positive effect on the mother-daughter relationship (Notar & McDaniel, 1986). There is a positive significant relationship between the daughter's identification with her mother and the daughter's self esteem (Baruch,

1976; Hollender, 1973). Self-esteem and gender-role satisfaction of the daughter were enhanced when the mother-daughter relationship was perceived as loving and accepting (Sholomskas & Axelrod, 1986). Although the relationships between these constructs are reasonably supported in the literature, no study has examined them together, or looked at the causal order or the magnitude of the relationships between constructs.

1. Hypothesis one: Feminist consciousness, as measured by the Sexist Attitudes toward women Scale (SATWS), will contribute positively to self-esteem, as measured by the Coopersmith Self-esteem Inventory (CSEI), in daughters.
2. Hypothesis two: The daughter's perceptions of the mother-daughter relationship as measured by the Assessment of Interpersonal Relations (AIR), will contribute positively to her feminist consciousness, as measured by the SATWS and feminist consciousness, as measured by SATWS, will contribute positively to the daughter's perception of the mother-daughter relationship, as measured by the AIR.
3. Hypothesis three: The daughter's perceptions of the mother-daughter relationship, as measured by the AIR, will contribute positively to her self-esteem, as measured by the CSEI.

Figure 3.2
Path Analysis Model Diagram

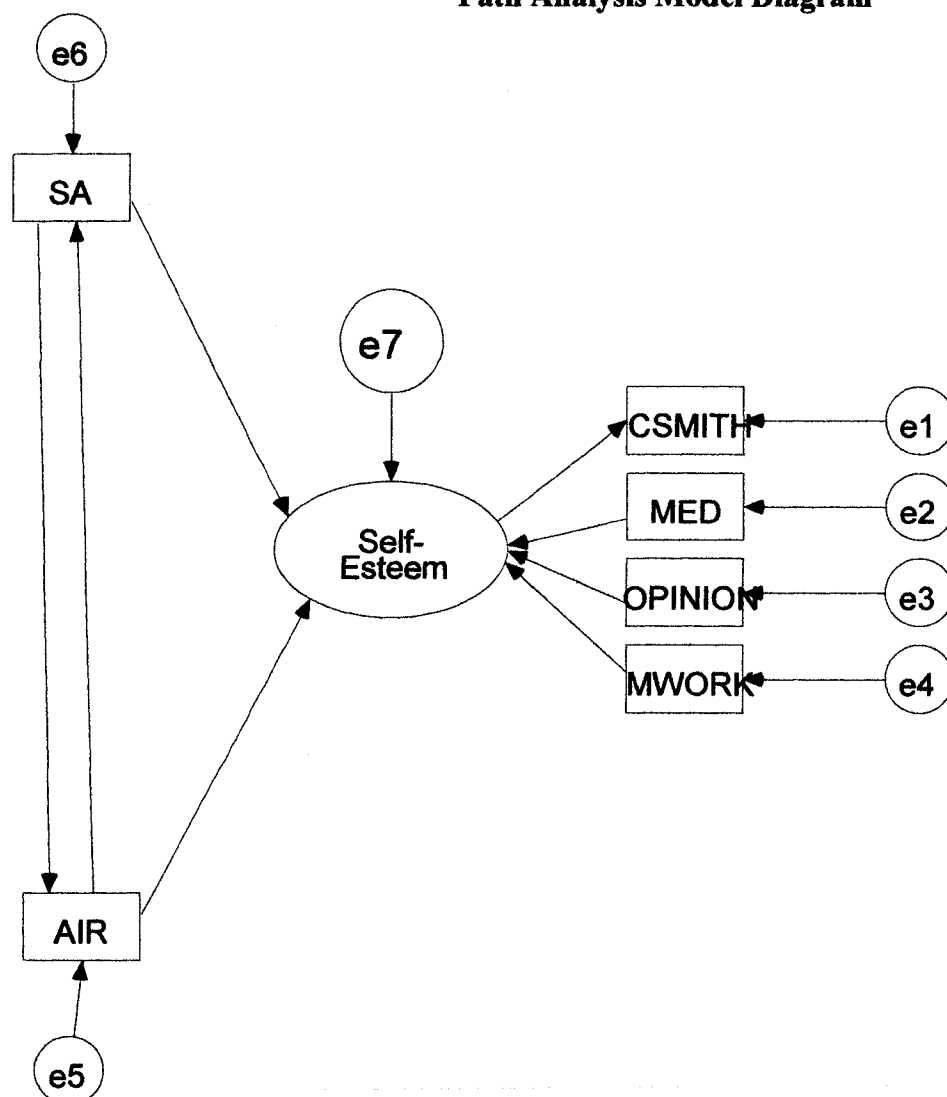

The logical extension hypothesized by the researcher was that daughters' perceptions of the mother-daughter relationship related to feminist consciousness and the daughter's self-esteem, while feminist consciousness also added to the daughter's self-esteem and her perception of the mother-daughter relationship. Another extension hypothesized by the researcher was that daughter's perceptions of the mother-daughter relationship related to feminist consciousness and the daughter's self-esteem, while feminist consciousness also added to the daughter's self-

esteem and her perception of the mother-daughter relationship. If identification and positive perception of the relationship influence the daughter's feminist consciousness and self-esteem, then does the daughter's feminist consciousness alone have a causal effect on the daughter's self-esteem and her perception of her relationship with her mother? The concern was the predictive ordering and the strength of the relationships of the variables which were diagrammed in the path analysis model. Does that model fit the data generated in this study and support the hypotheses of the study?

Data Analysis

Descriptive statistics were utilized to illustrate the participants and their mothers. Age, race, length of years living together, type of relationship, ranging from biological mother to guardian, and participants' opinion about their mothers' belief regarding the contemporary social status of women were documented. Mothers are described by age, race, education, and employment level.

Path analysis was chosen for this study to allow for a more direct and sophisticated causal link to be established and presented and permits the testing of more complex relationships. The three steps of path analysis are: to formulate a hypothesis that causally links variables of interest, to select measures of the variables that are specified by the hypothesis, and to compute the statistics to show the strength of relationship between each pair of variables that are causally linked in the hypothesis. The theory is then supported or refuted by the interpretations of the statistics (Gall, Borg & Gall, 1996), and the estimates of the strength of the hypothesized effect are based on the condition that the model is correct, that it fits the data (Klem, 1995). AMOS, a statistical program, was used to represent the path model and to calculate the path coefficients.

Ethical considerations

It appears that no harm came to the participants in this study and all ethical safeguards were in place at the time of the inquiry. Participants were informed of the voluntary nature of their involvement in the study and assured about the confidentiality of the data. They were informed of the purpose of the study and the guidelines in place to direct the inquiry. Permission was obtained from the Protection of Human Subjects Committee at The College of William and Mary and this researcher's dissertation committee. Permission was sought by appropriate school district personnel and particular school district guidelines were followed. The guidelines proposed by the Protection of Human Subjects Committee were also followed and all participants were offered the results of this study.

Limitations

Although the researcher attempted to gather data from as diverse a sample as possible, participants can still be characterized as volunteers and may not be representative of the target population. The employment of convenience sampling may limit generalizability to the target population but can be minimized by a clear and thorough description of the sample in order to infer to the population (Gall, Borg, & Gall, 1996). Participants who volunteer to complete the survey and assessment packet could have had significantly different characteristics than the non-respondent participants.

The purpose of using path analysis is to test theory about hypothesized causal links between variables. The power of the study is revealed through the appropriateness of the model and the strength of relationship between variables that are causally linked. The statistics are then used to determine and support or to refute the theory. Limitations are presented when the strength of the

relationships or the fit of the model, does not support the theory. This makes path analysis a risky statistic (Gall, Borg & Gall; Klem 1995).

The demographic survey created by this researcher does not have reliability and validity data. Also, as with all psychometric instruments, it is possible that the constructs the researcher was trying to measure were eluded by the measurement tools. Finally, the assessments and demographic survey used in this study are subject to the limitations inherent in self-report measures, such as failing to understand the directions and/or dishonesty in a participant's response set.

Delimitations

Although other familial relationships in a young woman's life are important and have influence, this study was limited to the relationship between mothers and daughters. The relationship was defined by the daughter's report of her perception of the mother-daughter relationship. No parameters were put on the relationship, if the daughter had a perception of a relationship with a mother to report whether it was a stepmother, adoptive mother, or birth mother; she was included in the study.

Although the sampling in this study attempted to include racially diverse subgroups, the instrument used to assess feminist consciousness may be limited in its ability to capture the feminist experiences and perspectives of these groups (Boisnier, 2003). Important as these differences are to the study of women and the mother-daughter relationship, it was beyond the range of this study to delineate these differences at this time.

CHAPTER FOUR

Analysis of Results

Introduction

The purpose of this study was to investigate the relationship between a daughter's perception of the mother-daughter relationship, her feminist consciousness, and her self-esteem. This chapter presents a brief overview of the sampling procedures that were utilized followed by an analysis of the data obtained.

Sampling Procedures

Four Southern Atlantic public school districts, one private school, one college, and one Northeastern public school district and community college were invited to allow their female students, ages 17-19, to participate in a research study about mothers and daughters. These institutions were chosen due to accessibility, convenience, and the potential of obtaining a diverse sample. Three public school districts declined to participate in the study.

Individuals were invited to participate in the study according to age and gender, and all participants were volunteers which made this a convenience sample. Volunteer subjects have been found to possess unique characteristics and, therefore; those who participated are likely to have different characteristics from those who did not. Consequently volunteer subjects do not represent a random sample of the target sample (Gall, Borg & Gall, 1997).

The data was collected either in person, by a liaison, or through the mail from May through November 2005. Each participant was given a survey packet containing: a consent form, a demographic survey, the Sexist Attitudes Toward Women Scale, the Coopersmith Self-Esteem Inventory, adult form, and the Assessment of Interpersonal Relations- subscale for mother only. Packets completed on site also included a pencil while packets that were mailed included a short

letter with directions on successful completion of the packet and a self-addressed return envelope.

At the Northeastern community college, a liaison in the counseling office invited students to participate in the study when they came in to register for the Summer 2005 session. These students completed the survey packets on site and returned them immediately. The institution is a two year community college that serves 5,777 undergraduate female students. The ethnic demographics for all students are as follows: 79% White, 10.7% Black, 3.6% Asian 3.6 % Hispanic and 0.3% American Indian and 2.9% undeclared. Fifty-one packets were completed six of which were returned packaged incorrectly. These packets could not be reliably used for this study. Therefore, forty-five completed survey packets from students at this Northeastern College were used in this study.

Female students registered at a Southern Atlantic college between the ages of seventeen and nineteen-- 455 in Summer 2005 and 390 in Fall 2005 -- were sent an e-mail letter explaining the study along with an invitation to participate. Recipients were asked to e-mail the researcher if they were interested in participating. These students were also offered an incentive of three \$25.00 gift certificates to be won through a random drawing of all participants. The Southern Atlantic college is a state-funded institution of post secondary education with 5,642 undergraduate students; 45% are male and 55% are female. The ethnic demographics consist of: white 66.9%, Black 5.8%, Hispanic, 4.2%, Asian or Pacific Islander, 6.6%, American Indian, 0.5% and race ethnicity unknown, 13.8%. Sixty-four survey packets were sent to potential participants, and an e-mail followed two weeks later. Fifty-six packets were returned, two of which were incomplete; therefore fifty-four completed and usable surveys were utilized in this study.

Public high school students were recruited in various ways. At the Northeastern high school, students in the family consumer science class for female seniors were asked to participate. The teacher incorporated the research concepts into a lesson, and students completed the survey packet during class. The high school is in a small rural town considered on the fringes of a mid-sized city. The high school enrolls 1,200 students with an ethnic break down of 97% White, 1% Black, 1% Asian and 1% unknown. Forty packets were given to the liaison, and twenty-two were returned completed correctly.

Students at one of the Southern Atlantic high schools were recruited by announcements and personally by the assistant principal. This high school is a part of a large school division. Total enrollment at this high school is 2010 with 44.4% males and 55.6% females. Ethnicity is 33.9% White, 55.1% Black, 3.3% Asian/Pacific Islander, 6.1% Hispanic 0.7% American Indian and 0.9% unknown. Sixty research packets were given to the liaison and twenty-three packets were returned with three having incomplete data, therefore; twenty survey packets were used in this study.

Another Southern Atlantic high school that sampled was a Catholic-affiliated private school. The school has a Lower School, PreK-7 and an Upper School consisting of grades 8 through 12. There are 290 students enrolled this year, 2205-2006. Twenty packets were given to the liaison, and twelve were returned and used in this study.

Descriptive Data Results

Of the 244 survey packets mailed or distributed to liaisons, 164 were returned. This yields a return rate of 67%. Of the 164 respondents, 153 (62% return rate of completed and usable surveys) completed all the survey instruments thoroughly and accurately and returned the packets in usable condition. Nine of the packets that were mailed were not returned, eleven

packets were incomplete or unusable due to the way they were marked or folded, and sixty packets were returned unused. The target sample size was 200, therefore the 153 completed survey packets represents a 76.5% representation of the stated sample goal.

All participants in this study were female between the ages of 17 and 19 and enrolled either in high school or in college. High school participants numbered 54 (35.3%) while 99 (64.7%) attended college. Descriptive data shows the highest number of participants 68 (44.4%) in the 18 year old age group. Forty-four respondents (28.8%) were 17 years old and 41 (26.8%) were 19 years of age.

Table 4.1.
Participants by Age

<u>Age</u>	<u>N</u>	<u>%</u>
17	44	28.8
18	68	44.4
19	41	26.8

N=153

The racial make-up of the sample is shown in Table 4.2. The sample consisted of 101 (66%) Whites, 29 (19%) Blacks, 1 (.7%) American Indian/Alaska Native, 3(2%) Asians, 2 (1.3%) Hawaiian /Pacific Islander, 6 (3.9%) Hispanics, 1 (7%) other race, and 9 (5.9%) bi- or multi-racial.

Table 4.2
Participants by Race

<u>Race</u>	<u>N</u>	<u>%</u>
White	101	66
Black	29	19
American Indian/Alaska Native	1	.7
Asian	3	2.0
Native Hawaiian/Pacific islander	2	1.3
Hispanic	6	3.9
Other Race	1	.7
<u>Bi or Multi racial</u>	<u>9</u>	<u>5.9</u>
N=153		

Most respondents, 136 (88.9%), reported living with their biological mothers, 10 (6.5%) with adoptive mothers, 6 (3.9) with stepmothers, and 1 (7%) with her foster mother. The majority, 140(91.5%), also reported living with their mother for fifteen plus years while 4 (2.6%) reported ten to fifteen years, 6 (3.9%) five to ten years and 2 (1.3%) for five years. Also, participants were asked their opinions about how their mothers would rate this statement: “My mother believes that women and men should be treated equally politically, economically, and socially.” Fifty-six (36.6%) marked strongly agree, fifty-five (35.9%) agree, seventeen (11.1%) were not sure while sixteen (10.5%) marked disagree and 9 (5.9%) strongly disagree.

Table 4.3
Participants' opinion of their Mother's belief about male/female equality

<u>Participants' Opinion</u>	<u>N</u>	<u>%</u>
Strongly Disagree	9	5.9
Disagree	16	10.5
Not Sure	17	11.1
Agree	55	35.9
<u>Strongly Agree</u>	<u>56</u>	<u>36.6</u>

N=153

Mothers were described by their daughters in this study by age, race, education, and type of work. The highest number of mothers, fifty-two (34%), were classified as 48-55 years of age and fifty-one (33.3%) fell in the 43-48 age range. Twenty-eight (18.3%) were 38-42 years of age and fifteen were 32-37, while 6 (3.9%) were 55 and older. Race reflected approximately the same numbers as self-reported by the daughters. Whites made up 110 (71.9%), Blacks, 27 (17.6%), Hispanic, 5, (3.3%), Asian, 4, (2.6%), Native Hawaiian/Pacific Islander 1, (.7%) and other race and bi- and multi-racial both were reported as 3 or (2.0%).

Most mothers, eighty-two (53.6%), worked full time, 26, (17%), worked part-time, 14 (9.2%) were self-employed, while 24 (15.7%) were stay-at-home mothers, and 7 (4.6%) were unemployed. Education levels for participant's mothers ranged from elementary school to having completed post-graduate degrees. The high school graduate level consisted of fifty-one or (33.3%) of the mothers, 3 mothers attended technical school, (2.0%), 13 (8.5 %) were community college graduates, 14 (9.2%) reported having some college education, while 39, (25.5%) completed college degrees. Ten of the mothers, (6.5%) attended some graduate school

classes while 17, (11.1%) attained graduate degrees (masters). Five (3.3%), had achieved a doctorate degree.

Table 4.4
Mother's Education Level

<u>Mother's Education Level</u>	<u>N</u>	<u>%</u>
Elementary School	1	.7
High School	51	33.3
Technical School	3	2.0
Community College	13	8.5
Some College	14	9.2
College Degree	39	25.5
Some Graduate School	10	6.5
Graduate Degree (Master's level)	17	11.1
<u>Doctoral Degree</u>	<u>5</u>	<u>3.3</u>

N=153

Descriptive data and measures of central tendency are indicated for the three outcome measures used in this study. Scores on the Assessment of Interpersonal Relations (AIR) - mother subscale, measuring the mother-daughter relationship, had a possible raw score range of 35-140. For all participants of this study, females 17-19, the mean raw score on the AIR was 102.59 (SD = 18.81) compared to the mean raw score of 111.19 (SD = 21.22) for females ages 17-19 in the standardization sample. The AIR was standardized on a sample of 2,501 children ranging in age from 9-19 years of age.

Demographics for the Sexist Attitudes Toward Women Scale (SATWS) were obtained in 1976 and 1977 and included both high school and college students. Possible scores ranged from 40 to 280 with higher scores indicating greater sexism. The average mean score for female college students, sample of 60, was 85.23 (SD=18.81) and for female high school students, with a sample of 56, the mean score was 122.95 (SD=28.14). The college students in the original sample had substantially lower scores than high school females. The rationale for this finding could be either generational or developmental in nature (Benson & Vincent, 1980).

Results for the present study reveal mean scores on the Sexist Attitudes Toward Women Scale (SATWS), used to measure feminist consciousness, for this sample was 80.68 (SD=15.56). For college women, a mean of 78.58 (SD=15.35) was found for a sample of ninety-nine and for high school women, a sample of fifty-four, 84.5 (SD=15.32) was the mean score. A comparison of college women and high school women in Table 4.6 show lower scores for college women but the range is not as broad as was found in the original sample used by Benson and Vincent (1980).

The mean score on the Coopersmith Self-Esteem Inventory (CSEI), a measure of self-esteem, for the sample was 64.54 (SD =22.53). Norms for the adult form are reported by sex, ethnicity, and age. The mean score for females was 71.6 (SD =19.5) with a sample of 112, and the mean for females aged 16-19 was 66.7 (SD =19.2) for a sample of 78.

Table 4.5
AIR, SATWS, CSEI
Means and Standard Deviations

<u>Outcome Measure</u>	<u>Mean</u>	<u>Standard Deviation</u>
AIR	102.59	18.81
SATWS	80.68	15.56
CSEI	64.54	22.53
N=153		

Table 4.6
AIR, SATWS, CSEI
Means and Standard Deviations
By Participants Education Level

Education Level		CSEI	AIR	SATWS
College				
	Mean	65.19	101.17	78.58
	SD	23.29	18.66	15.35
	N=99			
High School				
	Mean	63.33	105.19	84.52
	SD	21.24	18.99	15.32
	N=54			

Data Analysis for Research Hypotheses

In this section the three research hypotheses for the study are reiterated, path analyses fit measures are defined, and the path analysis is diagrammed followed by the findings. The analyses for the study were carried out with the Statistical Package for the Social Sciences program (SPSS 13.0; SPSS, 2004) and the Analysis of Moment Structures (AMOS 4.0; Arbuckle, 1999- 2003) program. Indices of “fit,” as used in path analysis refers to the amount of consistency between the theoretical model being tested and the data, and involves comparing all the implied correlations to all the actual correlations. The path diagram model with corresponding path coefficients indicates the magnitude of the direct effect of one variable on another (Klem, 1995). Measures of fit used for path analysis are defined in Table 4.7.

Table 4.7
Path Analyses Fit Measures (Lambie, 2002)

Fit Index	Acronym/Definition	Interpretation
Chi-square	x² Extent to which the overall model (structural and measurement) predict the observed covariance	In general, if the ratio between x ² and <i>df</i> is less than two, the model is a good fit (Ullman, 1996).
Degrees of Freedom	df	The number of scores free to vary when calculating statistics
Probability Level	p	If probability of the x ² is non-significant the model fits well
Goodness of Fit Index	GFI Extent to which the overall model (structural and measurement) predict the observed covariance	Ranges from zero (0) to one (1), where one (1) indicates a perfect fit, and scores below 0.8 identify a poor fit.
Adjusted Goodness of Fit Index	AGFI Accounts for the <i>df</i> necessary to achieve the fit	Ranges from zero (0) to one (1), where 0.90 or greater indicates a good fit
Comparative Fit Index	CFI Compares the fit of an independent model (a model which asserts no relationships between variables) to the fit of the estimated model.	Usually range from zero (0) to one (1), where 0.90 and greater are accepted values that indicate good fit.
Root Mean Square Error Approximation	RMSEA (x²/<i>df</i>) Compares the fit of an independent model (a model which asserts no relationships between variables) to the fit of the estimated model.	When score is .05 or lower a good fit is being indicated.
Tucker-Lewis Index	TLI Extent to which the specified model performs better than a baseline model	Usually range from zero (0) to one (1), where one (1) indicates a very good

Figure 4.1
All Hypotheses: Path diagram

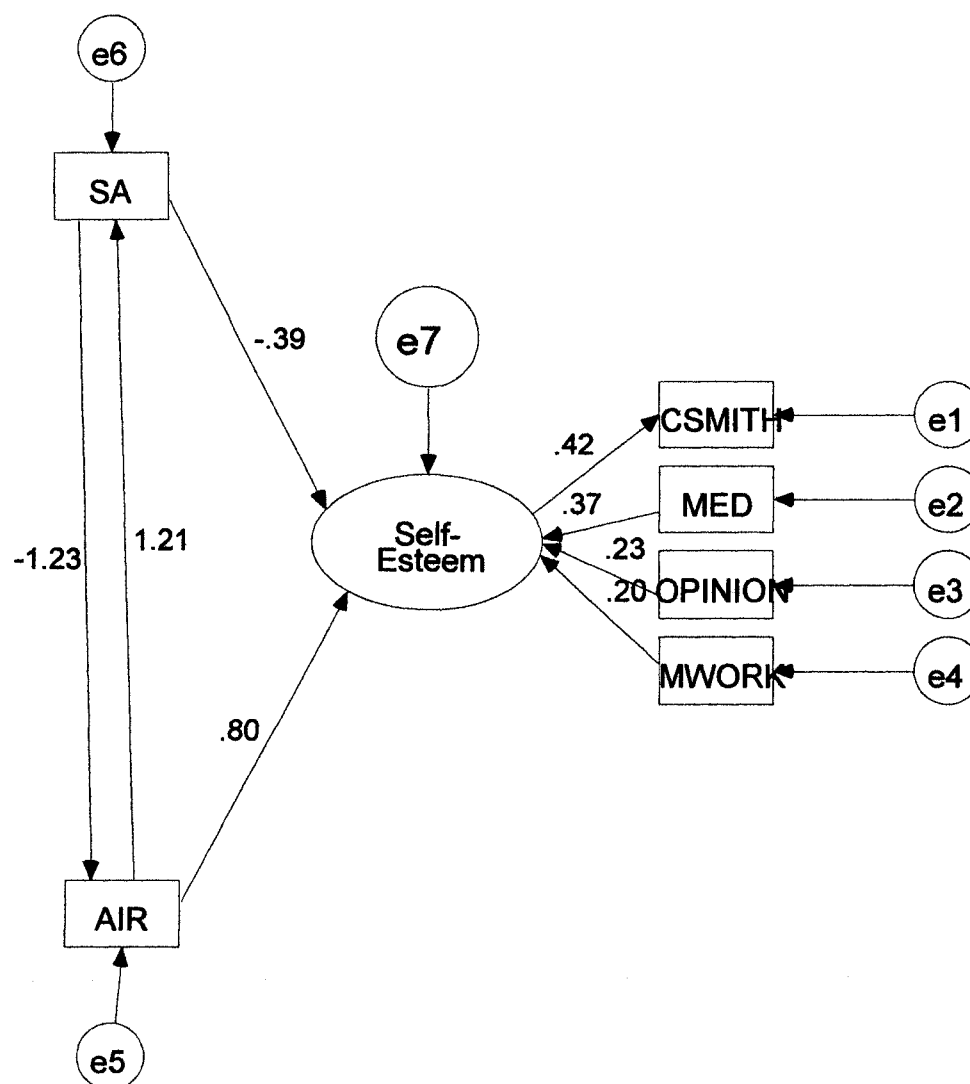

Table 4.8
All Hypotheses: Path Analysis Fit Indices

χ^2	<i>df</i>	<i>p</i>	GFI	AGFI	CFI	RMSEA	TLI
43.623	9	.000	0.902	.772	.471	.159	.118

Note. N=153

All hypotheses for this study were depicted in one path analysis diagram (figure 4.1). Path analysis fit indices (table 4.8) show a significant Chi square indicating that the model did not fit the data. Therefore the theory expressed by the model was not supported.

Hypothesis 1:

Feminist consciousness, as measured by the Sexist Attitudes toward women Scale (SATWS), will contribute positively to self-esteem, as measured by the Coopersmith Self-esteem Inventory (CSEI), in daughters.

Figure 4.1 presents the path analysis modeling for the data for hypothesis one. The path fit indices reveals a significant Chi square indicating that the model does not fit the data. Therefore, the hypothesis is not supported by the data, thus; feminist consciousness does not contribute to self-esteem in this model.

Hypothesis 2:

The daughter's perceptions of the mother-daughter relationship as measured by the Assessment of Interpersonal Relations (AIR), will contribute positively to her feminist consciousness, as measured by the SATWS and feminist consciousness, as measured by SATWS, will contribute positively to the daughter's perception of the mother-daughter relationship, as measured by the AIR.

Figure 4.1 depicts the path analysis model for the data for hypothesis two. The path fit indices reveals a significant Chi square indicating that the model does not fit the data. Consequently, there was neither a direct or mutual contribution between daughters' feminist consciousness and her perceptions of the mother-daughter relationship in this model.

Hypothesis 3:

The daughter's perceptions of the mother-daughter relationship, as measured by the AIR, will contribute positively to her self-esteem, as measured by the CSEI.

Figure 4.1 depicts the path analysis model for the data for hypothesis three. The path fit indices reveals a significant Chi square indicating that the model does not fit the data. As a result, the daughter's perception of the mother-daughter relationship does not contribute to the daughter's self-esteem in this model.

Other endogenous variables used in the path analysis were the mother's education, mothers' work, and the daughter's opinion of her mother's beliefs about this statement: "My mother believes that women and men should be treated equally politically, economically, and socially." These variables were employed to help recognize other potential sources that may contribute to daughter's levels of self-esteem. Regression weights for all variables in the path are shown in Table 4.9. Mother's level of education was significant to the daughter's self-esteem with a regression weight of .367. Mothers' work and the daughters' belief regarding their mothers' opinion about the equality of men and women were not significant.

Regression weights for contributions to self-esteem (CSEI) by all variables in the path analysis; daughter's perception of the mother-daughter relationship (AIR), feminist consciousness (SATWS), and mother's education level were shown as significant in the path model. The mother-daughter relationship .797, feminist consciousness -.390 and mother's education level .201, show significant path coefficients to daughter's self-esteem. Due to the scoring of the Sexist Attitudes Toward Women Scale, with lower scores showing less sexism, the regression weight is reported as a negative. Also, the path coefficient between feminist consciousness and the mother-daughter relationship was -1.230 and presented as

significant while the coefficient from the mother-daughter relationship toward feminist consciousness, 1.209 was not significant. It is important to understand that the estimates acquired in the analysis are conditional on the model being correct (Klem, 1995).

Table 4.9
Regression Weights
Revealed through Path Analysis

Variable	Estimate	P
Self-esteem <---Mother's education level	.367	.038
Self-esteem <---Opinion	.228	.198
Self-esteem <---Mother's work	.201	.256
Self-esteem <---SATWS	-.390	.028
Self-esteem <---AIR	.797	***
AIR<---SATWS	-1.230	***
SATWS<---AIR	1.209	

The purpose of using path analysis is to test theories about hypothesized causal links between variables. The power of the study may have been revealed through the appropriateness of the model and the strength of relationship between variables that are causally linked. It is important to realize that the estimates obtained in the analysis are conditional on the model being correct. The statistics are then used to determine whether to support or refute the theory. Limitations are presented when the strength of the relationships does not support the theory which makes path analysis a risky statistic (Gall, Borg & Gall; 1996; Klem, 1995).

Further Analyses

To further recognize and realize the possible implications of the significant data portrayed in the path analysis results, a linear multiple regression was applied to all the variables in the path model. This included the dependent variable of self-esteem with the independent variables, mother-daughter relationship, feminist consciousness, mother's education level,

mother's work, and the opinion statement. Also, a Pearson product moment correlation was applied to further understand the connection between these variables.

The results of the multiple regression analysis are found in Table 4.10. Self-esteem is shown with the specified independent variables to have a statistically significant relationship. As shown, the Beta weights feminist consciousness was significant at the .05 level while the mother daughter relationship was significant at the .01 level, suggesting a positive relationship between these variables and daughters' self-esteem. The R squared value for the equation was .214 indicating that these variables accounted for a statistically significant amount of the self-esteem variance and a moderate effect size (21%, $F [5, 152] = 7.983, p < .000$).

Table 4.10
Multiple Regression Results for Self-esteem, Mother-Daughter Relationship, Mother's Education Level, Opinion, Mother's Work, and Feminist Consciousness

Multiple R	.462				
R Square	.214				
Adjusted R Square	.187				
Standard Error	20.324				
<hr/>					
Analysis of Variance					
	Sum of Squares	df	Mean Square	F	Sig.
Regression	16488.067	5	3297.613	7.983	.000
Residual	60719.985	147	413.061		
Total	77208.052	152			
<hr/>					
Variables	B	SE B	Beta	T	Sig.
AIR	.388	.092	.324	4.209	.000
OPINION	1.751	1.503	.093	1.165	.246
MED	1.465	.781	.149	1.876	.063
MWORK	1.423	1.284	.082	1.108	.270
SATWS	-.230	.111	-.158	-2.069	.040
(Constant)	26.726	13.814			.055
<hr/>					

Pearson product moment correlations (two-tailed) were applied to demonstrate associations between self-esteem, the mother-daughter relationship, mother's level of education, and feminist consciousness, opinion, and mothers' work.. The results indicate a statistically significant positive correlation between self-esteem and the mother-daughter relationship ($r = .365, p = .001$), and between self-esteem and mother's education ($r = .273, p = .001$), and self-esteem and feminist consciousness ($r = -.190, p = .019$) and self-esteem and opinion ($r = .243, p < .001$). Additionally, mother's education and the mother-daughter relationship ($r = .208, p < .010$), and mother's education and feminist consciousness ($r = -.231, p < .004$) and mother's education and the opinion statement ($r = .309, p < .00$), had significantly positive relationships. The opinion statement had significantly positive relationships, ($r = .246, p < .002$) with the mother-daughter relationship and with feminist consciousness ($r = -.194, p < .019$). Mother's work did not significantly correlate to any other variable. Due to the scoring of the Sexist Attitudes Toward Women Scale, with lower scores showing less sexism, the correlations for feminist consciousness are reported as negative.

Table 4.11
Correlations among Self-esteem, Mother-daughter relationship, Mother's Level of Education Feminist Consciousness, Opinion, and Mother's Work

	1	2	3	4	5	6
1. CSEI	--	.365**	.273**	-.190*	.243**	.024
2. AIR		--	.208**	.043	.246**	-.075
3. MED			--	-.231**	.309**	-.097
4. SATWS				--	-.194*	.082
5. OPINION					--	-.068
6. MWORK						--

** Correlation is significant at the 0.01 level (two-tailed)

* Correlation is significant at the 0.05 level (two-tailed)

This chapter illustrates the results of the data analysis procedures including descriptive analyses, path analyses modeling, a report of the models regression weights, and extended analysis using multiple regression, and correlational analyses. The following chapter examines and discusses the presented results and their possible implications and limitations.

CHAPTER FIVE

Discussion of the Results

This chapter begins with a rationale for the study, a review of the results, and a discussion regarding each of the research hypotheses. Findings are discussed in light of the relevant literature and possible reasons for the outcomes. Additional findings, limitations, and recommendations for future research are offered with implications of the present findings discussed.

Rationale for the study

Girls and women need support and encouragement to understand clearly the effects of sexism in a patriarchal social society. Through quality relationships with significant female adults, their mothers, and encouragement for understanding sexism, adolescent girls may understand and externalize the devaluation of women and internalize a higher self-esteem and willingness to be authentic in the world (Blascovich & Tomaka, 1991; Moradi & Subich, 2002). The perpetuation and devastation of the myths of sexism and oppression are difficult to tease out in women's experiences of being socialized within the patriarchy. The mother-daughter relationship which has been undervalued and maligned as conflictive or enmeshed may actually be the fertile foundation for increasing the daughter's self esteem through the mother's valuing of the daughter and the connection (Buysse, 1999; Josselson, 1987; Walters, Carter, Papp & Silverstien, 1988). Due to the powerful effect of socially constructed gender roles on the thinking of human beings, it is important to present favorable circumstances to increase consciousness and sensitize individuals to these issues (Goodrich, 1991). The opportunity for daughters to investigate the concepts of feminism and their own feminist consciousness is rarely offered in any setting.

Feelings of not quite measuring up are a dilemma that chip away at women's identities and feelings of worth. A psychological structural balance must be found between women's self-identified flaws and positive attributes. Preoccupation with flaws and never measuring up grossly distort the self-esteem and the negatives outweigh the positives for women. When a major event forces a woman to change, self-concept dislocation can hinder her from integrating these new experiences and accepting the new self as okay (Sanford & Donovan, 1984). A woman's disempowered status in the patriarchy, that of less than, makes her vulnerable to ambiguous and confounding messages. These messages supported by a male dominated society devalue feminine qualities and perpetuate the systematic oppression of women (de Beauvoir, 1952). Without higher levels of understanding and the clarity to navigate and externalize these messages, women remain in the quagmire of lower status and a hopeless state of second class citizenry.

The mother-daughter relationship appears to be highly influential on daughters' self-esteem and feminist consciousness and studying this relationship may allow for a greater understanding of how women make sense of themselves in contemporary society. Raising consciousness of women's issues, and understanding and eradicating the oppression of women in the larger social context may start within relationships that women have with each other, specifically the mother-daughter relationship (Debold, Wilson & Malave, 1993; Flax, 1978).

This study was based on the assumptions of theory. Tenets of contemporary psychoanalytic theory, social learning theory, and feminist theory purport that the mother-daughter relationship is a unique bond and that through identification, socialization, and connection, mothers have tremendous influence on their daughters (Boyd, 1889; Buysse, 1999; Chodorow, 1978; Goldberg, 1995; Josselson, 1987; Walters, Carter, Papp & Silverstien, 1988). Women with

higher feminist consciousness hold out hope for themselves (Stein & Weston, 1982), possibly through valuing women and women's ways. Through identification with the mother and socialization by the mother, the daughter's perception of the relationship may in turn allow the daughter the freedom and validation to hold women in high esteem and therefore the self in high esteem. The intention of investigating these principles is to promote an understanding of female development, feminist consciousness, and self-esteem; to better understand the dynamics of the mother-daughter relationship and to encourage women to think more openly about their status in society as it affects the daughter.

Review of the Results

The research question investigated in this study was: what relationship exists between daughters' perceptions of the mother-daughter relationship, feminist consciousness, and self-esteem? Three hypotheses were put forward in order to explore a particular theoretical model. They are as follow:

Hypothesis 1:

Feminist consciousness, as measured by the Sexist Attitudes Toward Women Scale (SATWS), will contribute positively to self-esteem, as measured by the Coopersmith Self-esteem Inventory (CSEI), in daughters.

The path analysis model used to analyze this hypothesis revealed that the model did not fit the data. The results of the analysis indicated that the theoretical model tested did not fit the data well, and that daughters' feminist consciousness does not have a direct contribution to daughters' self-esteem. The results of the path analysis contradict some of the findings reported in the literature. Smith (1999) reported that although feminists and anti-feminist women both saw gender as important to self-esteem, feminists had higher means on measures of their own judgment about the goodness of their gender group. Additionally, results of a study by Stein and

Weston (1982) strongly support the hypothesis that college-aged women who were more pro-feminist in their attitudes toward women, scored higher on measures of identity achievement which may subsume self-esteem.

Hypothesis 2:

The daughter's perceptions of the mother-daughter relationship, as measured by the Assessment of Interpersonal Relations (AIR), will contribute positively to her feminist consciousness, as measured by the SATWS and feminist consciousness, as measured by SATWS, will contribute positively to the daughter's perception of the mother-daughter relationship, as measured by the AIR.

The model theorized in the path analysis to analyze this hypothesis, revealed that the model did not fit the data. Based on these findings, neither a direct or mutual contribution exists between the daughters' perception of the mother-daughter relationship and the daughter's feminist consciousness.

This result opposes the literature that supports the relationship of the variables. Although none of studies used the same measures to assess the constructs, and the literature was used in an inferential way, the hypothesis appeared reasonable given the magnitude of the research and the results. Buysse (1999) reported that mutuality in the relationship influenced the daughter's feminist consciousness, and Meier (1972) reported that mother's salience or the "mother role" shaped sex role attitudes in children. Using identification as a theoretical underpinning, if sex-role attitudes of the mother highly affected sex role attitudes of the daughter (Smith & Self, 1980; Weeks, Wise, & Duncan, 1984) and the salience of the relationship influenced sex-role attitudes (Sholomskas & Axelrod, 1986), an extension of theory would be that the relationship

would also influence feminist consciousness, which is related to sex-role attitudes of the daughter.

Notar and McDaniel (1986) also reported in their study that the majority of daughters who have good relationships with their mothers see both themselves and their mothers as feminists. Problems in the relationship occurred when the mother was not a feminist.

Hypothesis 3:

The daughter's perceptions of the mother-daughter relationship, as measured by the AIR will contribute positively to her self-esteem, as measured by the CSEI.

The model created to analyze the data for this hypothesis through path analysis does not fit the data. This outcome is contrary to the literature. The literature used to create this aspect of the analysis is strong.

Findings in the research (Peterson & Roberts, 2003) highly support the concept of same sex concordance between mothers and daughters. Also, according to a study by Sholomskas and Axelrod (1986) the mother-daughter relationship highly influenced daughters' role satisfaction and was the main factor that contributed to daughters' self-esteem. Baruch and Barnett (1983) also reported modest but significant correlations between maternal rapport and daughters' psychological well-being.

Discussion of the Results

One path analysis model was created to analyze the data for all three hypotheses formulated for this study. The path model that was fashioned for this study did not fit the data. Estimates observed in the analysis are conditional on the model being correct. In other words data from a path analysis that is not correct is considered unconfirmed (Klem, 1995). Therefore this theory is unsupported by the findings in this study.

It is important when discussing the statistically non-significant findings (lack of fit) to recognize that possibly no relationship between the constructs exists, although significant path coefficients were evident. Another possibility was that the placement of variables in the model was incorrect and therefore no relationship was evident but actually exists within another representation of the variables. It is also acceptable to take into account the body of literature examined and to investigate the possible circumstances that led to a lack of support for the research hypotheses.

The conceptualizations informing the development of the model extended previous theoretical implications in a new direction specific to the relationship between the mother-daughter relationship and daughters' feminist consciousness. However, in light of the lack of fit, a reexamination of the literature was warranted. While there appeared to be substantial evidence that there was a connection between the mother-daughter relationship and feminist consciousness, when reviewing the literature further, multiple lines of relationship were apparent. In the literature, not only does the mother-daughter relationship affect the daughter's feminist consciousness, but it was also evident that the mother's feminist consciousness affects daughter's feminist consciousness as well (Buysse, 1999; Smith & Self, 1980; Weeks, Wise & Duncan, 1984). From these studies inferences were made for the present study concerning the mother-daughter relationship, yet it is possible that mothers' feminist consciousness, which was not directly measured in this study, is the prominent connection in relation to daughter's feminist consciousness.

Daughters were asked on the demographic survey, in your opinion, how would you rate this statement, "My mother believes that women and men should be treated equally politically, economically and socially." This question served to provide information on how daughters

perceived their mother's beliefs about the equality between men and women. Mothers of the daughters in the sample, according to daughters' opinions leaned more towards feminist attitudes than not with 72.5% of participants responding that they agreed or strongly agreed about their mother's beliefs regarding the statement. Based on reviewing the literature, it is possible that these opinions of mothers' beliefs which may have assessed mothers' feminist attitudes in some small way, would better serve to demonstrate a connection to the daughter's feminist consciousness, rather than self-esteem.

The outcome of this study created a myriad of questions. Therefore, in order to investigate further, additional analyses were applied to the data to better understand the significant relationships some variables in the path analysis appeared to comprise. The mother-daughter relationship, feminist consciousness, and mothers' education level appeared to have significant links to self-esteem. Multiple regression and correlational analysis were performed and the results were applied to the hypotheses of this study for discussion purposes.

Limitations

There were several limitations observed in this study. Although structural equation modeling tests hypothesized causal paths, true causality cannot be determined. Correlations between two variables are linear and only show relationship, they do not allow us to speculate about cause. Also, path analysis can be a risky statistic, as one set of variables in the model can produce a result of the model not being a good fit for the entire data set.

Secondly, there were numerous issues with the sample in this study. A reasonable sample size for using path analysis is generally 100-300 participants. The smaller number of 153 could have affected the analysis (Klem, 1995). Also, the lack of diversity of the sample hinders the

ability to generalize and to understand ethnic differences. The use of a convenience sample that was comprised of volunteers also hinders the generalizability of the results.

The instruments utilized in this study were self-report surveys and subject to the limitations of all such surveys. The Coopersmith Self-esteem Inventories and Sexist Attitudes Toward Women Scale (SATWS) are older instruments and although have good reliability and validity may be suspect to the impact of history. The SATWS had blatant issues with dated language and although permission was granted to change two questions, there was no way to measure or understand the impact of those changes. Also, the unique intricacies and nuances of the mother-daughter relationship may not have been assessed by the Assessment of Interpersonal Relations which looks at numerous interpersonal relationships using the same set of questions.

Finally, there are inherent advantages and disadvantages when defining and measuring the psychological construct of self-esteem. As this was the target construct for this study discussion about its limitations is warranted. The current study illustrated that self-esteem is interrelated with the mother-daughter relationship, feminist consciousness, mothers' education and the opinion question, which represented mothers' feminist consciousness in a small way. There is evidence in the literature that there are other influences on the self-esteem of adolescent/young adult women. Research indicates that body image, relationships with friends and romantic attractions, attitudes about one's gender, competence, perceptions of the educational environment, achievement and values may contribute to self-esteem (Baruch, 1976; Fischer & Good, 1994; Polce-Lynch, Myers, Kliever & Kilmartin, 2001; Smith, 1999; Thomas & Daubman, 2001)

Therefore, due to the multidimensionality of the construct, it is important to be as thoughtful and comprehensive as possible when attempting to measure self-esteem. The original path model in this study utilized an ellipse to depict the theoretical construct self-esteem and this was

measured using one single assessment, the Coopersmith Self-esteem Inventory. When considering other variables that could be a component of or a proxy for self-esteem it is imperative to work toward capturing the construct more completely. This can be done in a variety of ways. One suggestion would be to use an instrument that captures separate domains of self-esteem such as the Multidimensional Self Concept Scale (Bracken, 1992). This instrument assesses social, competence, affect, academic, family and physical aspects of self-concept. Research designs evident in the literature use multiple measures to create a composite variable. For example, psychological well-being can be measured using a general symptoms index, self-esteem and a mastery scale and self-esteem may be composed of measures assessing body image, identity, competence and sense of self in the world (Baruch, 1976; Charles, Frank, Jacobson & Grossman, 2001; Lytle, Bakken & Romig, 1997; Smith, 1999; Stein & Weston, 1982). There are a variety of methods to be investigated to truly garner the essence of what the construct self-esteem entails and thought and care should be foremost when measuring this construct. Therefore the use of one measure to assess self-esteem in this study was a limiting factor.

Discussion of Additional Findings

The multiple regression analyses revealed Beta weights for feminist consciousness that were significant at the .05 level while the mother daughter relationship was significant at the .01 level, suggesting a positive relationship between these variables and daughters' self-esteem. The R squared value for the equation was .214 indicating that these variables accounted for a statistically significant amount of the self-esteem variance and a moderate effect size (21%, $F [5, 152] = 7.983, p < .000$). These values expressed that approximately 21% of the variance accounted for in self-esteem can be explained by the mother-daughter relationship, feminist

consciousness and mother's education level. Due to the significance of the multiple regression equation a correlational analysis was performed.

Pearson product moment correlations (two-tailed) were applied to demonstrate associations between self-esteem and all the independent variables in the path analysis: the mother-daughter relationship, mother's level of education, feminist consciousness, mothers' opinion and work. The results indicated a statistically significant positive correlation between self-esteem and the mother-daughter relationship ($r = .365, p = .001$), and self-esteem and mother's education ($r = .273, p = .001$), and self-esteem and feminist consciousness ($r = -.190, p = .019$) and self-esteem and opinion ($r = .243, p < .001$). Additionally, mother's education and the mother-daughter relationship ($r = .208, p < .010$), and mother's education and feminist consciousness ($r = -.231, p < .004$) and mother's education and the opinion statement ($r = .309, p < .001$), had significantly positive relationships. The opinion statement had significantly positive relationships, ($r = .246, p < .002$) with the mother-daughter relationship and with feminist consciousness ($r = -.194, p < .019$). Mother's work did not significantly correlate to any other variable. Due to the scoring of the Sexist Attitudes Toward Women Scale, with lower scores showing less sexism, the correlations for feminist consciousness are reported as negative.

The strongest positive significant correlation in the analysis was between the mother-daughter relationship and self-esteem. Given the depth of the research literature on this connection, this finding is not surprising. Mother's education and opinion, about the equality of men and women, were the next strongest positive significant correlation. Daughter's perception of her mother's opinion related to her self-esteem and the mother-daughter relationship was the next coefficient in magnitude. Mother's education and the feminist consciousness of her daughter were the next in strength and according the Meier (1972) and Smith and Self (1980)

mother's education, particularly when college educated had an effect on daughter's sex role attitudes. Mother's education also had an effect on the mother-daughter relationship and the weakest correlation coefficient in the analysis was the relationship between daughters' feminist consciousness and her mothers' opinion about the equality of men and women and daughter's feminist consciousness and her self-esteem.

Path analysis is a precarious statistic (Klem, 1995). If the model is incorrect due to any incorrect hypothesis, the entire model is not a correct fit and if the model does fit, the results allow the expansion of theory. Looking at the correlational data, the most revealing gap is the non-significant relationship between the mother-daughter relationship and feminist consciousness. Also, mothers' work does not correlate with any of the other variables in the study. Given that all other variables in this model are positively significantly correlated and the multiple regression equation significant, in combination with the magnitude of support from the research literature, it is logical to consider theorizing a new path model to fit the data for use in future research.

Recommendations for Future Research

Based on these correlation coefficients it was reasonable to consider that the path model and theoretical foundation, and not the proposed connection of the variables is incorrect. Logically, new models were hypothesized and investigated using a clearer understanding of the literature. Due to the fact that mothers' feminist consciousness (Buysse, 1999) and mothers' level of feminism (Sholomskas & Axelrod, 1986) appear to have a stronger link to daughters' feminist consciousness than self-esteem, the data collected from the opinion question which revealed an inkling of mothers' feminist consciousness was correlated with daughter's feminist consciousness and not directly to self-esteem. Also, mothers' work does not correlate with any of

the other variables in the study and was thus removed from the model, while mothers' education level correlated with all other variables and was considered more inclusively in the model. Given that all other variables in this model are correlated and the multiple regression equation significant, in combination with the magnitude of support from the research literature, it is logical to reconsider theorizing a new path model to fit the data. Reorganizing the variables with new placement to represent a clearer understanding of the relationships between variables allows for the creation of a model, based on theory and information, which fits the data. A new path model was formulated and is shown as a path diagram in figure 5.1 with path analysis fit indices in table 5.1. This provides a model that fits the data and a reasonable way to look at the interrelationships of the variables for future research purposes.

Figure 5.1
Alternate Path Analysis Model

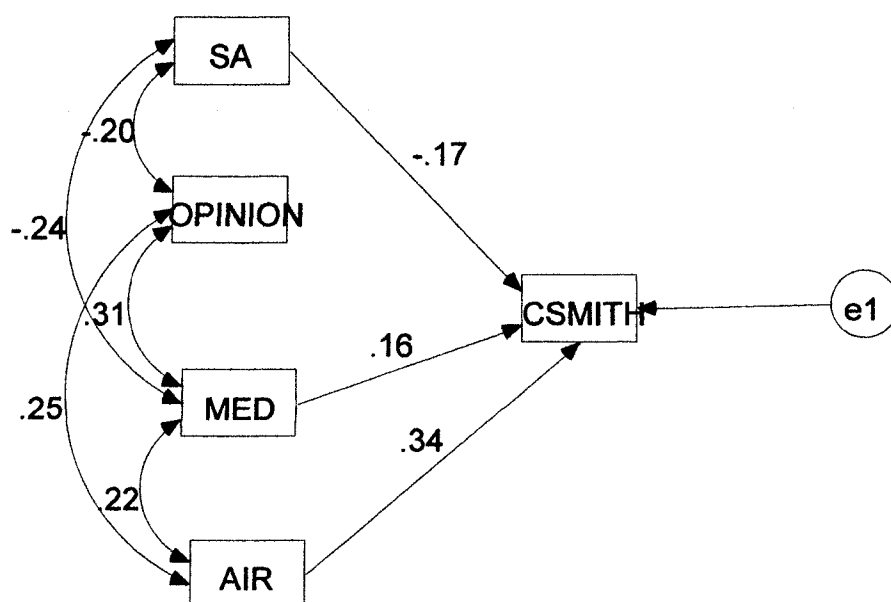

Table 5.1
Alternate path: Path Analysis Fit Indices

X^2	d	p	GFI	AGFI	CFI	RMSEA	TLI
1.612	2	.447	.996	.968	1.0	.000	1.029

Note. N=153

Fit measures for the alternate path diagram are noted in table 5.1. The path fit indices revealed a non- significant Chi square indicating that the model does fit the data. All other indices specified that the model fits the data with the goodness of fit indices (GFI) reaching .996.

Other recommendations for future research include investigating the relationship between mothers' feminist consciousness and daughters' self-esteem and feminist consciousness. Such a study would include both mothers and daughters as participants. Additionally, there is support that due to the intensity, longevity, and influence of the mother-daughter relationship, there is a connection between mothers' self-esteem and daughters' self-esteem, which may be a variable that needs to be considered when studying this relationship (Charles, Frank, Jacobson & Grossman, 2001).

Clearly this study was based on a sample that was more representative of white students and those who attend college. The mother-daughter relationships investigated were also characterized by educated mothers. The mothers in the sample were at least high school educated with a large percentage having graduated from college and or having some college education. As this is not representative of the target population it would be of value to study participants of varying education levels to ascertain and understand what other variables influence self-esteem. Since mothers' education level is interrelated with daughters' self-esteem, the mother-daughter relationship, feminist consciousness and the opinion question it may be worthwhile to scrutinize

further the factors and influences that can be used for intervention, to increase the self-esteem of more diverse populations of young women.

When investigating the influences on the self-esteem of adolescents there was very little literature on the effects of fathers on their children. One study by Peterson and Roberts (2003) on the concordance of same-sex dyads of parents and children, found no relationship with fathers and younger or older children, boys or girls on the construct of concordance. Investigating the similarities and differences between daughters' relationships with fathers and mothers could possibly yield information that would be helpful to families and the changing roles of men in contemporary society.

Implications and Summary of the Study

Clearly, there is much that is unknown about the influence and development of self-esteem in young women. Numerous studies point to the fact that gender is a salient issue in the construct of self-esteem and females have lower levels of self-esteem than do males (McMullin & Cairney, 2004; Thomas & Daubman, 2001). The mother-daughter relationship is only one facet in examining self-esteem with regard to young women, but it appears to be quite significant. Other variables, feminist consciousness, mother's education level, and friendships play an influential role as well. Yet in a fast paced society with ever changing sociopolitical factors, staying abreast of these issues can be an awesome task. Daughters need strong relationships with their mothers and cultivating those connections may be a therapeutic undertaking for counselors, social workers, and family therapists.

Implications from the present study point toward an interrelationship of the mother-daughter relationship, self-esteem, and feminist consciousness that provide links to understanding how women make sense of themselves. According to Josselson (1987), psychological theory

concerning women and identity should not be based on the importance of a woman's separation from her mother. Theory about the separation-individuation process that underlies identity formation in women must appreciate that women never fully separate from their mothers and that affiliation through the relationship has an important role in the formation of identity in women (Fischer, 1991). Adolescent females appear to need a broader identity that blends both dimensions of separateness and connectedness (Lytle, Bakken & Romig, 1997). Results of this study support the association between women's sense of self and connection. Recognizing that there are differences in male and female development is relevant to professional counseling counselor education and contributes to our understanding of the unique differences between genders when we are conceptualizing ideas about "human" development and behavioral normalcy.

In adolescence, girls become more conflicted about achievement and competence, and data shows that this is the time during which sex-role stereotyping begins to increase and affects feelings of competence (Baruch, 1976). If the mother-daughter relationship affects self-esteem, then adolescent girls may benefit from their relationships with their mothers who value competence in their daughters. Mothers may be just the people to mediate these confusing issues for their daughters and therefore need to be encouraged to stay involved and to understand the potential of their tremendous influence within the relationship.

Programs created to empower girls are growing and appear to be an exciting way to build skills and create spaces to nurture adolescent girls' development (Lecroy & Daley, 2001). Thus it is important for these programs to be based on frameworks that are grounded in theory and research. The research claims that most, but not all mothers and daughters have positive and close relationships, and counselors and researchers alike know how important and significant this

relationship can be for the growing daughter. Research calls for the involvement of mothers with their daughters, and it would be useful for empowerment programs to invite and encourage mothers to engage in these activities along with their daughters.

In terms of clinical practice for counselors and therapists, self-esteem plays a central role in mental health (Polce-Lynch et al. 2001). Current views of the parent's role in the treatment of adolescents may be shifting and it is suggested that clinicians find ways to integrate parents into the child's therapy (Kovacs & Lohr, 1995). The link found in the current study connecting the mother-daughter relationship and daughters' self-esteem implies the possibility that mothers play an important role in their daughter's lives. It may be that mother can be a powerful therapeutic resource for daughters due to the saliency of the relationship and it may be important for clinicians to find ways to integrate mothers into daughters' therapy (Weingarten, 1998). Clinicians could be trained and work toward defusing conflict, promoting understanding, and the development of strategies for mothers to assist their adolescent daughters with the struggles they may be having that are often inherent at this phase of development. This in turn may not only improve the lives of daughters but also assist in the healthy development in families.

Additionally, it is important for clinicians when working with girls and women to understand the importance of the relational components of their lives. Girls and women develop important aspect of themselves through relationship and therefore in therapy the relationship will be of the utmost importance. Clinicians therefore must be cognizant of their own biases and ability to connect and relate to young women. This is a salient issue for counselor education. When training counselors for practice, counselor educators must encourage reflective practice as a tool to create optimal professionals. Theoretical underpinnings of counseling point to the therapeutic

relationship as the most salient aspect of therapy, and a unidirectional relationship or extremely directive techniques may be contraindicated for working with adolescent women.

School counselors, family counselors, educators, and parents could profit from information about the mother-daughter relationship simply by giving girls and women a sense of normalcy and pattern for their development. Issues once subsumed in the theoretical framework for male development may take on a new light and give women a much needed and substantiated framework of their own.

References

- Allen, K. R., & Walker, A. J. (1992). Attentive Love: A feminist perspective on the caregiving of adult daughters. *Family Relations, 41*, 284-289.
- Arbuckle, J. L. (1999). *AMOS 4.0 programming reference guide*. Chicago, IL: Small Water Corporation.
- Archer, S. L. (1992). A feminist approach to identity research. In G. R. Adams, T. P. Gullota & R. Montemayer (Eds.), *Adolescent identity formation*. Newbury Park, CA: Sage Publications.
- Bartky, S. (1975). Toward a phenomenology of feminist consciousness. *Social Theory and Practice, 3*, 425-439.
- Bandura, A., & Kuper, C. (1964). Transmission of patterns of self-reinforcement through modeling. *Journal of Abnormal and Social Psychology, 69*, 1-9.
- Bandura, A., & McDonald, F. (1963). Influence of social reinforcement and the behavior of models in shaping children's moral judgments. *Journal of Abnormal and Social Psychology, 67*, 274-281.
- Baruch, G. (1976). Girls who perceive themselves as competent: Some antecedents and correlates. *Psychology of Women Quarterly, 1*, 38-49.
- Baruch, G., & Barnett, R. C. (1983). Adult daughters' relationship with their mothers. *Journal of Marriage and the Family, 45*(3), 601-606.
- Benson, P. L., & Vincent, S. (1980). Development and validation of the Sexist Attitudes Toward Women Scale (SATWS). *Psychology of Women Quarterly, 5*, 276-291.
- Benson, P. L., & Vincent, S. (1980). *Sexist attitudes toward women scale*: Oxford: Blackwell Publishing.

- Beere, C. (1990). *Gender Roles: A handbook of tests and measures*. New York: Green Wood Press.
- Blascovich, J., & Tomaka, J. (1991). Measures of self esteem. In J. P. Robinson, P. R. Shaver, L. S. Wrightsman & F. M. Andrews (Eds.), *Measures of personality and social psychological attitudes, Volume I*. San Diego: Academic Press.
- Boisnier, A. (2003). Race and women's identity development: distinguishing between feminism and womanism among black and white women. *Sex Roles: A Journal of Research, 49*, 211-219.
- Boyd, C. J. (1989). Mothers and daughters: A discussion of theory and research. *Journal of Marriage and the family, 51*, 291-301.
- Bracken, B. (1993). *Assessment of Interpersonal Relations, examiner's manual*. Austin, TX: PRO-ED, Inc.
- Bracken, B. (1993). *Assessment of Interpersonal Relations, mother subscale*. Austin, Texas: PRO-ED, Inc.
- Bracken, B., & Mills, B. (1994). School counselors' assessment of self-concept: A comprehensive review of 10 instruments. *The School Counselor, 42*, 14-32.
- Buyse, T. M. (1999). The mother-daughter relationship and the development of daughters' feminist consciousness. *Dissertation Abstracts International, 60* (12B). (UMI No. 9954077).
- Chodorow, N. (1978). *The reproduction of mothering*. Berkeley: University of California Press.

- Charles, M., Frank, S., Jacobson, S., & Grossman, G. (2001). Repetition of the remembered past: Patterns of separation-individuation in two generations of mothers and daughters. *Psychoanalytic Psychology*, 18(4), 705-728.
- Coopersmith, S. (1967). *The antecedents of self-esteem*. California: Consulting Psychologists Press.
- Coopersmith, S. (1975). *Coopersmith Self-esteem inventory, adult form*. Redwood City, California: Mind Garden, Inc.
- Corey, G. (1977). *Theory and practice of counseling and psychotherapy (2nd edition)*. California: Brooks/Cole.
- de Beauvoir, S. (1952). *The second sex*. New York: Random House.
- Debold, E., Wilson, M., & Malave, I. (1993). *Mother daughter revolution: From betrayal to Power*. New York: Addison-Wesley.
- Douglass, J. (1989). A study of literature of mother-daughter relationships as it relates to self-esteem of the adult daughter. *Dissertation Abstracts International*, 50, 04A, (UMI No.0851).
- Eagle, C., & Colman, C., (1993). *All that she can be: Helping your daughter maintain her self-esteem*. New York: Simon and Schuster.
- Fine, M. (1992). *Disruptive Voices*. Michigan: The University of Michigan Press.
- Fischer, L. R. (1981). Transitions in the mother-daughter relationship. *Journal of Marriage and the Family*, 43,(3), 613-622.
- Fischer, L. R. (1991). Between mothers and daughters. *Marriage & Family Review*, 16(3-4), 237-248.

- Fischer, A., & Good, G. (1994). Gender, self and others: Perceptions of the campus environment. *Journal of Counseling Psychology, 41*(3), 343-355.
- Flax, J. (1978). The conflict between nurturance and autonomy in mother-daughter relationships and within feminism. *Feminist Studies, 4*(2), 172-189.
- Gall, M. D., Borg, W. R., & Gall, J. P. (1996). *Educational research: An introduction* (6th ed.). New York: Longman.
- Gilligan, C. (1982). *In a different voice*. Cambridge: Harvard University Press.
- Goldberg, J. E. (1995). The role of mutuality in mother-daughter relationships. *Affilia, 10*(1), 36-48.
- Goodrich, T. (1991). Women, power and family therapy: What's wrong with this picture? In T. Goodrich (Ed.), *Women and Power* (pp. 3-36). New York: W.W. Norton.
- Harter, S. (1996). Historical roots of contemporary issues involving self-concept. In B. Bracken (Ed.), *Handbook of self-concept* (pp.1-38). New York: John Wiley.
- Henderson-King, D., & Stewart, A. (1997). Feminist consciousness: Perspectives on women's experience. *Personality and Social Psychology Bulletin, 23*, 415-426.
- Henwood, K. (1997). Adult mother-daughter relationships: Two phases in the analysis of a qualitative project. *Feminism and Psychology, 7*(2), 255-263.
- Henwood, K., & Coughlan, G. (1993). The construction of closeness in the mother-daughter relationship across the lifespan. In N. Coupland & J. Nussbaum (Eds.), *Discourse and Lifespan Identity* (pp. 191-214). California: Sage Publications.
- Hollender, J. (1973). Self-esteem and parental identification. *Journal of Genetic Psychology, 122*, 3-7.

- Jordan, J., Kaplan, A., Miller, J., Stiver, I., & Surrey, J. (1991). *Women's growth in connection*. New York: Guilford Press.
- Josselson, R. (1987). *Finding herself. Pathways to identity development in women*. San Francisco: Jossey-Bass.
- Klem, L. (1995). Path analysis. In L. G. Grim & P. R. Yarnold (Eds.), *Reading and understanding multivariate statistics*. (pp. 65-99). Washington, DC: American Psychological Association.
- Kovacs, M., & Lohr, W. D. (1995). Research on psychotherapy with children and adolescents: An overview of evolving trends and current issues. *Journal of Abnormal Child Psychology*, 23(1), 11-30.
- Lambie, G. (2002) The contribution of ego development level to degree of burnout in school counselors.
Dissertation Abstracts International, 63(02A), (UMI No.3041698).
- LeCroy, C., & Daley, J. (2001). *Empowering adolescent girls: Examining the present and building skills for the future with the go grrrrls program*. New York: W. W. Norton.
- Lytle, L., Bakken, L., & Romig, C. (1997). Adolescent female identity development. *Sex Roles*, 37,(3/4),175-185.
- McMullin, J., & Cairney, J. (2004). Self-esteem and the intersection of age, class and gender. *Journal of Aging Studies*, 18(1), p.75-90.
- Meier, H. C. (1972). Mother-centeredness and college youths' attitudes toward social equality for women: Some empirical findings. *Journal of Marriage and the Family*, 34, 115-121.
- Miller, J. (1986). *Toward a new psychology of women*. Boston: Beacon Press.

- Morardi, B. & Subich, L. M. (2002). Perceived sexist events and feminist identity development attitudes: Links to women's psychological distress. *The Counseling Psychologist, 30*(1), 44-65.
- Notar, M. & McDaniel, S.A. (1986). Feminist attitudes and mother-daughter relationships in adolescence. *Adolescence, 21*, (81) 12-21.
- O'Reilly, A., & Abbey, S. (2000). *Mothers and Daughter: Connection, empowerment and transformation*. New York: Rowman & Littlefield Publishers, Inc.
- Papp, P. (2003). Gender, marriage and depression. In L. B. Silverstein & T. J. Goodrich (Eds.), *Feminist Family Therapy: Empowerment in Social Context*. (pp.211-224). Washington, D.C.: American Psychological Association.
- Parker, J., & Asher, S. (1987). Peer relations and later personal adjustment: Are low-accepted children at risk? *Psychology Bulletin, 102*, 357-389.
- Peterson, C. & Roberts, C. (2003). Like mother, like daughter: Similarities in narrative style. *Developmental Psychology, 39*(3), 551-562.
- Pipher, M. (1994). *Reviving ophelia*. New York: Ballantine Books.
- Polce-Lynch, M., Myers, B., Kleiwer, & Kilmartin, C. (2001). Adolescent self-esteem and gender: Exploring relations to sexual harassment, body image, media influence and emotional expression. *Journal of Youth and Adolescents, 30*(2), 225-244.
- Results of: AIR. (1995). *Mental measures yearbook*. Retrieved May 28, 2004, from <http://spweb.silverplatter.com>
- Results of: Coopersmith self-esteem inventories (1985) *Mental measures yearbook*. Retrieved May 8, 2004, from <http://spweb.silverplatter.com>

- Rich, A. (1976). *Of woman born: Motherhood as experience and institution*. New York: W. W. Norton & Co.
- Rich S. (1990). Daughters' views of their relationships with their mothers. In C. Gilligan, N. Lyons & T. Hanmer (Ed.), *Making connection* (pp. 258-272). Cambridge: Harvard University Press.
- Sanchez, D. & Crocker, J. (2005). How investment in gender ideals affects well-being: The role of external contingencies of self-worth. *Psychology of women quarterly*, 29, 63-77.
- Sanford, L., & Donovan, M. (1984). *Women and self-esteem: Understanding and improving the way we think and feel about ourselves*. New York: Penguin Books.
- Seems, S. (2001). Feminist family therapy: For heterosexual couples and families only? In K. A. May (Ed.), *Feminist family therapy* (pp. 29-52) Alexandria, VA: American Counseling Association.
- Sholomskas, D., & Axelrod, R. (1986). The influence of mother-daughter relationships on women's sense of self and current role choice. *Psychology of Women Quarterly*, 10, 171-182.
- Smith, C. (1999). I enjoy being a girl: Collective self-esteem, feminism, and attitudes toward women. *Sex Roles: A Journal of Research*.
- Smith, M., & Self, G. (1980). The congruence between mothers' and daughters' sex role attitudes: A research note. *Journal of Marriage and the Family*, 39, 563-574.
- SPSS. (1999). *SPSS base 10.0 applications guide*. Chicago: Marketing Department SPSS Inc.
- Stanley, L., & Wise, S. (1993). *Breaking out again: Feminist ontology and epistemology*. New York: Routledge.

- Stein, S., & Weston, L. (1982). College women's attitudes toward women and identity achievement. *Adolescence*, 17(68), p. 895-99.
- Stiener-Adair, S. (1990). Normal female adolescent development and the development of eating disorders. In C. Gilligan, N. Lyons & T. Hanmer (Eds.), *Making connection* (pp. 162-176). Cambridge: Harvard University Press.
- Stern, L. (1990). Conceptions of separation and connection in female adolescents. In C. Gilligan, N. Lyons & T. Hanmer (Ed.), *Making connection* (pp. 73-88). Cambridge: Harvard University Press.
- Thomas, J., & Daubman, K., (2001). The relationship between friendship quality and self-esteem in adolescent girls and boys. *Sex Roles: A Journal of Research*, 53-66.
- Tolman, A., Diekmann, K., & McCartney, K. (1989). Social connectedness and mothering: Effects of maternal employment and maternal absence. *Journal of Personality and Social Psychology*, 56(6), 942-949.
- Unger, R., & Crawford, M. (1992). *Women and gender: A feminist psychology*. Philadelphia: Temple University Press.
- Walters, M., Carter, B., Papp, P., & Silverstien, O. (1988). *The invisible web: Gender patterns in family relationships*. New York: The Guilford Press.
- Wastell, C. (1996). Feminist development theory: Implications for counseling. *Journal of Counseling & Development*, 74, 575-581.
- Weeks, M., Wise, G., & Duncan, C. (1984). The relationship between sex-role attitudes and career orientations of high school females and their mothers. *Adolescence*, 19(75), 595-607.

Weingarten, K. (1998). Sidelined no more: Promoting mothers of adolescents as a resource for their growth and development. In C. Coll, J. Surrey & K. Weingarten (Eds.), *Mothering against the odds: Diverse voices of contemporary mothers* (pp. 15-36). New York: The Guilford Press.

APPENDIX A

**COVER LETTER AND CONSENT FORM FOR PARENTS
AND CONSENT FORM
FOR PARTICIPANTS UNDER THE AGE OF 18**

Cover Letter and Consent Form for Parents and Consent Form for Participants

Marcy J. Douglass
 Doctoral Candidate
 College of William and Mary
 (757) 865-2784
mjdoug@wm.edu

Dear Parent,

My name is Marcy Douglass and I am a doctoral candidate in counselor education at the College of William and Mary. I am conducting a study to explore the relationship between the perception of the mother and daughter relationship, feminist consciousness and self-esteem in adolescent girls/ young women. This study may further our understanding of the mother-daughter relationship as it affects adolescent daughters.

If your daughter is between the ages of 17 and 19 and has a relationship with her mother or a woman in the role of mother, she will be invited to participate in this study. Your assistance would be greatly appreciated. By allowing your daughter to participate in this study, which involves completing a Demographic Survey, Assessment of Interpersonal Relationships, Mother Subscale, Sexist Attitudes Toward Women Scale and the Coopersmith Self-Esteem Inventory, you will allow me to collect valuable information for research pertaining to young women. I've designed the research packet to obtain the necessary data while taking a minimum amount of your daughter's time. The entire packet will take between 30-35 minutes to complete. Your daughter's responses will be held in the strictest confidence.

I want to inform you of your daughter's rights as a participant in this research and ask that you discuss these rights with your minor child if you decide to allow her to participate in the study. Participation in the study is voluntary and participants may refuse to answer any question that is asked, and may choose to withdraw at any time during the study. Also, anonymity for each participant taking part in this project is highly valued and will be maintained to the utmost limits of the law. In order to ensure anonymity only numbers will be placed on the research packets to code them. This study is not expected to involve any risk of harm greater than that encountered in daily life. Lastly, you or your daughter may report dissatisfactions with any aspect of this research project to the Chair of the Protection of Human Subjects Committee, Dr. Mike Deschenes, (757) 221-2778, mrdesc@wm.edu.

If you have any questions please do not hesitate to call or e-mail me.

Sincerely,

Marcy J. Douglass

By signing below I give consent for my daughter, _____ to participate in this research study.

Signature

date

Student Consent Form

***"AN EXPLORATION OF THE RELATIONSHIP BETWEEN
THE PERCEPTION OF THE MOTHER-DAUGHTER RELATIONSHIP,
FEMINIST CONSCIOUSNESS AND SELF-ESTEEM
IN THE ADOLESCENT/YOUNG ADULT DAUGHTER"***

I, (print name here) _____, am willing to participate in a study exploring the relationship between the perception of the mother and daughter relationship, feminist consciousness and self-esteem in adolescent girls/ young women. I understand that the study is being conducted by Marcy J. Douglass a doctoral candidate in counselor education at the College of William & Mary. My involvement in this study will be approximately 30-35 minutes.

As a participant in this study, I am aware that I will be asked to complete four research instruments:

- A Demographic Survey,
- Assessment of Interpersonal Relationships, Mother Subscale
- Sexist Attitudes Toward Women Scale
- Coopersmith Self-Esteem Inventory.

As a participant in this study, I am aware that:

- Participation is voluntary.
- I may refuse to answer any question that is asked.
- I may choose to withdraw at any time during the study.
- A copy of the results of the study will be e-mailed to me upon request.
- I may report dissatisfactions with any aspect of this research project to the Chair of the Protection of Human Subjects Committee, Dr. Mike Deschenes, (757) 221-2778, mrdesc@wm.edu.

By participating in this study, I understand that there are no obvious risks to my physical or mental health.

Confidentiality Statement

As a participant in this study, I am aware that all records will be kept confidential and my name will not be associated with any of the results of this study.

I fully understand the above statements, and do hereby consent to participate in this study.

Signature

date

****Please sign, date, and return one copy with your completed surveys. The second copy is for your records.***

APPENDIX B
CONSENT FORM

Consent Form

**Please sign, date, and return one copy with your completed surveys. The second copy is for your records.*

**"AN EXPLORATION OF THE RELATIONSHIP BETWEEN
THE PERCEPTION OF THE MOTHER-DAUGHTER RELATIONSHIP,
FEMINIST CONSCIOUSNESS AND SELF-ESTEEM
IN THE ADOLESCENT/YOUNG ADULT DAUGHTER"**

I, (print name here) _____, am willing to participate in a study exploring the relationship between the perception of the mother and daughter relationship, feminist consciousness and self-esteem in adolescent girls/ young women. I understand that the study is being conducted by Marcy J. Douglass a doctoral candidate in counselor education at the College of William & Mary. My involvement in this study will be approximately 30-35 minutes.

As a participant in this study, I am aware that I will be asked to complete four research instruments: the Demographic Survey, Assessment of Interpersonal Relationships, Mother Subscale, the Sexist Attitudes Toward Women Scale and the Coopersmith Self-Esteem Inventory.

As a participant in this study, I am aware: that participation is voluntary, that I may refuse to answer any question that is asked, and that I may choose to withdraw at any time during the study. I also understand that a copy of the results of the study will be e-mailed to me upon request. I am aware that I may report dissatisfactions with any aspect of this research project to the Chair of the Protection of Human Subjects Committee, Dr. Mike Deschenes, (757) 221-2778, mrdesc@wm.edu.

By participating in this study, I understand that there are no obvious risks to my physical or mental health.

Confidentiality Statement

As a participant in this study, I am aware that all records will be kept confidential and my name will not be associated with any of the results of this study.

I fully understand the above statements, and do hereby consent to participate in this study.

Signature

date

APPENDIX C
DEMOGRAPHIC SURVEY

Demographic Survey

Directions: Please read each question carefully and mark the number of the answer that best describes you or your Mother. There are no right or wrong answers so please answer every question. If a blank follows an answer please write in your answer.

1. Your age ...

- 17 years old (1)
 18 years old (2)
 19 years old (3)

2. The person I consider to be my Mother is my...

- Biological mother (1)
 Adoptive mother (2)
 Stepmother (3)
 Foster mother (4)
 Other Guardian or caretaker _____ (5)

3. The length of time in years I have had a relationship with the person I consider to be my Mother is.....

- 5 years (1)
 5-10 years (2)
 10-15 years (3)
 15+ years (4)

4. Your Mother's age

- 32-37 years (1)
 38-42 years (2)
 43-48 years (3)
 48-55 years (4)
 55+ years (5)

5. Your ethnicity

- White (1)
 Black or African American (2)
 American Indian and Alaska Native (3)
 Asian (4)
 Native Hawaiian and other Pacific Islander (5)
 Hispanic or Latino (of any race) (6)
 Some other race _____ (7)
 Two or more races _____ (8)

6. Your Mother's ethnicity

- White (1)
 Black or African American (2)
 American Indian and Alaska Native (3)
 Asian (4)
 Native Hawaiian and other Pacific Islander (5)
 Hispanic or Latino (of any race) (6)
 Some other race _____ (7)
 Two or more races _____ (8)

7. In your opinion, how would you rate this statement, "My mother believes that women and men should be treated equally politically, economically and socially."

- Strongly disagree (1)
 Disagree (2)
 Not sure (3)
 Agree (4)
 Strongly agree (5)

8. My Mother's education level is:

- Elementary School (1)
 High School (2)
 Technical School (3)
 Community College (4)
 Some college courses (5)
 College Degree (Bachelor's degree) (6)
 Some graduate school (7)
 Graduate degree (Master's degree) (8)
 Doctoral Degree (9)

9. My Mother's employment level is:

- Full-time (1)
 Part-time (2)
 Self-employed (3)
 Stay at home Mom (4)
 Unemployed (5)

For Office Use only Participant number:

- (0) (1) (2) (3) (4) (5) (6) (7) (8) (9)
 (0) (1) (2) (3) (4) (5) (6) (7) (8) (9)
 (0) (1) (2) (3) (4) (5) (6) (7) (8) (9)

APPENDIX D

ASSESSMENT OF INTERPERSONAL RELATIONS
MOTHER SUBSCALE ©

Copyright ©1993 by PRO-ED, Inc.

This scale was modified for a one-time use with the permission of the author, Dr. Bruce Bracken.

Assessment of Interpersonal Relations AIR
Bruce A. Bracken

Please rate the following statements according to how well they apply to your mother. Please rate each statement according to how you *honestly* feel. There are no right or wrong answers, so be sure you are honest with yourself as you rate each statement.

Mother Scale			
Strongly Disagree (SD)	Disagree (D)	Agree (A)	Strongly Agree (SA)

	SD	D	A	SA
1. I am really understood by my mother.	1	2	3	4
2. I like to spend time with my mother.	1	2	3	4
3. If I was bothered by a friend's behavior, I would tell my mother.	1	2	3	4
4. I am treated fairly by my mother.	1	2	3	4
5. I feel I am being used by my mother.	1	2	3	4
6. When I buy things, I value the opinion of my mother.	1	2	3	4
7. If I was worried about a friend doing drugs, I would talk to my mother.	1	2	3	4
8. When I am lonely, I seek the company of my mother.	1	2	3	4
9. I feel trust and stability in my relationship with my mother.	1	2	3	4
10. My relationship is stressful with my mother.	1	2	3	4
11. I am depended upon heavily by my mother.	1	2	3	4
12. I can express my true feelings when I am with my mother.	1	2	3	4
13. My happiness is affected by my mother.	1	2	3	4
14. It is important to me that I am accepted by my mother.	1	2	3	4
15. It is difficult to be myself when I am around my mother.	1	2	3	4
16. My personal values are like those of my mother.	1	2	3	4
17. When I am feeling good, I like to be around my mother.	1	2	3	4
18. I feel comfortable around my mother.	1	2	3	4
19. If I had questions about sex, I would ask my mother.	1	2	3	4
20. It is <i>not</i> easy to be honest with my mother.	1	2	3	4
21. I am accepted totally by my mother.	1	2	3	4
22. I am motivated to do my best my mother.	1	2	3	4
23. I am influenced most by my mother.	1	2	3	4
24. When I am in trouble, I talk with my mother.	1	2	3	4
25. I argue a lot with my mother.	1	2	3	4
26. I am really cared about by my mother.	1	2	3	4
27. I enjoy talking with my mother.	1	2	3	4
28. I respect my mother.	1	2	3	4
29. When I have concerns about my future, I talk with my mother.	1	2	3	4
30. I am criticized most by my mother.	1	2	3	4
31. I want to be like my mother.	1	2	3	4
32. I feel bad when things are not going well for my mother.	1	2	3	4
33. I trust the motives of my mother.	1	2	3	4
34. I feel I can tell secrets to my mother.	1	2	3	4
35. I frequently am disappointed by my mother.	1	2	3	4

For Office Use only Participant number:

0 1 2 3 4 5 6 7 8 9

0 1 2 3 4 5 6 7 8 9

0 1 2 3 4 5 6 7 8 9

APPENDIX E
COOPERMITH SELF-ESTEEM INVENTORY,
ADULT VERSION ©

Copyright © 1975 by Stanley Coopersmith

Coopersmith Inventory Adult form

Stanley Coopersmith, Ph.D.

On this form you will find a list of statements about feelings. If a statement describes how you usually feel, mark the ① "Like Me." If a statement does not describe how you usually feel, mark ② "Unlike Me." There are no right or wrong answers. Begin at the top of the page and mark all 25 items.

**Like
me****Unlike
Me**

- | | | |
|---|---|---|
| 1. Things usually don't bother me. | ① | ② |
| 2. I find it very hard to talk in front of a group. | ① | ② |
| 3. There are lots of things about myself I'd change if I could. | ① | ② |
| 4. I can make up my mind without too much trouble. | ① | ② |
| 5. I'm a lot of fun to be with | ① | ② |
| 6. I get upset easily at home. | ① | ② |
| 7. It takes me a long time to get used to anything new. | ① | ② |
| 8. I'm popular with persons my own age. | ① | ② |
| 9. My family usually considers my feelings. | ① | ② |
| 10. I give in very easily. | ① | ② |
| 11. My family expects too much of me. | ① | ② |
| 12. It's pretty tough to be me. | ① | ② |
| 13. Things are all mixed up in my life. | ① | ② |
| 14. People usually follow my ideas. | ① | ② |
| 15. I have a low opinion of myself. | ① | ② |
| 16. There are many times when I would like to leave home. | ① | ② |
| 17. I often feel upset with my work. | ① | ② |
| 18. I'm not as nice looking as most people. | ① | ② |
| 19. If I have something to say, I usually say it. | ① | ② |
| 20. My family understands me. | ① | ② |
| 21. Most people are better liked than I am. | ① | ② |
| 22. I usually feel as if my family is pushing me. | ① | ② |
| 23. I often get discouraged with what I am doing. | ① | ② |
| 24. I often wish I were someone else. | ① | ② |
| 25. I can't be depended on. | ① | ② |

For Office Use only Participant number:

① ② ③ ④ ⑤ ⑥ ⑦ ⑧ ⑨

① ② ③ ④ ⑤ ⑥ ⑦ ⑧ ⑨

① ② ③ ④ ⑤ ⑥ ⑦ ⑧ ⑨

APPENDIX F
SEXIST ATTITUDES TOWARD
WOMEN SCALE ©

Copyright© Blackwell Publishing

Sexist Attitudes Toward Women Scale

Directions: Read each statement carefully. Rank each item from ① (strongly disagree) to ⑦ (strongly agree). Mark your number after each statement. Please answer honestly as there are not right or wrong answers.

Strongly Disagree ①	Moderately Disagree ②	Slightly Disagree ③	Neither Agree Nor Disagree ④	Slightly Agree ⑤	Moderately Agree ⑥	Strongly Agree ⑦
-------------------------------	---------------------------------	-------------------------------	--	----------------------------	------------------------------	----------------------------

	SD	MD	SD	NA/ ND	SA	MA	SA
1. If I had a daughter, I would discourage her from working on cars.	①	②	③	④	⑤	⑥	⑦
2. I get angry at women who complain that American society is unfair to them.	①	②	③	④	⑤	⑥	⑦
3. Our society puts too much emphasis on beauty, especially for women.	①	②	③	④	⑤	⑥	⑦
4. Women shop more than men because they can't decide what to buy.	①	②	③	④	⑤	⑥	⑦
5. Most women who join protests for women's rights do it just for the thrill of protesting.	①	②	③	④	⑤	⑥	⑦
6. It bothers me if a man is interested in a woman only if she is pretty.	①	②	③	④	⑤	⑥	⑦
7. It bothers me to see a man being told what to do by a woman.	①	②	③	④	⑤	⑥	⑦
8. I think having children is a woman's greatest fulfillment.	①	②	③	④	⑤	⑥	⑦
9. Men are instinctually more courageous than women in the face of danger.	①	②	③	④	⑤	⑥	⑦
10. I think that women should spend a lot of time trying to be pretty.	①	②	③	④	⑤	⑥	⑦
11. I can really understand why there needs to be a women's liberation movement.	①	②	③	④	⑤	⑥	⑦
12. Women rely more on intuition and less on reason than men do.	①	②	③	④	⑤	⑥	⑦
13. Women should not be as sexually active before marriage as men.	①	②	③	④	⑤	⑥	⑦
14. Men are just as easily influenced by others as women are.	①	②	③	④	⑤	⑥	⑦
15. I think women should be more concerned about their appearance than men.	①	②	③	④	⑤	⑥	⑦
16. Men will always be the dominant sex.	①	②	③	④	⑤	⑥	⑦
17. I dislike it when men treat women as sexual objects.	①	②	③	④	⑤	⑥	⑦
18. I think that the husband should have the final say when a couple makes a decision.	①	②	③	④	⑤	⑥	⑦
19. Women should have all the same rights as men.	①	②	③	④	⑤	⑥	⑦
20. I see nothing wrong with a woman who doesn't like to wear skirts or dresses.	①	②	③	④	⑤	⑥	⑦
21. Women should be handled gently by men because they are so delicate.	①	②	③	④	⑤	⑥	⑦
22. Women should be prepared to oppose men in order to obtain equal status.	①	②	③	④	⑤	⑥	⑦
23. I am suspicious of a woman who would rather work than have children.	①	②	③	④	⑤	⑥	⑦
24. I think that women are naturally emotionally weaker than men.	①	②	③	④	⑤	⑥	⑦
25. On the average, women are as intelligent as men.	①	②	③	④	⑤	⑥	⑦
26. If a husband and wife both work full time, the husband should do half of the housework.	①	②	③	④	⑤	⑥	⑦
27. I like women who are outspoken.	①	②	③	④	⑤	⑥	⑦
28. I see nothing wrong with men whistling at shapely women.	①	②	③	④	⑤	⑥	⑦
29. It bothers me more to see a woman who is pushy than a man who is pushy.	①	②	③	④	⑤	⑥	⑦
30. A working wife should not be hired for a job if there is a family man who needs it.	①	②	③	④	⑤	⑥	⑦
31. Women can handle pressure just as well as men can when making a decision.	①	②	③	④	⑤	⑥	⑦
32. Men are naturally better than women at mechanical things.	①	②	③	④	⑤	⑥	⑦
33. A woman's place is in the home.	①	②	③	④	⑤	⑥	⑦
34. I think that many TV commercials present a degrading picture of women.	①	②	③	④	⑤	⑥	⑦
35. I think that a woman could do most things as well as a man.	①	②	③	④	⑤	⑥	⑦
36. I think that men are instinctually more competitive than women	①	②	③	④	⑤	⑥	⑦
37. I think women have a right to be angry when they are referred to as a "chick."	①	②	③	④	⑤	⑥	⑦
38. It would make me feel awkward to address a woman as "Ms."	①	②	③	④	⑤	⑥	⑦
39. I see nothing wrong with men who are primarily interested in a woman's body.	①	②	③	④	⑤	⑥	⑦
40. If I had a choice, I would just as soon work for a woman as for a man.	①	②	③	④	⑤	⑥	⑦

For Office Use only Participant number:

① ② ③ ④ ⑤ ⑥ ⑦ ⑧ ⑨
 ① ② ③ ④ ⑤ ⑥ ⑦ ⑧ ⑨
 ① ② ③ ④ ⑤ ⑥ ⑦ ⑧ ⑨