

Reports

---

9-1-1984

## Squid Nets of the Mid-Atlantic

Philip Cahill  
*Virginia Institute of Marine Science*

W. E. Mansfield  
*Virginia Institute of Marine Science*

Follow this and additional works at: <https://scholarworks.wm.edu/reports>



Part of the [Aquaculture and Fisheries Commons](#)

---

### Recommended Citation

Cahill, P., & Mansfield, W. E. (1984) Squid Nets of the Mid-Atlantic. Marine Resource Advisory No. 27. Virginia Institute of Marine Science, College of William and Mary. <http://dx.doi.org/doi:10.21220/m2-5psy-9t33>

This Report is brought to you for free and open access by W&M ScholarWorks. It has been accepted for inclusion in Reports by an authorized administrator of W&M ScholarWorks. For more information, please contact [scholarworks@wm.edu](mailto:scholarworks@wm.edu).



VIMS

# Marine Resource Advisory

No. 27

VIRGINIA SEA GRANT MARINE ADVISORY SERVICE AT VIMS/WILLIAM & MARY

SEPTEMBER 1984

## Squid Nets of the Mid-Atlantic

by Philip Cahill and W. E. Mansfield

This publication illustrates squid nets commonly used along the mid-Atlantic coast. Within recent years East Coast trawl fishermen have expressed a strong interest in "High Rise" or "Fly" nets for the squid fishery (*Illex* and *Loligo*). Until the early 1980s, squid was primarily harvested by foreign vessels for a European market and was considered an incidental catch for American boats. In the early 1960s fishermen used a wide variety of gear to catch squid, including whitefish trawls modified for larger mesh. Now High Rise nets are replacing those like the original "Yankee 36 trawl" or its modified version, the URI 41. High Rise nets are constructed with two- and four-panel sections with high vertical openings where the head rope can achieve heights of 35 to 50 feet.

Because squid generally school close to the bottom, nets must have sufficient vertical rise in the head rope and must be able to be towed at speeds in excess of three knots. In 1976 the German net maker H. H. Engel stated that the best trawl gear for squid is a medium opening bottom trawl

*Illex illecebrosus*

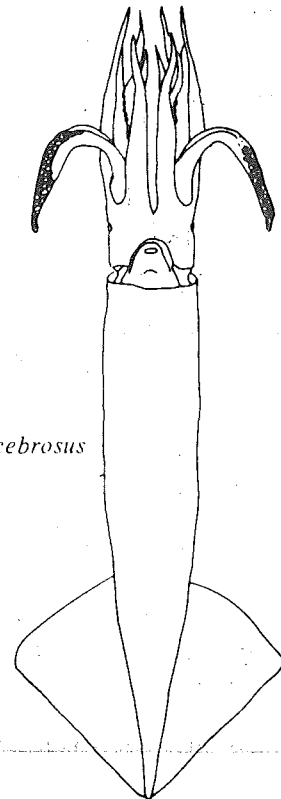

with a 20-23 feet vertical opening with long wings. Mesh sizes should decrease, Engel says, from 5 to 2 inches stretched in the cod end (FAO Fisheries Report, No. 170, Suppl. 1).

## PERSONAL OBSERVATION

Co-author Capt. W. E. "Bill" Mansfield remembers the first time he observed use of large-mesh, High Rise nets on the East Coast. Mansfield is a veteran skipper, having fished out of Gloucester, Mass., Cape May, N.J., and Hampton, Va., for forty years. He is now a technical advisor for the Virginia Sea Grant Marine Advisory Services at the Virginia Institute of Marine Science.

"It is my belief that the first one to be tried on the East Coast was by a small dragger out of Cape May, N.J., also that it was called the 'Point Pleasant wing trawl.' About 1960 a few draggers out of Hampton, Va., were fishing for porgies in an area between Winter Quarter and Five Fathom Bank. I was one of them and remember this Cape May boat skippered by Gus Genovese coming there and catching a lot more fish than anyone else. He said that he was using one of those new type nets. I bought one later on. I found it to be made of 8-inch webbing in the wings, square, and bellies; 4-inch in the lower part of the bellies; and 3-inch in the extension and cod end.

"The first time I used one was in the early 70s. I was fishing on the northern side of Jeffreys Ledge in an area about halfway between Gloucester (Mass.) and Portland. I found it to be much better than the Yankee 36 that I always used, but soon found out that it was easily damaged. I did make a few tows with it before it was damaged beyond repair. That is a bad feature of these nets; they are not suited for hard bottom unless modified for using some type of roller gear. I do feel they would do very well in the taking of whiting or any other species in the good bottom in such parts as the northern edge of Georges Bank. A method that proved to be very successful when we were after redfish on the very worst bottom known as 'Stone Fence' was to use extra length roller chains (20-24 inches) and use floats on the sweep or

foot rope. Keeping the gear in one piece was the hard thing."

## PRESENT GEAR

Today successful squid gear has 64-inch mesh in the fore part, decreasing to 8-inch, 4-inch, a long extension of 3-inch (300 meshes deep), to a cod end of 2-inch mesh with a small mesh liner, under 1/4-inch to prevent escape. This configuration allows a wider opening (138 feet on the foot rope). The large mesh reduces drag to allow a higher vertical opening, faster towing speed and efficient use of the vessel's power.

## REGIONAL PREFERENCES

Albert and Gus Genovese of Cape May, N.J., were among the first and remain the most consistent users of High Rise nets. The Genovese brothers prefer the 64-inch body composed of 1/4-inch nylon, hand-tied mesh added to 8-inch, then 4-inch, then an extension of 3-inch, all composed of 30 thread and a 2-inch cod end of 84 thread. They originally experimented with 8-inch mesh in the fore part of the net and found this was outproducing their other nets. By experimenting with 16-, 32-, and 64-inch mesh in the fore part of the net, they discovered that each increase in mesh size would subsequently lead to greater productivity. They are presently contemplating constructing a net out of 10-foot mesh in the fore part.

North Carolina and Virginia fishermen prefer the 16-inch High Rise nets of machine-made twine in the fore part of the net. Gib Sadler of Hobucken, N.C., and Roger Harris of Atlantic, N.C., construct nets of this type at their shops. Sadler has installed machines and makes all of his own webbing and twine. The largest machine-made mesh that he is aware of domestically and abroad is 32-inch. Sadler believes the predecessor of today's High Rise nets was the "Irish Wing Trawl."

## CARE OF HIGH RISE NETS

Fishermen agree that setting and retrieving large-mesh nets require special care. A net reel and stern ramp are mandatory for efficient handling. Knots from mending the large meshes tend to cause most foul-ups. Use of four-holed floats has minimized foul-ups of floats caught under mesh bars. These floats have two holes at the bottom for seizing to the head rope and two at the top for receiving a through rope. Large hauls of 40-60 thousand pounds are quite common for Illex. Therefore, it is imperative to rig nets to bear unusual strain. Strong rib and strengthening line should be included. Fishermen should presoak lines to avoid any shrinkage problems and should take great care to lace and size them to the webbing properly.

### NET DIAGRAMS

High Rise nets used along the mid-Atlantic coast to catch squid include the Irish Wing Trawl, the Cape May 64-foot High Rise, Roger Harris' 16-inch High Rise, and Gib Sadler's 8- and 16-inch High Rise nets.

These net designs are intended for fishermen, net makers, and fishing gear technologists skilled in the construction and operation of fishing gear. Mounting, hanging or joining of netting, make-up of cod ends, splitting bags, and rigging techniques in general are subject to fishing conditions. These specifics of workmanship, vessel features, and personal opinion have been left to the judgment of the user.

Essential dimensions are provided, and as far as possible, the main design drawings are to scale. General outline drawings of complete gear, which are included for understanding, and detail drawings of components are mostly not to scale.

No preference of nets or net makers is implied.

## CAPE MAY 64-INCH HIGH RISE NET

The Cape May High Rise or Rope Net is extremely popular with New Jersey and Virginia fishermen for Illex squid and porgies (Stenotomus chrysops or scup). It is not a true rope trawl (such as the Polish rope trawl, which uses ropes instead of mesh); its name is derived from the large, 64-inch mesh in its fore part. The meshes are handmade from 1/4-inch nylon or dacron. The upper section (Figure 1) consists of a panel 35 meshes long and 5 meshes deep. This includes both bottom belly (3 meshes) and square (2 meshes), as well as the lower section which is also 35 meshes long, but only 3 meshes in depth.

The high vertical opening or lift is supplied by the "step-ups" or corner meshes. These are constructed by leaving 5 meshes for the centers in each panel. Beginning with the third mesh on each side of the center mesh, the mesh is attached toward the end of the panel. When the end is reached, a bar is made outwards and then again towards the center. When the 5 meshes that complete the corners are made, all bars on both the hanging and joining edges of the wings are made until the desired length is completed.

The net is then ready to be hung to its head rope and foot rope, in this particular design, 86 and 106 feet, respectively. A larger net can be constructed by simply adding meshes and bars. The top hangings are 10 feet on center. The center mesh is attached to the exact center of the head rope, and 2 meshes on either side of center are hung 30 inches apart. The corners are fit into 18 feet by hanging each mesh 43 inches apart and then each bar accordingly. The wings are hung into 20 feet which allows for 30 inches per bar. The bottom (Figure 2) is the same as the top. Additional bars that compensate for the square allow the wings to hang 30 feet.

Bottom characteristics should determine the amount and size of chain

to be used. When heavily chained, the net is prone to dig up mud lumps and soft bottom. A good rule of thumb is that too little is better than too much chain. The rib lines should be constructed of at least 1-inch nylon or of a material of equivalent strength and should be attached in a manner that will allow for stretching. As in any net the lines should take the strain off the webbing.

Figure 3 shows the Cape May headrope and provides the approximate measurements for the hanging and distribution of meshes and bars. The center mesh is hung to the center of the headrope. The remaining mesh should be spaced to 26 inches and hung accordingly. For quarter sections, each mesh or point is hung to 43 inches. Then each bar or three-legger is hung 10 inches from each mesh or point. (5 X 43" = 215"; 18' = 216"). Eight bars of the wing are hung to 30 inches. (20' = 240"; 8 X 30" = 240"). Some nets are also hung by allowing for an additional 6 feet on either end of the head rope.

The lower section (Figure 4), 106 feet deep, is the same as the top except wings hang to 30 feet. Some fishermen prefer the corner wings of step-ups to be made 1:1, 2:1, 3:1 instead of the 5 X 1:1 method. Also, additional center meshes are added. Some nets of this type have increased hanging lengths to as much as 118 feet by 138 feet.

The Cape May net needs a vessel of 600 HP or more.

#### **IRISH WING TRAWL**

Bill Mansfield and Gib Sadler of Cash Corners Net Shop believe that the Irish Wing Trawl is the predecessor for modern large-mesh squid trawls. Sadler has not constructed a net of this configuration in the last few years, but it is his opinion, as well as the authors', that a net of this design would be extremely effective in harvesting squid and other off-bottom species.

Sadler has provided the following measurements for construction. The top wings (Figure 5) are 24 feet, 10 inches, for a total of 49 feet, 8 inches, and are hung tight to those measurements. The step-ups, or as Sadler calls them, "gussets," are 17 feet per side for a total of 34 feet. These are hung slack into 15 feet for a combined total of 30 feet. The top square is 12 feet, and one-third of slack is recommended for a total of 8 feet. The total top measurement is 95 feet, 8 inches, and this is hung into 87 feet, 8 inches.

The bottom wings (Figure 6) are 37 feet, 8 inches, for a combined length of 75 feet, 4 inches. Like the top wings, they are hung tight to those measurements. The step-ups or gussets are also the same as the top and are again hung 15 feet to a side for a total of 30 feet. The bottom belly is 10 feet and is hung slack into 6 feet, 8 inches. Total bottom length is 119 feet, 4 inches, and is hung slack into 12 feet. This net can have a maximum vertical rise of 20 feet, 4 inches, depending on the amount of floats, door size and vessel horsepower.

The net is best suited for a vessel of 500 HP range.

#### **ROGER HARRIS 16-INCH HIGH RISE**

Roger Harris makes a 16-inch High Rise net at his net shop in Atlantic, N.C. Carolina and Virginia Capes fishermen use this particular design. This net has the highest vertical rise of designs described in this publication and can theoretically achieve a height of 68 feet, 8 inches. Net sounders have indicated head-rope heights in excess of 50 feet while towing.

Harris recommends top wings (Figure 7) of 38 feet, 8 inches, on a side for a combined length of 77 feet, 4 inches. Harris hangs his wings tight to those measurements. Unlike Gus Genovese and Gib Sadler, Harris refers to his step-ups as "queers." The step-ups are 13

feet, 4 inches, for a total of 26 feet, 8 inches. These should be hung slack into 10 feet for each wing for a combined total of 20 feet. The top square is 29 feet, 4 inches, and is hung into 19 feet, 8 inches. The total top measurement is 133 feet, 4 inches, and is hung slack to fit 117 feet.

For the bottom measurements (Figure 8) the side wings are 51 feet, 8 inches, for a combined length of 103 feet, 4 inches. However, unlike the top, the bottom is hung with a small amount of slack into 100 feet. The bottom step-ups are the same as the top and hang into 20 feet. The belly is 12 feet and is hung with a third of slack into 8 feet. The bottom has a combined length of 142 feet and is hung into 128 feet.

A vessel should be in excess of 600 HP to reach proper towing speeds.

#### **CASH CORNER 8-INCH HIGH RISE NET**

The Cash Corner 8-inch High Rise Net is designed and manufactured by Gib Sadler of the Cash Corner Net Shop of Hobucken, N.C. Carolina fishermen and Virginia draggerman also use Sadler's nets.

For the top of his 8-inch net (Figure 9), the side wings are 26 feet, 8 inches, for a total of 53 feet, 4 inches, which is hung tight into its full length. The step-ups are 18 feet, 3 inches, for a total of 36 feet, 6 inches, and these are hung slack into 15 feet for a total of 30 feet. The top square measures 15 feet, 4 inches, and is hung slack into 11 feet, 4 inches. The total top measurement is 105 feet, 2 inches, and is hung into a total of 94 feet, 8 inches.

For the bottom, the side wings are 36 feet, 8 inches, for a total of 73 feet, 4 inches, and are hung tight to these lengths. The step-ups are the same as the top section, 18 feet, 3 inches, for a total of 36 feet, 6 inches, and these are hung slack into 15

feet and 30 feet. The bottom belly is 10 feet, 8 inches, and is hung slack into 9 feet, 4 inches. The total bottom length is 120 feet, 6 inches, and it is hung into 112 feet, 8 inches.

The Cash Corner 8-inch net has a maximum vertical rise of 36 feet, and 500 HP or more is recommended for the towing vessel.

#### **CASH CORNER 16-INCH HIGH RISE NET**

The Cash Corner 16-inch High Rise, like the 8-inch, is designed and manufactured by Gib Sadler's Cash Corner Net Shop of Hobucken, N.C. This net is used in Virginia and North Carolina for both squid and finfish.

For the top of his 16-inch net (Figure 10), the side wings are 38 feet, 8 inches, for a total of 77 feet, 4 inches, which are hung tight into its full length. The step-ups are 16 feet, 8 inches, for a total of 33 feet, 4 inches, and these are hung slack into 15 feet for a total of 30 feet. The top square is 18 feet, 8 inches, and is hung slack into 15 feet. The total top measurement is 129 feet, 4 inches, and is hung into a total of 122 feet, 4 inches.

For the bottom, the side wings are 48 feet for a total of 96 feet and are hung tight into this length. This is the only net presented where the bottom step-ups are hung the same as the top. The bottom belly is also hung slack into 15 feet. The total bottom length of 148 feet is hung slack into 141 feet.

The Cash Corner 16-inch net has a maximum vertical rise of 58 feet, 8 inches, and a minimum of 600 HP is recommended. It should be noted that the Cash Corner 16-inch and the Roger Harris 16-inch nets are quite similar when the plans are laid side by side.

FIGURE 1  
CAPE MAY 64"  
Top Wings & Belly

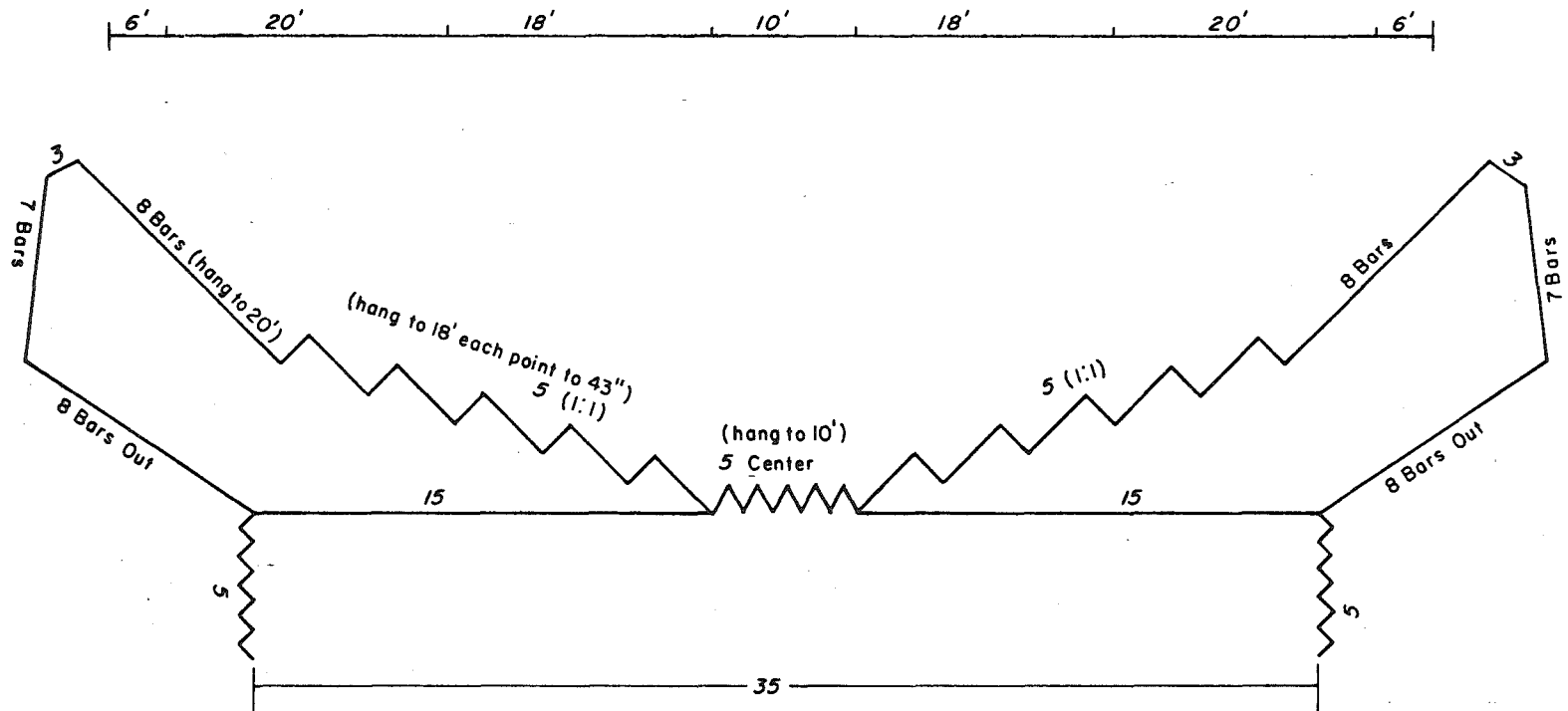

FIGURE 2  
CAPE MAY 64"  
Bottom Wings and Belly

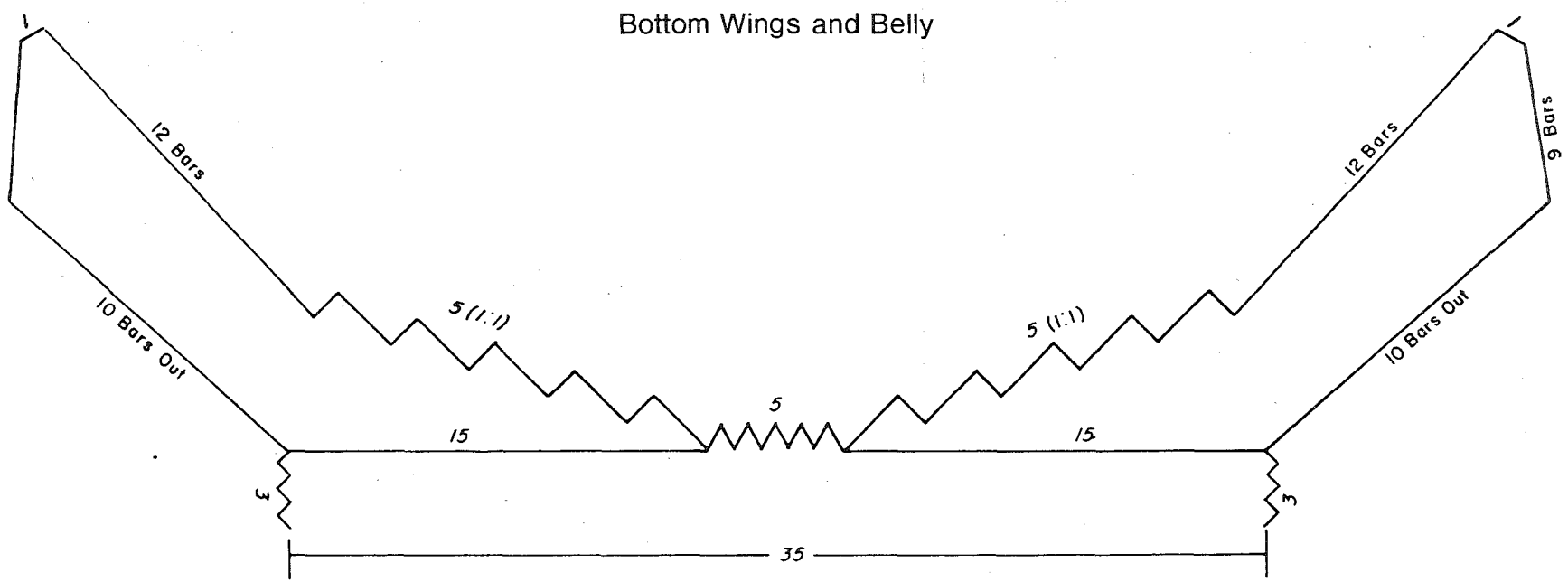
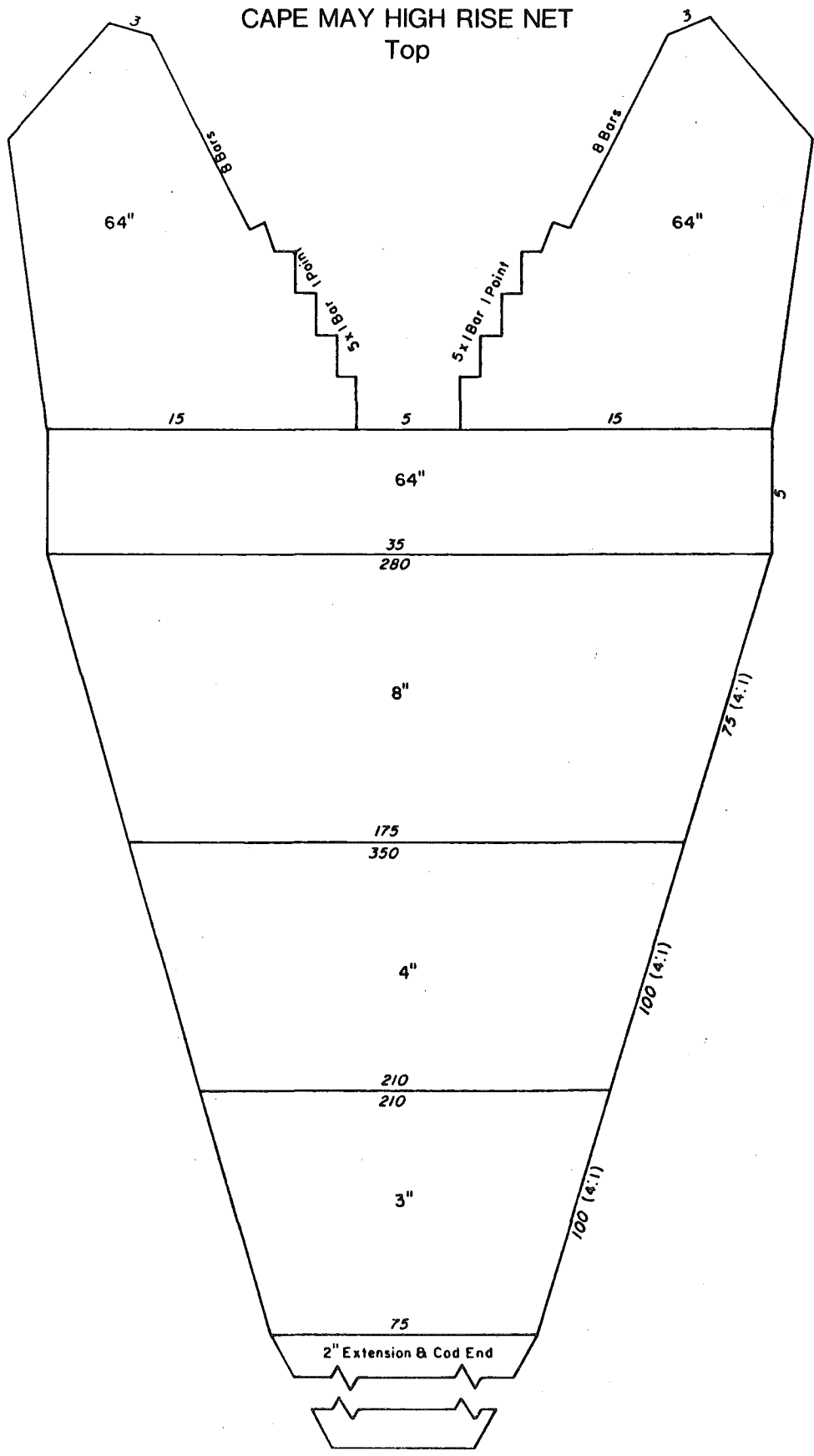



FIGURE 3

CAPE MAY HIGH RISE NET  
Top



Head Rope 86'  
Foot Rope 106'  
Vertical Rise 32'  
Hp 600

FIGURE 4  
 CAPE MAY HIGH RISE NET  
 Bottom

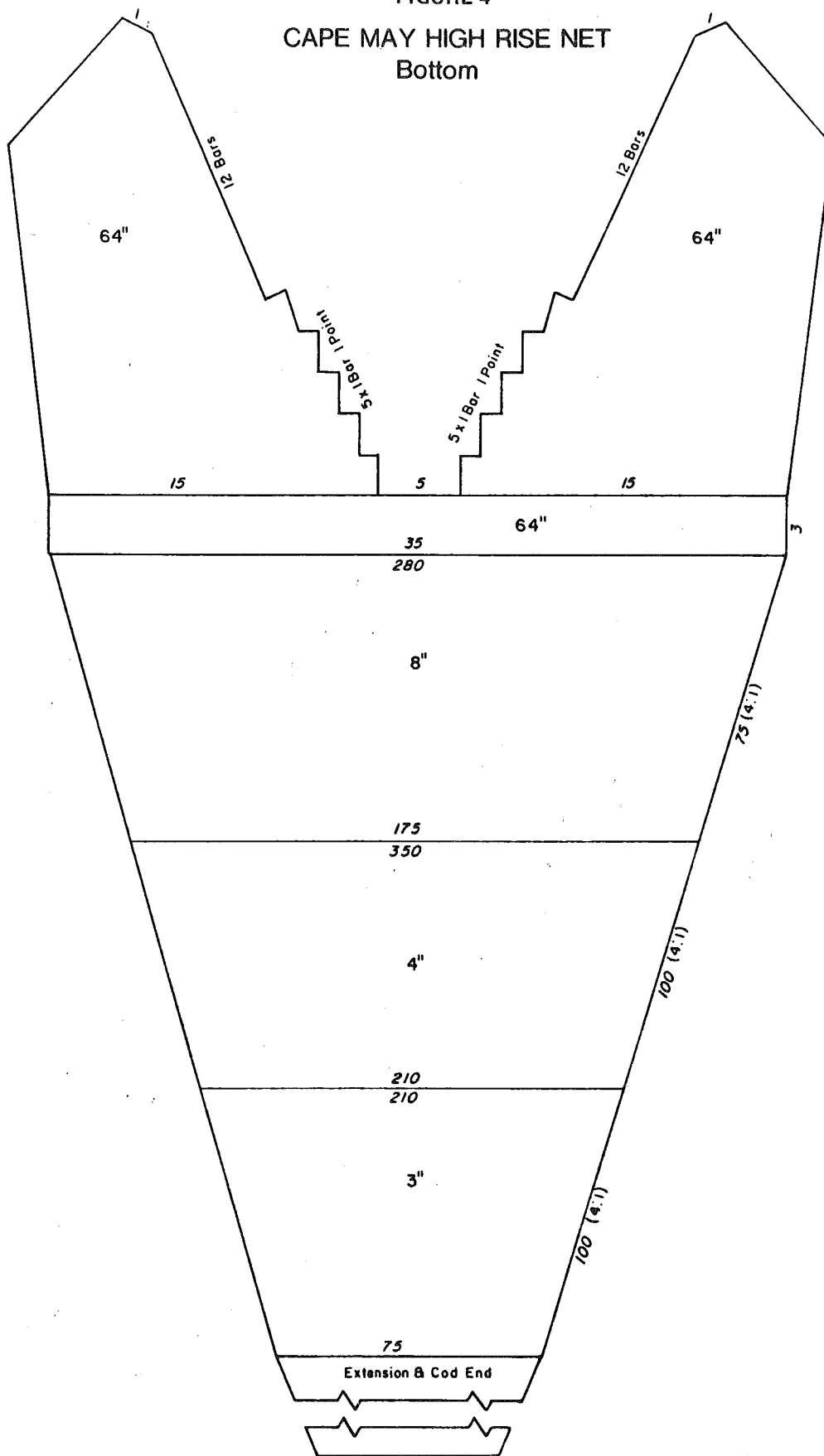
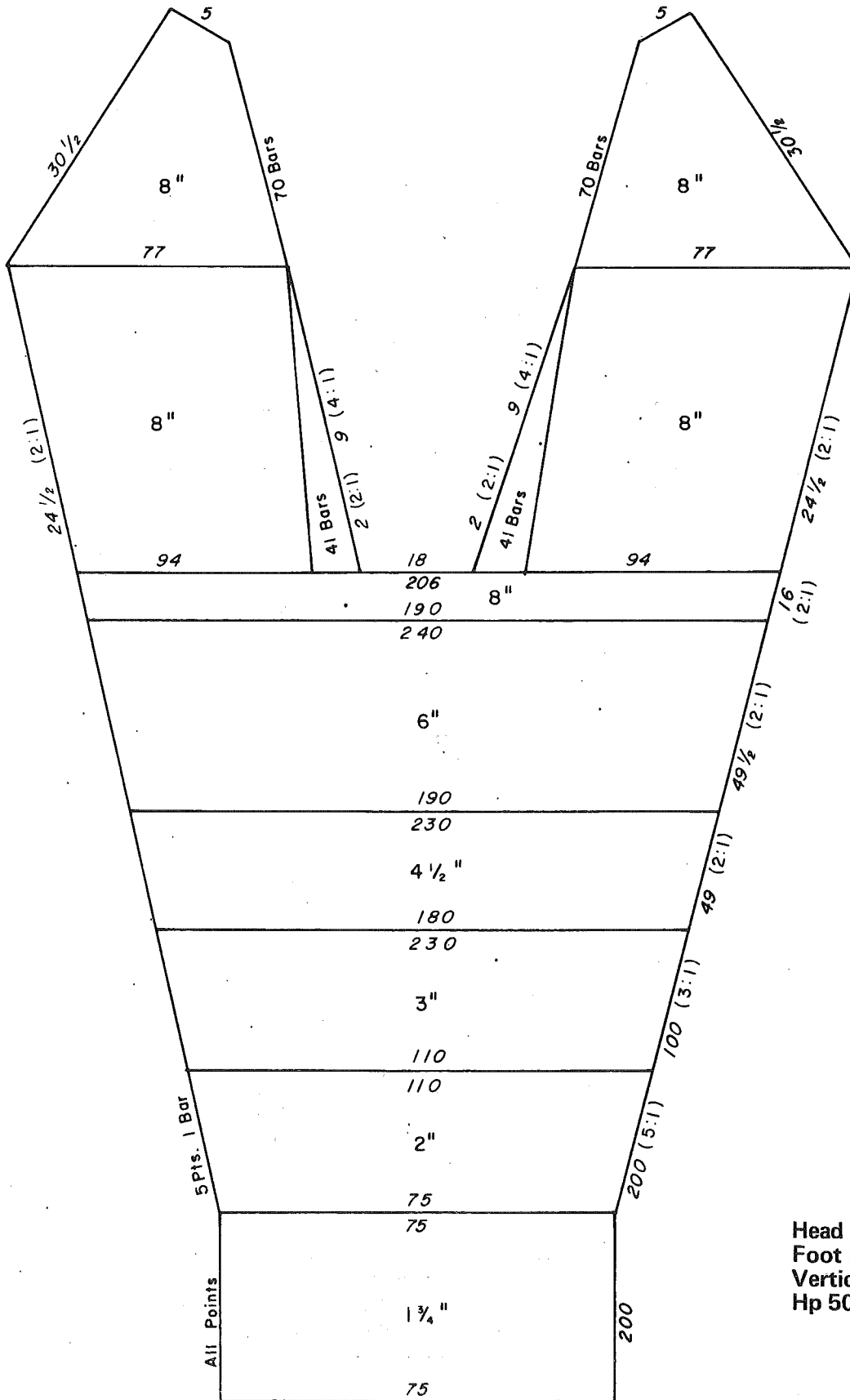

FIGURE 5  
IRISH WING TRAWL  
Top



Head Rope 87' 8"  
Foot Rope 112'  
Vertical Rise 20' 4"  
Hp 500

FIGURE 6  
IRISH WING TRAWL  
Bottom

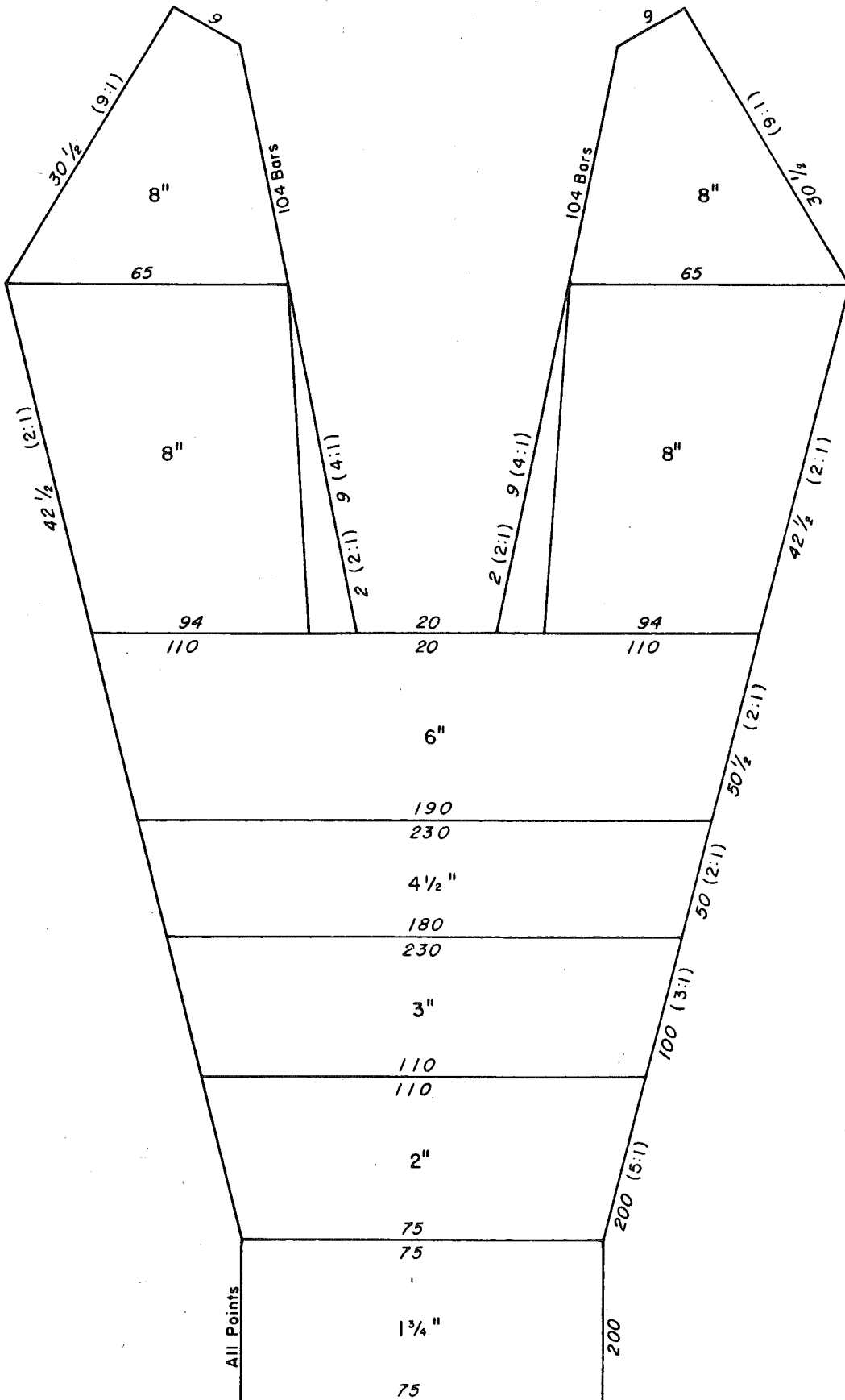
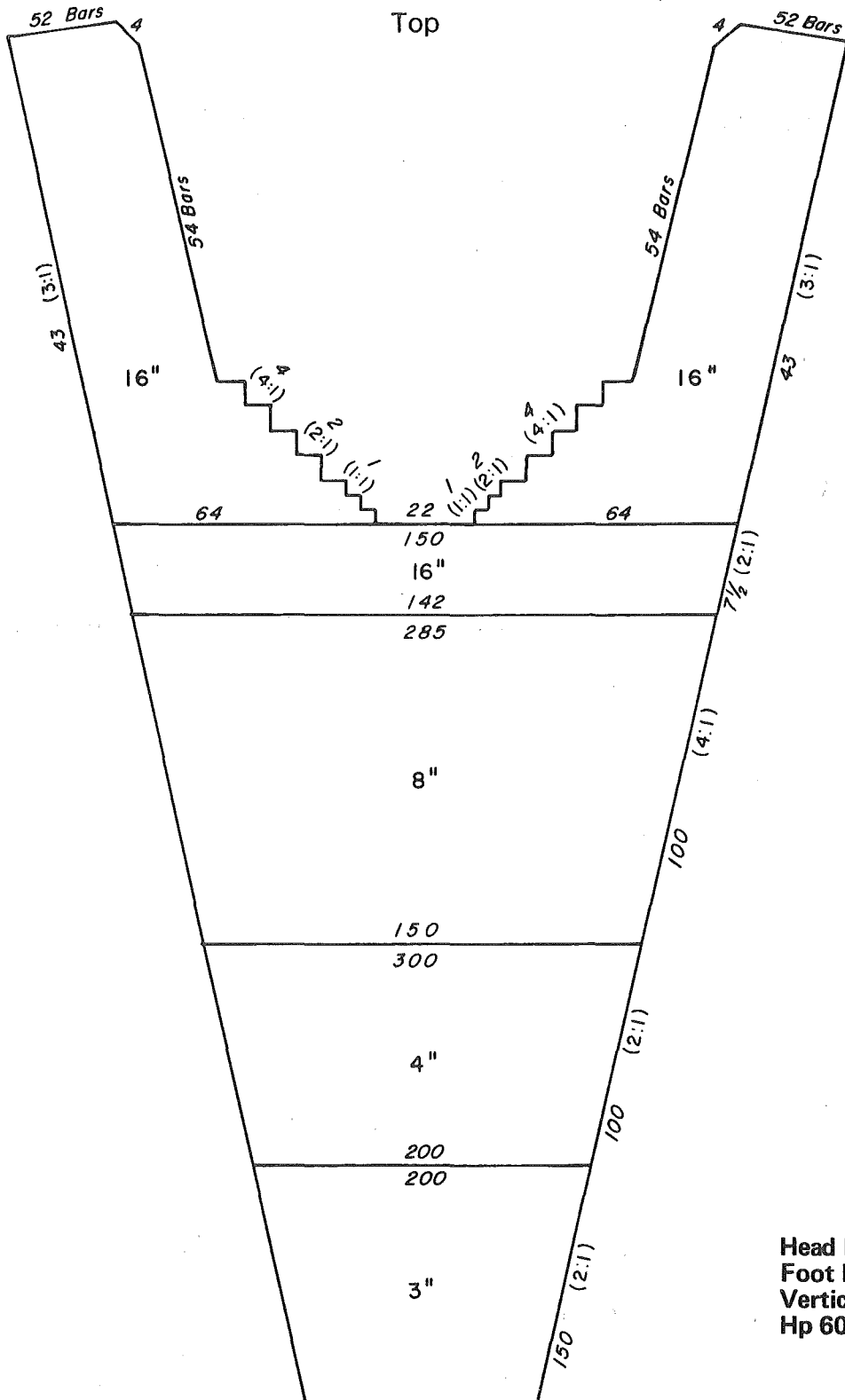

FIGURE 7  
 ROGER HARRIS 16" HIGH RISE



Head Rope 117'  
 Foot Rope 128'  
 Vertical Rise 68' 8"  
 Hp 600

FIGURE 8  
 ROGER HARRIS 16" HIGH RISE

Bottom

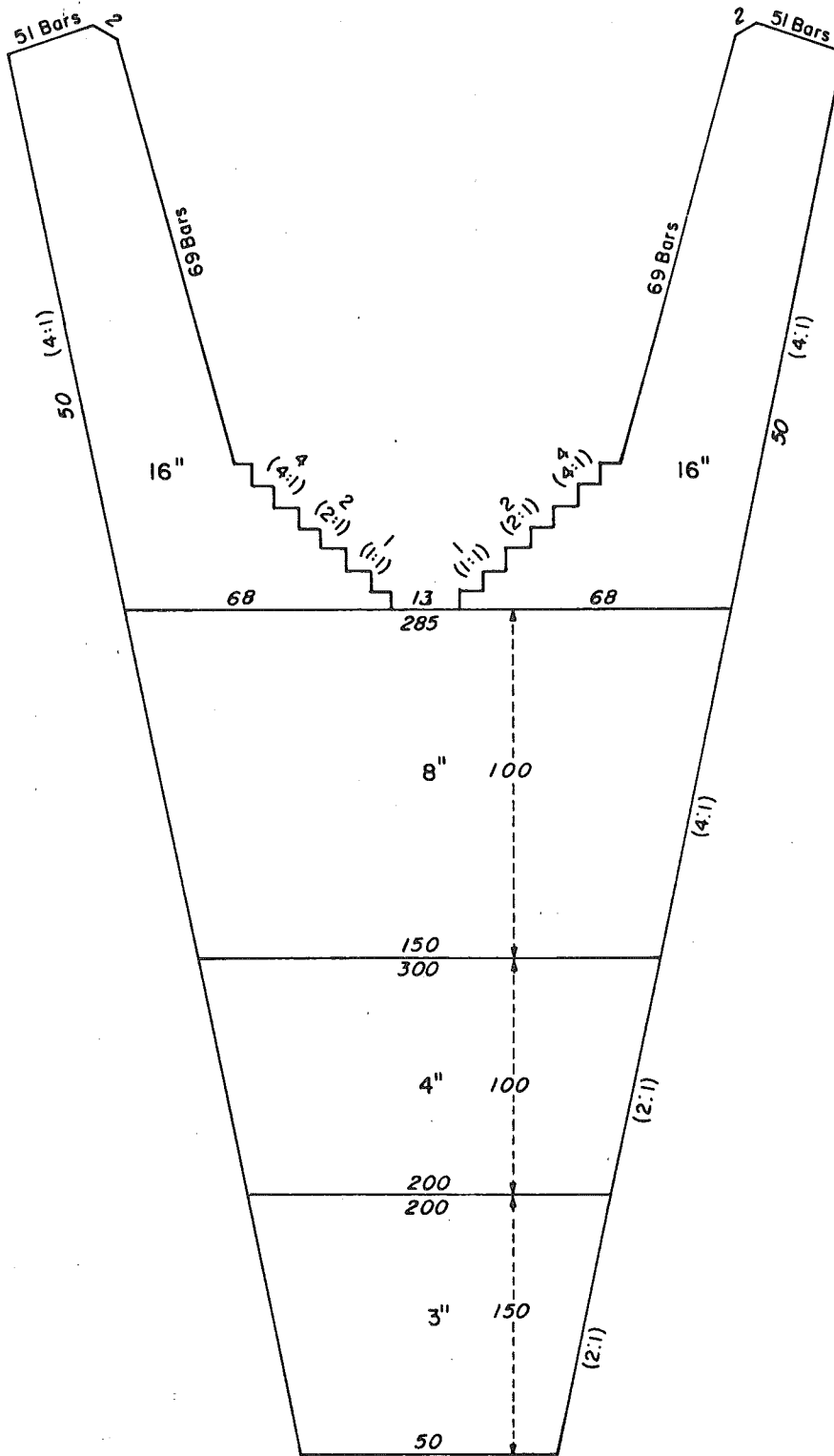

FIGURE 9  
CASH CORNER 8" HIGH RISE

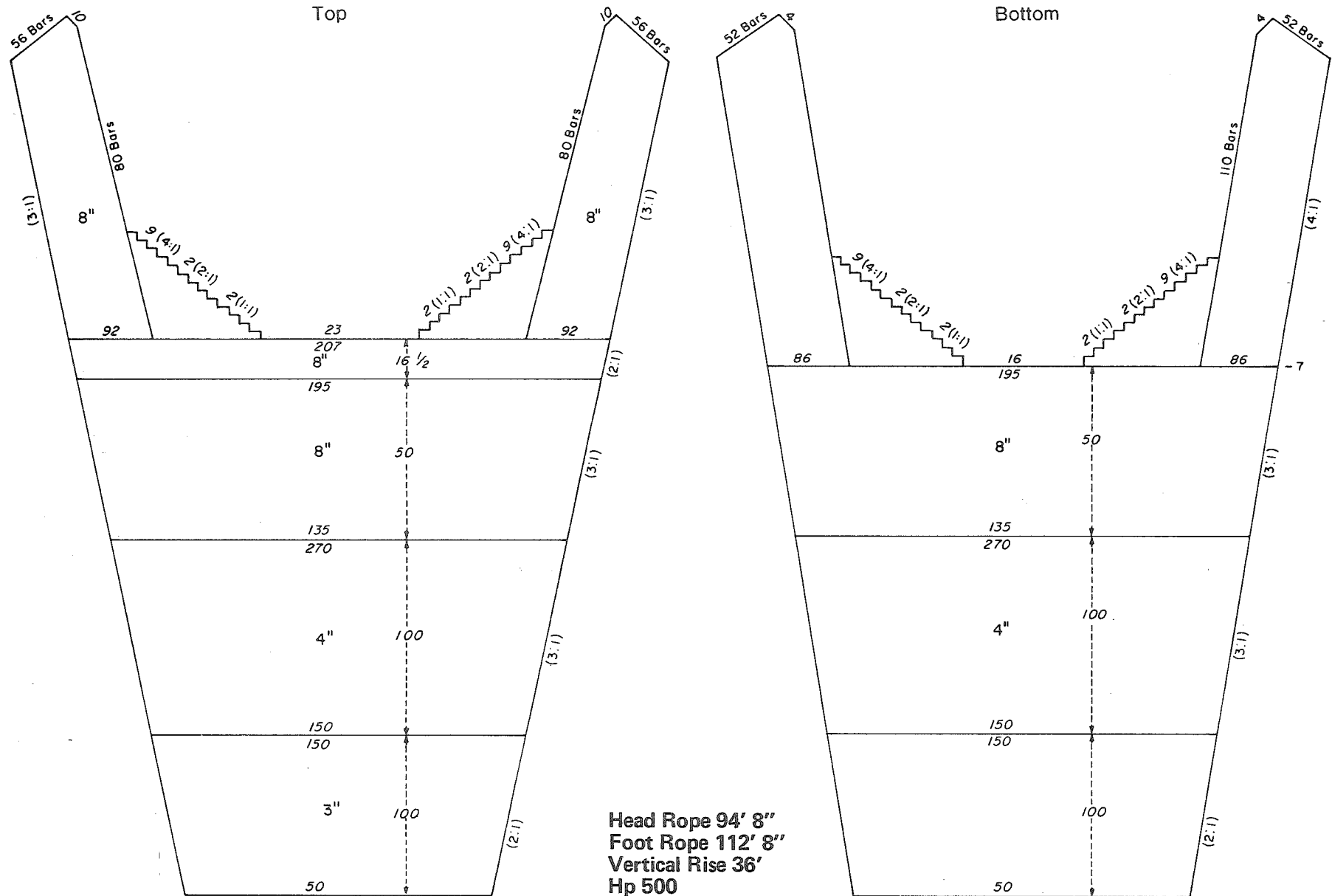
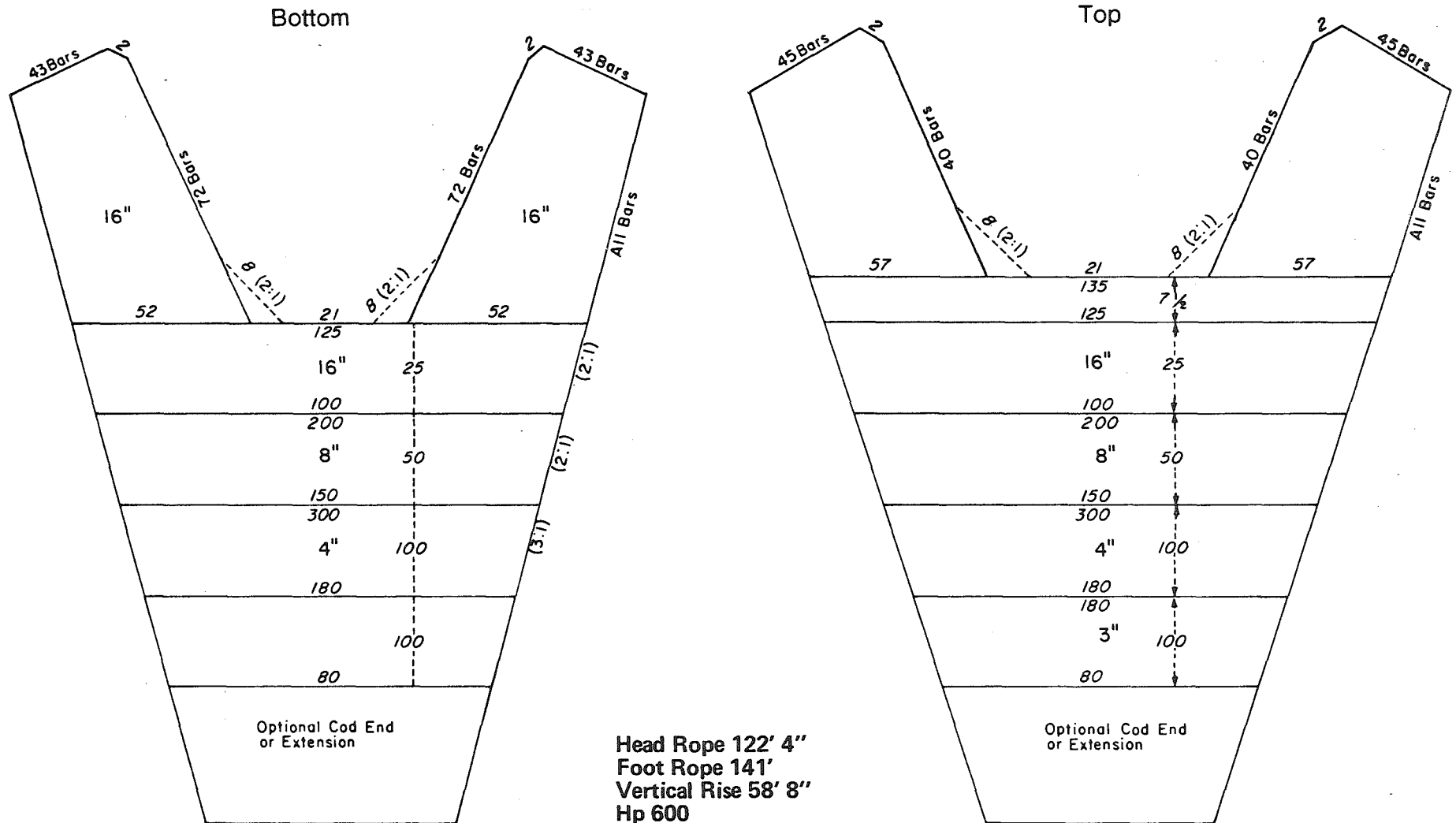

FIGURE 10  
CASH CORNER 16" HIGH RISE







The authors would like to extend their gratitude and appreciation to the following people and companies that made this publication possible: Gus and Albert Genovese of Cape May, N.J., Roger Harris of the Roger Harris Net Co., Atlantic, N.C., and Gib Sadler of the Cash Corner Net Co., Hobucken, N.C.

For further information about Squid Nets, please contact:

Philip Cahill and W. E. "Bill" Mansfield  
Commercial Fisheries Gear Specialists  
Virginia Sea Grant Marine Advisory Service  
Virginia Institute of Marine Science  
Gloucester Point, Virginia 23062  
(804) 642-7168

  <b>Marine Resource Advisory</b>
<b>NO. 27</b> <span style="float: right;"><b>September 1984</b></span>
Susan Schmidt. . . . . Editor
Marine Resource Advisories are produced by the Virginia Sea Grant College Program Marine Advisory Services at the Virginia Institute of Marine Science, School of Marine Science of the College of William and Mary. Single copies of this Advisory No. 27 are available free to Virginia citizens and at \$1.00 to others. Write the Publications Office, Virginia Sea Grant, VIMS, Gloucester Point, VA 23062.
Dr. Frank O. Perkins . . . . . Dean/Director Virginia Institute of Marine Science
Dr. William L. Rickards . . . . . Director Virginia Sea Grant College Program
Dr. William D. DuPaul . . . . . Director Marine Advisory Services

NON PROFIT ORGANIZATION
U. S. POSTAGE PAID
GLOUCESTER POINT, VA PERMIT NO. 6