

2013

Food Availability and Utilization for Cultured Hard Clams

Richard Garrik Secrist

College of William and Mary - Virginia Institute of Marine Science

Follow this and additional works at: <https://scholarworks.wm.edu/etd>



Part of the [Fresh Water Studies Commons](#), and the [Oceanography Commons](#)

Recommended Citation

Secrist, Richard Garrik, "Food Availability and Utilization for Cultured Hard Clams" (2013). *Dissertations, Theses, and Masters Projects*. Paper 1539617932.

<https://dx.doi.org/doi:10.25773/v5-hf2a-8d36>

This Thesis is brought to you for free and open access by the Theses, Dissertations, & Master Projects at W&M ScholarWorks. It has been accepted for inclusion in Dissertations, Theses, and Masters Projects by an authorized administrator of W&M ScholarWorks. For more information, please contact scholarworks@wm.edu.

Food Availability and Utilization for Cultured Hard Clams

A Thesis

Presented to

The Faculty of the School of Marine Science
The College of William and Mary in Virginia

In Partial Fulfillment

Of the Requirements for the Degree of
Master of Science

by

Richard Garrik Secrist

2013

APPROVAL SHEET

This thesis is submitted in partial fulfillment of

the requirements for the degree of

Master of Science

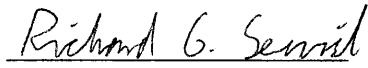
Richard G. Secrist

Approved, by the committee, April 2013

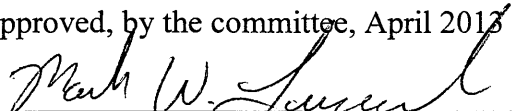
Mark W. Luckenbach, Ph.D.
Co-Advisor

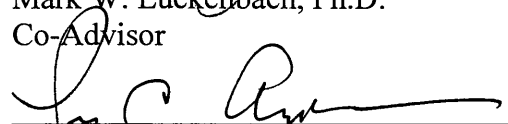
Iris C. Anderson, Ph.D.
Co-Advisor

Mark J. Brush, Ph.D.



Carl T. Friedrichs, Ph.D.

TABLE OF CONTENTS

	Page
ACKNOWLEDGEMENTS _____	v
LIST OF TABLES _____	vi
LIST OF FIGURES _____	vii
ABSTRACT _____	viii
INTRODUCTION _____	2
OBJECTIVES AND HYPOTHESES _____	6
BACKGROUND _____	7
<i>Hard Clam Aquaculture</i> _____	7
<i>Hard Clam Feeding</i> _____	9
<i>Food Sources</i> _____	11
<i>Factors Affecting Clam Feeding</i> _____	15
<i>Food Limitation</i> _____	16
<i>Modeling of Bivalve Aquaculture Systems</i> _____	18
<i>Research on Clam Aquaculture on the Eastern Shore of Virginia</i> _____	20
METHODS _____	24
I. Food Availability Study _____	24
<i>Study Site and Food Availability Sampling</i> _____	24
<i>Water Sample Collection and Analysis</i> _____	24
<i>Macroalgae and Benthic Samples</i> _____	27

II. Feeding Experiments _____	28
<i>Diet Preparation</i> _____	28
<i>Experimental Design</i> _____	29
<i>Feeding Measurements</i> _____	30
<i>Individual Food Source Experiments</i> _____	31
<i>Mixed Food Source Experiments</i> _____	32
<i>Statistical Analyses</i> _____	35
RESULTS _____	36
I. Food Availability Study _____	36
<i>Macroalgal Biomass</i> _____	36
<i>Water Column Samples</i> _____	38
<i>Comparisons of Food Availability Indicators</i> _____	42
<i>Benthic Samples</i> _____	49
II. Feeding Experiments _____	52
<i>Clearance Rates</i> _____	52
<i>Absorption Efficiency and Total Suspended Solids in Food Sources</i> _____	56
<i>Relative Food Value Indices</i> _____	56
DISCUSSION _____	59
I. Food Availability _____	59
II. Feeding Experiments _____	63
CONCLUSION _____	70
LITERATURE CITED _____	71
VITA _____	82

ACKNOWLEDGEMENTS

This project would not have been possible without the hard work of many people over the past three years, and I would like to thank them for their contributions. First, to my advisors Dr. Mark Luckenbach and Dr. Iris Anderson for all of their guidance, and my committee members Dr. Mark Brush and Dr. Carl Friedrichs for their interest and ideas. A big thanks goes out to the staff of the VIMS Eastern Shore Lab for their assistance and enthusiasm throughout my experiments: P.G. Ross, Alan Birch, and Edward Smith contributed many hours to my field studies and Stephanie Bonniwell and Paige Smith provided the resources and assistance I needed to conduct my feeding experiments. Thanks also to Jen Stanhope, Hunter Walker, Daniel Maxey, Meaghan Whitehead, and Annie Murphy of the Anderson lab for all their help learning lab techniques and processing samples.

The staff of other labs at VIMS contributed their expertise to help me learn new techniques: Lisa Ott taught me how to prepare and count epifluorescence samples, Marta Sanderson and Michele Cochran assisted me with the N15 analyses, and Erin Ferer helped to run many C:N samples. Many summer interns at VIMS also contributed to this project. Cherrystone Aqua-Farms provided the unique opportunity to conduct my research on a large-scale clam farm.

I would like to thank my friends Matt Freedman, Judy Gwartney-Green, and Sherry Rollins for their help in the field and the lab, and for all of their encouragement and support. Also, thanks to my fellow students who have been a part of my many experiences at VIMS. Finally, I would like to thank my parents, Richard and Spain Secrist, and my brother Keane for inspiring me to follow my dreams and for their constant encouragement over the years.

This project was supported by the VIMS Grey Allison and H. Renwick Dunlap Fellowship, Virginia Sea Grant, and the National Science Foundation's GK-12 "Partnership between Educators and Researchers for Enhancing Classroom Teaching" Fellowship (DGE-0840804).

LIST OF TABLES

Table	Page
1. Treatment solutions in individual food source experiments _____	33
2. Treatment solutions in the mixed food source experiment _____	34
3. Statistical comparisons of water sample parameters in field surveys _____	39
4. <i>Mercenaria mercenaria</i> clearance rate relationships from previous studies _____	65

LIST OF FIGURES

Figure	Page
1. Chesapeake Bay and location of Cherrystone Inlet _____	21
2. Primary production and clam carbon demand in Cherrystone Inlet _____	23
3. Placement of water sampling intakes (food availability field study) _____	26
4. Macroalgal dry weight on clam beds _____	37
5. Water column concentrations of centric and pennate diatoms _____	40
6. Water column sample parameters (chlorophyll, phaeophytin, and POM) _____	41
7. Regression for macroalgal biomass and particulate organic matter _____	43
8. Regression for macroalgal biomass and chlorophyll <i>a</i> (20 μm fraction) _____	44
9. Regression for macroalgal biomass and phaeophytin <i>a</i> (0.7 μm fraction) _____	45
10. Regression for macroalgal biomass and phaeophytin <i>a</i> (20 μm fraction) _____	46
11. Regression for macroalgal biomass and benthic chlorophyll <i>a</i> _____	47
12. Regression for macroalgal biomass and above - below net diatoms _____	48
13. Benthic chlorophyll <i>a</i> and phaeophytin <i>a</i> on clam beds and bare controls _____	50
14. Pennate-to-centric diatom ratios in sediment samples _____	51
15. Percent of clams feeding during clearance rate measurements _____	53
16. Mass-specific clearance rates for individual food treatments _____	54
17. Mass-specific clearance rates for mixed food treatments _____	55
18. Percent absorption efficiencies for food sources _____	57
19. Relative food value indices for food sources _____	58

ABSTRACT

Aquaculture of the hard clam *Mercenaria mercenaria* is a valuable industry on the east coast. At high planting densities, cultured bivalves can become limited by food availability, resulting in reduced growth. Centric diatoms are considered the dominant food source to cultured bivalves. Alternative sources may also be important, including resuspended benthic microalgae (pennate diatoms) and detritus from macroalgae growing on predator exclusion nets. This study measured (1) the availability of different food sources in clam beds at Cherrystone Inlet in Chesapeake Bay, including the effects of macroalgae on food availability, and (2) the clearance rates and absorption efficiencies by cultured clams on individual and mixed food treatments in laboratory feeding experiments. Abundances of benthic microalgae (pennate diatoms) were similar to or greater than centric diatoms. Detritus availability under nets was related significantly to macroalgal abundance. Mass-specific clearance rates and absorption efficiencies were similar among food sources, but differences in the percentage of clams feeding on each treatment suggest macroalgal detritus was less utilized by clams than either phytoplankton or benthic microalgae. Both phytoplankton and benthic microalgae appeared to be valuable food sources to clams, both in terms of *in situ* abundance and relative food value indices calculated from feeding studies. Though food value was lower for macroalgal detritus, the high availability of this source to clams during blooms suggests it may be important seasonally. Lower diatom concentrations under nets compared to above during a macroalgal bloom suggest dense blooms may limit diatom availability to clams. Future modeling of cultured bivalve carrying capacity should consider the importance of multiple food sources in aquaculture environments.

Food Availability and Utilization for Cultured Hard Clams

INTRODUCTION

Bivalve aquaculture is a rapidly growing and economically important method of food production worldwide. Harvests of cultured mollusks, primarily bivalves, represent about 24% of global aquaculture by weight, and clams and cockles are the fastest-growing and most produced group (FAO, 2012). Most cultured bivalves are suspension feeders, filtering seston from the water column including phytoplankton and resuspended benthic microalgae (Bayne and Hawkins, 1992; Wildish and Kristmanson, 1997; Riera et al., 1999; Yokoyama et al., 2009). At high densities, cultured bivalves can exhibit top-down control on phytoplankton (Muschenheim and Newell, 1992; Huang et al., 2008). If the filtration pressure by bivalves is sufficiently high, food limitation and reduced growth can occur on scales ranging from 1-2 m² (Peterson, 1982; Summerson et al., 1995), across tidal flats (Peterson and Black, 1987), and in entire embayments (Carver and Mallet, 1990; Smaal et al., 2001). Fréchette and Bourget (1975) observed that particulate organic matter can be depleted above mussel beds at small scales. Food limitation may cause growth rates to be reduced in bivalves higher in tidal flats, as individuals lower in the flat deplete the incoming tide of food (Peterson and Black, 1987). The degree of food limitation can also vary seasonally. Clam metabolic demand increases with temperature, and if such increases occur prior to phytoplankton blooms, demand may exceed food availability (Zarnoch and Schreiber, 2008).

Culture of the northern hard clam (*Mercenaria mercenaria*), an infaunal suspension feeder, is the most valuable shellfish aquaculture industry on the east coast of the United States, generating over \$50 million per year (SRAC, 2005). Typically, cultured *M.*

mercenaria are spawned in hatcheries, then moved either as pre-settled larvae or after settlement to separate nurseries, where they are usually fed natural phytoplankton from seawater for 4 to 12 months. After reaching a size of 9-15 mm, clams are planted in shallow grow-out sites such as tidal creeks (Kraeuter and Castagna, 1977; Castagna, 1984; Castagna, 2001). Clams are typically planted at densities of 550 to 1650 clams/m² (Luckenbach and Wang, 2004) and covered with plastic-mesh predator exclusion nets (Castagna, 1984; Grabowski et al., 2000; Castagna, 2001). Clams are harvested after a sufficient percentage (about 70%) reaches a market size of about 50 mm shell height (Castagna, 2001). Although clams are planted at high densities to increase yields, food limitation can occur in aquaculture settings if density is sufficiently high, leading to reduced clam growth (Summerson et al., 1995; Luckenbach and Wang, 2004).

While phytoplankton are a major food source for *M. mercenaria*, the quality of the food is dependent on taxa. Centric diatoms have been shown to be a high-quality food source, while dinoflagellates have been associated with relatively lower absorption efficiencies and growth rates (Walne, 1970; Greenfield et al., 2004; Greenfield et al., 2005; Weiss et al., 2007). Resuspended benthic microalgae (BMA) may serve as an abundant alternative to phytoplankton as a food source (de Jonge and Beusekom, 1995; Yokoyama et al., 2009). Compared to centric diatoms, lower absorption efficiencies and growth rates in *M. mercenaria* have been observed for BMA (Wikfors et al., 1992; Greenfield et al., 2004; Greenfield et al., 2005). However, these organisms can be highly abundant in the water column when resuspended (de Jonge and Beusekom, 1992; Muschenheim and Newell, 1992), such that the relative importance of phytoplankton and BMA may vary depending on local conditions (Yokoyama et al., 2009). Furthermore, studies using stable isotope mixing models suggest that BMA are a significant food source to suspension feeding bivalves

(Kanaya et al., 2007; Yokoyama et al., 2009). In a study of food filtration and assimilation, Kreeger and Newell (2001) showed that the mussel *Geukensia demissa* preferred BMA over phytoplankton. BMA have been suggested as an important food source for mussels and oysters when pelagic primary production is insufficient to meet grazing pressure (Muschenheim and Newell, 1992; Smaal and Zurburg, 1997) and during seasons when phytoplankton are scarce (de Jonge and Beusekom, 1995).

Food availability may also be affected by macroalgal growth, as dense blooms can occur on predator exclusion nets in hard clam aquaculture settings (Powers et al., 2007). Blooms typically occur in late spring and early summer and die off in July and August due to increasing temperatures and self-shading (McGlathery et al., 1997; Higgins et al., 2008). Detritus from macroalgal breakdown may be available as a food source for clams. Stable isotope mixing model studies have measured variable contributions of macroalgae to bivalve diets. Macroalgae were the primary diet (85%) in one study of the clam *Austrovenus stutchburyi* (Leduc et al., 2006), but were a minor contributor (13%) in a study on the diet of the oyster *Crassostrea gigas* (Schaal et al., 2008). However, macroalgal detritus may be an important seasonal food source for cultured clams given the potential for dense blooms in aquaculture settings. Macroalgal blooms may also affect the availability of other food sources. Currents and wave energy have been observed to reduce food depletion above mussel beds (Fréchette and Bourget, 1975), but macrophytes can act as a barrier to water flow (Judge et al., 2003) and reduce mixing. Similarly, dense macroalgal growth on clam aquaculture nets may reduce resuspension, mixing, and potentially food availability to cultured clams.

Studies have emphasized the importance of phytoplankton in supporting bivalve survival and growth (Heip et al. 1995; Grant et al. 1998; Zarnoch and Schreiber, 2008), including the use of modeling to predict the carrying capacity of bivalves (Smaal et al., 2001). Chlorophyll *a* has been used as a proxy for food availability in models of bivalve growth (Hofmann et al., 2006) and carrying capacity (Smaal et al., 2001). Other modeling studies have compared chlorophyll *a* to lipid, protein, and labile carbohydrate concentrations as indicators of food availability and suggest that chlorophyll *a* can underestimate growth (Soniati et al., 1998; Hyun et al., 2001). Alternatively, particulate organic matter may be used as an indicator of food availability for cultured bivalves (Carver and Mallet, 1990; Ferreira et al., 1998). Other studies have included both phytoplankton and detritus terms in models of bivalve growth and carrying capacity (Dowd, 1997; Bacher et al., 1998; Scholten and Small, 1998). Understanding the roles of different food sources may be important in predicting the carrying capacity of aquaculture systems, as these food sources may vary in availability and value to cultured bivalves.

This study aimed to investigate the importance of different food sources to cultured *M. mercenaria*, including phytoplankton, benthic microalgae, and macroalgal detritus. The first component of this research evaluated the availability of each food source to clams in an aquaculture setting, including the influence of macroalgal blooms on these availabilities. Secondly, the utilization of each source by clams was measured in laboratory feeding experiments to calculate both food filtration (clearance rate) and absorption.

OBJECTIVES AND HYPOTHESES

This research investigated the availability of phytoplankton and alternative food sources to *Mercenaria mercenaria* in a clam farm in Cherrystone Inlet, including the effects of macroalgal growth on aquaculture nets. Furthermore, the utilization of these food sources was measured for cultured clams. The project had two main objectives:

- (1) Characterize the availability of phytoplankton and alternative food sources to cultured clams in Cherrystone Inlet under predator exclusion nets, above nets, and in surrounding areas; and
- (2) Evaluate the value of these food sources for cultured clams in the laboratory

The following hypotheses were tested.

- Diatoms will become depleted under aquaculture nets in water just above the sediment-water interface compared to above nets during warmer months when clam metabolic rates and macroalgal abundances are high.
- Chlorophyll *a* and phaeophytin *a* concentrations in suspended matter under nets will be positively correlated with macroalgal biomass on nets.
- Food concentration outside of aquaculture nets will be higher at ebb and flood tides than at slack tides, but will not be affected by tides under nets.
- Centric diatoms will have a higher food value (determined from clearance rate and absorption efficiency) for cultured clams than pennate diatoms, and macroalgal detritus will have a lower food value compared to diatoms.

BACKGROUND

Aquaculture is currently the fastest-growing method of animal food production worldwide, providing nearly half of total seafood production. Harvests of mollusks, primarily bivalves, represent about 24% of global aquaculture, and clams and cockles are the fastest-growing and most produced group (FAO, 2012). The northern hard clam *Mercenaria mercenaria*, an infaunal suspension feeder, is a major aquaculture species in the United States. The hard clam's natural range extends from Canada to Florida, where it is found in both intertidal and subtidal sediments (Harte, 2001). It is cultured throughout the east coast (SRAC, 2005), as well as western Florida (Adams et al., 2009). Hard clam aquaculture is the most valuable shellfish aquaculture industry on the east coast, generating over \$50 million per year (SRAC, 2005). Virginia currently leads the nation in clam aquaculture. In 2011, 182 million clams were sold in Virginia, at an approximate total value of \$29 million dollars (Murray and Hudson, 2012). Most cultured shellfish are suspension feeders, filtering seston from the water column including phytoplankton and resuspended benthic algae (Bayne and Hawkins, 1992; Wildish and Kristmanson, 1997; Yokoyama et al., 2009). One concern with aquaculture operations is that shellfish planted at high densities will deplete the food supplies of cultured organisms, resulting in limited growth.

Hard Clam Aquaculture

Modern aquaculture of *M. mercenaria* commonly consists of three stages: hatchery, nursery, and grow-out. First, clam larvae are spawned in hatcheries, then moved either as

pre-settled larvae or after settlement to separate nurseries, where they will spend 4 to 12 months. At sufficiently high temperatures (above 12-15°C), natural phytoplankton from seawater is usually sufficient to feed juveniles, although they may require supplements of cultured algae if clams are kept in static tanks or if temperatures of pumped seawater are low (Castagna, 1984). Juveniles are grown to a size of 9-15 mm, as smaller individuals in the field are vulnerable to predators such as crabs even when protected by mesh nets (Kraeuter and Castagna, 1977; Castagna, 1984; Castagna, 2001). Finally, clams are moved to a grow-out site in shallow water and harvested after a sufficient percentage of clams (usually about 70%) reaches a market size of about 50 mm shell height, though commercial sizes are typically measured using shell width (Castagna, 2001). Attempts to grow clams to market size in tanks or other controlled setups have been unsuccessful due to the high costs of pumping seawater or of providing supplemental phytoplankton for their dietary needs, which increase geometrically with size. The most common method for growing clams involves planting juveniles in beds on a natural shallow bottom and covering them with a plastic mesh net to exclude predators (Castagna, 1984; Grabowski et al., 2000; Castagna, 2001). Other predator exclusion methods include gravel coverings and mesh bags. These methods may result in lower clam growth rates (Summerson et al., 1995; Grabowski et al., 2000), although in the case of mesh bags Grabowski et al. documented higher survival rates relative to mesh netting. The hard clam industry has grown rapidly in Virginia, where clams are grown out in shallow tidal creeks flowing into the Chesapeake Bay and in coastal embayments behind barrier islands (Luckenbach and Wang, 2004).

Hard Clam Feeding

Filter-feeding bivalves like *M. mercenaria* filter particulate matter from the water column using their gills. Hard clams have two gills, each composed of two half-gills or demibranchs, which are in turn composed of two flat filamentous structures called “lamellae” joined in a V-shape (Eble, 2001). In lamellibranch bivalves, these lamellae are comprised of cirri which branch off into cilia (Moore, 1971). The hard clam’s gills produce currents through ciliary movement, pumping water in and out of the organism through inhalant and exhalant siphons. Water is brought into contact with the gills, and particles that are retained by the gill cirri are accumulated in gill tracts between plates, along which they are passed to the labial palps (Ward et al., 1993; Grizzle et al., 2001). Filtered particles are mainly sorted prior to ingestion on the palps. Non-ingested particles are expelled through the inhalant siphon as pseudofeces. The remaining particles are moved to the mouth and ingested, after which they will either be absorbed by the animal or egested as feces (Grizzle et al., 2001). Through several mechanisms, bivalves can differentiate between algal species even when they are of similar size, and depending on the species of bivalve the selection of food can occur during filtering (mechanical sieving by gills), before ingestion (sorting on the labial palps and expulsion of matter as pseudofeces), or after ingestion through differential gut absorption (Shumway et al., 1985).

The size of suspended particles is an important factor in a bivalve’s ability to efficiently filter, retain, and ingest food. In *M. mercenaria*, filtered particles above 4 μm are fully retained by the gill cirri (Riisgård, 1988), and Weiss et al. (2007) correlated concentrations of phytoplankton larger than 5 μm with increased juvenile growth rates. Retention efficiency for particles below 4 μm steadily decreases, with about half of 2 μm

particles being retained (Riisgård, 1988). Thus, smaller potential food sources like bacteria are filtered with very low retention efficiencies (Langdon and Newell, 1990). Furthermore, smaller food sources, even when retained, are not absorbed efficiently by clams. Bass et al. (1990) found that while *M. mercenaria* can filter cyanobacteria and picoplankton (the chlorophyte *Nannochloris atomus*, about 3 µm in diameter), their absorption efficiency for these organisms is only 17-31%, compared to 86.5% for *Pseudoisochrysis paradoxa*, which is approximately 5-6 µm in diameter (Turner et al., 1988). Furthermore, clams fed *N. atomus* did not show significant growth in a six-week experiment (Bass et al., 1990).

The maximum size of particles that *M. mercenaria* can efficiently retain is uncertain (Grizzle et al., 2001). Experiments on the infaunal bivalve *Cerastoderma edule* showed that it can retain particles up to 500 µm, and that clearance rates for particles 60-300 µm were similar to rates for 4 µm particles. This suggests that larger detrital particles have the potential to serve as a food source for bivalves (Karlsson et al., 2003).

After filtering and retention, the sorting of particles between expulsion as pseudofeces and ingestion allows filter-feeding bivalves to selectively consume higher-quality organic particles, expelling lower-quality and inorganic matter as pseudofeces (Bacon et al., 1998; Grizzle et al., 2001). Pseudofeces production is negligible in *M. mercenaria* below certain concentrations of particulates. Bricelj and Malouf (1984) conducted experiments on *M. mercenaria* fed mixtures of *Pseudoisochrysis paradoxa* and freeze-dried surface sediment collected from a subtidal site. Pseudofeces production was nonexistent or very low under suspended sediment concentrations of 10 mg/L. At high suspended sediment concentrations, however, selective rejection of particles as pseudofeces allowed hard clams to ingest mainly suspended algae while minimizing consumption of sediment. With the rejection of silt (at

ambient silt concentrations up to 40 mg/L), *M. mercenaria* lost up to 18% of filtered algae in pseudofeces. However, increasing suspended sediment concentrations does result in a decrease in ingested algae by *M. mercenaria*, due to reduced feeding rates and loss of algae in pseudofeces (Bricelj and Malouf, 1984). While some other bivalves, such as the mussel *Mytilus edulis* and the oyster *Crassostrea virginica*, respond to high turbidity with increased pseudofeces production (Kjørboe et al., 1980; Haven and Morales-Alamo, 1966), the primary response of *M. mercenaria* is to reduce feeding rate. Thus, hard clams are likely to be less adapted than either mussels or oysters to high suspended sediment concentrations (Bricelj and Malouf, 1984).

Food Sources

The diet of filter-feeding bivalves is comprised mainly of suspended particulate matter including phytoplankton, resuspended benthic microalgae, detritus, and bacteria (Bayne and Hawkins, 1992; Yokoyama et al., 2009), although bacteria are filtered with very low retention efficiencies (Langdon and Newell, 1990). Although not a major food source, *M. mercenaria* is also capable of deriving some nutrition from dissolved organic matter, through the uptake of free amino acids (Rice and Stephens, 1988). Hard clam growth is affected by the species composition of its diet. Walne (1970) compared growth rates of *M. mercenaria* fed 19 different unialgal diets and observed a variety of growth rates dependent on algal species. Wikfors et al. (1992) also compared unialgal diets and observed a positive correlation between protein and lipid contents of diets and growth rate in *M. mercenaria*.

Centric diatoms are a high-quality food source for *M. mercenaria*. Laboratory feeding studies have associated high hard clam growth rates with centric species such as

Skeletonema costatum (Walne, 1970) and *Thalassiosira pseudonana*, for which clams had a high absorption efficiency (Greenfield et al., 2004). In two bays with similar temperatures and salinities but different phytoplankton compositions, Greenfield et al. (2005) found higher *in situ* clam growth in the bay dominated by centric diatoms compared to the bay dominated by pennate diatoms and dinoflagellates, and suggested that centric diatoms are more nutritious and support higher growth rates than either pennate diatoms or dinoflagellates. In laboratory studies of hard clams, the dinoflagellate *Prorocentrum minimum* was associated with relatively lower absorption efficiencies (Greenfield et al., 2004). Weiss et al. (2007) found a negative correlation between abundances of larger dinoflagellates (> 10µm) and clam growth *in situ*, and noted that harmful algae species were present and may partially account for this negative relationship.

During periods of phytoplankton limitation, alternative food sources may play an important role in sustaining cultured clams. One alternative food source is benthic microalgae that are resuspended into the water column mainly by tidal currents and wind-driven waves (de Jonge and Beusekom, 1995; Yokoyama et al., 2009). In some areas, resuspended benthic microalgae (primarily benthic diatoms) can account for up to 50% of water column chlorophyll (de Jonge and Beusekom, 1992). Benthic diatoms tend to be pennate in shape (Fryxell, 1983; Smyth, 1995, Marshall, 2009), a morphology that may reduce the filtering efficiency of these organisms by bivalves (Greenfield et al., 2005). Laboratory feeding studies of the pennate diatom *Nitzschia closterium* associated it with relatively low growth rates (Wikfors et al., 1992) and absorption efficiencies (Greenfield et al., 2004). However, they are potentially important as an alternative food source to grazers during seasons when phytoplankton are scarce (de Jonge and Beusekom, 1992).

Muschenheim and Newell (1992) observed relatively high concentrations of pennate benthic diatoms (including *Nitzschia*, *Pleurosigma*, and *Gyrosigma* species) in the water column upstream of beds of the mussel *Mytilus edulis* compared to over beds, and suggested that they constituted a major part these organisms' diet. In experiments using *in situ* benthic tunnels in the Marennes-Oléron Bay, Smaal and Zurburg (1997) determined that pelagic primary production in the bay was insufficient to meet the filtration pressure of oysters and mussels, and suggested that the resuspension of benthic diatoms was an important alternative food source.

Detritus from plants and macroalgae are another potential food source for bivalves. While high-cellulose detritus (mainly from *Spartina alterniflora*) was not shown to be a usable food source in studies of the mussel *Geukinsia demissa* and the oyster *Crassostrea virginica* (Langdon and Newell, 1990), macroalgae may be more digestible than high-cellulose material. Findlay and Tenore (1982) used isotope enrichment studies of feeding by the polychaete *Capitella capitata* to determine whether organisms derived more nitrogen from feeding directly on detrital material or the bacterial detritivores associated with that material. Their results suggest that polychaetes fed the macroalgae *Gracilaria foliifera* derive more nitrogen from the macroalgae itself, while polychaetes fed *S. alterniflora* derive most nitrogen from associated microbes. Furthermore, stable isotope studies of the gastropod *Hydrobia ulvae* suggest it can directly consume detritus from stranded macroalgae of the genus *Enteromorpha* (Riera, 2010). Given the low filtration efficiency of bacteria by bivalves (Langdon and Newell, 1990), the ability of invertebrates to directly consume macroalgal detritus suggests that it may be a more usable food source for bivalves than plant

detritus. In one study using stable isotope mixing models, macroalgae was found to be the primary diet (85%) of the clam *Austrovenus stutchburyi* (Leduc et al., 2006).

However, some studies suggest that macroalgal detritus may not be a high quality food source for bivalves. A stable isotope study on the diet of the oyster *Crassostrea gigas* (Schaal et al., 2008) showed macroalgae to be a minor contributor (13%). In a study on the deposit-feeding clam *Abra ovate*, Charles (1993) observed that absorption efficiencies were low for clams fed two species of macroalgal detritus (*Cystoseira mediterranea*, 8.6%; and *Posidonia oceanica*, 2.5%) ground to less than 200 μm , although ingestion rate was correlated with detrital concentration. Several studies on kelp detritus suggest that bivalves' ability to utilize detritus increases as detritus ages. Degradation of detritus decreases its content of polyphenolic compounds, which have been associated with lower clearance rates and growth in bivalves fed kelp detritus (Duggins and Eckman, 1997; Levinton et al., 2002). Cranford and Grant (1990) found that kelp powder aged in seawater for 5 days was assimilated significantly more efficiently by scallops (*Placopecten magellanicus*) compared to fresh kelp powder, and that this aged detritus was assimilated more efficiently than phytoplankton. However, due to the low quantities of detritus ingested and its lower nitrogen content, the detritus did not contribute to growth.

Macroalgae with higher nitrogen content may be more valuable to bivalves. Algae grown in eutrophic areas often have higher tissue nitrogen content (Valiela et al., 1997). Further research into the role of macroalgae as a food source is particularly important, as macroalgal proliferation has increased due to anthropogenic coastal eutrophication (Valiela et al., 1997; Morand and Merceron, 2005; Lapointe and Bedford, 2007). This is especially

relevant in hard clam aquaculture settings, where abundant macroalgal growth can occur on predator exclusion nets (Powers et al., 2007).

While macroalgal growth on nets may provide a food source to clams as it breaks down, it may also have negative impacts on clam feeding. During dense blooms, the photosynthesis and respiration of large concentrations of macroalgae during the day and night, respectively, may significantly impact daily oxygen cycles (Valiela et al., 1992). Thus, macroalgae may affect clam growth by contributing to alternately high and low oxygen levels. Furthermore, the decomposition of excessive blooms of macroalgae may cause anoxia and clam mortality. In model simulations of the Sacca di Goro, Italy, Marinov et al. (2007) predicted that risks of anoxia and cultured clam mortality would increase with *Ulva* biomass. Macroalgal growth may also restrict the resuspension and mixing of other food sources under clam beds, potentially limiting food availability. Fréchette and Bourget (1975) observed that currents and wave energy can reduce food depletion over mussel beds, but macrophytes may limit water flow (Judge et al., 1993) and potentially negate this effect.

Factors Affecting Clam Feeding

Hard clam feeding rates are dependent on body size (Grizzle et al., 2001) and are influenced by a variety of environmental factors. *M. mercenaria* will feed at temperatures between 6° and 32°C (Hamwi, 1969). This relates to the amount of time clams open their valves. Studies of shell movement by Loosanoff (1939) showed that the percent of time *M. mercenaria* are open peaks between 21-22°C, while below 3°C their valves remain closed. *M. mercenaria* can survive at salinities as low as 12.5 (Castagna and Chanley, 1973), and can feed up to a salinity of about 35 (Hamwi, 1969). Hard clams are also affected by dissolved

oxygen concentrations. Hamwi (1969) correlated *M. mercenaria* pumping rates with oxygen concentrations at levels between 1 and 5 mg O₂ per liter and showed that feeding is reduced below oxygen levels of 5 mg/L. *M. mercenaria* growth is also inhibited at very high oxygen concentrations (about 115% saturation), as water supersaturated by air can cause “gas-bubble disease” in which bubbles of gas become trapped in the gills, inhibiting blood circulation (Malouf et al., 1972; Bisker and Castagna, 1985).

As described previously, feeding decreases with increasing suspended sediment concentrations, due to both reduced clearance rates and loss of algae in pseudofeces (Bricelj and Malouf, 1984). *M. mercenaria* also alter their feeding rate in response to actual food concentrations (Grizzle et al., 2001). Studies of clam growth rates by Walne (1970) showed that when fed the picoplankton algae *Micromonas pusilla*, clam growth peaked at an algal concentration of 500 cells/μL, but decreased at both higher (up to 2000 cells/μL) and lower (down to 50 cells/μL) concentrations. Feeding rates appear to peak at lower concentrations for larger algal cells, as Bricelj (1984) observed a decrease in *M. mercenaria* clearance rates on *Pseudoisochrysis paradoxa* as cell concentrations increased from 20 to 150 cells/μL. Tenore and Dunstan (1973) found that *M. mercenaria* feeding rate peaked at a food concentration of about 650 μg C/L when fed a diet of mixed algae dominated by *Skeletonema costatum*.

Food Limitation

In environments where the population density of filter-feeding bivalves is high, such as aquaculture settings, the bivalves can exhibit top-down control on food organisms. Muschenheim and Newell (1992) compared diatom concentrations upstream and downstream

of beds of the mussel *Mytilus edulis* and found significantly lower concentrations downstream, especially near the bottom. Huang et al. (2008) demonstrated a 5-fold increase in phytoplankton chlorophyll *a* and gross primary production in poorly-flushed areas of a lagoon after the removal of cultured oysters. If the filtration pressure of bivalves is sufficiently high, food limitation in the environment and decreased bivalve growth rates can result. In field manipulations of wild clams (*Protothaca staminea* and *Chione undatella*), Peterson (1982) observed reduced growth and reproductive effort due to high intraspecific densities at small scales (1 m²) and attributed this to food rather than space limitation. Peterson and Black (1987) suggested that reduced growth results from food depletion over larger scales in tidal flats, as organisms lower in the flat will deplete the incoming tide of food before it reaches organisms higher on the flat. In field grow-out trials of cultured *M. mercenaria*, Summerson et al. (1995) associated high planting densities with reduced growth due to food limitation.

The degree of food limitation can vary seasonally, as clam metabolic demand increases with temperature. In springtime, an increase in clam metabolic demand may exceed food availability if it occurs prior to phytoplankton blooms (Zarnoch and Schreibman, 2008). This problem may be exacerbated by low winter temperatures, which would reduce the amount of feeding by clams and require them to use stored energy before spring. Field observations of cultured *M. mercenaria* by Zarnoch and Schreibman (2008) show that while neither a severe winter nor low spring chlorophyll *a* resulted in high clam mortality independently, a year with both a severe winter and low spring chlorophyll *a* coincided with a high clam mortality rate (up to 0.99% per day).

Although phytoplankton availability is often considered a primary limiting factor for bivalve growth, alternative food sources may also be important in determining carrying capacity. As discussed above, resuspension can affect food availability for cultured bivalves by mixing benthic microalgae into the water column, making them available for filtration (de Jonge and Beusekom, 1992; de Jonge and Beusekom, 1995). Fréchette and Bourget (1975) correlated phaeopigment concentrations in beds of cultured *M. edulis* with wind-driven wave action and suggested that pseudofeces from mussels, including filtered phytoplankton, were also resuspended into the water column and would be available for re-filtering. Fréchette and Bourget (1975) also noted that particulate organic matter could become limited directly above mussel beds, and that currents and wave energy reduced this depletion effect, indicating the importance of these physical forces in aquaculture settings. Judge et al. (2003) suggest that macrophytes can act as a barrier to water flow, limiting mixing, resuspension, and potentially food availability (Fréchette and Bourget, 1975; Condon, 2005).

Modeling of Bivalves and Aquaculture Systems

A variety of studies have used modeling to investigate questions about aquaculture systems, including the growth of cultured bivalves (Dowd, 1997) and exploitation carrying capacity (Smaal et al., 1998). Many of these models have focused on phytoplankton as the food source controlling carrying capacity. Smaal et al. (2001) evaluated carrying capacity for mussels in the Oosterschelde estuary (Netherlands), based on pelagic primary production and chlorophyll *a* levels. Hoffman et al. (2006) modeled growth of *M. mercenaria* in response to temperature, salinity, total suspended solids, and food availability, with the latter being based on chlorophyll *a* levels modified by a term for non-algal food sources (described

below). Wiseman (2010) modified this model for use in the New River Estuary, NC and used chlorophyll *a* as a surrogate measure for food availability. This model showed increasing *M. mercenaria* growth with increasing chlorophyll *a* levels, and decreasing growth with increased total suspended solids. According to the model, clams consumed the highest percentages of total available food during mid-April and mid-October (Wiseman, 2010), suggesting that during these periods the potential for food limitation is highest.

Some studies have suggested that chlorophyll *a* alone is an inadequate indicator of food availability when modeling bivalve growth. Soniat et al. (1998) used measurements of total lipid, protein, and labile carbohydrate concentrations to account for non-algal food sources for the oyster *Crassostrea virginica* in Galveston Bay, Texas, and to calculate a regression between chlorophyll *a* and these concentrations. Modeling by Hyun et al. (2001) for Kamakman Bay in Korea found that models underestimated growth rates of the oyster *Crassostrea gigas* when using chlorophyll *a* as the measure of food availability. Growth rates were overestimated in this model when particulate lipid, protein, and labile carbohydrate concentrations were used. This was attributed to the fact that many food particles were small and not as accessible to oysters due to low retention (or possibly assimilation) efficiencies. These models suggest that chlorophyll *a* alone is insufficient when modeling oyster growth.

Other models have also included components for food availability other than phytoplankton. Ferreira et al. (1998) modeled cultured oyster carrying capacity in Carlingford Lough, Ireland, and found that capacity was dependent more on total (organic and inorganic) particulate matter availability than phytoplankton availability. Carver and Mallet (1990) modeled cultured mussel carrying capacity in Nova Scotia, Canada, using

particulate organic matter as a measure of food availability. However, modeling based on a single measure of food availability such as pelagic primary production, chlorophyll *a*, or particulate organic matter may not account for the relative importance of different alternative food sources, such as benthic microalgae and macroalgal detritus, which may be filtered or assimilated differently. In addition to phytoplankton, Dowd (1997) also included a non-phytoplankton seston component in a model to predict cultured mussel growth. This seston component included bacteria and macrophyte detritus as a food source for mussels. Phytoplankton and detritus have also been modeled together as food sources for mussels by Scholten and Smaal (1998) and for oysters by Bacher et al. (1998).

Research on Clam Aquaculture on the Eastern Shore of Virginia

Hard clam aquaculture has become a major industry on the Eastern Shore of Virginia, where it employs hundreds of watermen and supports the local economy (Murray and Kirkley, 2005). Cherrystone Inlet, a tidal embayment along the southeastern shoreline of the Chesapeake Bay (Figure 1), includes 37 aquaculture lease areas containing approximately 100 million clams (Condon, 2005). Growers in this inlet have reported lower growth rates of cultured clams in some farms (Luckenbach and Wang, 2004; Condon, 2005). Luckenbach and Wang (2004) suggested that phytoplankton abundance in Cherrystone Inlet may be limited by grazing pressure of cultured clams, and modeling of the system by Condon (2005) provides estimates that clam carbon demand can reach as high as 90% of net primary production in this system (estimated from near-shore, water-column gross primary production measurements in Cherrystone by Reay et al., 1995) during certain seasons,

Figure 1. Southern Chesapeake Bay and location of Cherrystone Inlet.

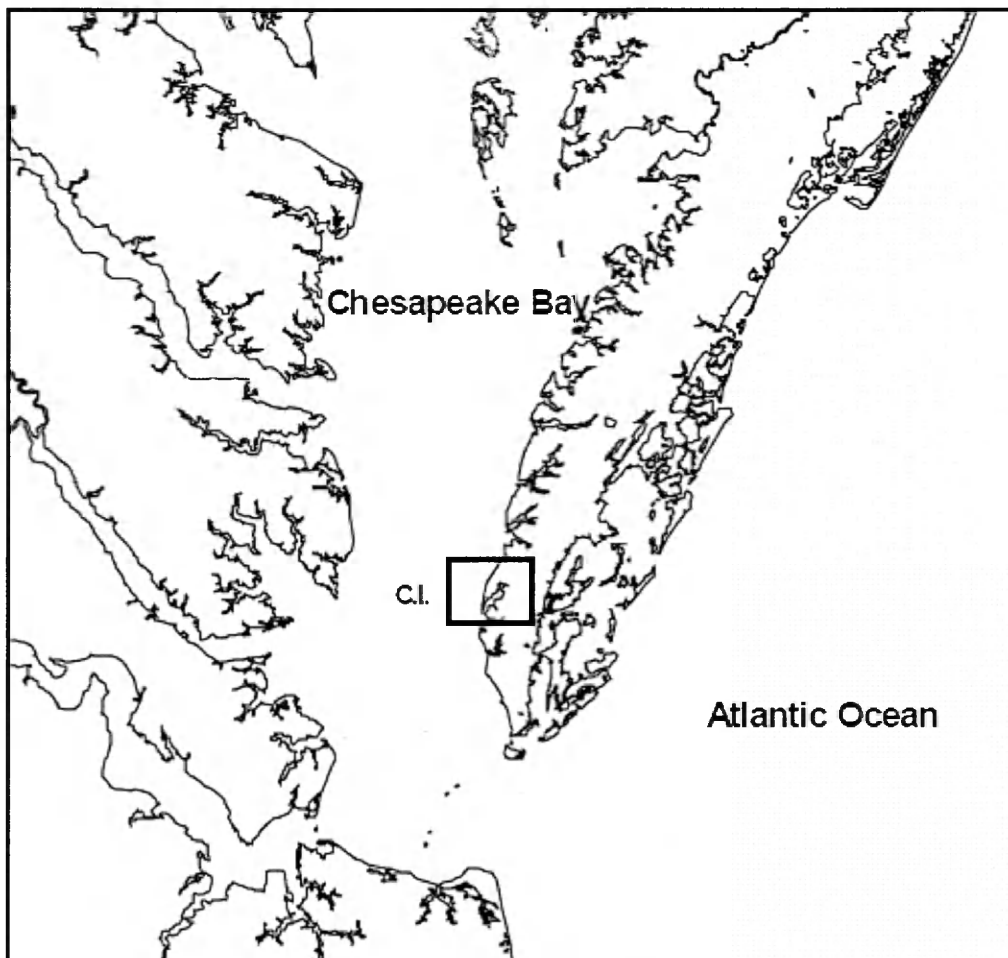

particularly in spring and fall when primary production is low relative to clam metabolic demand (Figure 2).

Predator exclusion nets covering clam beds in Cherrystone Inlet serve as an attachment point for macroalgae (Condon, 2005), particularly *Ulva* and *Gracilaria* species. Macroalgal blooms typically occur in late spring and early summer and die off in July and August due to increasing temperatures and self-shading (McGlathery et al., 1997; Higgins et al., 2008). Condon (2005) measured dissolved oxygen concentrations beneath nets on clam beds in Cherrystone Inlet ranging from 4.27 to 9.23 mg/L. These levels fluctuated over a daily cycle, peaking during daylight and often dropping below 5 mg/L at night.

Using flow-through chambers containing clams, Condon (2005) compared the clearance rates of cultured *M. mercenaria* in water sampled from under the predator exclusion nets to rates in water collected from adjacent to nets. Clams had significantly higher clearance rates in water from outside nets, which contained about 33% higher chlorophyll *a* concentrations. This suggests that clams may be experiencing food limitation under predator exclusion nets. Condon also observed that chlorophyll *a* levels in water from outside the nets were higher during ebb and flood tides compared to slack high and low tides, although not significantly. However, chlorophyll *a* levels in water below the nets were unaffected by tide (Condon, 2005). A possible reason for this difference is that the macroalgae growing on nets reduced near-bottom tidal flow and limited resuspension of benthic microalgae and detritus.

Figure 2. From Condon (2005) – Cherrystone Inlet gross primary production corrected for phytoplankton respiration (GPPc), carbon demand of clam population, and monthly averages of % GPPc needed by clams.

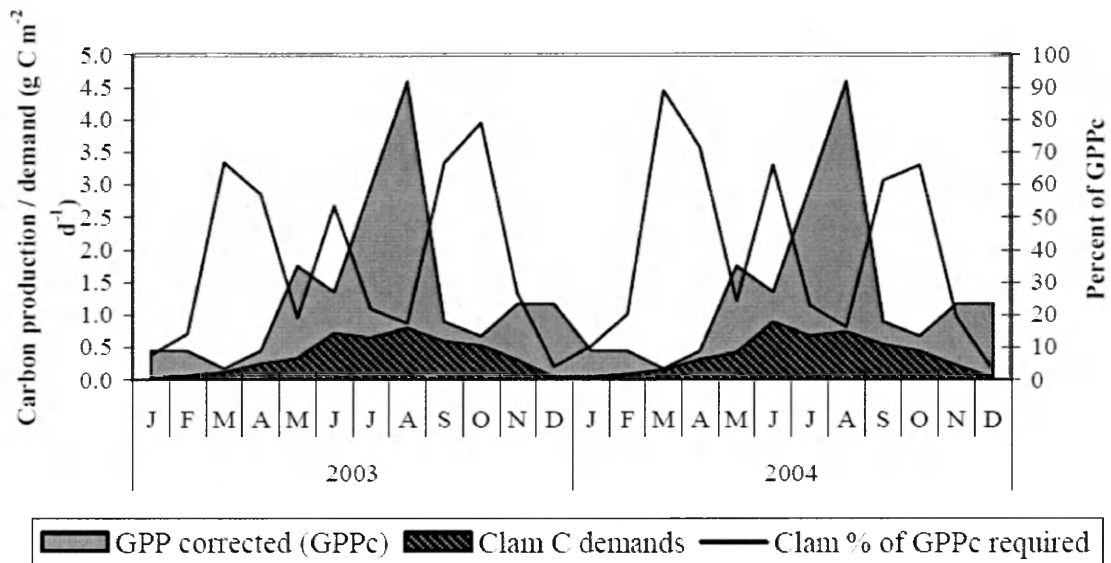

METHODS

I. Food Availability Study

Study Site and Food Availability Sampling

Field studies took place in Cherrystone Inlet, Virginia, a tidal creek on the eastern shore of the Chesapeake Bay. Studies were conducted on a clam farm located near the mouth of Cherrystone Inlet, operated by Cherrystone Aqua-Farms. This organization grows *M. mercenaria* using culture methods common throughout the east coast, including the use of plastic-mesh predator exclusion nets. The farm is comprised of about 700 clam beds, each measuring approximately 4 m x 18 m and planted at a depth of about 0.3 m at mean low water. Macroalgae, primarily *Ulva* and *Gracilaria* species, are abundant on nets in summer, and growers periodically clean macroalgae from nets using mechanical sweepers.

Seasonal field surveys of food availability were conducted in June, July, and October 2011 and March and July 2012. Samples were collected from one clam bed in June 2011 and from three replicate beds in subsequent sampling periods. Beds were randomly selected from those containing clams aged 1-2 years and that had not been recently cleared of macroalgae.

Water Sample Collection and Analyses

To determine food availability to clams under nets and compare this to food concentrations above beds, water samples were pumped both from beneath and above nets, and from similar depths at bare control sites (labeled as NetBtm, NetMid, BareBtm, and

BareMid, respectively). In July 2012, sections of clam beds cleared of macroalgae 1-2 days before sampling were used as a control area to directly compare effects of macroalgae on food availability. Intake tubes were attached to wire-frame cages to position them under nets (NetBtm) and approximately 10 cm above nets (NetMid). For each clam bed, a set of control samples was pumped concurrently from a bare area adjacent to the bed on the channel side of the farm (Figure 3). At each bed, three replicate water samples were collected for each of the four treatments. In June and July 2011, three sets of water samples were collected from each location at ebb tide, slack low tide, and flood tide to investigate effects of tide on food availability. In June samples were collected for all three tidal stages on the same day, while in July the three tidal stages were samples over 2-day periods.

Water samples were pumped through Norprene tubing (3.2 mm inner diameter) attached at the surface to peristaltic pumps. Prior to pumping, sites were left to settle for at least 1 hour after anchoring intakes. Samples were pumped at low flow velocities (approx. 2-2.5 cm/s) to minimize artificial resuspension of the benthos. Water was pumped for 30-60 minutes to obtain about 400 mL of water per sample. All samples at a clam bed and its corresponding bare control area were pumped simultaneously, between mid ebb and flood tides (with the exception of ebb tide samples in summer 2011).

Each water sample was divided into subsamples analyzed for chlorophyll *a*, phaeophytin *a*, particulate matter, and cell counts. For chlorophyll and phaeophytin measurements, 5-20 mL subsamples were filtered into two size fractions using glass fiber (0.7 μm) and polycarbonate (20 μm) filters, which were extracted and analyzed using a Turner Designs 10-AU Fluorometer (Shoaf and Lium, 1976; Arar and Collins, 1997).

Figure 3. Placement of water sampling intakes in net and bare sites. Three replicates of each of the four intake types shown were placed per site.

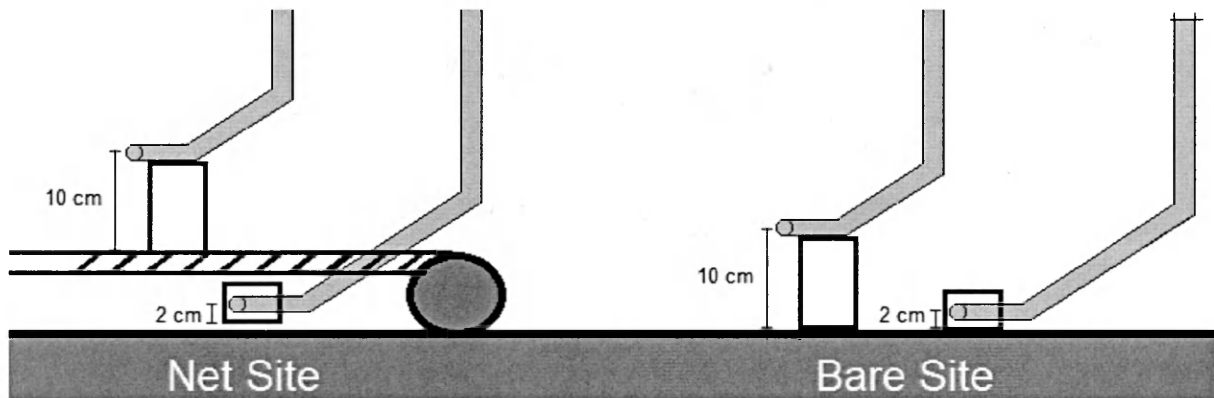

Particulate matter was also filtered (from 50-200 mL subsamples) on 0.7 μm glass fiber filters, dried at $\sim 60^\circ\text{C}$ for at least two weeks, and weighed before and after combustion for five hours in a 500°C muffle oven to calculate particulate organic matter. For cell counts, 10 mL subsamples were preserved in 6% glutaraldehyde and prepared for counting with an epifluorescence microscope as described by Haas (1982) to quantify phytoplankton, represented by centric diatoms and dinoflagellates (Lucas et al., 2001), and BMA, which consist mostly of pennate diatoms (Fryxell, 1983; Smyth, 1995; Marshall, 2009).

Macroalgae and Benthic Samples

To measure biomass per square meter on predator exclusion nets, at least three samples of macroalgae were collected from each clam bed from which food availability samples were collected. For each sample, a plastic ring (26 cm diameter) was placed haphazardly on the net, and all macroalgae within the ring were removed by hand. Each sample was divided into dominant genera (*Ulva* and *Gracilaria*) and dried to constant mass for biomass calculations.

Samples of surface sediment (top ~ 0.5 cm) were collected using plastic syringes from each bare area and under each net. Benthic chlorophyll levels were measured on a Beckman Coulter DU 800 Spectrophotometer (Lorenzen, 1967). Sediment for cell counts was placed in filtered ($0.45 \mu\text{m}$) site water and preserved with Lugol's solution. Cells were separated from sediment by placing sample vials in an ice bath sonicator, then collecting water by pipette after sediment had settled. Relative abundances of centric and pennate diatoms were counted using light microscopy.

II. Feeding Experiments

Three feeding experiments were conducted on individual cultured clams in static containers to compare the value of four food sources to cultured clams: (1) phytoplankton, (2) benthic microalgae, (3) *Ulva* detritus, and (4) *Gracilaria* detritus. The first two experiments, conducted in August and September 2012, compared clearance rates and absorption efficiencies for these food sources individually. In October 2012, a third experiment was conducted using mixtures of phytoplankton, benthic microalgae, and macroalgal detritus. Clearance rates were measured for each source simultaneously to determine feeding preferences.

Diet Preparation

For phytoplankton treatments, the centric diatom *Chaetoceros neogracile* was purchased from the National Center for Marine Algae and Microbiota and cultured in the laboratory under fluorescent lights. Diatoms were about 4-8 μm in length. Similar-sized centric diatoms were common in the food availability field study, including some *Chaetoceros spp.* in July 2011 and July 2012. One week prior to experiments, cultures were grown to a concentration of about $1-2 \times 10^6$ cells/mL. Benthic microalgae for the individual food source experiments were collected from mudflats near Wachapreague, VA by placing 153-300 μm nitex on sediment surfaces for at least 1 hour. Nitex sheets were rinsed with 1 μm filtered seawater into buckets, and these solutions were decanted into new buckets before dilution into treatment containers. In the first experiment BMA were collected in the field on a falling tide. For the second experiment sediment was placed in trays and covered with

nitex, along with thin layers of combusted above and below nitex sheets. Trays were placed under fluorescent lights for collection of BMA. To obtain larger concentrations of BMA for the third experiment, patches of sand were collected on falling tides from a beach on the York River in Gloucester Point, VA. Sand was placed in trays, covered with plastic wrap, and placed in a lighted environmental chamber at about 25°C. After about 36 hours, surface sediment (about 0.5 cm) was scraped into buckets of 1 µm filtered seawater. For all experiments, hemocytometer counts of stock solutions were used to determine final concentrations of *C. neogracile* and benthic diatoms in experiments.

For macroalgal detritus diets, samples of two macroalgae genera, *Ulva* and *Gracilaria*, were dried, ground using a food processor, and mixed into an artificial seawater solution (29.3 g NaCl, 9.4 g MgSO₄·7H₂O, and 0.22 g NaHCO₃ per L of water) with a salinity of ~25. Solutions were filtered through 63 µm nitex to remove larger particles and refrigerated until feeding experiments were conducted. For the third experiment, macroalgae were labeled with ¹⁵N so that macroalgal clearance could be measured independently of other food sources in mixtures. Macroalgae were starved in aquaria for 5 days and fed mixtures of ¹⁴N and ¹⁵N-ammonium sulfate (99 atom %) for about 20 hours under natural light conditions in a greenhouse to enrich macroalgal tissue to 1-2 atom% ¹⁵N. Final percentages of ¹⁵N-ammonium sulfate (by mole) in ammonium sulfate mixtures fed to macroalgae were 26.7% and 70.4% for *Ulva* and *Gracilaria*, respectively.

Experimental Design

Feeding experiments were conducted at the seawater laboratory of the Virginia Institute of Marine Science Eastern Shore Lab in Wachapreague, VA. Feeding solutions

were maintained at similar temperatures and salinities in all three experiments, as both factors affect clam pumping rates (Grizzle et al., 2001). Filtered (1 μm) seawater was diluted with freshwater (also filtered to 1 μm) to a salinity of about 25 for all experiments (salinities of 21-24 were recorded during July 2012 field sampling). Clams ranging in length from 32 to 52 mm were collected from the Cherrystone Aqua-Farms site and placed in aquaria for 24 hours to allow clams to acclimate and clear their guts. Feeding treatments were mixed in plastic buckets oxygenated with air stones. Treatment solutions remained between 22.1 and 23.7°C (ambient temperature) during the first two experiments. For consistency between experiments, heated water baths were used to maintain solutions within this range during the third experiment. During feeding periods for clearance rate measurements, containers were covered with plastic tarps in daylight hours to keep treatments in the dark. For each food source, 10 replicate buckets, each with one clam, were tested (with the exception of BMA, for which 6 and 5 replicates were used in the first and second experiments, respectively). Three control buckets without clams were monitored concurrently for each food source.

Feeding Measurements

Clearance rate was determined in all experiments by measuring initial food concentration prior to addition of clams and at two to three periods (described below) after clams were added. Water samples were collected by gently stirring containers and pulling samples with a syringe through plastic tubing. Chlorophyll *a* levels were measured in each water sample as described for field studies, and were used to determine which clams were actively feeding. Clearance rates were calculated only for active feeders. A clam was considered actively feeding if the rate of chlorophyll decrease over a given time interval was

2 standard deviations above the mean chlorophyll decrease of the three control buckets during the same time interval. Clearance rates were calculated according to the following equation from Coughlan (1969):

$$F = [(V/t) \times \ln(C_0 / C_t)] - a$$

where F is clearance rate in $L h^{-1}$, V is the volume of the container in L, t is the time interval in hours, C_0 and C_t are the initial and final concentrations of the food source, and a is the mean of the settling rates in control containers (F calculated for each control). Only time intervals during which clams were actively feeding were used in clearance rate calculations. To account for effects of clam size on clearance rate, calculated rates for each clam were divided by its dry tissue mass.

Clam absorption efficiencies for individual food sources were determined using the Conover method, comparing the organic and inorganic fractions of the food source and clam feces (Conover, 1966; Cranford and Grant, 1990; Navarro and Thompson, 1994; Iglesias et al., 1998). Initial food solutions and feces (collected by pipette about 12-24 hours after addition of clams) were each filtered onto 1.6 μm glass fiber filters, and organic content was determined as described for particulate matter in field studies.

Individual Food Source Experiments

The volumes and approximate starting concentrations of treatment solutions for the individual food source experiments are given in Table 1. Kaolinite was added to each treatment to supplement the inorganic content of food solutions for the Conover method. In these experiments, chlorophyll a concentrations (on 5 μm polycarbonate filters) were used to represent food concentration values in clearance rate calculations. In the first experiment,

water samples were collected at about 1 hour intervals (1 and 2 hours into the experiment) for phytoplankton and BMA, and at about 4 hour intervals (4 and 8 hours into the experiment) for macroalgae. In the second experiment, samples were collected at about 1 to 1.5 hour intervals (1, 2, and 2.5 hours into the experiment) for phytoplankton and BMA and about 2 hour intervals (2, 4, and 6 hours into the experiment) for macroalgae. Exact times of each sample were recorded and used for clearance rate calculations.

Mixed Food Source Experiment

Two mixed solutions were tested, each a mixture of phytoplankton, BMA, and one genera of ¹⁵N-labeled ground macroalgae (either *Ulva* or *Gracilaria*). The concentration of each of the three food sources in mixtures (Table 2) was calculated such that each source would have approximately equal organic matter contents in the final mixture. Organic content was estimated for phytoplankton (2.4×10^{-7} mg C/cell, using data from experiment 1), BMA (1.1×10^{-6} mg C/cell, measured from BMA collected for experiment 3). Percent organic content was estimated to be 50% for *Ulva* and 63% for *Gracilaria* using data from experiment 1. Water volumes for all treatments were 2 L, and were carried out in 5 L plastic buckets. Cell concentrations (measured as described for field studies) of *Chaetoceros neogracile* and pennate diatoms were used for calculating clearance rates of phytoplankton and benthic microalgae, respectively. Concentrations of ¹⁵N (in mg ¹⁵N per mL) were used for clearance rate calculations for labeled macroalgal detritus. All water samples for this experiment were filtered on 2.3 μm glass fiber filters, and collected at 1-2 hour increments (1 and 2 hours into the experiment for *Ulva* mixtures, and 1 and 3 hours into the experiment for

Table 1. Water volumes and approximate concentrations of initial food treatments in individual food source experiments.

Treatment	Experiment 1 (Aug. 2012)			Experiment 2 (Sep. 2012)		
	Water Volume (L)	[Food]	[Kaolinite] (mg/L)	Water Volume (L)	[Food]	[Kaolinite] (mg/L)
Phytoplankton	2	5×10^4 cells/mL	3	2	1.8×10^4 cells/mL	2
BMA	2	2.5×10^4 cells/mL	3	1.6	0.6×10^4 cells/mL	2
Ground <i>Ulva</i>	10	6 mg/L	3	10	1.5 mg/L	1.5
Ground <i>Gracilaria</i>	10	4.8 mg/L	3	10	1.5 mg/L	1.5

Table 2. Approximate concentrations of feeding solutions in the mixed food experiment, including estimates of organic matter concentration determined by measuring the % organic content of feeding solutions of known food concentrations.

Treatment	[Phytoplankton]		[BMA]		[Ground Macroalgae]	
	cells / mL	mg OM / cell	cells / mL	mg OM / cell	mg / L	mg OM / cell
<i>Ulva</i> Mixture	1.45 x 10 ⁴	0.0035	0.34 x 10 ⁴	0.0037	7	0.0035
<i>Gracilaria</i> Mixture	0.7 x 10 ⁴	0.0017	0.16 x 10 ⁴	0.0018	2.7	0.0017

Gracilaria mixtures). Filters for measuring ^{15}N concentrations were analyzed on a Costech Instruments Elemental Combustion System attached to a Finnigan Delta-V isotope ratio mass spectrometer.

Statistical Analyses

For field studies, combinations of the two locations (clam bed and bare) and two heights (~2 cm and 10 cm above the bed) were used to define four treatment types (NetBtm, NetMid, BareBtm, and BareMid) and one-way ANOVAs (or nonparametric Kruskal-Wallis tests, when assumptions of ANOVA were not met) were used to compare mean values from each treatment for each sampling period. This was considered more appropriate than two-way comparisons testing location and height above the bed independently as food availability above and below nets may be affected by the macroalgae growing above nets in addition to height above the bed. Although water sample parameters did not meet assumptions of ANOVA in all sampling periods, preliminary two-way ANOVAs testing treatment type and sampling period indicated significant interaction terms for concentrations of $0.7\ \mu\text{m}$ chlorophyll ($p = 1.91 \times 10^{-5}$), centric diatoms ($p = 0.0154$), and particulate organic matter ($p = 4.89 \times 10^{-6}$). Consequently, the data were analyzed separately within each sampling period.

Comparisons of macroalgal biomass across sampling periods, and of laboratory clearance rates and absorption efficiencies, were also made using one-way ANOVAs when assumptions were met. If assumptions were not met, data were transformed (natural logarithm, or square root) prior to analysis. If assumptions were still not met, a Kruskal-Wallis rank sum test was used. Post-hoc tests for ANOVAs included Tukey multiple comparisons and Bonferroni pairwise comparisons. Pairwise comparisons using Wilcoxon

rank sum tests, with the Bonferroni method of p-value adjustment, were used as post-hoc tests for Kruskal-Wallis tests. For June and July 2011, two-way ANOVAs were also used to compare diatom concentrations across the four treatment areas and three tidal stages. Unpaired t-tests or Wilcoxon rank sum tests were used to compare benthic samples between clam bed and control sites, and paired tests were used to compare centric and pennate counts in benthic samples. Linear regressions were used to compare diatom concentrations, macroalgal biomass, and water sample parameters by clam bed.

RESULTS

I. Food Availability Study

Macroalgal Biomass

Biomass of macroalgae on predator exclusion nets was highest in summer of 2011 (Figure 4). Mean biomass per unit area peaked in June 2011, but was very patchy and not significantly different than any other sampling period. July 2011 biomass was significantly higher than subsequent months (Kruskal-Wallis, $p = 2.34 \times 10^{-5}$, Wilcoxon post-hoc $\alpha = 0.05$). Biomasses of dominant genera (*Ulva* and *Gracilaria*) were also significantly higher in July 2011 than subsequent months, with the exception of *Gracilaria* in July 2012 (Kruskal-Wallis, $p = 4.66 \times 10^{-5}$, Wilcoxon post-hoc $\alpha = 0.05$). *Ulva* biomass after summer 2011 remained negligible (less than 1 g/m^2).

Figure 4. Macroalgal dry weight biomass on clam beds for total macroalgae, *Ulva* spp., and *Gracilaria* spp. Values are mean \pm standard error. Significant differences indicated between total biomasses (capital letters) and among genera (lowercase letters).

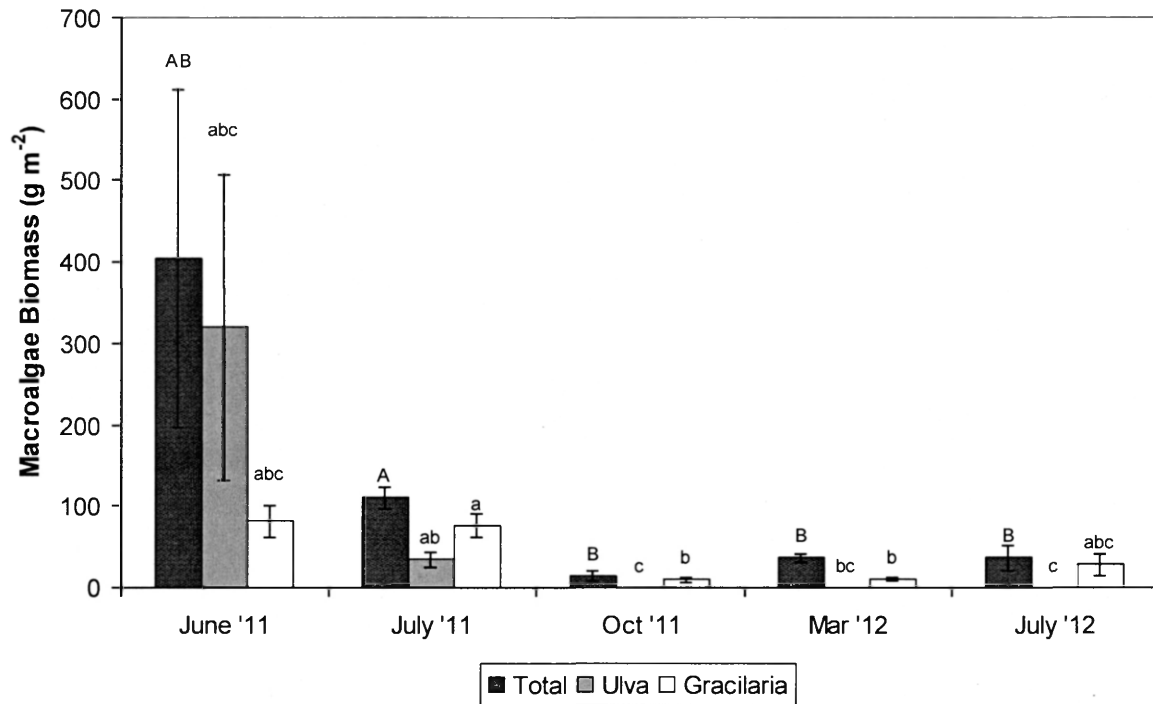

Water Column Samples

Centric and pennate diatom concentrations, and chlorophyll *a*, phaeophytin *a*, and particulate organic matter levels were compared between treatment areas (NetMid, NetBtm, BareMid, BareBtm) for each sampling period (Table 3). Water column samples were dominated by small centric and pennate diatoms less than 16 μm in length. Mean concentrations of pennate diatoms were similar to or greater than mean centric diatom concentrations in all sampling periods except March 2012 (Figure 5), with mean pennate:centric ratios ranging between 1.1 and 7.9 in summer and fall sampling periods. For June and July 2011, two-way ANOVAs comparing diatom concentrations over three tidal stages and the four treatment areas showed significant differences between treatment areas ($p = 0.00264$ in June, $p = 0.0345$ in July) but not between tidal stages ($p = 0.103$ in June, $p = 0.231$ in July), nor was there a significant interaction between factors ($p = 0.947$ in June, $p = 0.485$ in July). In summer 2011, overall diatom concentrations were lower underneath aquaculture nets than above clam beds or in control sites. In June 2011, diatoms were significantly less abundant under nets compared to above nets for both centrics (one-way ANOVA, $p = 0.0105$, Bonferroni pairwise comparison post-hoc $\alpha = 0.05$) and pennates (Kruskal-Wallis, $p = 0.000788$, pairwise Wilcoxon post-hoc $\alpha = 0.05$).

Conversely, levels of chlorophyll and phaeophytin (0.7 and 20 μm fractions), as well as particulate organic matter (Figure 6), tended to be higher under nets compared to the other three treatment areas in summer 2011. In June 2011, 0.7 μm chlorophyll was significantly higher under nets compared to above (one-way ANOVA, $p = 0.00198$, Bonferroni pairwise comparison post-hoc $\alpha = 0.05$). In June and July 2011, levels of 20 μm chlorophyll,

Table 3. Statistical comparisons of water sample parameters. The four treatment locations, under predator exclusion nets (NetBtm), above nets (NetMid), and similar depths at control sites (BareBtm and BareMid, respectively) were compared for each sampling period. For July 2012, control sites were sections of clam beds cleared of macroalgae (ClearBtm and ClearMid).

Sampling Period	Parameter	Significant Differences	Test
June 2011	Centrics	NetMid, BareMid > NetBtm	ANOVA, $p = 0.0105$, Bonferroni post-hoc
	Pennates	NetMid > NetBtm, BareMid	KW, $p = 0.000788$, Wilcoxon post-hoc
	0.7 μm Chl	NetBtm, BareMid, BareBtm > NetMid	ANOVA, $p = 0.00198$, Bonferroni post-hoc
	20 μm Chl	NetBtm > NetMid, BareMid	ANOVA, $p = 0.000156$, Bonferroni post-hoc
	0.7 μm Phaeo	NetBtm > NetMid, BareMid, BareBtm	KW: $p = 2.64 \times 10^{-6}$, Wilcoxon post-hoc
	20 μm Phaeo POM	NetBtm > NetMid, BareMid, BareBtm	KW, $p = 0.000159$, Wilcoxon post-hoc ANOVA, $p = 0.000307$, Bonferroni post-hoc
July 2011	Centrics	BareMid, BareBtm > NetBtm	ANOVA, $p = 0.00252$, Bonferroni post-hoc
	Pennates	BareBtm > NetBtm	ANOVA, $p = 0.0149$, Bonferroni post-hoc
	0.7 μm Chl	-	KW, $p = 0.192$
	20 μm Chl	NetBtm > NetMid, BareMid, BareBtm	KW, $p = 9.11 \times 10^{-6}$, Wilcoxon post-hoc
	0.7 μm Phaeo	NetBtm > NetMid, BareMid, BareBtm	KW, $p = 1.98 \times 10^{-5}$, Wilcoxon post-hoc
	20 μm Phaeo POM	NetBtm > NetMid, BareMid, BareBtm NetBtm > NetMid	KW, $p = 3.80 \times 10^{-7}$, Wilcoxon post-hoc KW, $p = 0.0319$, Wilcoxon post-hoc
October 2011	Centrics	-	ANOVA, $p = 0.856$
	Pennates	-	KW, $p = 0.0174$, Wilcoxon post-hoc (no significance)
	0.7 μm Chl	-	KW, $p = 0.486$
	20 μm Chl	-	ANOVA, $p = 0.728$
	0.7 μm Phaeo	-	KW, $p = 0.0110$, Wilcoxon post-hoc (no significance)
	20 μm Phaeo POM	- NetBtm > BareMid, BareBtm	KW, $p = 0.00486$, Wilcoxon post-hoc (no significance) ANOVA, $p = 0.0236$, Bonferroni post-hoc
March 2012	Centrics	BareMid, BareBtm > NetMid, NetBtm	ANOVA, $p = 0.000138$, Tukey post-hoc
	Pennates	-	ANOVA, $p = 0.371$
	0.7 μm Chl	BareMid, BareBtm > NetBtm; BareMid > NetMid	ANOVA, $p = 8.41 \times 10^{-5}$, Tukey post-hoc
	20 μm Chl	BareMid, BareBtm > NetBtm	ANOVA, $p = 0.00105$, Tukey post-hoc
	0.7 μm Phaeo	-	KW, $p = 0.501$
	20 μm Phaeo POM	- -	ANOVA, $p = 0.262$ ANOVA, $p = 0.335$
July 2012	Centrics	-	KW, $p = 0.855$
	Pennates	-	ANOVA, $p = 0.106$
	0.7 μm Chl	NetMid, ClearMid > NetBtm, ClearBtm	KW, $p = 2.65 \times 10^{-5}$, Wilcoxon post-hoc
	20 μm Chl	-	KW, $p = 0.0789$
	0.7 μm Phaeo	-	KW, $p = 7.80 \times 10^{-3}$, Wilcoxon post-hoc (no significance)
	20 μm Phaeo POM	- -	KW, $p = 0.0789$ KW, $p = 0.0772$

Figure 5. Concentrations of centric and pennate diatoms above and below aquaculture nets and similar depths at control sites. Controls were bare areas near clam beds for all sampling periods except July 2012, for which portions of clam beds cleared of macroalgae were used as controls. Values are mean \pm standard error.

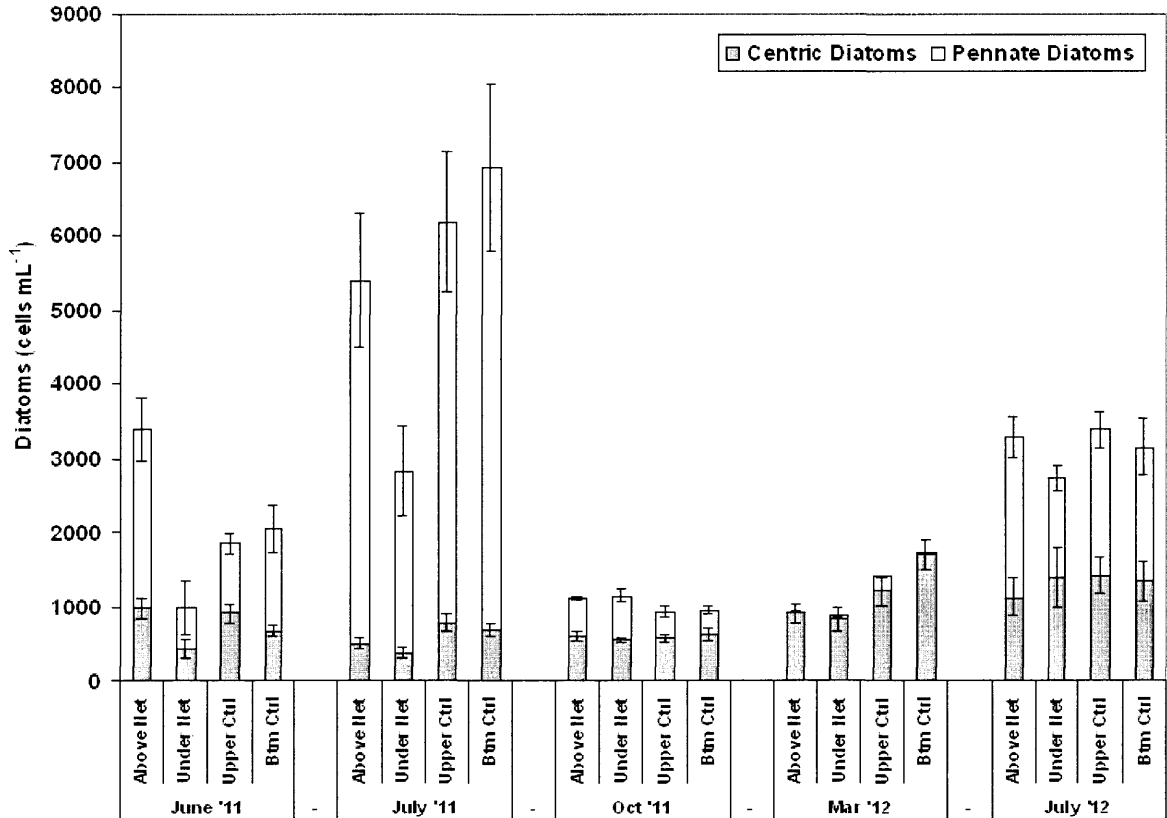
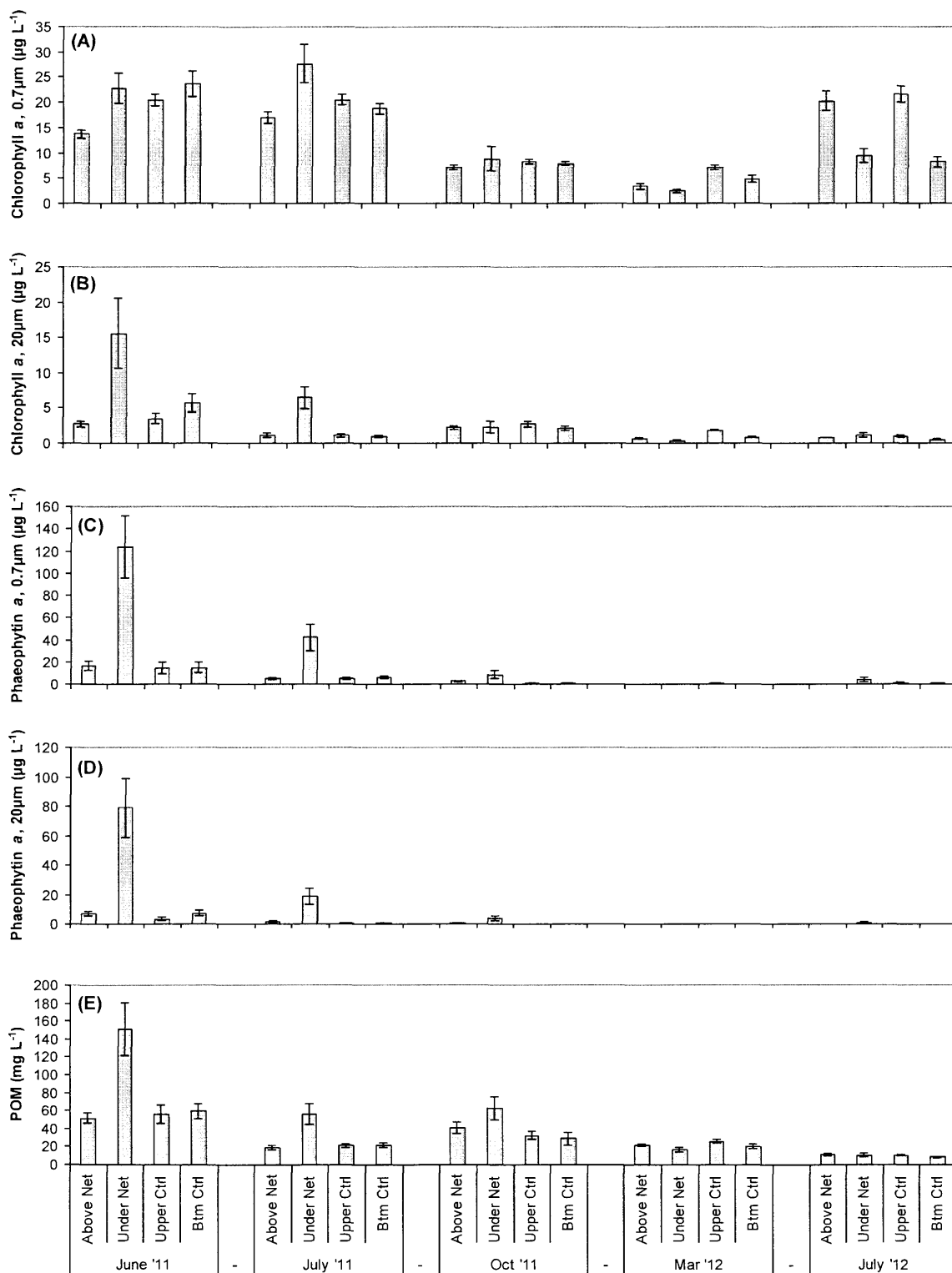

Figure 6. Water sample parameters above and below aquaculture nets and similar depths at control sites. Controls were bare areas near clam beds for all sampling periods except July 2012, for which portions of the clam bed cleared of macroalgae were used as controls. Chlorophyll concentrations were measured in size fractions of 0.7 μm (A) and 20 μm (B). Phaeophytin was measured in the same fractions (C and D, respectively) and particulate organic matter was filtered at 0.7 μm (E). Values are mean \pm standard error.



phaeophytin (both size fractions), and particulate organic matter were all significantly higher under nets compared to above, and in most cases were also higher than bare control sites (see Table 3).

Comparisons of Food Availability Indicators

Linear regressions were used to compare both diatom concentrations under nets and macroalgal biomass on clam beds with other water sample parameters used as indicators of food availability. Total diatom concentrations were not significantly related to chlorophyll *a* (0.7 μm fraction, $p = 0.111$) or particulate organic matter ($p = 0.977$) under nets. Macroalgal biomass was not significantly related with chlorophyll *a* ($p = 0.102$), but a significant relationship was observed with particulate organic matter under nets (Figure 7). All regressions involving macroalgal biomass were likely driven by the high mean macroalgal biomass observed in June 2011.

Macroalgal biomass was compared with phaeophytin levels (both size fractions) under nets, as well as chlorophyll levels in the 20 μm fraction, and significant relationships were found with all three parameters (Figures 8-10). A significant inverse relationship was observed between macroalgal biomass and benthic chlorophyll (Figure 11). Macroalgal biomass was not related to centric ($p = 0.552$) or pennate ($p = 0.791$) diatom concentrations under nets, but a marginally significant relationship was observed with the difference between total diatom concentrations above and below nets (Figure 12).

Figure 7. Comparison of macroalgal biomass on clam beds and particulate organic matter under predator exclusion nets for all sampling periods. Each point represents mean values for one clam bed. $R^2 = 0.590$, $p = 0.00355$.

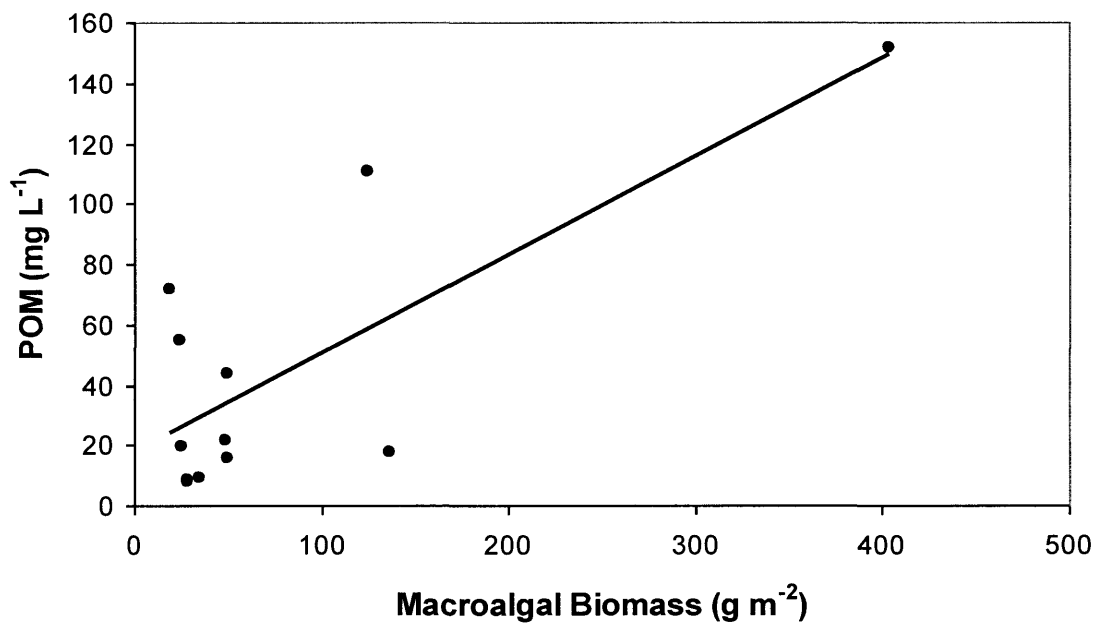

Figure 8. Comparison of macroalgal biomass on clam beds and chlorophyll *a* (20 μm fraction) under predator exclusion nets for all sampling periods. Each point represents mean values for one clam bed. $R^2 = 0.790$, $p = 0.000110$.

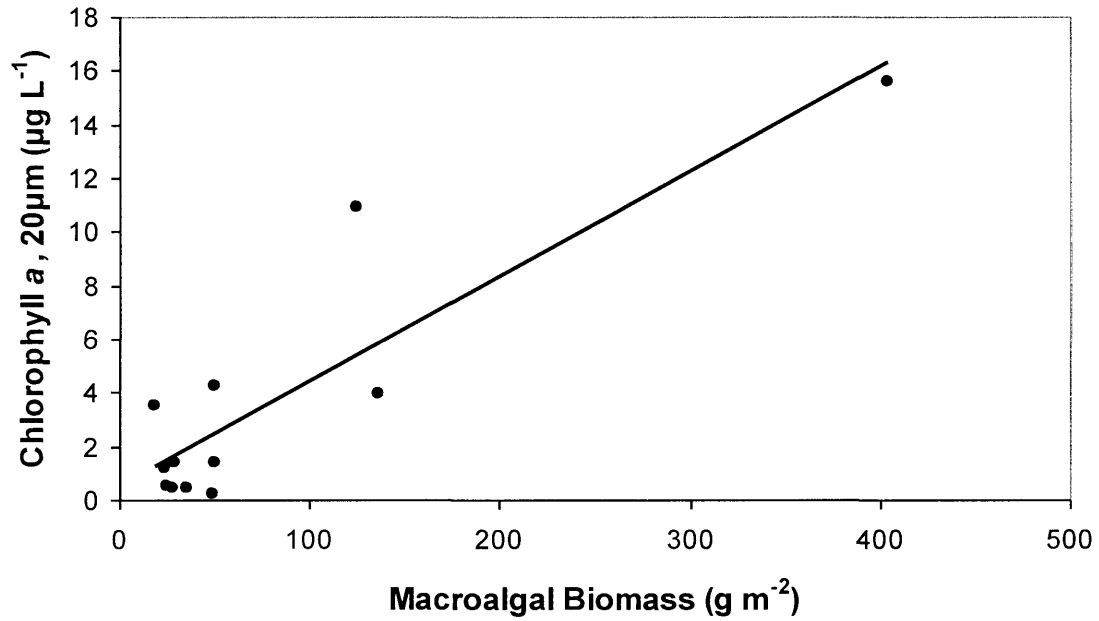

Figure 9. Comparison of macroalgal biomass on clam beds and phaeophytin *a* (0.7 μm fraction) under predator exclusion nets for all sampling periods. Each point represents mean values for one clam bed. $R^2 = 0.755$, $p = 0.000242$.

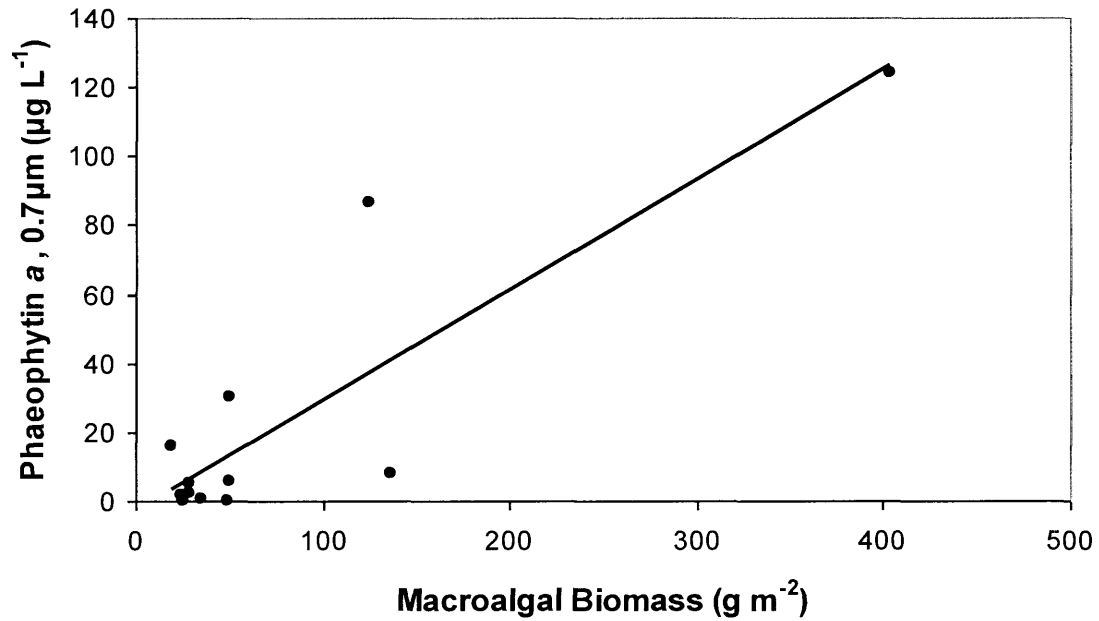

Figure 10. Comparison of macroalgal biomass on clam beds and phaeophytin *a* (20 μm fraction) under predator exclusion nets for all sampling periods. Each point represents mean values for one clam bed. $R^2 = 0.871$, $p = 9.24 \times 10^{-6}$.

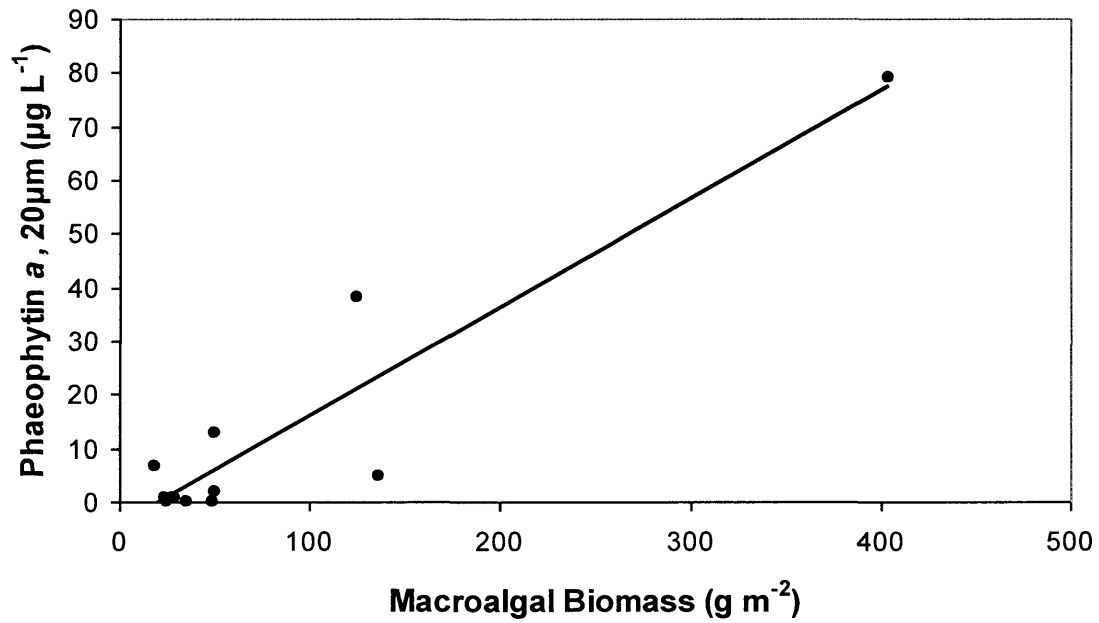

Figure 11. Comparison of macroalgal biomass on predator exclusion nets and benthic chlorophyll *a* on clam beds, for July 2011, March 2012, and July 2012. Each point represents mean values for one clam bed. $R^2 = 0.521$, $p = 0.0282$.

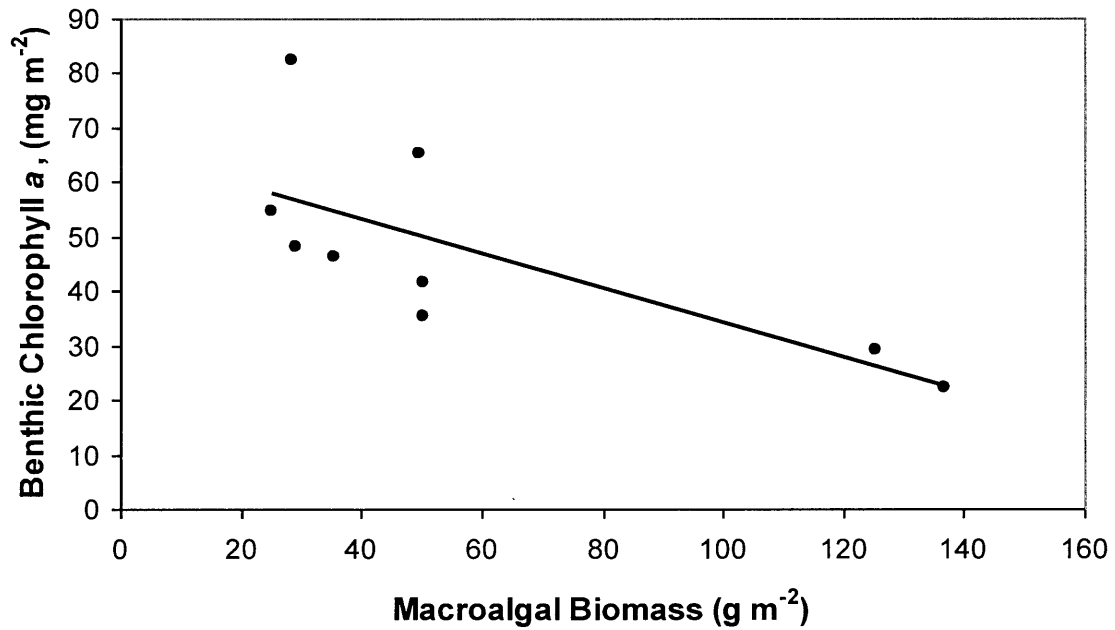
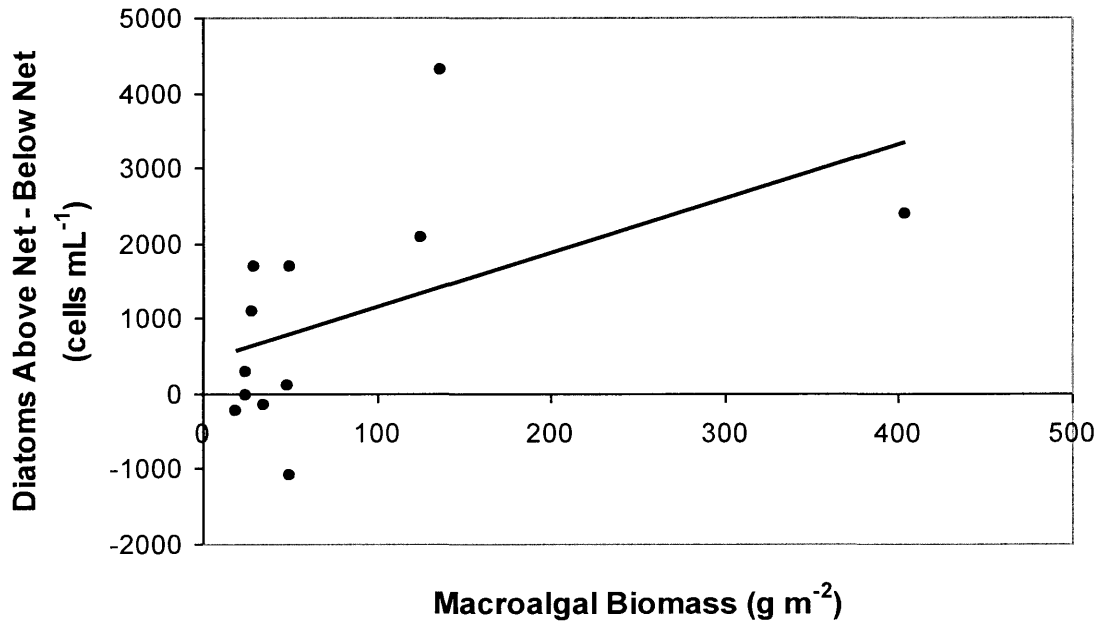

Figure 12. Comparison of macroalgal biomass on clam beds and with the difference between total diatom concentrations above and below predator exclusion nets for all sampling periods. Each point represents mean values for one clam bed. $R^2 = 0.277$, $p = 0.0785$.



Benthic Samples

Benthic chlorophyll *a* and phaeophytin *a* levels were compared between net and control sites for three sampling periods (Figure 13). For chlorophyll, no significant differences were found (two-tailed t-test) for July 2011 ($p = 0.164$), March 2012 ($p = 0.531$), or July 2012 (cleared and un-cleared nets, $p = 0.270$). Phaeophytin was significantly higher at clam beds for July 2011 (one-tailed t-test, $p = 6.00 \times 10^{-5}$) and March 2012 (Wilcoxon test, $p = 0.0122$). In July 2012, phaeophytin levels were higher in cleared clam beds, but the difference was marginally significant ($p = 0.0562$).

For four sampling periods, a paired t-test was used to compare pennate and centric diatom counts (Figure 14) in each sediment sample (including clam bed and bare area samples). Pennate counts were significantly higher for June 2011 (one-tailed t-test, $p = 0.00238$), October 2011 (one-tailed t-test, $p = 1.33 \times 10^{-5}$), March 2012 (one-tailed Wilcoxon test, $p = 9.54 \times 10^{-5}$), and July 2012 (cleared and un-cleared nets, one-tailed t-test, $p = 8.23 \times 10^{-13}$). However, the mean clam bed pennate:centric ratio in March was about 1:1. Pennate:centric ratios for net and control sites were not significantly different in June 2011 (two-tailed t-test, $p = 0.980$), October 2011 (one-tailed t-test, $p = 0.129$), or July 2012 (cleared and un-cleared nets, one-tailed Wilcoxon test, $p = 0.365$). Ratios were significantly higher in bare sites in March 2012 (one-tailed Wilcoxon test, $p = 2.06 \times 10^{-5}$).

Figure 13. Benthic chlorophyll *a* (top) and phaeophytin *a* (bottom) at clam beds (dark gray bars), bare control sites (white bars), and clam beds cleared of macroalgae (light gray bars, July 2012). Values are mean \pm standard error. No significant differences were found in any sampling periods for benthic chlorophyll, while phaeophytin concentrations in clam beds were significantly different from controls in all sampling periods. * indicates significant difference between clam bed and control sites during that sampling period (t-test, $\alpha < 0.05$).

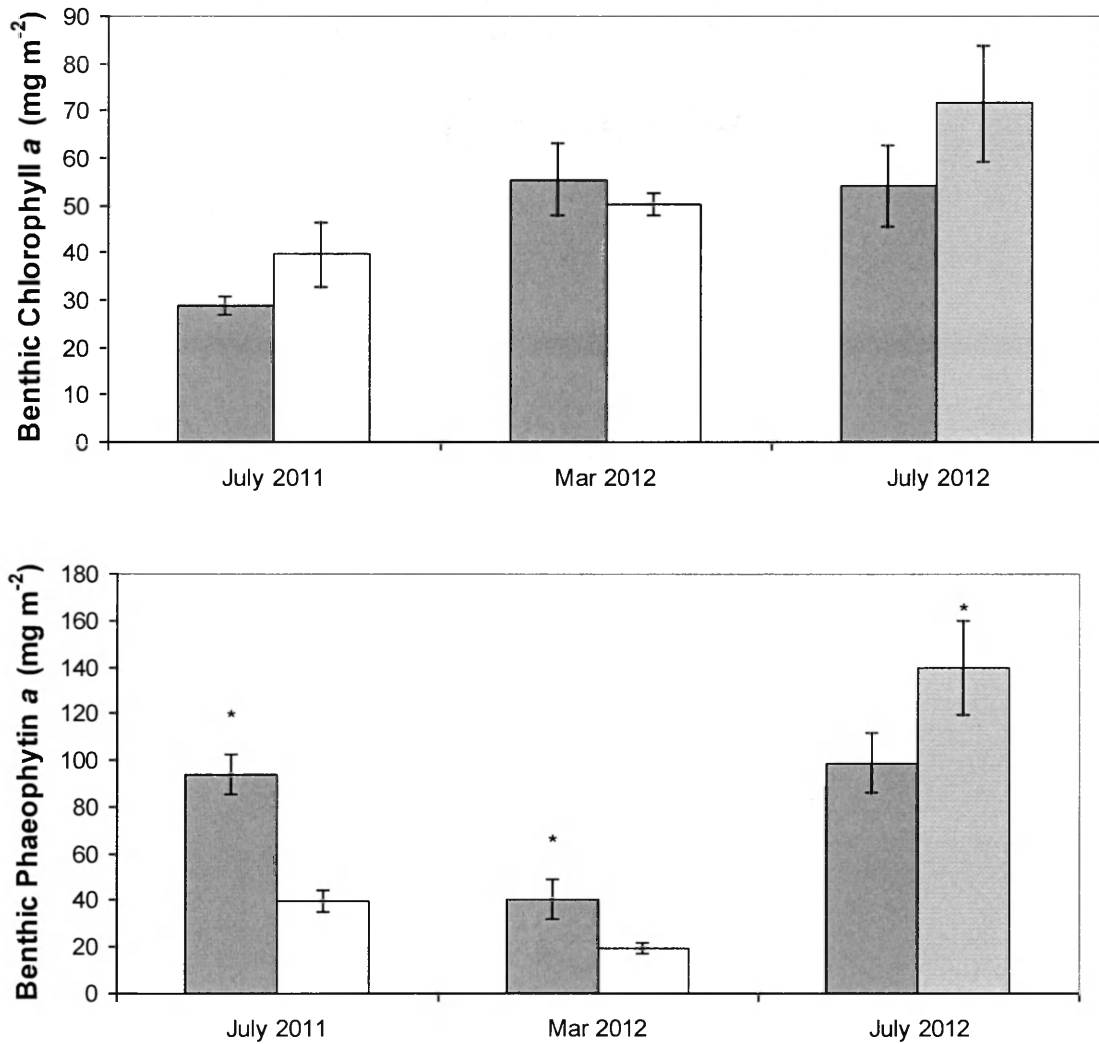
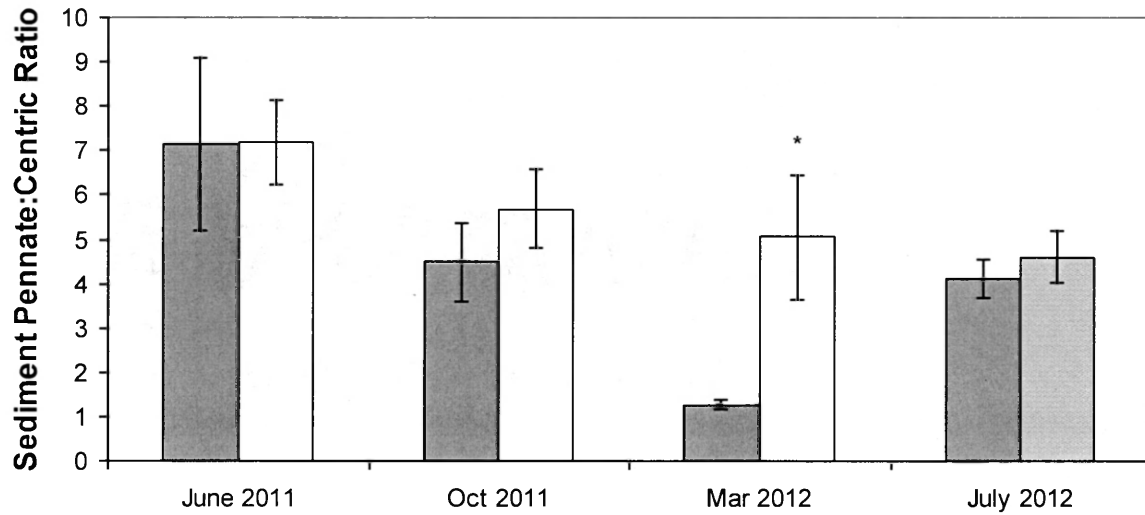

Figure 14. Pennate-to-centric diatom ratios in sediment samples from clam beds (dark gray bars), bare control sites (white bars), and clam beds cleared of macroalgae (light gray bars, July 2012). Values are mean \pm standard error. * indicates significant difference between clam bed and control sites during that sampling period (t-test, $\alpha < 0.05$).



II. Feeding Experiments

Clearance Rates

In feeding experiments, between 20 and 75% of total clams fed each food treatment were determined to be feeding during measurements of clearance rates (Figure 15). The fraction of clams feeding was not independent of food treatment (Pearson's Chi-squared test of independence, $p = 0.00406$), and the percent feeding on phytoplankton was more than double that of other individual food sources.

Mass-specific clearance rates for individual food sources were averaged across all clams determined to be feeding in experiments 1 and 2 (Figure 16). Clearance rates on *Ulva* were significantly higher than phytoplankton and BMA (one-way ANOVA, $p = 0.00565$, Bonferroni post-hoc $\alpha = 0.05$). In mixtures of phytoplankton, BMA, and *Ulva* (Figure 17), lower clearance rates were observed for each source individually compared to rates measured with a single food source. No significant differences in rates were observed for this mixture (one-way ANOVA, $p = 0.128$). For mixtures of phytoplankton, BMA, and *Gracilaria* (Figure 17), rates were also lower for phytoplankton and *Gracilaria* compared to individual food source rates. Mean *Gracilaria* clearance rate was lower than phytoplankton and BMA rates, though due to the low percentage of clams feeding in this mixture, rates between food sources could not be compared statistically. However, clearance rates on phytoplankton were similar to phytoplankton observed in the mixture with *Ulva*, and rates for each macroalgal genera were similar in their respective mixes.

Figure 15. Percent of clams determined to be feeding during clearance rate measurements, by food treatment. 20 clams were tested for each individual food source (experiments 1 and 2) and 10 clams for each of the two mixed treatments in experiment 3 (each a mixture of phytoplankton, BMA, and one of the two macroalgae genera).

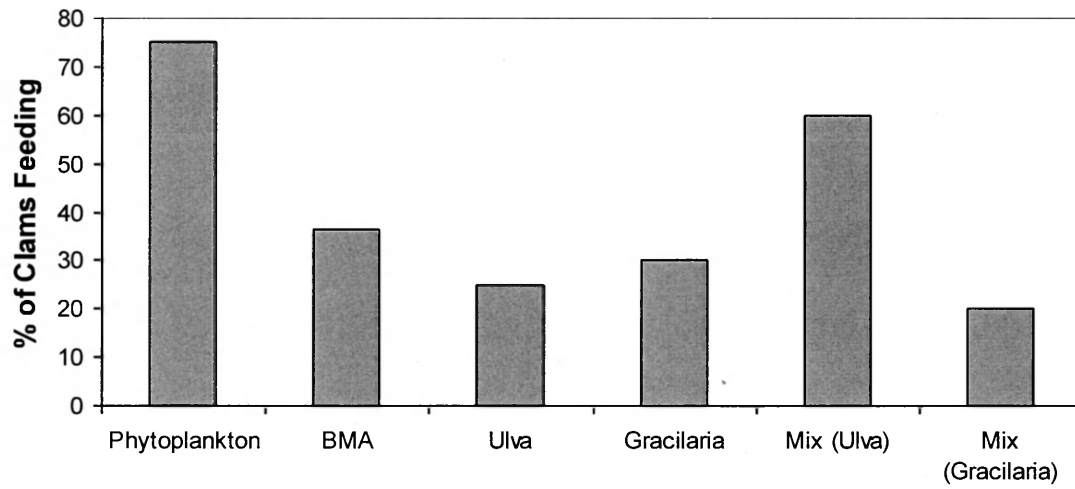

Figure 16. Mass-specific clearance rates (per gram dry tissue weight of clam) on individual food sources from experiments 1 and 2. Values are mean \pm standard error. Letters indicate significant differences.

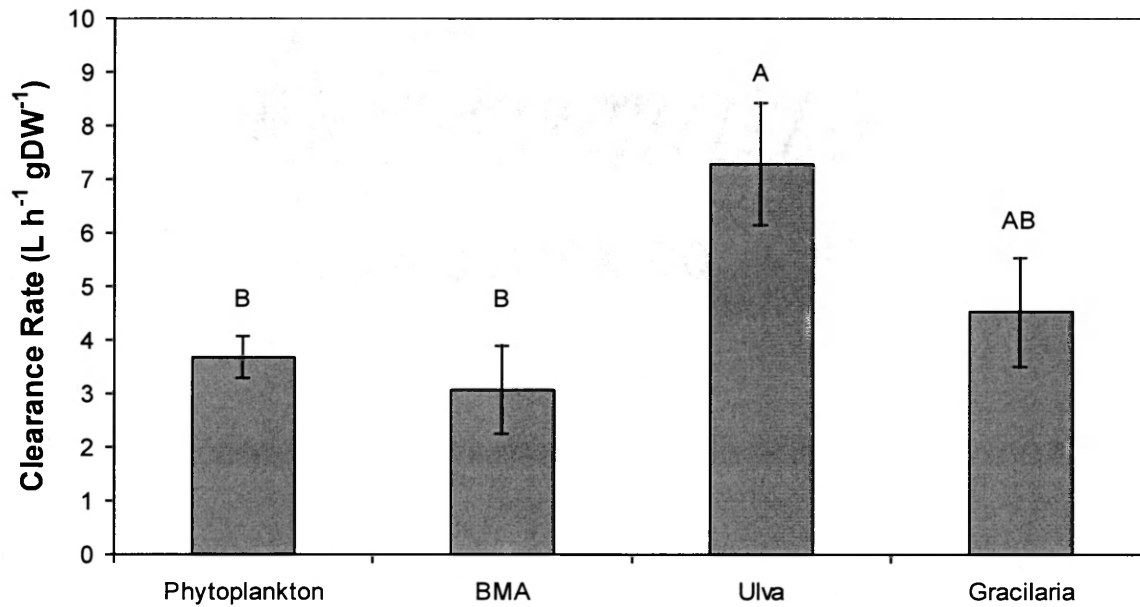
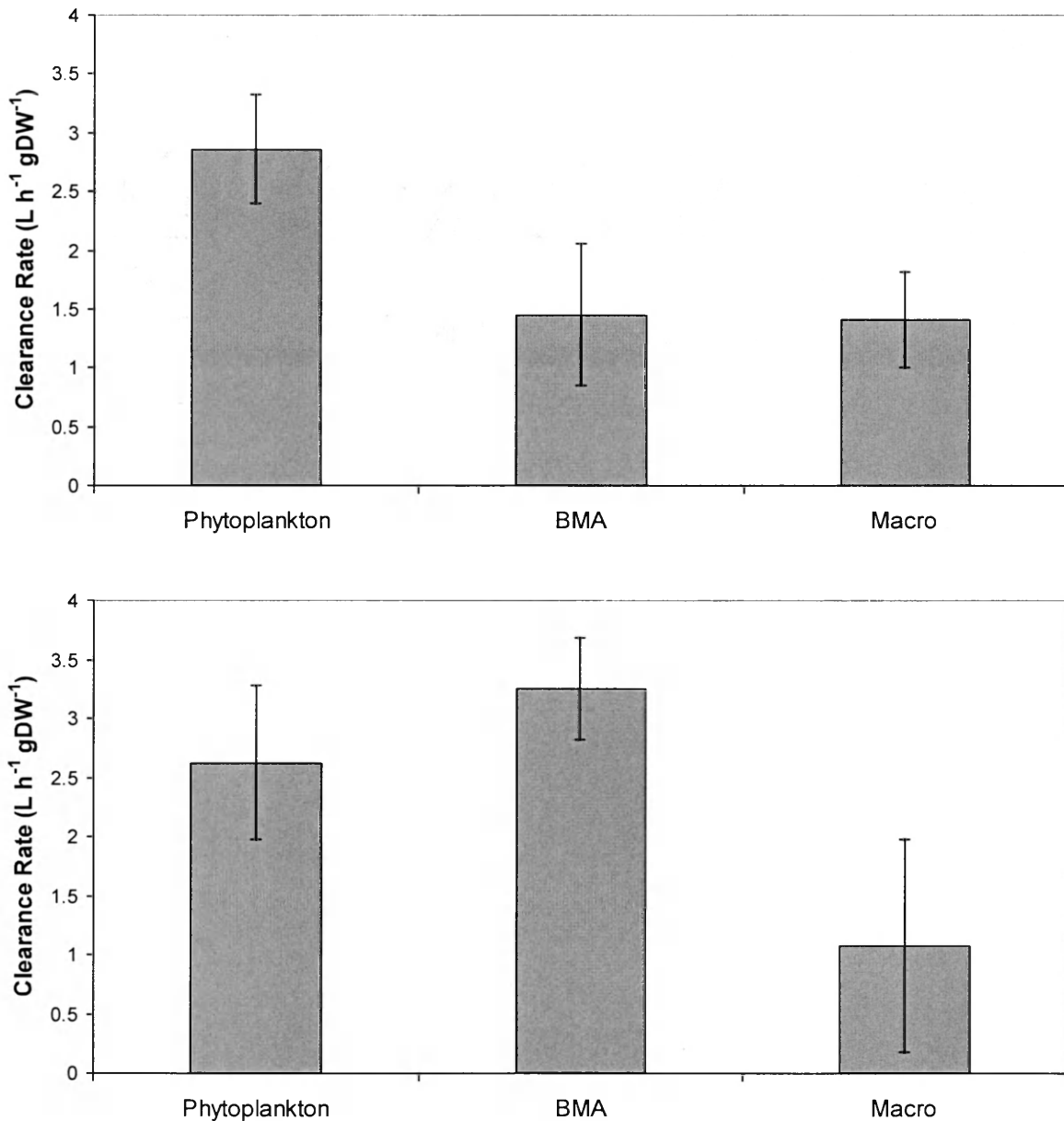

Figure 17. Mass-specific clearance rates (per gram dry tissue weight of clam) in mixed food treatments: mixtures of phytoplankton, BMA, and *Ulva* detritus (top); and mixtures of phytoplankton, BMA, and *Gracilaria* detritus (bottom). Values are mean \pm standard error. No significant differences were found in the *Ulva* mix, and the *Gracilaria* mix could not be analyzed statistically due to low sample size of actively feeding clams.



Absorption Efficiency and Total Suspended Solids in Food Sources

Mean absorption efficiencies ranged between 40 and 80% in both experiments (Figure 18). In experiment 1, total suspended solids (TSS) measured in feeding solutions before addition of clams were very high in BMA treatments (mean 153.3 mg/L) due to fine sediment remaining in BMA solutions. TSS ranged between 16 and 28 mg/L for other treatments. In experiment 2, total suspended solid concentrations were reduced for all treatments, with a mean of 33.5 mg/L for BMA and a range of 12-23 mg/L for other sources. In experiment 1, the only significant difference in absorption efficiencies was that phytoplankton was lower than *Gracilaria* (Kruskal-Wallis, $p = 0.00834$, pairwise Wilcoxon post-hoc $\alpha = 0.05$). Absorption efficiencies were not significantly different in experiment 2 (Kruskal-Wallis, $p = 0.231$).

Relative Food Value Indices

To determine an index of relative food value for the four sources, the method employed by Kreeger and Newell (2001) was used, multiplying mass-specific clearance rates observed in mixed experiments by absorption efficiencies for food sources measured in experiment 2. Mass-specific clearance rates for phytoplankton and BMA were averaged across all feeding clams in both mixed treatments for this calculation. To account for different fractions of clams that fed during clearance rate measurements, a second food value index was calculated by multiplying the above index by the percentage of clams feeding on individual sources in experiments 1 and 2 (Figure 19). It should be noted that these indices do not take into account the nutritive value of food sources after absorption by clams.

Figure 18. Percent absorption efficiencies for individual food sources in experiments 1 (top) and 2 (bottom). Values are mean \pm standard error. Significant differences are indicated for experiment 1 by bars with different letters. No significant differences were found in experiment 2.

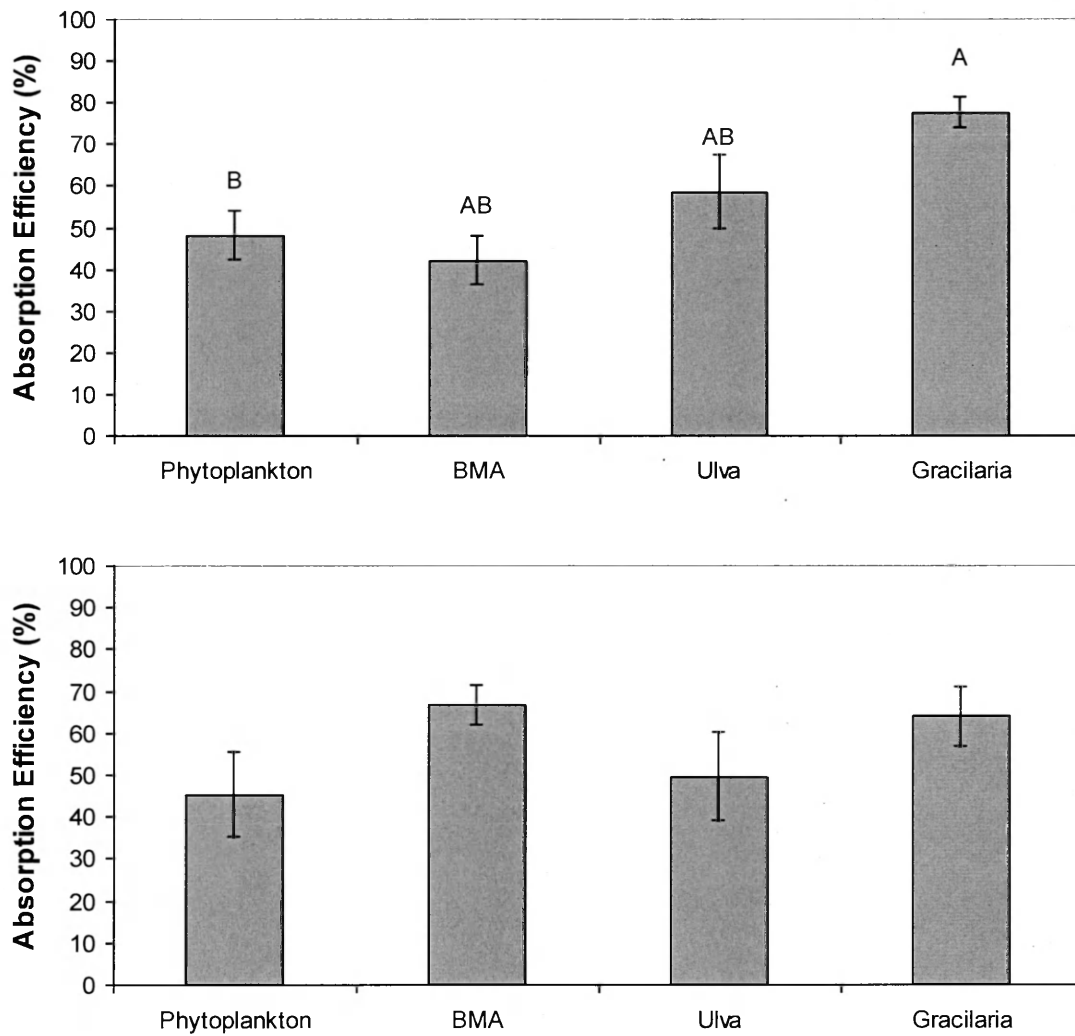
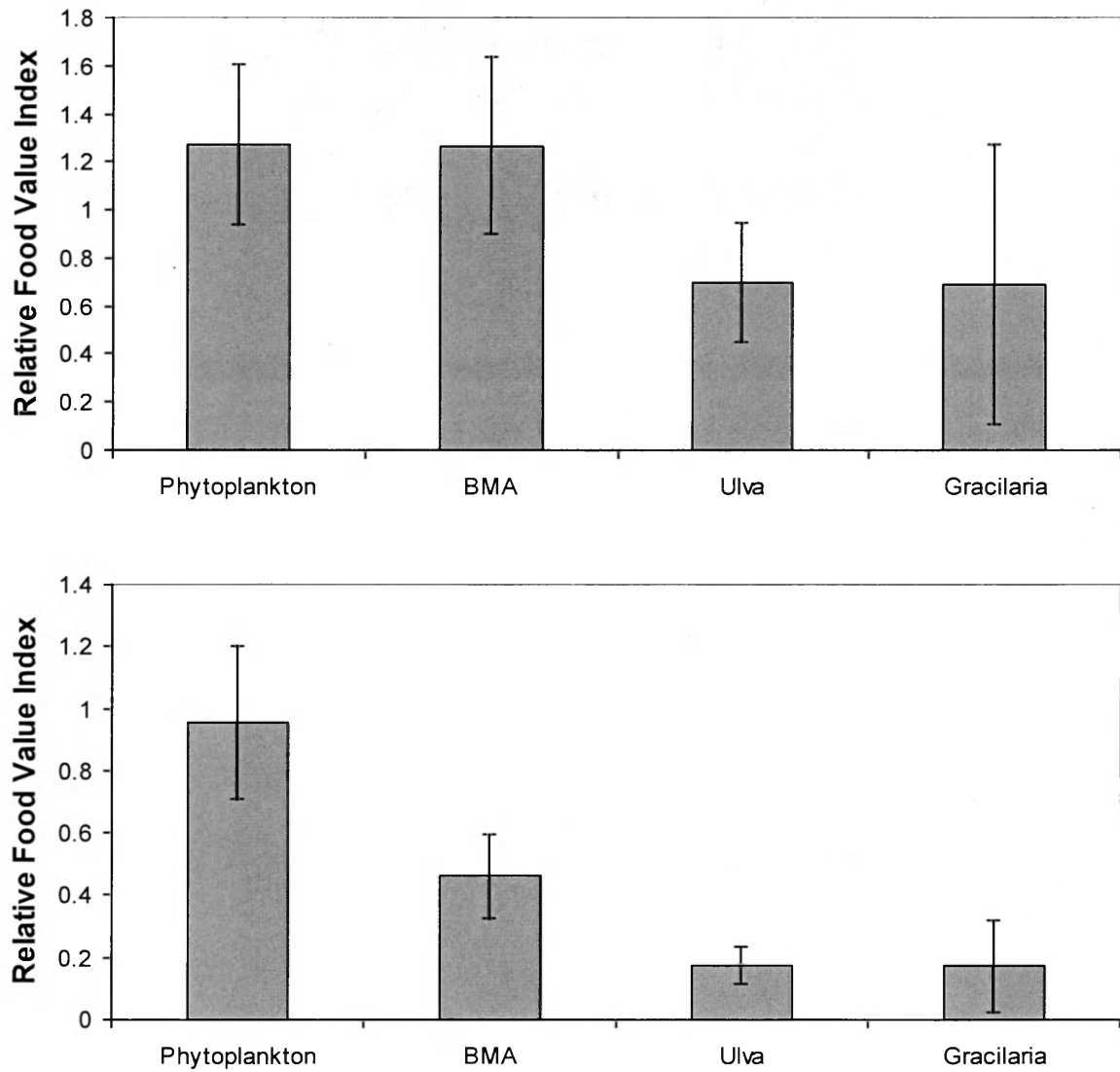

Figure 19. Relative food value indexes calculated for each food source. Top: Mass-specific clearance rate (experiment 3) multiplied by absorption efficiency (experiment 2). Bottom: Index adjusted for percentage of clams observed feeding on food sources during clearance rate measurements (experiments 1 and 2). Error bars indicate standard error propagated from mean clearance rates and absorption efficiencies.



DISCUSSION

This study suggests that resuspended benthic microalgae can be a frequently abundant food source to clams, and that blooms of macroalgae growing on predator exclusion nets provide abundant sources of chlorophyll *a*, phaeophytin, and particulate organic matter under nets where clams feed. Lower levels of diatoms under nets during periods of high macroalgal abundance suggests a potential barrier effect of macroalgae on water flow, which may limit availability of other food sources to clams. Feeding experiment suggest that phytoplankton and BMA are well utilized by clams, and that macroalgal detritus, while less valuable, may still be a viable food source.

I. Food Availability

In cell counts of sediment samples, pennate diatoms were significantly more abundant than centric diatoms in all sampling periods except March 2012, indicating the presence of BMA at the study site (Fryxell, 1983; Smyth, 1995; Marshall, 2009). BMA may not have been abundant during March, as concentrations of pennate diatoms were also low in the water column. With the exception of March, resuspended BMA represented a potentially important food source for clams, as pennate diatom concentrations in the water column were generally comparable to or greater than centric diatom concentrations. The observed high levels of resuspended benthic diatoms relative to phytoplankton are consistent with previous findings in shallow estuaries that resuspended BMA can be a major contributor to water column chlorophyll *a*, particulate organic carbon, and primary production (Roman and

Tenore, 1978; Shaffer and Sullivan, 1988; de Jonge and Beusekom, 1992). Total diatom concentrations in this study were high compared to those observed over mussel beds by Muschenheim and Newell (1992), who measured concentrations of 200 cells/mL over beds while in this study concentrations under nets ranged from about 1,000-2,500 cells/mL. In summer 2011, the lack of significant differences in total diatom concentrations between tidal stages suggests that tidal currents are not the dominant agent of BMA resuspension.

Though used as a proxy for food availability to cultured bivalves (Smaal et al., 2001; Hofmann et al., 2006), no significant relationships were found in this study between potential food sources and chlorophyll *a* levels (0.7 μm fraction) under nets, where clams are actually feeding. In fact, during summer 2011, chlorophyll levels were higher under nets relative to above, while diatom concentrations were lower under nets. This suggests that chlorophyll *a* has the potential to overestimate food availability in aquaculture settings. Particulate organic matter is also used as a proxy for food availability (Carver and Mallet, 1990; Ferreira et al., 1998), but was not significantly related to diatom concentrations under nets in this study. Macroalgal detritus appeared to be the primary contributor to POM under nets, which was significantly related to macroalgal biomass. Furthermore, POM and phaeophytin were both significantly higher under nets relative to above in summer 2011. Thus, the use of POM as a proxy for food availability may yield very different results depending on the presence or absence of macroalgal blooms.

The strong relationships between macroalgal biomass on clam beds and levels of phaeophytin (0.7 and 20 μm fractions) under nets suggest that during times of high abundance, macroalgae are the dominant source of detritus. Macroalgae may also increase the deposition of other sources of detritus under macroalgal mats (Everett, 1994). However,

macroalgal biomass was also strongly correlated with chlorophyll in the 20 μm size fraction. This may indicate a direct contribution of macroalgae to chlorophyll levels, as water samples were dominated by diatoms smaller than 16 μm , such that phytoplankton and BMA would not be major contributors to chlorophyll in this size fraction. Because *M. mercenaria* can filter particles larger than 4 μm with $\sim 100\%$ efficiency (Riisgård, 1988), the strong relationships between macroalgal biomass and 20 μm chlorophyll and phaeophytin indicate that at times of high abundance, macroalgae on clam beds are a source of detritus that can be filtered by clams. More data on conditions during macroalgal blooms would be beneficial in supporting these relationships, as regressions involving macroalgal biomass in this study were likely driven by the high mean macroalgal biomass in June 2011.

Significant differences between diatom concentrations above and below nets coincided with periods of highest macroalgal abundance, while no such differences were observed when macroalgal biomass was low. This indicates a potential barrier effect of macroalgae on clam beds. The marginally significant relationship observed between macroalgal biomass on nets and the difference between diatom concentration above and below nets supports these observations. Although no significant differences in food availability were observed between beds with macroalgae and cleared beds in 2012, there were also no differences observed in food availability above and below un-cleared beds, suggesting that macroalgal densities during this sampling period were too low to cause any barrier effect. Similar experiments comparing food availability in aquaculture areas with higher densities of macroalgae may provide more evidence concerning potential barrier effects. Vertical gradients in food concentration above bivalve aquaculture beds may occur without barriers, as Fr chet te and Bourget (1985) observed depletion of POM 5 cm above

mussel beds compared to 50 cm above beds. However, in the same study current speed and wave energy were shown to reduce this depletion, suggesting that macrophytes that reduce near-bottom water velocity (Judge et al., 2003) may favor depletion. In this study, the fact that differences in diatom concentration were only observed in summer 2011 suggests these differences are not due to clam feeding alone. The species composition of macroalgae may also be important in determining barrier effects, as *Ulva* was negligible in 2012 but was abundant in summer 2011 when differences between diatom concentrations above and below nets were observed. Everett (1994) suggested that the laminar morphology of *Ulva* may create more of a barrier between the sediment and water column than more filamentous forms of macroalgae. Barrier effects are likely to be more pronounced in aquaculture settings with higher densities of macroalgae. In a clam farm in North Carolina, Powers et al. (2007) reported high densities of macroalgae that persisted throughout the year and peaked at about 1,700 g/m². Furthermore, such effects may become more prevalent as macroalgal proliferation may increase in areas experiencing anthropogenic coastal eutrophication (Valiela et al., 1997; Morand and Merceron, 2005; Lapointe and Bedford, 2007).

It is uncertain whether macroalgae affected BMA growth on clam beds, or what fraction of resuspended BMA originated outside of clam beds. The negative relationship between macroalgal abundance and benthic chlorophyll suggests a potential shading effect of macroalgae on BMA growth, although no significant differences were found between benthic chlorophyll levels on clam beds compared to bare areas, even in July 2011. Macroalgae may also serve as habitat for epiphytic diatoms, as pennate diatoms can be found as epiphytes on *Gracilaria* (Aikins and Kikuchi, 2002; Kanaya et al., 2007). Pennate diatom concentrations above nets were significantly higher than those at the bare sediment site in June 2011, though

this may also be a result of suspended diatoms settling in macroalgae due to reduced flow. Furthermore, macroalgal biomass was not related to pennate diatom concentrations above or below nets.

II. Feeding Experiments

In treatments with individual food sources, mass-specific clearance rates of *Ulva* and *Gracilaria* for those clams that fed were similar to or greater than phytoplankton, suggesting that detritus from these species, if available in the appropriate size range, can be filtered readily by clams. However, fewer clams were observed to feed on *Ulva* (25%) and *Gracilaria* (30%) than on phytoplankton (75%) and BMA (35%). In addition, food concentration may have had an effect on differences in feeding observed in the first two experiments, as concentrations were adjusted to minimize TSS rather than to achieve similar organic carbon concentrations as in the third experiment.

In the mixed experiment, clearance rates for macroalgal detritus were lower than other sources. Rates for the *Gracilaria* mixed treatment in particular should be treated with caution, as only 2 out of 10 clams were determined to be feeding. With the exception of BMA in this mixture, clearance rates of each food source in mixed solutions were lower than rates for that food source alone. TSS was high in BMA treatments for experiment 1, which may have contributed to a somewhat lower mean clearance rate, 2.6 L/(h*gDW), compared to the experiment 2 rate of 3.5 L/(h*gDW). Mass-specific clearance rates were compared to previous studies on relationships between *M. mercenaria* clearance rate and dry weight (Table 4). Hibbert (1977) determined clearance rates in flow-through chambers on

particulate organic carbon in natural seawater. Doering and Oviatt (1986) measured clearance rates on total suspended carbon in flow-through chambers, using seston from experimental mesocosms. Riisgård (1988) conducted clearance rate measurements on suspended particles in static containers, using mixtures of natural bacteria and cultured algae, though temperatures were higher (28 °C) than those used in this study. With the exception of BMA, rates calculated from individual food treatments were considerably higher than those predicted by these relationships (Table 4). However, rates calculated from mixed food treatments (as well as BMA rates for individual treatments) were more consistent with relationships based on dry weight determined in these earlier studies. Phytoplankton and BMA rates were similar to those predicted by Hibbert (1977) and Doering and Oviatt (1986). Rates for *Ulva* in mixed experiments were similar to those predicted by Riisgård (1988), and rates for *Gracilaria* were slightly lower. Lower calculated rates for mixed treatments may be due to higher TSS, which likely encouraged pseudofeces production and differential selection and rejection of food sources. In contrast to feeding rates on phytoplankton, which decreased 37% from individual to mixed treatments, feeding rates on *Ulva* and *Gracilaria* decreased 85 and 71%, respectively. This suggests that clams have a lower preference for macroalgal detritus when other food sources are available.

As stated previously, mean clearance rates were calculated only from rates measured for actively feeding clams, and the method of determining feeding clams based on chlorophyll decreases (described above) was fairly consistent with observations of siphon extension during feeding measurements. With the exception of the phytoplankton treatment and the *Ulva* mixture, less than 50% of clams were determined to be feeding in each

Table 4. Relationships between clearance rate and *M. mercenaria* dry weight and experimental conditions from previous studies. F = clearance rate, L = shell length, DW = dry tissue weight, T = temperature. In this study, temperatures ranged between 22.1 and 23.7°C, and clam size ranged from 32-35 mm shell length or 0.23-1.16 g dry tissue weight.

Study	Relationship	Temperature Range	Clam Size Range
Hibbert 1977	$\log_{10}F = 0.892 \log_{10}L - A$ $\log_{10}A = -0.005T + 0.241$	12 – 25 °C	43.4-88.1 mm SL
Doering and Oviatt 1986	$F = 0.033 L^{0.967}$	13.5–21 °C	32-107 mm SL
Riisgård 1988	$F = 1.24 DW^{0.80}$	28 °C	0.017-2.387 g DW

treatment during clearance rate measurements. The percentage of clams feeding on each treatment may in itself be an important consideration with regard to food value. While 75% of clams actively fed on *Chaetoceros*, a genera known to be a high-value food source to *M. mercenaria* (Wikfors et al., 1992), a lower fraction of clams fed on other food sources. Despite high clearance rates on macroalgal detritus in individual treatments, only 25% of clams were feeding in these treatments. While high percentages of clams fed in both the phytoplankton treatment and *Ulva* mixture, only 20% of clams fed on the *Gracilaria* mixture. A similar percentage of feeding clams in treatments with *Gracilaria* alone suggest that this genera may deter clam feeding. *Gracilaria* is known to deter feeding in the snail *Littorina striata* (Granado and Caballero, 1991), and the results of the present study suggest this effect may extend to clams.

Several factors may contribute to the observed reduced feeding on macroalgal detritus. The particle size of macroalgae as it breaks down is important in determining its availability to clam filtration. Particle size was unlikely to affect this study as detrital particle sizes were controlled in experiments such that clearance rates were measured for particles between 1.6 and 63 μm . *M. mercenaria* filters particles above 2 μm with about 50% retention efficiency, and particles above 4 μm with about 100% efficiency (Riisgård, 1988). The maximum size of particles that *M. mercenaria* can efficiently retain is uncertain (Grizzle et al., 2001), though the infaunal bivalve *Cerastoderma edule* is known to efficiently filter particles up to 300 μm in size (Karlsson et al., 2003). Food concentration also affects *M. mercenaria* feeding and clearance rate (Walne, 1970; Grizzle et al., 2001). Food concentrations were kept low in individual treatments to minimize pseudofeces production, and low initial chlorophyll levels were observed in macroalgal treatments. Low food

concentration may account for a low percentage of clams feeding on *Ulva*, as a greater fraction of clams fed on the *Ulva* mixture, which had higher food concentrations. However, the fraction of clams feeding remained consistently low for individual and mixed treatments containing *Gracilaria*. A possible reason macroalgae may lower clam feeding rates even when present with other food sources is the content of secondary metabolites that may deter feeding. These metabolites have been suggested as a reason for reduced feeding on *Gracilaria* by snails (Granado and Caballero, 1991). Some Rhodophyta contain metabolites such as halogenated terpenoids and acetogenins that are known to deter feeding in fish (Granado and Caballero, 1991). Furthermore, variable concentrations of polyphenolic compounds are found in different genera of macroalgae (García-Casal et al., 2009; Rodríguez-Bernaldo de Quirós et al., 2010), including *Gracilaria* (Sreenivasan et al., 2007). High concentrations of polyphenolic compounds have been shown to discourage predation on macroalgae in the order Fucales (Van Alstyne and Paul, 1990), and these compounds have been associated with reduced clearance rates and growth for bivalves fed kelp detritus (Duggins and Eckman, 1997; Levinton et al., 2002). These compounds break down as detritus is decomposed, and the aging of detritus in seawater prior to feeding has been shown to increase its assimilation by bivalves (Cranford and Grant, 1990; Duggins and Eckman, 1997; Levinton et al., 2002). Investigating the effects of detrital age on clam utilization may be important to further understand the value of macroalgae as a food source to clams.

Absorption efficiencies were relatively low compared to measurements for *M. mercenaria* fed cultured microalgae (based on C ingested compared to C in biodeposits) by Tenore and Dunstan (1973), which ranged from 71.2-77.3%. Several factors may cause the Conover method to underestimate absorption efficiency. Some inorganic material may be

absorbed by animals for nutrition, such that food sources with low inorganic content may have a significant portion of inorganic matter absorbed (Conover et al., 1986; Navarro and Thompson, 1994). Bivalves may also excrete organic matter as metabolic byproducts in the digestive tract, organically enriching feces (Hawkins and Bayne, 1984; Navarro and Thompson, 1994). Pseudofeces production may selectively reject inorganic matter and also underestimate efficiency (Cranford and Grant, 1990; Navarro and Thompson 1994; Iglesias et al., 1998). *M. mercenaria* produce negligible pseudofeces under suspended solid concentrations of 10 mg/L, with increasing production at higher concentrations (Bricelj and Malouf, 1984). This likely affected absorption efficiency measurements for BMA in experiment 1, as TSS in BMA solutions was 153.3 compared to 33.5 mg/L in experiment 2, and higher efficiencies were observed in experiment 2. In addition to the BMA treatment, pseudofeces were also observed in some macroalgal detritus treatment replicates. Although TSS was reduced in all treatments for experiment 2 and fewer pseudofeces were observed, absorption efficiencies for macroalgae were slightly higher in the first experiment, suggesting that differences in pseudofeces did not cause underestimation of efficiencies for macroalgal detritus. No significant differences were found between absorption efficiencies for different food sources in experiment 2, suggesting that once ingested these source are utilized similarly by clams.

For the calculation of relative food value indexes, clearance rates from mixed experiments were used, as these are more representative of *in situ* conditions and were consistent with clearance rate relationships in the literature based on dry weight. Absorption efficiencies for these calculations were taken from experiment 2, since lower TSS and pseudofeces production were observed in this experiment. Food value indices suggest that

phytoplankton and BMA are both important food sources to clams. Kreeger and Newell (2001) calculated an index of mass-specific clearance rate multiplied by assimilation efficiency for the mussel *Geukensia demissa*. Their findings suggested that benthic diatoms were the most valuable food source for this species, followed by phytoplankton and cellulosic detritus. When indices were multiplied by the percentage of clams feeding, a relatively higher value for phytoplankton was observed, though macroalgal detritus remains relatively less valuable compared to phytoplankton or BMA. However, it is also important to consider the effect of relative abundances of these food sources in aquaculture environments on their contributions to clam feeding. Macroalgal detritus may still be an important potential contributor to bivalve growth during dense macroalgal blooms, especially if other food sources are depleted. Understanding the role of macroalgal detritus as a food source is important, as trends in coastal eutrophication which may increase the proliferation of macroalgal blooms and enhance the nitrogen content of macroalgae (Valiela et al., 1997; Morand and Merceron, 2005; Lapointe and Bedford, 2007), making it a potentially more valuable food source.

CONCLUSION

Benthic microalgae appeared to be similar in importance to phytoplankton as a food source for cultured clams, both in terms of abundances observed *in situ* and utilization by clams in feeding experiments. Despite their abundance and importance, total diatom concentrations under predator exclusion nets were not correlated in this study with chlorophyll *a* or particulate organic matter, both of which are commonly used proxies for food availability. Particulate organic matter was instead related to macroalgal abundance, which in this study appeared to be a less valuable food source. Macroalgal blooms can potentially affect the availability of food sources by acting as a barrier to water flow and shading benthic microalgae. Despite the lower food value calculated in this study, macroalgal detritus appears to be readily available to cultured clams during blooms, and may still be important to cultured bivalve growth on a seasonal basis. Future modeling studies of cultured bivalve growth and carrying capacity should consider the influence of macroalgal blooms and resuspended benthic microalgae on food availability, as phytoplankton are not necessarily the dominant producer in these environments and indirect measurements of food availability may not account for these different food sources.

LITERATURE CITED

- Adams, C., A. Hodges, and T. Stevens. 2009. Estimating the Economic Impact for the Commercial Hard Clam Culture Industry on the Economy of Florida: Final Report. University of Florida Project #: 00073946. 24 pp.
- Aikins, S., and E. Kikuchi. 2002. Grazing pressure by amphipods on microalgae in Gamo Lagoon, Japan. *Marine Ecology Progress Series* 245: 171-179.
- Arar, E.J., and G.B. Collins. 1997. *In Vitro* Determination of Chlorophyll *a* and Phaeophytin *a* in Marine and Freshwater Algae by Fluorescence. Method 445.0, Revision 1.2. National Exposure Research Laboratory, Office of Research and Development, U.S. Environmental Protection Agency, Cincinnati, OH.
- Ashton, A., A.B. Murray, and O. Arnault. 2001. Formation of coastline features by large-scale instabilities induced by high-angle waves. *Nature* 414: 296-300.
- Bacher, C., P. Duarte, J.G. Ferreira, M. Héral, and O. Raillard. 1998. Assessment and comparison of the Marennes-Oléron Bay (France) and Carlingford Lough (Ireland) carrying capacity with ecosystem models. *Aquatic Ecology* 31: 379-394.
- Bacon, G.S., B.A. MacDonald, and J.E. Ward. 1998. Physiological responses of infaunal (*Mya arenaria*) and epifaunal (*Placopecten magellanicus*) bivalves to variations in the concentration and quality of suspended particles. I. Feeding activity and selection. *Journal of Experimental Marine Biology and Ecology* 219: 105-125.
- Bass, A.E., R.E. Malouf, and S.E. Shumway. 1990. Growth of northern quahogs (*Mercenaria mercenaria* (Linnaeus, 1758)) fed on picoplankton. *Journal of Shellfish Research* 9(2): 299-307.
- Bayne, B. L., and A. J. S. Hawkins. 1992. Ecological and physiological aspects of herbivory in benthic suspension-feeding molluscs, Pages 265-287 in D. M. John, S. J. Hawkins, and J. H. Price, eds. *Plant-Animal Interactions in the Marine Benthos*. Oxford University Press.
- Bisker, R., and M. Castagna. 1985. The effect of various levels of air-supersaturated seawater on *Mercenaria mercenaria* (Linné), *Mulinia lateralis* (Say), and *Mya arenaria* Linné, with reference to gas-bubble disease. *Journal of Shellfish Research* 5(2): 97-102.
- Bricelj, V.M. 1984. Effects of suspended sediments on the feeding physiology and growth of the hard clam, *Mercenaria mercenaria* L. Ph.D. Dissertation, Marine Sciences Research Center, Stony Brook University, Stony Brook, NY, 157 pp.

- Bricelj, V.M., and R.E. Malouf. 1984. Influence of algal and suspended sediment concentrations on the feeding physiology of the hard clam *Mercenaria mercenaria*. *Marine Biology* 84: 155-165.
- Brzezinski, M.A. 1985. The Si:C:N ratio of marine diatoms: Interspecific variability and the effect of some environmental variables. *Journal of Phycology* 21: 347-357.
- Carver, C.E.A., and A.L. Mallet. 1990. Estimating the carrying capacity of a coastal inlet for mussel culture. *Aquaculture* 88(1): 39-53.
- Castagna, M., and P. Chanley. 1973. Salinity tolerance of some marine bivalves from inshore and estuarine environments in Virginia waters on the western mid-Atlantic coast. *Malacologia* 12(1): 47-96.
- Castagna, M. 1984. Methods of growing *Mercenaria mercenaria* from postlarval- to preferred-size seed for field planting. *Aquaculture* 39: 355-359.
- Castagna, M. 2001. Aquaculture of the Hard Clam, *Mercenaria mercenaria*, Pages 675-699 in J. N. Kraeuter, and M. Castagna, eds. *Biology of the hard clam*. Amsterdam, Elsevier.
- Charles, F. 1993. Utilization of fresh detritus derived from *Cystoseira mediterranea* and *Posidonia oceanica* by the deposit-feeding bivalve *Abra ovata*. *Journal of Experimental Marine Biology and Ecology* 174: 43-64.
- Condon, E. 2005. Physiological Ecology of the Cultured Hard Clam, *Mercenaria mercenaria*: A Case Study in Cherrystone Inlet, Virginia. M.S. Thesis, Virginia Institute of Marine Science, Gloucester Point, VA, 195 pp.
- Conover, R.J. 1966. Assimilation of organic matter by zooplankton. *Limnology and Oceanography* 11: 338-345.
- Conover, R.J., R. Durvasula, S. Roy, and R. Wang. 1986. Probable loss of chlorophyll-derived pigments during passage through the gut of zooplankton, and some of the consequences. *Limnology and Oceanography* 31(4): 878-887.
- Coughlan, J. 1969. The estimation of filtering rate from the clearance of suspensions. *Marine Biology* 2: 356-358.
- Cranford, P.J., and J. Grant. 1990. Particle clearance and absorption of phytoplankton and detritus by the sea scallop *Placopecten magellanicus* (Gmelin). *Journal of Experimental Marine Biology and Ecology* 137: 105-121.
- De Jonge, V.N., and J.E.E. van Beusekom. 1992. Contribution of resuspended microphytobenthos to total phytoplankton in the Ems estuary and its possible role for grazers. *Netherlands Journal of Sea Research* 30: 91-105.

- De Jonge, V.N., and J.E.E. van Beusekom. 1995. Wind- and tide-induced resuspension of sediment and microphytobenthos from tidal flats in the Ems estuary. *Limnology and Oceanography* 40(4): 766-778.
- Doering, P.H., and C.A. Oviatt. 1986. Application of filtration rate models to field populations of bivalves: an assessment using experimental mesocosms. *Marine Ecology Progress Series* 31:265-275.
- Dowd, M. 1997. On predicting the growth of cultured bivalves. *Ecological Modelling* 104: 113-131.
- Duggins, D.O., and J.E. Eckman. 1997. Is kelp detritus a good food for suspension feeders? Effects of kelp species, age and secondary metabolites. *Marine Biology* 128: 489-495.
- Eble, A.F. 2001. Anatomy and Histology of *Mercenaria mercenaria*, Pages 117-220 in J.N. Kraeuter, and M. Castagna, eds. *Biology of the hard clam*. Amsterdam, Elsevier.
- Everett, R.A. 1994. Macroalgae in marine soft-sediment communities: effects on benthic faunal assemblages. *Journal of Experimental Marine Biology and Ecology* 175: 253-274.
- Eversole, A.G. 2001. Reproduction in *Mercenaria mercenaria*, Pages 221-260 in J. N. Kraeuter, and M. Castagna, eds. *Biology of the hard clam*. Amsterdam, Elsevier.
- FAO. 2012. *The State of the World Fisheries and Aquaculture 2012*. Food and Agricultural Organization of the United Nations. Rome, 209 pp.
- Ferreira, J.G., P. Duarte, and B. Ball. 1998. Trophic capacity of Carlingford Lough for oyster culture – analysis by ecological modeling. *Aquatic Ecology* 31: 361-378.
- Findlay, S., and K. Tenore. 1982. Nitrogen Source for a Detritivore: Detritus Substrate Versus Associated Microbes. *Science* 218(4570): 371-373.
- Flynn, K.J. 1990. The determination of nitrogen status in microalgae. *Marine Ecology Progress Series* 61: 297-307.
- Fréchette, M., and E. Bourget. 1985. Energy Flow Between the Pelagic and Benthic Zones: Factors Controlling Particulate Organic Matter Available to an Intertidal Mussel Bed. *Canadian Journal of Fisheries and Aquatic Sciences* 42: 1158-1165.
- Fryxell, G.A. 1983. New evolutionary patterns in diatoms. *BioScience* 33(2): 92-98.
- García-Casal, M.N., J. Ramírez, I. Leets, A.C. Pereira, and M.F. Quiroga. 2009. Antioxidant capacity, polyphenol content and iron bioavailability from algae (*Ulva* sp., *Sargassum* sp. and *Porphyra* sp.) in human subjects. *British Journal of Nutrition* 101(1): 79-85.

- Grabowski, J.H., S.P. Powers, and M. Hooper. 2000. Balancing tradeoffs between predator protection and associated growth penalties in aquaculture of northern quahogs, *Mercenaria mercenaria* (Linnaeus, 1758): A comparison of two common grow-out methods. *Journal of Shellfish Research* 19(2): 957-962.
- Granado, I., and P. Caballero. 1991. Feeding preferences by *Littorina striata* King and Broderip on different algal species. *Scientia Marina* 55(4): 577-581.
- Grant, J., J. Stenton-Dozey, P. Montiero, G. Pitcher, and K. Heasman. 1998. *Journal of Shellfish Research* 17(1): 41-49.
- Greenfield, D.I., D.J. Lonsdale, R.M. Cerrato, and G.R. Lopez. 2004. Effects of background concentrations of *Aureococcus anophagefferens* (brown tide) on growth and feeding in the bivalve *Mercenaria mercenaria*. *Marine Ecology Progress Series* 274: 171-181.
- Greenfield, D.I., D.J. Lonsdale, and R.M. Cerrato. 2005. Linking Phytoplankton Community Composition with Juvenile-Phase Growth in the Northern Quahog *Mercenaria mercenaria* (L.). *Estuaries* 28: 241-251.
- Grizzle, R.E., V.M. Bricelj, and S.E. Shumway. 2001. Physiological Ecology of *Mercenaria mercenaria*, Pages 305-371 in J.N. Kraeuter, and M. Castagna, eds. *Biology of the hard clam*. Amsterdam, Elsevier.
- Haas, L.W., 1982. Improved epifluorescence microscopy for observing planktonic microorganisms. *Annales de l'Institut Océanographique de Monaco*. (Paris) 58: 262-266 (Suppl.).
- Hamwi, A. 1969. Oxygen consumption and pumping rate of the hard clam *Mercenaria mercenaria* L. Ph.D. Dissertation, Rutgers University, New Brunswick, NJ, 177 pp.
- Hardison, A.K. 2009. Interactions between macroalgae and the sediment microbial community: Nutrient cycling within shallow coastal bays. Ph.D. Dissertation, Virginia Institute of Marine Science, Gloucester Point, VA, 285 pp.
- Harte, M.E. 2001. Systematics and Taxonomy, Pages 3-43 in J.N. Kraeuter, and M. Castagna, eds. *Biology of the hard clam*. Amsterdam, Elsevier.
- Haven, D.S., and R. Morales-Alamo. 1966. Aspects of biodeposition by oysters and other invertebrate filter feeders. *Limnology and Oceanography* 11(4): 487-498.
- Hawkins, A.J.S., and B.L. Bayne. 1984. Seasonal variation in the balance between physiological mechanisms of feeding and digestion in *Mytilus edulis* (Bivalvia: Mollusca). *Marine Biology* 82: 233-240.

- Heip, C.H.R., N.K. Goosen, P.M.J.Herman, J. Kromkamp, J.J. Middelburg, and K. Soetaert. 1995. Production and consumption of biological particles in temperate tidal estuaries. *Oceanography and Marine Biology: An Annual Review* 33: 1-149.
- Hibbert, C.J. 1977. Energy relations of the bivalve *Mercenaria mercenaria* on an intertidal mudflat. *Marine Biology* 44: 77-84.
- Higgins, S.N., R.E. Hecky, and S.J. Guildford. 2008. The collapse of benthic macroalgal blooms in response to self-shading. *Freshwater Biology* 53: 2557-2572.
- Hillebrand, H., and U. Sommer. 1997. Response of epilithic microphytobenthos of the Western Baltic Sea to *in situ* experiments with nutrient enrichment. *Marine Ecology Progress Series* 160: 35-46.
- Hillebrand, H., and U. Sommer. 1999. The nutrient stoichiometry of benthic macroalgal growth: Redfield proportions are optimal. *Limnology and Oceanography* 44(2): 440-446.
- Hofmann, E.E., J.M. Klinck, J.N. Kraeuter, E.N. Powell, R.E. Grizzle, S.C. Buckner, and V.M. Bricelj. 2006. A population dynamics model of the hard clam, *Mercenaria mercenaria*: development of the age- and length-frequency structure of the population. *Journal of Shellfish Research*, 25(2): 417-444.
- Huang, C., H. Lin, T. Huang, H. Su, and J. Hung. 2008. Responses of phytoplankton and periphyton to system-scale removal of oyster-culture racks from a eutrophic tropical lagoon. *Marine Ecology Progress Series* 358: 1-12.
- Hyun, K., I. Pang, J.M. Klinck, K. Choi, J. Lee, E.N. Powell, E.E. Hoffmann, and E.A. Bochenek. 2001. The effect of food composition on Pacific oyster *Crassostrea gigas* (Thunberg) growth in Korea: a modeling study. *Aquaculture* 199: 41-62.
- Iglesias, J.I.P., M.B. Urrutia, E. Navarro, and I. Ibarrola. 1998. Measuring feeding and absorption in suspension-feeding bivalves: an appraisal of the biodeposition method. *Journal of Experimental Marine Biology and Ecology* 219: 71-86.
- Judge, M.L., L.D. Coen, and K.L. Heck, Jr. 1993. Does *Mercenaria mercenaria* encounter elevated food levels in seagrass beds? Results from a novel technique to collect suspended food resources. *Marine Ecology Progress Series* 92: 141-150.
- Kanaya, G., S. Takagi, E. Nobata, and E. Kikuchi. 2007. Spatial dietary shift of macrozoobenthos in a brackish lagoon revealed by carbon and nitrogen stable isotope ratios. *Marine Ecology Progress Series* 345: 117:127.
- Karlsson, Ö., P.R. Jonsson, and A.I. Larsson. 2003. Do large seston particles contribute to the diet of the bivalve *Cerastoderma edule*? *Marine Ecology Progress Series* 261: 161-173.

- Kjørboe, T., F. Møhlenberg, and O. Nøhr. 1980. Feeding, particle selection and carbon absorption in *Mytilus edulis* in different mixtures of algae and resuspended bottom material. *Ophelia* 19(2): 193-205.
- Kraeuter, J.N., and M. Castagna. 1977. An analysis of gravel, pens, crab traps and current baffles as protection for juvenile hard clams (*Mercenaria mercenaria*). Proceedings of the World Mariculture Society, Eight Annual Meeting: 581-592.
- Kreeger, D.A., and R.I.E. Newell. 2001. Seasonal utilization of different seston carbon sources by the ribbed mussel, *Geukensia demissa* (Dillwyn) in a mid-Atlantic salt marsh. *Journal of Experimental Marine Biology and Ecology* 260: 71-91.
- Langdon, C.J., and R.I.E. Newell. 1990. Utilization of detritus and bacteria as food sources by two bivalve suspension-feeders, the oyster *Crassostrea virginica* and the mussel *Geukensia demissa*. *Marine Ecology Progress Series* 58: 299-310.
- Lapointe, B.E., and B.J. Bedford. 2007. Drift rhodophyte blooms emerge in Lee County, Florida, USA: Evidence of escalating coastal eutrophication. *Harmful Algae* 6: 421-437.
- Leduc, D., P.K. Probert, R.D. Frew, and C.L. Hurd. 2006. Macroinvertebrate diet in intertidal seagrass and sandflat communities: A study using C, N, and S stable isotopes. *New Zealand Journal of Marine and Freshwater Research* 40(4): 615-629.
- Levinton, J.S., J.E. Ward, and S.E. Shumway. 2002. Feeding responses of the bivalves *Crassostrea gigas* and *Mytilus trossulus* to chemical composition of fresh and aged kelp detritus. *Marine Biology* 141: 367-376.
- Loosanoff, V.L. 1939. Effect of temperature upon shell movements of clams, *Venus mercenaria* (L.). *Biological Bulletin* 76: 171-182.
- Lorenzen, C. 1967. Determination of chlorophyll and phaeopigments: spectrophotometric equations. *Limnology and Oceanography* 12: 343-346.
- Lucas, A., and P.G. Beninger. 1985. The use of physiological condition indices in marine bivalve aquaculture. *Aquaculture* 44: 187-200.
- Lucas, C.H., C. Benham, and P.M. Holligan. 2001. Benthic-pelagic exchange of microalgae at a tidal flat. 2. Taxonomic analysis. *Marine Ecology Progress Series* 45: 217-223.
- Luckenbach, M.W., and H.V. Wang. 2004. Linking watershed loading and basin-level carrying capacity models to evaluate the effects of land use on primary production and shellfish aquaculture. *Bulletin of Fisheries Research Agency Supplement No. 1*: 123-132.

- Malouf, R., R. Keck, D. Maurer, and C. Epifanio. 1972. Occurrence of Gas-Bubble Disease in Three Species of Bivalve Molluscs. *Journal Fisheries Research Board of Canada* 29(5): 588-589.
- Marinov, D., L. Galbiati, G. Giordani, P. Viaroli, A. Norro, S. Bencivelli, and J.M. Zaldívar. 2007. An integrated modelling approach for the management of clam farming in coastal lagoons. *Aquaculture* 269: 306-320.
- Marshall, H.G. 2009. Phytoplankton of the York River. *Journal of Coastal Research, Special Issue* 57: 59-65.
- McGlathery, K.J., D. Krause-Jensen, S. Rysgaard, and P.B. Christensen. 1997. Patterns of ammonium uptake within dense mats of the filamentous macroalga *Chaetomorpha linum*. *Aquatic Botany* 59: 99-115.
- Moore, H.J. 1971. The structure of the latero-frontal cirri on the gills of certain lamellibranch mollusks and their role in suspension feeding. *Marine Biology* 11: 23-27.
- Morand, P., and M. Merceron. 2005. Macroalgal population and sustainability. *Journal of Coastal Research* 21(5): 1009-1020.
- Murray, T.J., and J.E. Kirkley. 2005. Economic Activity Associated with Clam Aquaculture in Virginia – 2004. Virginia Institute of Marine Science, Marine Resource Report No. 2005-5, 21 pp.
- Murray, T.J., and K. Hudson. 2012. Virginia Shellfish Aquaculture Situation and Outlook Report: Results of 2011 Virginia Shellfish Aquaculture Crop Reporting Survey. Virginia Institute of Marine Science, Marine Resource Report No. 2012-04, 20 pp.
- Muschenheim, D.K., and C.R. Newell. 1992. Utilization of seston flux over a mussel bed. *Marine Ecology Progress Series* 85:131-136.
- Navarro, J.M., and R.J. Thompson. 1994. Comparison and evaluation of different techniques for measuring absorption efficiency in suspension feeders. *Limnology and Oceanography* 39(1): 159-164.
- Neori, A., I. Cohen, and H. Gordin. 1991. *Ulva lactuca* Biofilters for Marine Fishpond Effluents. II. Growth Rate, Yield and C:N Ratio. *Botanica Marina* 34: 483-489.
- Newell, R.I.E., and E.W. Koch. 2004. Modeling Seagrass Density and Distribution in Response to Changes in Turbidity Stemming from Bivalve Filtration and Seagrass Sediment Stabilization. *Estuaries* 27(5): 793-806.

- Pérez-Mayorga, D.M., L.B. Ladah, J.A. Zertuche-González, J.J. Leichter, A.E. Filonov, and M.F. Lavín. 2011. Nitrogen uptake and growth by the opportunistic macroalga *Ulva lactuca* (Linnaeus) during the internal tide. *Journal of Experimental Marine Biology and Ecology* 406: 108-115.
- Peterson, C.H. 1982. The importance of predation and intra- and interspecific competition in the population biology of two infaunal suspension-feeding bivalves, *Protothaca staminea* and *Chione undatella*. *Ecological Monographs* 52(4): 437-475.
- Peterson, C.H., and R. Black. 1987. Resource depletion by active suspension feeders on tidal flats: Influence of local density and tidal elevation. *Limnology and Oceanography* 32(1): 143-166.
- Powell, E.N., E.E. Hofmann, J.M. Klinck, and S.M. Ray. 1992. Modeling oyster populations I. A commentary on filtration rate. Is faster always better? *Journal of Shellfish Research* 11: 387-416.
- Powers, M.J., C.H. Peterson, H.C. Summerson, and S.P. Powers. 2007. Macroalgal growth on bivalves aquaculture netting enhances nursery habitat for mobile invertebrates and juvenile fishes. *Marine Ecology Progress Series* 339: 109-122.
- Reay, W.G., D.L. Gallagher, and G.M. Simmons Jr. 1995. Sediment-water column oxygen and nutrient fluxes in nearshore environments of the lower Delmarva Peninsula, USA. *Marine Ecology Progress Series* 118: 215-227.
- Rice, M.A., and G.C. Stephens. 1988. Influx, net flux and transepithelial flux of aminoacids in the hardshell clam *Mercenaria mercenaria* (Linné): Influence of salinity. *Comparative Biochemistry and Physiology* 89A(4): 631-636.
- Riera, P. 2010. Trophic plasticity of the gastropod *Hydrobia ulvae* within an intertidal bay (Roscoff, France): A stable isotope evidence. *Journal of Sea Research*: 63: 78-83.
- Riera, P., L.J. Stal, J. Nieuwenhuize, P. Richard, G. Blanchard, and F. Gentil. 1999. Determination of food sources for benthic invertebrates in a salt marsh (Aiguillon Bay, France) by carbon and nitrogen stable isotopes: importance of locally produced sources. *Marine Ecology Progress Series* 187: 301-307.
- Riisgård, H.U. 1988. Efficiency of particle retention and filtration rate in 6 species of Northeast American bivalves. *Marine Ecology Progress Series* 45: 217-223.
- Rodríguez-Bernaldo de Quirós, A.R., M.A. Lage-Yusty, and J. López-Hernández. 2010. Determination of phenolic compounds in macroalgae for human consumption. *Food Chemistry* 121: 634-638.

- Roman, M.R., and K.R. Tenore. 1978. Tidal resuspension in Buzzards Bay, Massachusetts. I. Seasonal changes in the resuspension of organic carbon and chlorophyll *a*. *Estuarine and Coastal Marine Science* 6: 37-46.
- Schaal, G., P. Riera, and C. Leroux. 2008. Trophic coupling between two adjacent benthic food webs within a man-made intertidal area: A stable isotopes evidence. *Estuarine, Coastal and Shelf Science* 77: 523-534.
- Scholten, H., and A.C. Smaal. 1998. Responses of *Mytilus edulis* L. to varying food concentrations: testing EMMY, an ecophysiological model. *Journal of Experimental Marine Biology and Ecology* 219: 217-239.
- Shaffer, G.P., and M.J. Sullivan. 1988. Water column productivity attributable to displaced benthic diatoms in well-mixed shallow estuaries. *Journal of Phycology* 24: 132-140.
- Shoaf, W.T., and B.W. Lium. 1976. Improved extraction of chlorophyll *a* and *b* from algae using dimethyl sulfoxide. *Limnology and Oceanography* 21: 926-928.
- Shumway, S.E., T.L. Cucci, R.C. Newell, and C.M. Yentsch. 1985. Particle selection, ingestion, and absorption in filter-feeding bivalves. *Journal of Experimental Marine Biology and Ecology* 91: 77-92.
- Smaal, A.C., T.C. Prins, N. Dankers, and B. Ball. 1998. Minimum requirements for modeling bivalve carrying capacity. *Aquatic Ecology* 31: 423-428.
- Smaal, A.C., M. van Stralen, and E. Schuiling. 2001. The interaction between shellfish culture and ecosystem processes. *Canadian Journal of Fisheries and Aquatic Sciences* 58(5): 991-1002.
- Smaal, A.C., and W. Zurburg. 1997. The uptake and release of suspended and dissolved material by oysters and mussels in Marennes-Oléron Bay. *Aquatic Living Resources* 10: 23-30.
- Soniat, T.M., E.N. Powell, E.E. Hofmann, and J.M. Klinck. 1998. Understanding the success and failure of oyster populations: The importance of sampled variables and sample timing. *Journal of Shellfish Research* 17(4): 1149-1165.
- SRAC. 2005. Biology and Culture of the Hard Clam (*Mercenaria mercenaria*). Southern Regional Aquaculture Center. SRAC Publication No. 433. 6 pp.
- Sreenivasan, S., D. Ibrahim, and M.J.N.M. Kassim. 2007. Free radical Scavenging Activity and Total Phenolic Compounds of *Gracilaria changii*. *International Journal of Natural and Engineering Sciences* 1(3): 115-117.

- Summerson, H.C., C.H. Peterson, and M. Hooper. 1995. Aquaculture production of northern quahogs, *Mercenaria mercenaria* (Linnaeus, 1758): High water temperatures in the nursery and growth penalties of predator control by gravel. *Journal of Shellfish Research* 14(1): 25-31.
- Sundbäck, K., and A. Miles. 2000. Balance between denitrification and macroalgal incorporation of nitrogen in microtidal sediments, NE Kattegat. *Aquatic Microbial Ecology* 22: 291-300.
- Smyth, J.C. 1955. A study of benthic diatoms of Loch Sween (Argyll). *Journal of Ecology* 43(1): 149-171.
- Tenore, K.R., and W.M. Dunstan. 1973. Comparison of biodeposition of three bivalves at different food levels. *Marine Biology* 21:190-195.
- Turner, J.T., P.A. Tester, and R.L. Ferguson. 1988. The marine cladoceran *Penilia avirostris* and the “microbial loop” of pelagic food webs. *Limnology and Oceanography* 33(2): 245-255.
- Valiela, I., K. Foreman, M. LaMontagne, D. Hersh, J. Costa, C. D’Avanzo, and M. Babione. 1992. Couplings of Watersheds and Coastal Waters: Sources and Consequences of Nutrient Enrichment in Waquoit Bay, Massachusetts. *Estuaries* 15(4): 443-457.
- Valiela, I., J. McClelland, J. Hauxwell, P.J. Behr, D. Hersh, and K. Foreman. 1997. Macroalgal blooms in shallow estuaries: controls and ecophysiological and ecosystem consequences. *Limnology and Oceanography* 42(5): 1105-1118.
- Van Alstyne, K.L., and V.J. Paul. 1990. The Biogeography of Polyphenolic Compounds in Marine Macroalgae: Temperate Brown Algal Defenses Deter Feeding by Tropical Herbivorous Fishes. *Oecologia* 84(2): 158-163.
- Walne, P.R. 1970. Studies on the food value of nineteen genera of algae to juvenile bivalves of the genera *Ostrea*, *Crassostrea*, *Mercenaria* and *Mytilus*. *Fishery Investigations, Series II, Vol. 26*, 62 pp.
- Ward, J.E., B.A. MacDonald, R.J. Thompson, and P.G. Beninger. 1993. Mechanisms of suspension feeding in bivalves: Resolution of current controversies by means of endoscopy. *Limnology and Oceanography* 38(2): 265-272.
- Weiss, M.B., P.B. Curran, B.J. Peterson, and C.J. Gobler. 2007. The influence of plankton composition and water quality on hard clam (*Mercenaria mercenaria* L.) populations across Long Island’s south shore lagoon estuaries (New York, USA). *Journal of Experimental Marine Biology and Ecology* 345: 12-25.

- Wikfors, G.H., G.E. Ferris, and B.C. Smith. 1992. The relationship between gross biochemical composition of cultured algal foods and growth of the hard clam, *Mercenaria mercenaria* (L.). *Aquaculture* 108: 135-154.
- Wildish, D., and D. Kristmanson. 1997. *Benthic suspension feeders and flow*. Cambridge University Press, 409 pp.
- Wiseman, H.M. 2010. Quantifying the Ecosystem Role of a Suspension and a Facultative Deposit Feeding Bivalve in the New River Estuary, NC, with Responses to Changes in Nutrient and Sediment Inputs. M.S. Thesis, Virginia Institute of Marine Science, Gloucester Point, VA, 151 pp.
- Yokoyama, H., T. Sakami, and Y. Ishihi. 2009. Food sources of benthic animals on intertidal and subtidal bottoms in inner Ariake Sound, southern Japan, determined by stable isotopes. *Estuarine, Coastal and Shelf Science* 82: 243-253.
- Zarnoch, C.B., and M.P. Schreiber. 2008. Influence of temperature and food availability on the biochemical composition and mortality of juvenile *Mercenaria mercenaria* (L.) during the over-winter period. *Aquaculture* 274: 281-291.

VITA

Richard Garrik Secrist

Born in Knoxville, Tennessee, 4 March 1987. Earned a B.A. in biology at Maryville College in 2009. Entered the masters' program at the Virginia Institute of Marine Science, The College of William and Mary in 2010.