



W&M ScholarWorks

Undergraduate Honors Theses

Theses, Dissertations, & Master Projects

5-2018

The Test-Retest Reliability of ERP Components as Assessed by the Brief Neurometric Battery

James D. Cole

The College of William and Mary

Paul Kieffaber

The College of William and Mary

Follow this and additional works at: <https://scholarworks.wm.edu/honorsthesis>

 Part of the [Cognitive Neuroscience Commons](#), [Diagnosis Commons](#), [Equipment and Supplies Commons](#), [Other Analytical, Diagnostic and Therapeutic Techniques and Equipment Commons](#), and the [Vital and Health Statistics Commons](#)

Recommended Citation

Cole, James D. and Kieffaber, Paul, "The Test-Retest Reliability of ERP Components as Assessed by the Brief Neurometric Battery" (2018). *Undergraduate Honors Theses*. Paper 1243.

<https://scholarworks.wm.edu/honorsthesis/1243>

This Honors Thesis is brought to you for free and open access by the Theses, Dissertations, & Master Projects at W&M ScholarWorks. It has been accepted for inclusion in Undergraduate Honors Theses by an authorized administrator of W&M ScholarWorks. For more information, please contact scholarworks@wm.edu.

The Test-Retest Reliability of ERP Components as Assessed by the Brief Neurometric Battery

James D. Cole

Paul Kieffaber

5/1/2018

Abstract

Electroencephalography (EEG) has been a crucial component of neuropsychological research for nearly a century. Recent applications of the EEG recordings in a clinical setting have demonstrated a range of diagnostic and prognostic uses. Certain changes in event-related potentials (ERP) have been linked to the effects of different neurological conditions and can be accurately used to determine the severity of those conditions. However, in order to assess the stability of these ERP recordings over an extended period of time, one must first establish their statistical test-retest reliability. Using a novel Brief Neurometric Battery we assessed seven different ERP components in twenty college-age subjects. After our initial recordings we then repeated the assessment roughly a week afterward. Both sets of data were then analyzed to determine the relative consistency of the ERP recordings. Out of the seven, only one ERP component, the frequency mismatch negativity, was shown to have significantly reliable measure across trials. Further trials with slight experimental alterations will be required to further assess the test-retest reliability of the remaining ERP components.

Introduction

The technique of electroencephalography (EEG) has been a long standing method of measuring brain activity in both clinical and cognitive neuroscience. By utilizing EEG, investigators may study the functions of the human brain in-vivo as it is reflected in the electrical activity that can be recorded at the scalp. EEG proves advantageous in numerous fields, as it can be used to clarify the relationship between external stimuli, sensory and perceptual processing, and the factors that may alter these brain activities. EEG is traditionally used to understand the average brain activation to external stimuli, namely through spectral analysis and event related potentials (ERP), with its primary advantages over other imaging techniques being that it is noninvasive and possesses high temporal resolution (Swartz, 1998).

Origins of the EEG in Psychological Research

The first demonstration of the use of EEG was performed by the German psychiatrist Hans Berger in 1924. While his work served as the first example of an electricity based neural recording, what we now recognize as EEG would not be developed until the 1920's as the result of work performed by Richard Caton, Vladimir Neminsky, and Adolf Beck. Decades of focus on the electrical components of neural function established a tradition of electrophysiological methods that would revolutionize modern neuroscience.

It wasn't until the 1930's that EEG was recognized as a useful clinical tool. Initially used to study the physiological effects of seizures and epileptic activity, the EEG was found to possess unique waveforms that could be used to model epileptiform spikes (Swartz, 1998). These spikes were first discovered by Lowenback and Fisher in 1934; a finding which launched a rise in epilepsy centered EEG research. This increased focus led to the founding of the American EEG

Society in 1947. EEG's increased popularity allowed researchers to better understand the fundamental causes and mechanism of epileptic seizures, as demonstrated by Gibbs and Davis' identification of the pattern characterizing absence seizures (Swartz, 1998).

Since then, the application of EEG in clinical and cognitive neuroscience has expanded widely. While the first EEG required a crude array of silver-bromide sensitive photographic recorders, needle electrodes, and simple galvanometers, the demand for accurate changes in voltage led to Albert Grass' 1935 three-channel vacuum tube amplifier system. This device vastly improved upon earlier models, allowing for more temporally precise measurements necessary to understand the quick propagation of epileptic activity. Grass' design, known as "Model 1," likewise sparked interest in other neurophysiological applications. Alfred Fessard began to use the EEG to study the conditioning of alpha rhythms (Jackson, 2014). His work brought EEG to the forefront of popular neurological and psychological research methods after the Second World War. From then on, it was increasingly used for other areas of clinical research including sleep studies, encephalopathy prognostics, and spatially focused disorders such as strokes or neuroblastomas (Swartz, 1998; Jackson, 2014) .

In the later part of the 20th century, application of EEG in neurophysiological research was further aided by a growing interest in cybernetics and its relationship with physical electrodynamics. Neurologist and engineer William Grey Walter revolutionized the EEG by developing his topographical system of analysis. This new method allows for higher spatial resolution which can be interpolated with the temporal algorithms to provide a more sensible visual representation of localized brain activity. This technique has influenced neural mapping and led to further popular use during the 1980's neuroscientific renaissance (Beres, 2017).

Advantages of EEG

In recent years, EEG has been utilized for a wide array of both clinical and academic research. While some have questioned its efficacy in relation to other imaging techniques such as MRI, fMRI, CAT scans, and MEG, many continue to employ EEG due to several key advantages. First, EEG's relatively simple, non-invasive setup allows for quick measurements of a subject's neural activity without seriously compromising a subject's physical well-being. EEG utilizes comparatively affordable hardware which has proven to be far more mobile and accessible than many other techniques. As previously mentioned, EEG also has immense temporal resolution reaching upwards of 21,000 Hz, an ability that has been critical to time-sensitive cognitive research over the last three decades (Swartz, 1998). Many subjects likewise prefer undergoing EEG tests over other imaging methods as its instruments and setting are far less agitating. Unlike fMRI and other similar instruments, EEG does not aggravate patients suffering from claustrophobia, sensitivity to sound, or those unable to remain still for extended periods of time.

EEG also provides other advantageous measures for cognitive research that are not clearly distinguishable in other imaging methods. Unlike other methods, EEG can accurately determine specific groups of signals as they result from elicited responses or stimuli. Meanwhile, techniques such as MRI only provide vague spikes or dips in activity in response to these same conditions. Additionally, EEG may be employed to track mental processing in the absence of physical response. This is because certain ERP components can be traced according to purely cognitive or subconscious processing (Sinha, 2009). Likewise, as further evidence in this paper will demonstrate, some ERP components possess a significant degree of test-retest reliability. These components are also known to be altered in some clinical populations. Thus, EEG can be

used to track signalling and processing over time. This makes it ideal for long-term studies, sleep studies, and prognostic analysis.

Applications of EEG

Currently, EEG is chiefly employed clinically as a pivotal tool for tracking seizures and other seizure-like conditions (Bressler, 2002). Unique waveforms recorded using EEG are commonly used to differentiate between various forms of epilepsy, deep-brain hypo/hyperkinesia, migraines, and certain types of encephalopathy (Sinha, 2009). EEG is often employed in the diagnosis of countless other neurological and behavioral disorders including autism, hemorrhages, Alzheimer's, and ADHD (Gauthier, 2006; Sinha, 2009; Ristner, 2009)

As discussed prior, EEG can also be employed to study the progression of many diseases. Because EEG accurately tracks regional activity, it is commonly used to observe the rate of degeneration in various forms of dementia. For example, some vital benchmarks in the progress of Alzheimer's disease can be predicted by the loss of alpha and beta wave activity recorded in EEG studies (Gauthier, 2006). Creutzfeldt-Jakob disease (CJD), a fast acting form of prion caused spongiform encephalopathy, has also been prognocized by EEG. Essentially manifesting as a fast-acting vacuolization similar to the effects seen in Alzheimer's, CJD thus shows similar rapid changes in certain waveform expressions (Creutzfeldt-Jakob Disease Fact Sheet, 2003). Recent work by Westhall has also demonstrated EEG's ability to record the changes in neural in comatose patients recently revived from cardiac arrest. By observing EEG burst suppression in resuscitated patients, doctors can make accurate assessments regarding the patient's recovery (Westhall, 2017).

EEG is also commonly used in a number of other clinical applications beyond standard diagnostic procedures. Anesthesiologists occasionally use continuous EEG studies to measure the effects of anesthesia on surgical patients or to determine the necessary ongoing dosage for patients in medically induced comas (Jackson, 2014). Furthermore, EEG has been used to trace cortical perfusions in instances of hemorrhages or stenosis corrections (Gauthier, 2006). Localized memory assessments such as the Wada Test likewise employ EEG studies to help localize specific signal clusters (Jackson, 2014).

Beyond medical implementation, electroencephalograms have served as important procedures in various forms of research. Their numerous aforementioned advantages in imaging have made EEG's a staple in the fields of cognitive neuroscience, economics, psychology, linguistics, and neuroanatomy (Britton, 2016). Over the last three decades EEG has been used to study a wide array of neuroscientific mechanisms including but not limited to: personality, social interaction, decision making, language processing and production, attention, social defects, human-computer interface interaction, and coordination (Swartz, 1998). Recent advancements in EEG hardware has allowed a new commercial market for business and technology focused human subject studies. Companies such as NeuroSky have begun to develop wireless EEG headset to aid research in the burgeoning new field of neuromarketing. These lightweight portable devices help many organizations track the mental patterns that dictate reactions and decisions dealing with a wide array of products ranging from tangible goods to music.

Mechanism of EEG

Electroencephalograms are recorded using special hardware which links the brain's changing voltage to a recording software. The traditional setup consists of a skull-cap containing

electrodes which are then positioned over key regions of a subject's scalp as specified by the 10-20 System (Figure 1). These electrodes are then wired to a differential amplifier which enhances the voltage between a given electrode and a reference electrode, helping to filter regional signals from other erroneous electrical noise in the environment. These are measured according to the pushing and pulling of electrons in the metal electrodes as a result of their interaction with the electromotive forces produced during the volume conduction of various ions in the brain. These differences are then plotted over time, resulting in a standard EEG reading.

It should be noted that these electrodes are only able to measure larger instances of summed activity, as the voltage of a single neuron is far too minuscule to register on a standard EEG. Instead, EEG relies on the simultaneous activity of thousands of spatially symmetric neurons with similar orientations. Thus, it is widely believed that the majority of the recorded voltages arise from cortical pyramidal cells as they tend to form symmetric networks and fire in synchronous bursts (Jackson, 2014). The activity of deeper brain regions is thought to be either lost due to decay as the signal reaches the scalp or masked by electrical patterns in the cerebral cortex.

Event-Related Potentials

Neuroscientists who use EEG to study the brain chiefly rely on a specific type of brain response known as an event-related potential (ERP). An event-related potential is defined as a time dependent signal elicited in the brain in response to a specific cognitive, visual, auditory, or motor stimuli (Sinha, 2009). The ERP is typically understood to represent the direct relationship between the environment and changes that result from the brain's constant interpretation of that environment. These changes in voltage arise from the activation of postsynaptic terminals in

specific cortical regions. When a set of congruently aligned pyramidal neurons are activated simultaneously in reaction to a stimuli, a regional shift in voltage is elicited which, depending on the specific nature of the stimulus, will appear as a spike, dip, or wave oscillation in the recorded EEG (Ristner, 2009).

Event-related potentials were first identified by Hallowell and Pauline Davis. They would later go on to record these early signal changes on conscious humans in their 1939 study. The first purely cognitive ERP component was identified decades later by Walter Grey. His identification of what called the contingent negative variation (CNV) kindled a new age of ERP focused EEG research in neuroscience. Since then at least eleven different ERP components have been identified by researchers, each of which exemplify a unique stimulus-response correlate of neural activity.

Most neuropsychologists categorize the different ERP components based on two key parameters. The first, known as “exogenous” ERP components, arise and peak in the first 100 milliseconds following the introduction of a stimulus. These early components are elicited by immediate sensory stimuli such as auditory or visual cues and are thus dependent on the physical intensity and frequency of those exogenous stimuli. The second category, known as “endogenous” ERP components, tend to appear later in a given EEG recording. Endogenous ERP components thus reflect critical cognitive processing and generally focus on “conscious” mechanisms (Sinha, 2009). ERP components are likewise classified by their continuity throughout a given EEG.

Due to the fact that brain activity from all areas of the cerebrum constantly permeate the human cortex, specific ERPs and their components must be derived mathematically from a series of EEG recordings. After conducting several consistent trials, an experimenter may average their

recordings together to mitigate the other ongoing brain processes. ERPs are typically derived from multiple (20+) segments of EEG recordings. Each of these EEG recordings are time-locked to an evoked stimulus. Since the residual brain activity is considered to be random with respect to the time-locked event, the so-called “noise” in a given recording will be diminished by the averaging process. Because the neural activity is presumed to remain constant over repeated presentations of the stimulus, the resulting “signal” is therefore presumed to survive the averaging process. Thus, the mean calculated from these recordings is a distinct record of brain activity with an improved signal-to-noise ratio.

Use of ERP in Medicine and Research

It has been well-documented that ERP can be used as an effective focus for EEG studies in both clinical setting and neuroscientific research. Over the last few decades, changes in ERPs have been linked with a variety of neurodegenerative disease, injuries, and other neurological conditions. For example, Boutros et al. (1995), demonstrated how patients suffering from Alzheimer’s exhibited consistent dips in amplitude in the P50, N100, P200, and P300 ERP components. Other studies have also shown certain ERP components can be used to diagnose other dementing diseases such as Parkinson’s and Creutzfeld-Jakob Disease (*Creutzfeld-Jakob Disease Fact Sheet*, 2003). Auditory related ERP components (such as P300) have also been shown to change as the result of various diseases including epilepsy, multiple sclerosis, and certain forms of TBI. It should be noted, however, that while ERPs have been shown to be sensitive to disorders in a variety of clinical contexts, the ability of ERP measures to discriminate between clinical disorders is largely unknown.

An attractive feature of ERPs over other neurometrics is that they are thought to be a direct reflection of cognitive functions of the brain. Duncan et al. (2003) demonstrated a correlation between closed head injuries, impaired information processing, and specific deficits in visual and auditory tasks. These deficits were measured by comparing the reduced N100, N200, P200, and P300 ERP components in patients suffering from TBI against the ERP responses in healthy control participants. D'Arcy and Marchand (2003) likewise found that ERP components could effectively assess language paucity following strokes. Their neurophysiological data suggests that N400, an ERP component related to semantic processing, was highly impaired in individuals with clear language deficits following a left hemisphere stroke.

Another component, the P300 has proven to be a particularly robust indicator of higher level processing, making it a crucial component of study in various cognitive experiments. One problem with the use of the P300 as a diagnostic indicator, however, is that it has been shown to be sensitive to the presence of a wide variety of clinical populations but it's diagnostic specificity is far from clear.

Brief Neurometric Battery

Further applications of ERP measures in biomedical and research settings have been recently enhanced through the development of a novel brief neurometric battery (BNB) by Kieffaber et al (2016). This procedure was used to derive five different traceable oscillatory measures and eight distinct ERPs in a brief recording period. The BNB includes (1) a standard or deviant (frequency or ISI) tone, (2) a compound visual stimulus set and (3) an auditory paired-click stimulus. The BNB thus provides neurometric profiles which illustrate the combined

changes in multiple ERPs which, according to Kieffaber et al (2016), are sensitive to age-related changes in brain function even in the absence of clinically significant changes in global cognitive functioning as measured by the Montreal Cognitive Assessment (MoCA). Because the BNB is able to characterize responses from both healthy and impaired brains across multiple ERPs it is hugely beneficial to physiopsychological research as it allows for a broader incorporation of ERP data in a short amount of time. Already, the BNB has been utilized in studies focusing on the ERP changes that result from aging (Kieffaber et al. 2017), Alzheimer's disease (Cunningham et al., 2015), and autism spectrum disorders (Gayle et al., 2016).

Reliability in the ERP Components of the BNB

Despite decades of research using ERPs to make inferences about cognitive functions of the brain and, more recently, as diagnostic indicators of clinical disability, little is known about the psychometric properties of these measures. Understanding the psychometric properties like validity and reliability are important because they dictate the utility of the ERP components in a clinical setting. The validity of an ERP refers to the extent to which there is agreement about the cognitive process it measures. Although it may be some time before consensus is reached on this issue, the primary aim of the present research was to determine the reliability of ERP components measured by the BNB. The focus of this research was on the test-retest reliability of seven ERP components in order to determine which measures can be considered stable measures of cognitive deficits.. The components measured included the P300, P50, freqMMN, Direction MMN, Duration MMN, ERN, and C1.

The first, known as P300 or simply P3, is a waveform which appears in EEG measures during executive functions such as decision making. The P300 typically appears as a brief

positive voltage surge which appears most clearly in electrodes around the parietal lobe. It is a preferential measure of categorization and higher mental function as it appears consistently in response to specific executive paradigms and is not altered by the physical attributes of the stimulus.

The second ERP component, P50, correlates to the neural activity resulting from an auditory stimulus, usually a click. P50 is typically used in EEG studies to measure a subject's ability to sort out redundant sensory stimuli. Several researchers have noted that P50's suppression can serve as neurophysiological marker of certain disorders including schizophrenia and dementia (Todd, 2008).

Visual mismatch negativity (vMMN) is a special case of the standard mismatch negativity ERP in which the brain responds to an outlying visual stimulus that breaks an established pattern in a series of visual stimuli. Mismatch negativities are frequently studied by neuroscientists because of their ubiquitous occurrence regardless of a subject's attentiveness. The vMMN therefore occurs when a single stimulus varies in size, color, pattern, orientation, or duration. We primarily focused on vMMN's dealing with changes in direction of movement (Direction MMN) and the duration of a visual stimulus (Duration MMN).

Two other mismatch negativity ERP components were implemented in the BNB as well. The inter-stimulus interval MMN (MMN_{ISI} or MMN_{GAP}) measures the attenuation of auditory MMN responses between extended time intervals, particularly in instances of Alzheimer's and chronic alcoholism (Graves, 2015). Of these interval based MMNs we primarily focused on the frequency MMN (freqMMN), which arises in response to the altered frequency of a presented auditory stimulus. Deficits in the freqMMN have likewise been linked to the pathology of schizophrenia, narcolepsy, and developmental dysphasia (Todd, 2008).

The C1 ERP is a component that arises during visual processing in the striate cortex of the human brain. The C1 is elicited at the onset of any given visual stimulus, but its polarity is dependent on the location of the given stimulus, thus making C1 an important marker of visual field processing. C1 is not affected by changes in a subject's attention, thus making it more robust than its similar counterpart P1.

The error related negativity (ERN or Ne) is a time-locked ERP component which is elicited following an observed error in a procedure. Characterized by an acute negative voltage surge in the frontal lobe, the ERN usually arises simultaneously with an incorrect motor or choice response. Like some of the previously discussed ERP components, the ERN is experimentally useful because it can be seen regardless of a subject's attentiveness. Noticeable differences in the intensity of the ERN have been observed in subjects suffering from depression, alcoholism, and other forms of addiction.

Method

To determine the viability of the BNB's test-retest reliability, two trials were performed on subjects. The second trial was administered after an interval of 7 ± 1 days. The resulting ERPs were recorded in both sessions and then analyzed to assess their consistency. Intraclass correlation (ICC), a referential statistic used to determine relatedness within a group, was used to determine the test-retest reliability of the seven ERP components.

Participants

Our study utilized twenty human subjects recruited from a pool of students at The College of William and Mary. The participant pool consisted of 9 female and 11 male subjects

between the ages of 18 and 22 (Avg Age= 19, SD= 1.44). All subjects had normal or corrected to normal vision and hearing. No subjects possessed any known substantial pre-existing neurological disorders that would have negatively impacted the outcomes of the BNB recordings. All subjects consented to their participation in the study through written compliance prior to the experimental trials.

Experimental Design

At the experiment's onset, a resting EEG was recorded for all participants for a total of 2 minutes. The first minute was recorded with the subject's eyes open while the second was recorded with the subject's eyes closed. Once these standard recordings were collected the Brief Neurometric Battery trials began. The BNB, which is comprised of several audio-visual response tasks, was systematically presented to each subject through a program designed in MATLAB (Mathworks Inc., USA).

For auditory stimuli, subjects were given binaural pneumatic headphones through which a train of standard tones were presented. Each train of tones were presented every 2600ms at 80 dB and 500 Hz for a duration of 100 ms with a 5ms rise and fall. The various ERP components elicited specifically by auditory stimuli were collected through recordings of a subject's response to changes in the standard auditory trains. The frequency Mismatch Negativity (freqMMN) was elicited through the introduction of a deviant tone (1000 Hz) which was used in place of the standard tone in 15% of trials. Another MMN, the duration MMN, was likewise elicited in 15% of trials by introducing the standard tone after an altered inter-stimulus interval (ISI) of 1300 ms rather than the standard 2600 ms. A paired-click paradigm was then used to invoke the P50 ERP. This stimulus consisted of two 1 ms square-wave tones separated by 250 ms amidst the standard

135 standard auditory trials. This allowed for the isolation of P50, as the paired-click paradigm was presented within the interval of two standard tone trains.

To measure visually elicited ERPs, participants were shown a screen with a white background and a fixation cross situated in the screen's center. Paired shapes (circle, square, triangle, and diamond) were shown on either side of the fixation cross. Subjects were then tasked with responding according to the shape pairing with the left and right control buttons according to a set of randomly generated instructions. Half of the participants were tasked with specifically responding to one shape, while the other half were tasked with responding to another shape. The specific keys assigned to each target were randomized for every participant. Target stimuli were shown on either side of the central fixation cross. These stimuli were randomly flashed on each side with equal probability, forcing the subjects to lateral shift their attention in accordance with the target stimulus's location. Distractors (one of the four shapes depending on the randomized instructions) were also occasionally shown on either side of the central cross. The P300 component was measured by setting the relative frequencies of the target (P300a) and the distractors (P300b) to 85% and 15% respectively. The C1 wave was isolated by simultaneously showing a rectangular sine grating at the bottom or top of the screen. This grating had an equal chance of appearing on either upper or lower half. Once it appeared it would then appear to move either to the left or the right. The procedure was programmed such that one randomly selected direction would appear in 87% of trials while the opposite direction only appeared in 13% of trials. These directionally dependent stimuli helped isolate the direction MMN.

An outline of these aforementioned tasks can be seen in Figure 2. All visual stimuli were presented for a duration of 250 ms as well as variable onset elicited after a standard tone in the 100-950 ms interval. The subject's responses to the randomly assigned shape pairing tasks were

then coded and measured to isolate the ERN component. Both auditory and visual stimuli were conferred over a 2600 ms interval without overlap. These trials were repeated 400 times in a single session.

Procedure

Upon their arrival to the laboratory, all subjects filled out a standardized demographic questionnaire, as well as hearing and vision tests to assess their baseline perception. This included the Sensory Perception Quotient (SPQ), though it was not included in our final analysis. Once the initial assessment was completed, subjects were then fitted with an EEG skullcap and tasked with completing the BNB on a desktop computer in an electronically shielded recording booth. Subjects were allowed a brief break between trials. The total session time for each participant was approximately 30 minutes.

EEG Reporting

A DBPA-1 Sensorium bio-amplifier was used to gather EEG data in all trials. The EEG continuously collected data at 2000 samples per second. Participants were placed in an electronically shield booth and were equipped with a fabric skullcap fitted with 28 Ag-AgCl sintered electrodes. The reference electrode was positioned on the tip of the subject's nose and the ground electrode was placed in the center of the subject's forehead. Electrodes were placed above, below, and on the lateral canthi of the subject's eyes in order to measure both vertical and horizontal eye movements. The impedance of the electrodes was adjusted to 20 k Ω .

EEG Data Analysis

The data was compiled and analyzed using EEGLab and R. Quality of data was managed using laboratory standards. A spherical spline was used to interpolate noisy channels. Other aberrant readings, such as those generated by eye movement, were identified and removed using independent component analysis. Data was further streamlined through the creation of stimulus-locked epochs ranging from -200 to 1000 ms around a given stimulus. For P50 components, baseline corrections were applied across a 100 ms pre-stimulus interval and trials that included recordings beyond $\pm 50 \mu\text{V}$ were excluded. A IIR Butter A filter of 10-50 Hz was applied when studying the P50 components, while a filter of 20 Hz was applied to the epoched data for the other ERP components. For these latter trials, voltages in excess of $\pm 100 \mu\text{V}$ were excluded and baseline corrections were made with a 200 ms pre-stimulus interval. Difference waveforms were calculated for each ERP component. Our mean amplitude measurements were derived from the grand average difference waveforms and topographies.

Auditory ERP difference waves for the P300 and MMN components were calculated by subtracting a subject's responses to standard stimuli from their response to altered stimuli. Frequency and ISI MMNs were gathered from the Fz electrode at 100-150 ms and 150-250 ms intervals. The amplitude difference across S1 and S2 at Fz from 50-80 ms after the stimulus was used to calculate the P50 suppression.

The mean amplitudes of the visual MMN were recorded from 150-250 ms after the stimulus onset at the Oz electrode. Mean amplitudes for the P300a component were recorded from 250-350 ms at the Cz electrode. Mean amplitude measurements for the P300b component were recorded from 350-900 ms at the Pz electrode. When determining the value of the C1 component, recordings from stimuli presented at the top of the screen were subtracted from recordings of stimuli presented at the bottom of the screen. These mean amplitudes were then

taken with a latency interval of 50-100 ms at the Cz electrode. A latency range of -20-150 ms at the Fz site was used to measure the ERN component.

Trials which measured vMMN and C1 purposefully excluded the P300a and P300b targets due to the later components relative rarity. Those trials that contained vMMN deviants likewise excluded the P300a, P300b, and C1 measures. These measures were taken to ensure that certain unwanted stimuli probability interactions did not take place.

Results

In order to determine the consistency of the ERP components across the various sessions for each subject an intraclass correlation coefficient (ICC) was computed for each of the ERP components. The results of these tests are shown in the corresponding figures (3 and 4). The ICC for P300 was at 0.37 with a 95% confidence interval from -0.56 to 0.75, $F(19,20)= 1.6, p>.05$). ERN analysis revealed that the component did not show significant reliability across trials. ERN's ICC was -0.62 with a 95% confidence interval from -3.03 to 0.35, $F(19,20)= 0.62, p>.05$). Direction MMN was analyzed and was found to not show significant reliability across trials. The ICC of direction MMN was -0.48 with a 95% confidence interval from -2.67 to 0.41, $F(19,20)= 0.68, p>.05$). Lastly, the data for C1 was plotted and analyzed, likewise demonstrating no test-retest reliability. The C1 ICC was -0.026 with a 95% confidence interval from -1.55 to 0.59, $F(19,20)= 0.97, p>.05$).

Analysis was then performed on the auditory ERP components. P50 analysis failed to demonstrate reliability across both trials. The P50 ICC was 0.0184 with a 95% confidence interval from -1.44 to 0.61, $F(19,20)= 1.02, p>.05$). Analysis of the frequency MMN revealed a high degree of reliability between the two sets of measures. The freqMMN ICC was 0.54 with a

95% confidence interval from -0.14 to 0.82, $F(19,20)= 2.2, p<.05$). The duration MMN was analyzed and was also found to lack test-retest reliability across trials. The duration MMN had an ICC of 0.42 with a 95% confidence interval from -0.44 to 0.77, $F(19,20)= 1.7, p>.05$).

Discussion

The results suggest that the majority of the ERP components measured using the BNB did not possess a great deal of test-retest reliability. With the exception of the frequency MMN, the remaining readings for each ERP component in the 20 participants were too erratic to be considered statistically consistent. While this seemingly mars further implementation of ERP in diagnostic or prognostic settings, further analysis of the test-retest reliability of these measures will hopefully prove more apt once certain confounding experimental factors are eliminated. As many previous papers have found ERP components to be viable neurophysiological markers of certain illnesses and injuries, our findings do not necessarily detract from the validity of their continued use. However, until we can fully account for the inconsistent measures received during our recordings, these ERP applications should continue to use conventional, one-at-a-time, recording procedures rather than nested procedures like the BNB.

freqMMN

It has been well established that changes in the frequency of an auditory tone can be adequately distinguished throughout a given population of participants without hearing impairment. Naatanen (1992) has shown that a familiar train of tones is retained within an individual's short-term memory, allowing for the discernment of deviant tones. This is an important factor in human perception, language recognition, and auditory attention. Having

found that freqMMN measures are robust across trials, we now know that freqMMN can be an effective prognostic tool for an extended period of time. This has successfully built upon earlier single-study trial analysis for MMN components (Bishop and Hardiman, 2010). As changes in freqMMN may arise from physical impairments to auditory processing, it is thus sensible to assume that patients suffering from disorders which affect auditory perception can be accurately identified with the BNB. Previous studies have linked deficits in freqMMN to a variety of disorders, including but not limited to schizophrenia, developmental dysphasia, and other similar illnesses (Todd, 2008).

Limitations

As the data analysis has demonstrated, the other six ERP components studied in this experiment did not return statistically reliable results across both trials. While this would initially indicate these components' incompatibility in multi-trial EEG assessments, we must consider the limitations and shortcomings of our own experimental procedure. First, much of the extraneous background could be nullified and clarity improved if our data included a larger pool of participants and trials. More subjects would have allowed for a more concrete normalization of the average recordings for each ERP component. If this procedure could be repeated again with twice as many subjects, results would likely indicate a higher degree of reliability for each component. Likewise, more recordings and trials during each session would have expanded the data pool enough to help mitigate the effects of other outlying recordings. Higher rates of sample collection, a greater number of repeated tasks for each ERP component, and an extended session time would have provided recordings far more characteristic of the neural activity resulting from each stimuli. Recordings were gathered from single electrode measures, which is the most

common method of recording in cognitive neuroscience research. There is data to suggest that aggregate measures may prove to be more reliable (Escera, 2000). However, a new battery could combine all these measures in one sitting. That being said, an aggregate measuring system may make it difficult to compare results with other papers. Likewise, if we were to repeat our trials but measure each ERP individually, reliability may increase. Including so many component tests in one experiment might affect each ERP's individual data. Additional sessions following the two held in this experiment would also provide a better understanding of the lasting reliability of these recordings. Including an extra third or fourth session would not only provide more data but would also help extend our understanding of that data's internal consistency over a longer period of time.

Future Directions

As always, this study leads to many new avenues whose further investigation would surely yield additional information and operative applications. Although our study relied solely on subjects without known neurological conditions, as well as normal or corrected hearing/vision, further tests using the BNB can be performed to assess its clinical viability. Once the test-retest reliability of these ERP components have been verified, they may be utilized in clinical trials with actual patients to assess their efficacy in a medical setting. Likewise, extending this study to patients of varying ages would likewise prove useful. Future studies should also consider additional neurophysiological measures, including multi-scale entropy, coherence, and event-related spectral perturbation (ERSP). These measures, along with others, will provide a more complete neuropsychological profile of patients, allowing for more accurate evaluations of a patient's physical and mental health.

Figures

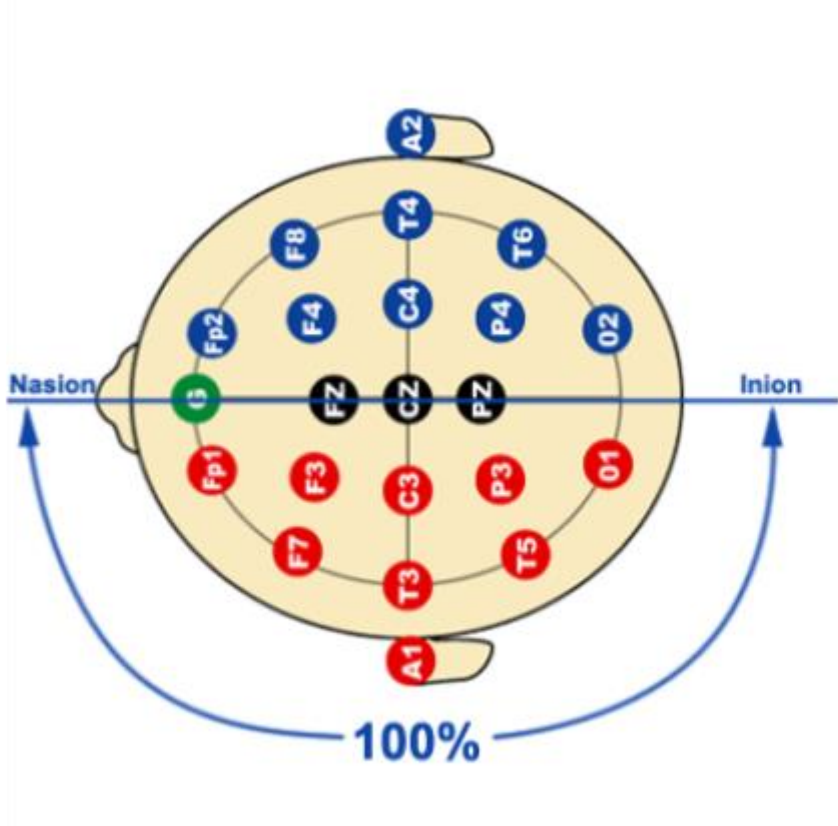

Figure 1. The 10-20 System of Scalp Electrode Arrangement

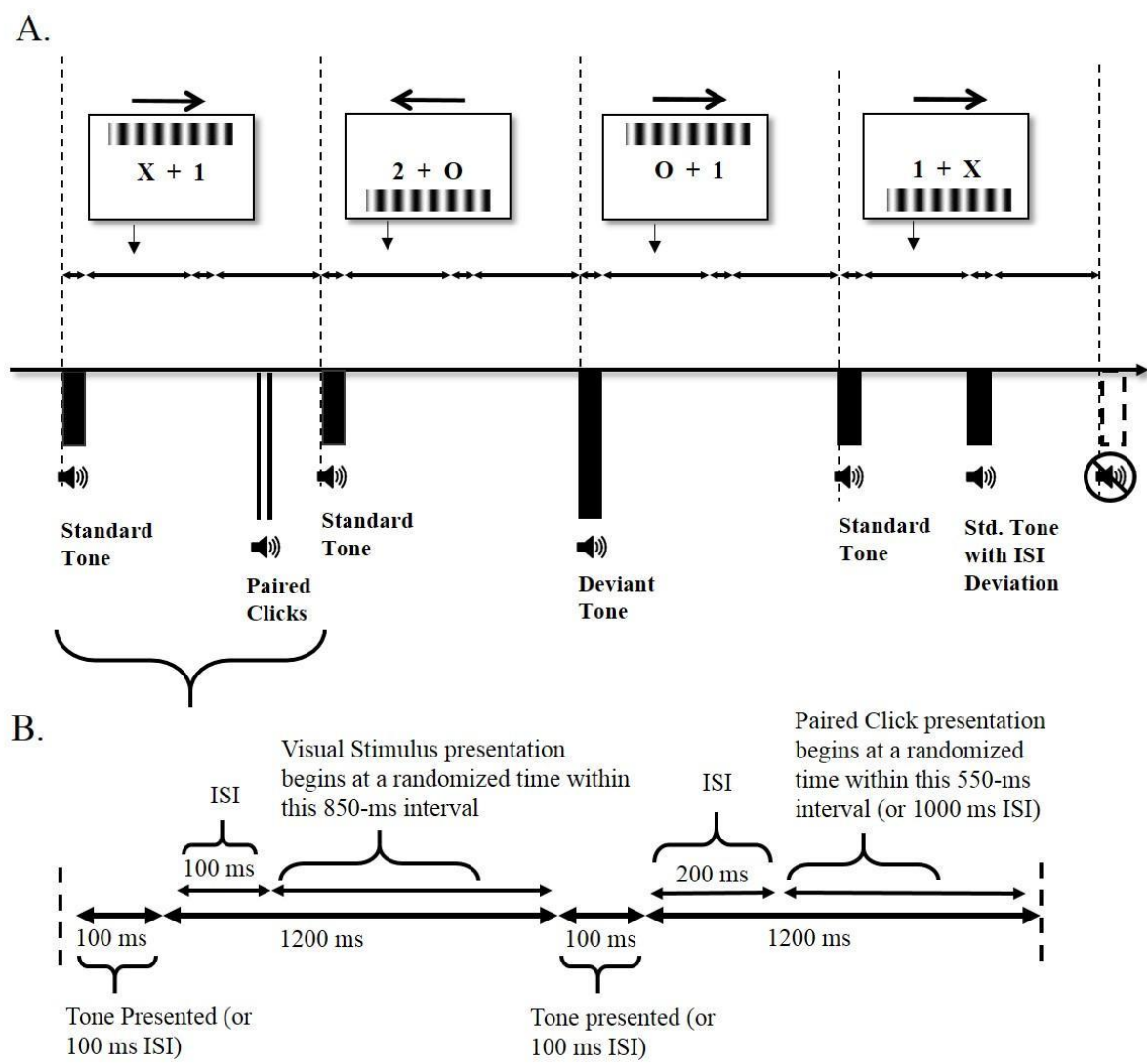

Figure 2. The Brief Neurometric Battery Task Schematic

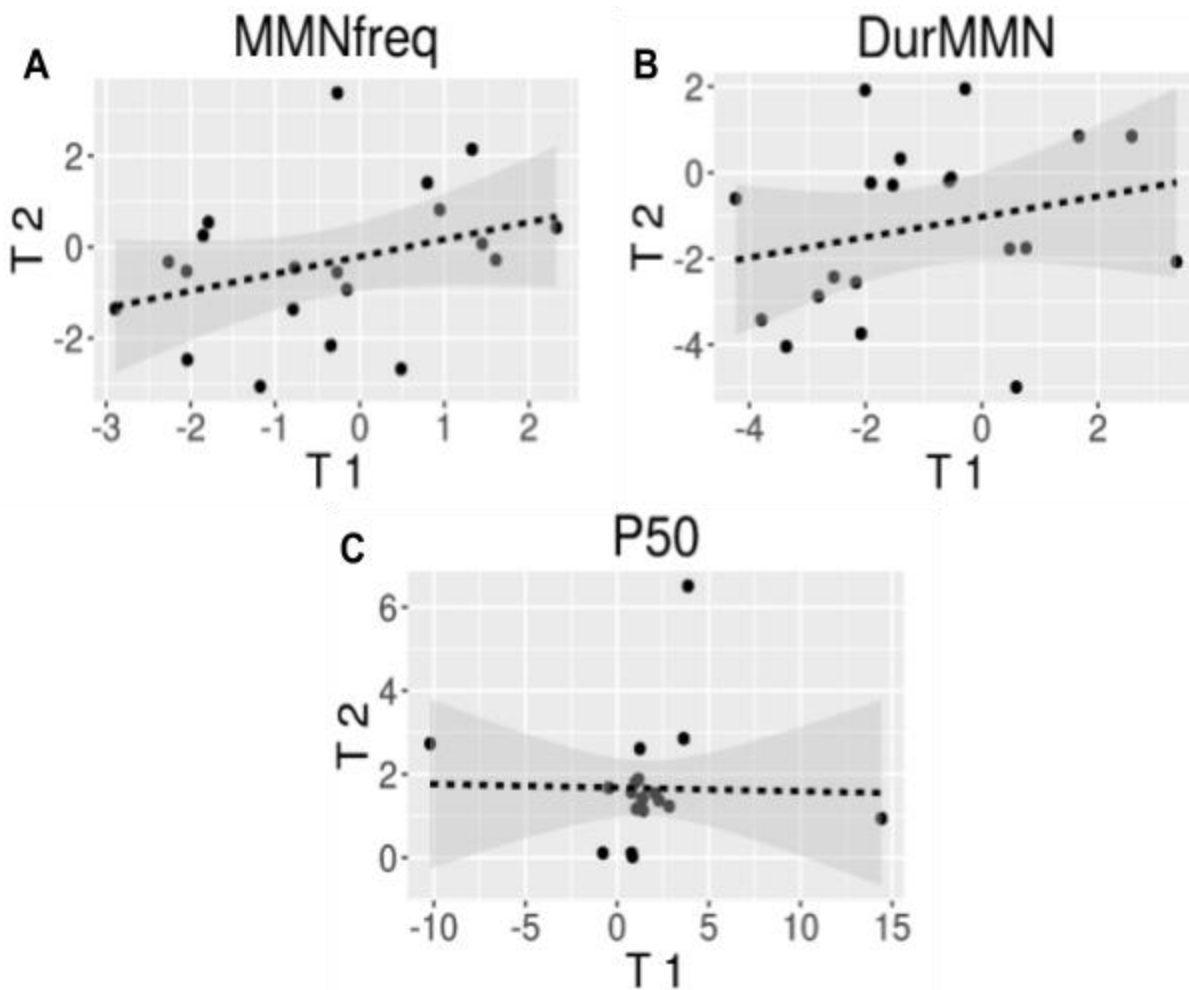

Figure 3. Scatter Plots for auditory ERP components. T 1/2 = "Trial" "1"/"2". Shaded region reflects 95% confidence interval. Dotted line reflects least squares best fit.

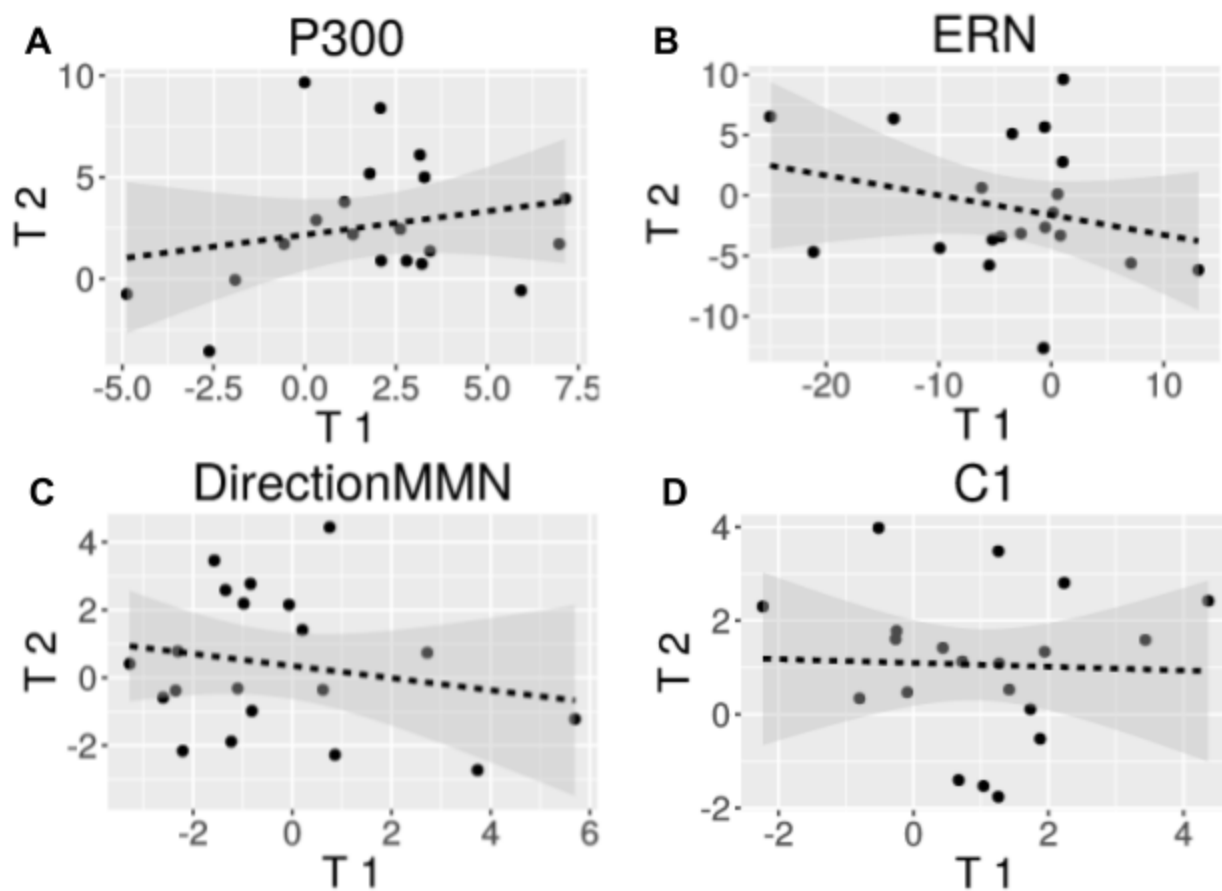

Figure 4. Scatter Plots for visual ERP components. T 1/2 = "Trial" "1"/"2". Shaded region reflects 95% confidence interval. Dotted line reflects least squares best fit.

References

- Beres, A. (2017). Time is of the Essence: A Review of Electroencephalography (EEG) and Event-Related Brain Potentials (ERPs) in Language Research. *Applied Psychophysiology Biofeedback*, 247-255.
- Boutros. (1995). Evoked potentials in subjects at risk for Alzheimer's disease. *Psychiatry Research*, 57-63.
- Bressler, S. (2002). Event-Related Potentials. In S. Bressler, *The Handbook of Brain Theory and Neural* (pp. 412-415). Cambridge, MA: MIT Press.
- Britton, J. (2016). *Time is of the Essence: A Review of Electroencephalography (EEG) and Event-Related Brain Potentials (ERPs) in Language Research*. Chicago: American Epilepsy Society.
- Creutzfeld-Jakob Disease Fact Sheet*. (2003, March). Retrieved from National Institute of Neurological Disorders and Stroke:
<https://www.ninds.nih.gov/Disorders/Patient-Caregiver-Education/Fact-Sheets/Creutzfeldt-Jakob-Duncan-Disease-Fact-Sheet>
- D'Arcy and Manchard. (2003). Electrophysiological assessment of language function following stroke. *Clinical Neurophysiology*, 662-672.
- Duncan. (2003). Event-related potential assessment of information processing after closed head injury. *Psychophysiology*, 45-59.
- Escera. (2000). The individual replicability of mismatch negativity at short and long inter-stimulus intervals. *Clinical Neurophysiology*, 546-551.
- Gauthier, S. (2006). *Clinical Diagnosis and Management of Alzheimer's Disease, Third Edition*. CRC Press.

- Gayle, L. (2016). Neurometric Profiling Of Autism Spectrum. *Psychology Commons*, 7-59.
- Graves, K. (2015). Development of an eeg-based neurometric battery for the assessment of cognitive decline in patients at risk for Alzheimer's disease. *Alzheimer's & Dementia*, 54.
- Hardiman, D. B. (2010). Measurement of mismatch negativity in individuals: A study using single-trial analysis. *Psychophysiology*, 697-705.
- Jackson, D. B. (2014). The neurophysiological bases of EEG and EEG measurement: a review for the rest of us. *Psychophysiology*, 1061-1071.
- Kieffaber and Dybel, L. (2017). *The Neurometric Correlates of Trauma Using the Brief Neurometric Battery (BNB)*. Williamsburg, VA: W&M Publish.
- Kieffaber, P. D., Okhravi, H. R., Hershaw, J. N., & Cunningham, E. C. (2016). Evaluation of a Clinically Practical, ERP-Based Neurometric Battery: Application to Age-Related Changes in Brain Function. *Clinical Neurophysiology*.
<http://doi.org/10.1016/j.clinph.2016.01.023>
- Näätänen R. Attention and brain function. Hillsdale, NJ: Lawrence Erlbaum; 1992
- Ristner, M. (2009). *The Handbook of Neuropsychiatric Biomarkers, Endophenotypes and Genes*. Springer Science and Business Media.
- Sinha, S. S. (2009). Event-related potential: An overview. *Industrial Psychiatry Journal*, 70-73.
- Swartz, B. (1998). *Electroencephalography in Clinical Neurophysiology*. West Los Angeles: Elsevier.
- Todd, J. (2008). Deviant Matters: Duration, Frequency, and Intensity Deviants Reveal Different Patterns of Mismatch Negativity Reduction in Early and Late Schizophrenia. *Biological Psychiatry*, 58-64.

Westhall, E. (2017). Electroencephalography as a Prognostic Tool after Cardiac Arrest. *Seminars in Neurology*, 48-59.