

5-2015

Studies of Polarized Helium-3 Cell Lifetimes

Andrew N. Smith

Follow this and additional works at: <https://scholarworks.wm.edu/honorsthesis>



Part of the [Nuclear Commons](#)

Recommended Citation

Smith, Andrew N., "Studies of Polarized Helium-3 Cell Lifetimes" (2015). *Undergraduate Honors Theses*. Paper 203.

<https://scholarworks.wm.edu/honorsthesis/203>

This Honors Thesis is brought to you for free and open access by the Theses, Dissertations, & Master Projects at W&M ScholarWorks. It has been accepted for inclusion in Undergraduate Honors Theses by an authorized administrator of W&M ScholarWorks. For more information, please contact scholarworks@wm.edu.

Studies of Polarized ^3He Cell Lifetimes

A thesis submitted in partial fulfillment of the requirement
for the degree of Bachelor of Arts / Science in Department from
The College of William and Mary

by

Andrew Smith

Accepted for HONORS

(Honors or no-Honors)

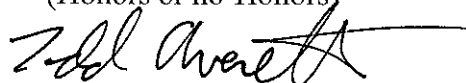

Dr. Todd Averett, Director

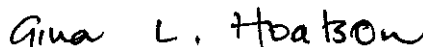

Dr. Gina Hoatson, Physics



Dr. Cary Ross Humber, Mathematics

Williamsburg, VA

May 5, 2015

Studies of Polarized ^3He Cell Lifetimes

Andrew Smith, Professor Todd Averett

May 11, 2015

1 Abstract

This year I worked with Professor Averett to fill and analyze several ^3He target cells. Many of these cells are taken from our lab to eventually be used as targets at Jefferson Lab for nuclear physics experiments. Our ultimate goal was to test a number of different variables in an attempt to improve the lifetimes of future targets. Over the course of this year we tested several different cells and eventually got some improvements in our cell lifetimes due to a couple factors, including a new tubing getter and larger cell size. We have not quite identified exactly what was causing the previous targets to have poor lifetimes, but we have developed a method that seemed to produce cells with longer lifetimes. The testing of these processes is not complete, but getting a couple of improved cells is very promising.

2 Introduction

2.1 Polarization

The goal of the polarized ^3He lab is to create target cells filled with highly polarized helium-3 gas. These targets are then used at Jefferson Lab, because polarized ^3He reasonably approximates a polarized neutron target. ^3He has two protons and one neutron, and the proton spins effectively cancel each other, allowing us to represent the ^3He atom as a neutron in collisions. An example diagram of a cell is shown in Figure 1.

Each cell is filled with nitrogen gas, ^3He gas, and rubidium. Hybrid cells are also filled with potassium. Once the cell is filled and heated, a magnetic field and lasers are applied to the cell in

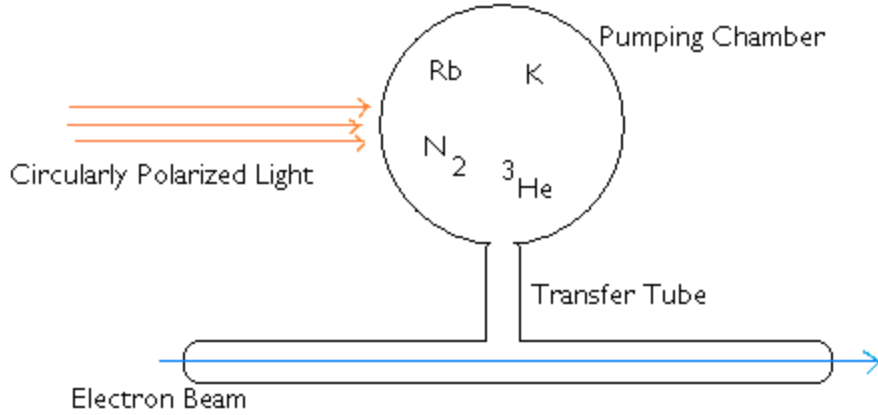

Figure 1: Example of a cell [4]

order to polarize the ^3He nuclei. The magnetic field creates a Zeeman shift in the electron energy levels of the alkali metals which splits degenerate energy levels into two close levels, one for $+1/2$ spin and the other for $-1/2$ spin. The presence of the magnetic field causes the atoms with $+1/2$ spin to have a slightly higher energy than those with $-1/2$ spin (see Figure 2). Where before each (L, m) state had equal energy spacing between levels, now they are slightly different, allowing us to use this to our advantage to trap the rubidium atoms in the spin up state. We shine a right circularly polarized laser at the rubidium. Rubidium and potassium are alkali metals, and therefore behave similar to the hydrogen atom. At the right wavelength, the photons will be absorbed by the rubidium in the $S_{1/2}$ ($L=0, m=-1/2$) state, and they will transition to the $P_{1/2}$ ($L=1, m=1/2$) state. From there, the rubidium can decay back to the $L=0, m=-1/2$ state or the $L=0, m=+1/2$ state. The rubidium in the latter state are effectively stuck; the incoming photons are not tuned to their transition energy or polarization, and so they stay in the spin up state, which is exactly what we want. The rubidium then collides with the potassium, transferring its spin in the process. The potassium then has the correct spin and the rubidium is depolarized, but quickly regains it due to the laser. This process takes only milliseconds to polarize the rubidium and potassium to at least 90% [1]. This process, known as optical pumping, is shown in Figure 2.

The potassium and rubidium atoms continuously collide with the ^3He atoms, transferring their angular momentum to the nuclei. This occurs less frequently as the interaction cross section is quite small. Meanwhile, the cell is also continuously depolarizing or relaxing due to interactions

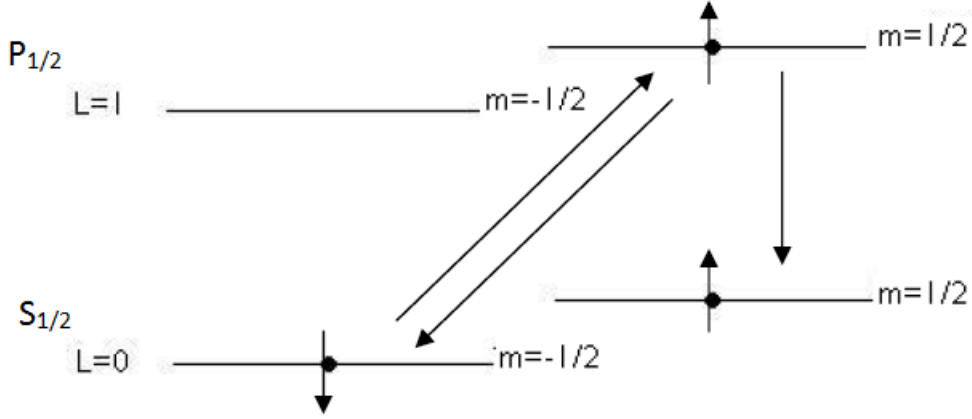

Figure 2: Illustration of the Zeeman shift and optical pumping[4]

with the glass walls as well as interactions with other atoms that do not preserve the polarization. When an atom collides with the glass it often relaxes, losing its spin. Ultimately a good cell will have a polarization of about 50-60%. The definition of the polarization is given by equation 1, where N^\uparrow is the number of parallel spins, and N^\downarrow the number of antiparallel spins. The main goal is to simultaneously increase the polarization while decreasing the relaxation rate.

$$\text{Polarization} = \frac{N^\uparrow - N^\downarrow}{N^\uparrow + N^\downarrow} \quad (1)$$

The rate of polarization follows equation 2, where Γ_r is the relaxation rate and γ_{SE} is the polarization rate due to spin exchange.

$$\frac{dP}{dt} = -P(\Gamma_r + \gamma_{SE}) + \gamma_{SE} \quad (2)$$

Solving for the polarization yields the following solution, where P_0 is the initial polarization [3].

$$P(t) = P_0 e^{-(\Gamma_r + \gamma_{SE})t} + \frac{\gamma_{SE}}{\Gamma_r + \gamma_{SE}} \quad (3)$$

2.2 Experimental Setup

An unpolarized cell is placed in the oven of the apparatus shown in Figure 3. It is heated to around 180°C (230°C for hybrid cells). As soon as it reaches this temperature, lasers are turned on

Figure 3: Lab Setup [4]- The main coils (in green) provide the large holding field, H_0 , and the RF coils (red) provide the oscillating H_1 field. Laser light comes in through a window in the oven to polarize the cell, and the photodiode picks up light emitted by the atoms in the cell. The other coils pick up currents from the changing magnetic field in the cell, used for NMR measurements.

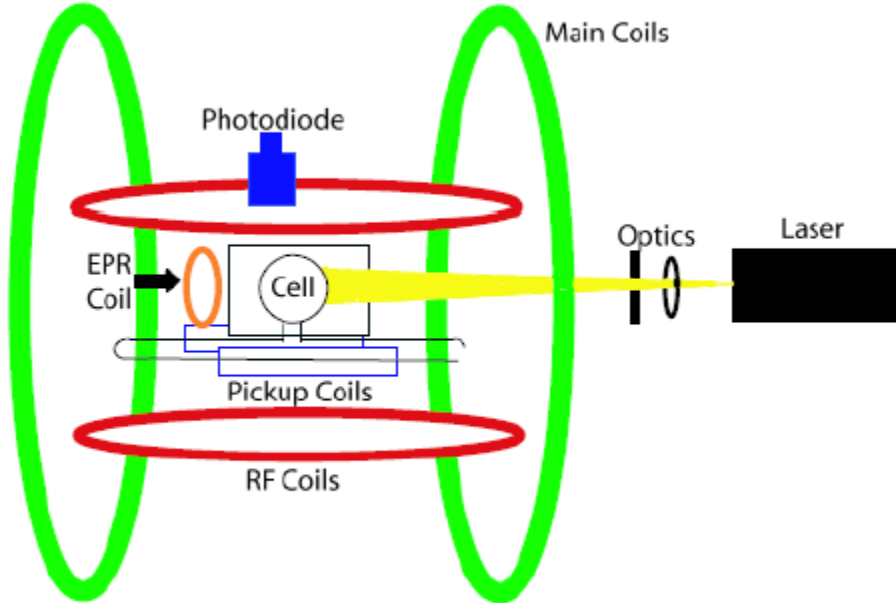

and we start NMR measurements to measure the polarization of the ^3He nuclei as they are slowly polarized. At this point we perform EPR studies on the cells to determine the absolute polarization. Then the cells are cooled back down to room temp and NMR spin down measurements are taken for approximately a day, from which we can calculate the lifetime of the cell.

2.3 Nuclear Magnetic Resonance

To measure the relative polarization of the cell, we use nuclear magnetic resonance (NMR). In a magnetic field, B , a charged nuclei follows equation 4, the energy of a magnetic moment, where μ is the magnetic moment and U is the energy.

$$U = -\vec{\mu} \cdot \vec{B} \quad (4)$$

The nuclei align themselves along the holding field. We then apply an oscillating magnetic RF field to the cell. In order to find the resonant frequency of the nuclei, it is possible to either fix the holding field B and sweep the RF frequency, or to hold the RF frequency fixed and change

the holding field. The holding field is the large field provided by the main coils in the system. In our lab we use a fixed RF frequency and sweep the holding field. As the field sweeps, the nuclei in the cell reverse orientation twice to align themselves with the field. The nuclei precess around the holding field at the Larmor frequency. As the nuclei spin, they induce a current in the coils around the oven, which we can then measure [2].

2.4 Electron Paramagnetic Resonance

There are different types of Electron Paramagnetic Resonance (EPR) which use the photons emitted from the atoms in the cell to determine the polarization. The emitted photons from the rubidium atoms come at two different frequencies, D1 and D2[2]. The first (D1) is from the $P_{1/2} \rightarrow S_{1/2}$ transition at the same frequency used for optical pumping and is therefore not very useful because measuring a minute amount of the emitted D1 light from the rubidium would be drowned out by the D1 light coming directly from the lasers. The second, D2, from the $P_{3/2} \rightarrow S_{1/2}$ transition, is not used by the optical pumping lasers and is therefore more easily measured. The amount of D2 light emitted increases at resonance. The first type of EPR is an amplitude modulation (AM) sweep, where the holding field is swept over from approximately 20 G to 28 G with a fixed RF frequency. This allows us to find the absorption peaks given by equation 5, where H_0 is the holding field and A_0/A_1^2 is the peak amplitude. AM sweeps allow us to calculate the relative concentration of each alkali in the cell by comparing the area under the peaks. The second type of EPR is frequency modulation (FM) sweep, in which the holding field is held constant while the RF frequency is changed, allowing us to lock onto resonance [4]. The FM sweep gives the derivative of the AM sweep. In the AM sweep we see peaks, whereas in the FM sweep the derivative of the peak is zero, which is much easier for the electronics to lock on to.

$$L(H) = \frac{A_0}{(H - H_0)^2 + A_1^2} \quad (5)$$

Once we are locked onto the resonant frequency, we can use Adiabatic Fast Passage (AFP) sweeps. The ^3He atoms precess around the holding field at the Larmor frequency. The RF frequency can then be changed, causing the spins to flip direction, and thus giving us a different resonant frequency. Measuring this change in frequencies allows us to calculate the polarization of the cell.

Figure 4: An example of an AM sweep

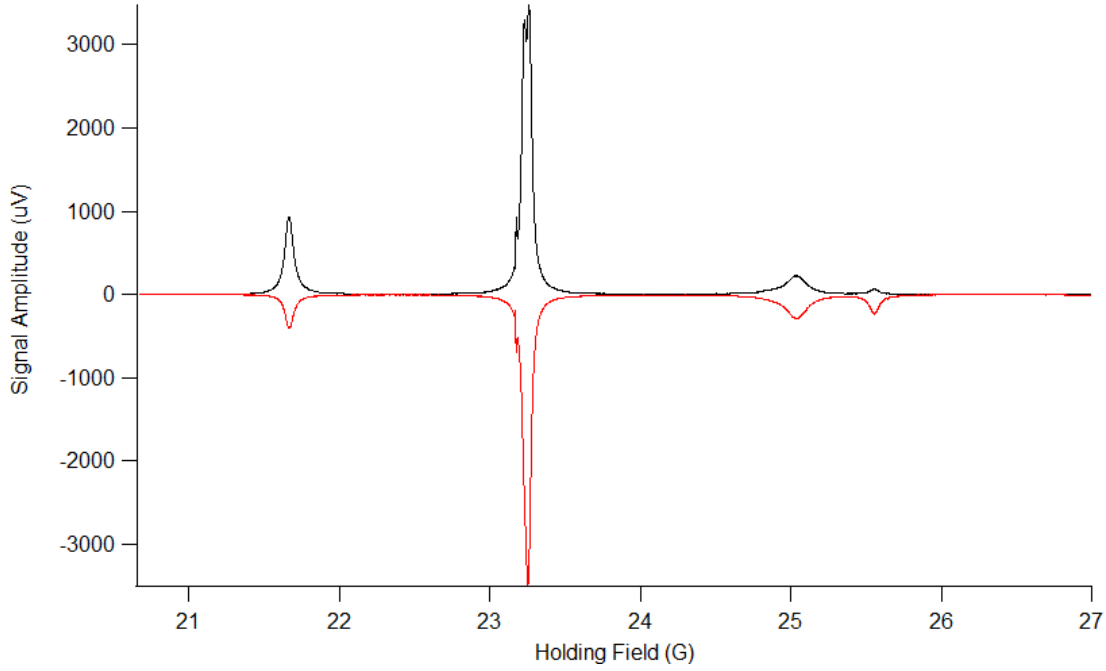

The resonant frequency changes due to the small effect of the magnetic field created by the polarized ^3He . In effect, the total magnetic field in one direction follows equation 6, while when the spins are flipped, the total magnetic field follows equation 7. H_0 is the holding field, $H_{^3\text{He}}$ is the field due to the polarized ^3He , and H is the total field.

$$H = H_0 + H_{^3\text{He}} \quad (6)$$

$$H = H_0 - H_{^3\text{He}} \quad (7)$$

The change in frequencies can then be related to the polarization of the cell by equation 8, where κ_0 is the frequency shift enhancement factor, which is proportional to the temperature, and P_{He} is the polarization of the cell [5].

$$\Delta\nu = \frac{d\nu(F, m)}{dH} \frac{8\pi}{3} \kappa_0 [^3\text{He}] P_{\text{He}} \quad (8)$$

Figure 5: An example of a FM sweep

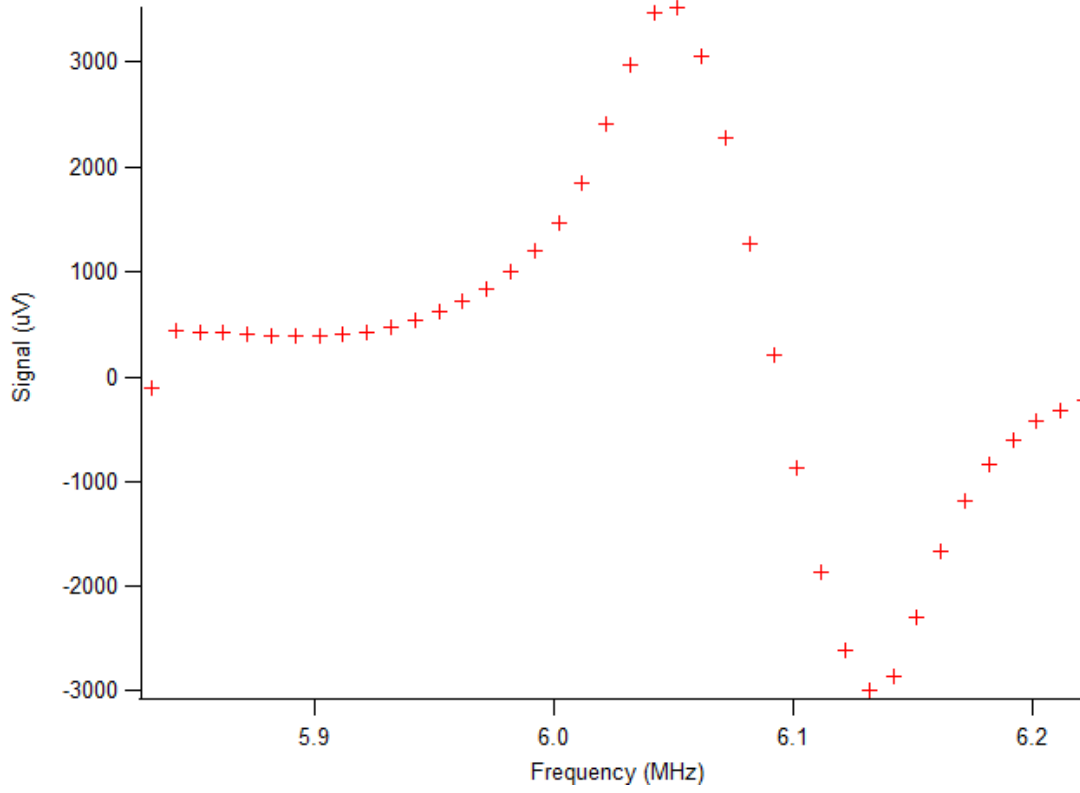
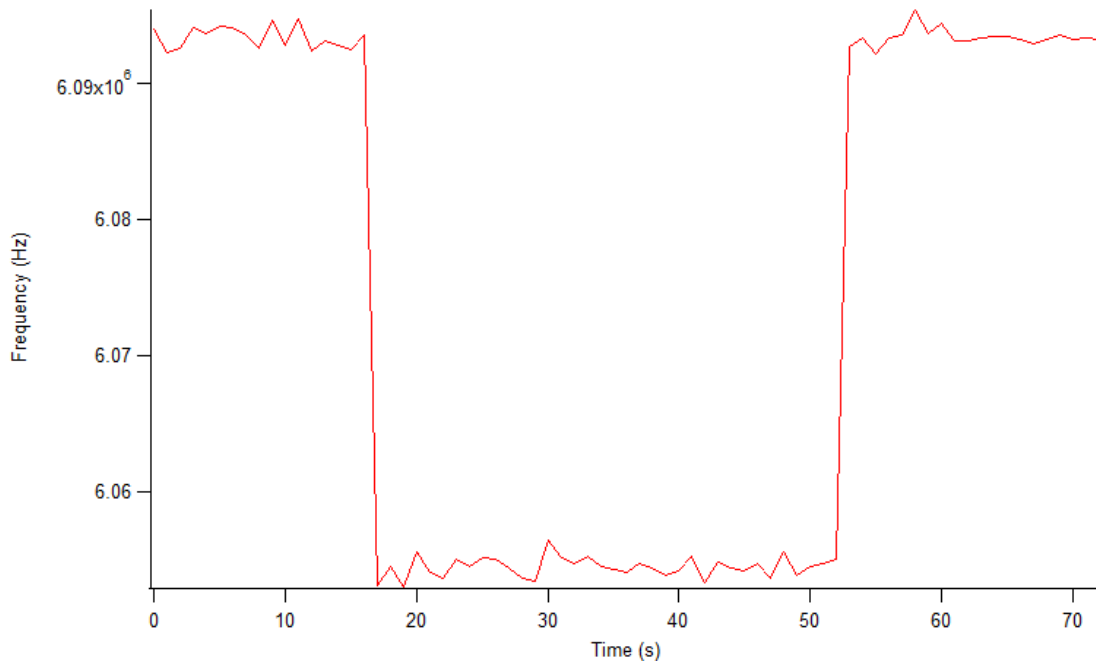

Figure 6: An example of an AFP sweep



2.5 Relaxation

Once the cell is polarized, it does not stay that way forever. The nuclei slowly relax and become depolarized due to a variety of factors. The relaxation rate is defined by three components: the relaxation due to collisions with other polarized ^3He particles (Γ_{dipole}), relaxation due to a magnetic field gradient (Γ_B), and relaxation due to collisions with the glass cell (Γ_{wall}).

$$\Gamma_r = \Gamma_{dipole} + \Gamma_B + \Gamma_{wall} \quad (9)$$

The first two terms are relatively well-known and predictable. The relaxation due to collisions with the wall is however as of yet not well understood.

The first source of relaxation comes from dipole-dipole interactions between ^3He nuclei. This causes the loss of polarization to orbital angular momentum through the magnetic dipole interaction. For an average 10 amg cell (an amagat is the number of molecules per unit volume at 1 atm of pressure and 273.15 K), $\Gamma_{dip} = 3 \times 10^{-6} \text{ s}^{-1}$ at room temperature. The second source of relaxation comes from magnetic field gradients in the cell.

$$\Gamma_B = D_{He} \frac{|\vec{\nabla} B_x|^2 + |\vec{\nabla} B_y|^2}{B_z^2} \quad (10)$$

Where D_{He} is the self-diffusion coefficient ($= 0.19 \text{ cm}^2/\text{s}$ at room temperature), and B_x, B_y, B_z are the magnetic fields in the x,y, and z directions. As stated before, the third factor affecting the relaxation time are collisions with the wall of the cell. The wall relaxation comes from a variety of factors, including paramagnetic impurities in the glass, contaminants on the glass surface, and microfissures in the glass surface.

There are then two important relaxation times. τ_1 is the longitudinal relaxation time, which is the lifetime of the cell. The second relaxation is the τ_2 , the transverse relaxation time. The longitudinal relaxation time is equal to the inverse of the relaxation rate, or $\tau_1 = 1/\Gamma_r$. Typically the relaxation rate is dominated by the dipole-dipole relaxation and the relaxation due to the wall collisions. In other words, $\frac{1}{\Gamma_B + \Gamma_{wall}}$ is approximately 20-60 hours depending on the cell. The relaxation due to the magnetic field gradients is usually small compared to the other two (provided the experiment is run well, with the cell in an area largely without a field gradient).

Figure 7: String containing two cells, Calvin and Hobbes, with cell dimensions for the glassblower

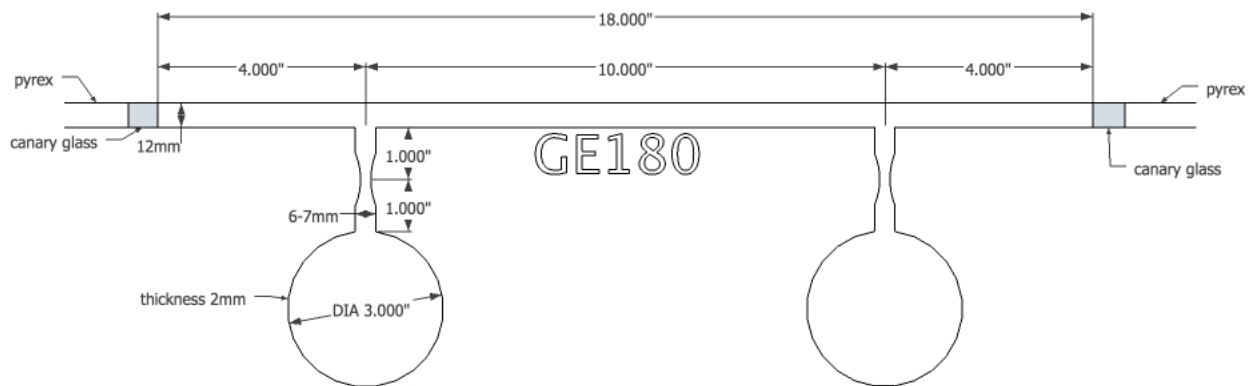

3 Experiment

The first step in filling and analyzing a cell is to have it created by a glassblower. A diagram is sent to a glassblower, who then creates the cell and sends it to us. The diagram for our first two cells, Calvin and Hobbes, is shown in Figure 7. Once we receive the cell string, it is connected to the vacuum system in the lab. Ampoules of rubidium and potassium are connected to the string and the entire string is then cleaned and pumped. The next step is to accurately measure the volume of the two cells. This is done by filling N_2 gas into two areas of known volume, and then through the cell. At each step we can measure the pressure and get an accurate volume measurement, which is used to calculate the density of each cell. The density is then used to calculate the polarization.

Once the cells have been cleaned and the volume measured, we then use the breakseal ampoules

of rubidium and potassium. We break the glass seal with a magnet and steel "hammer" encased in glass, and then heat the alkali metal, moving the gas into the cell. We make sure to move only alkali metal vapor to distill the alkali metal, ensuring that we only have pure alkali metal in the cell. Once the alkali metal has been added, we then add the nitrogen and helium gas to the cell. The cell is cooled to 4 K to trap the gas in it as we use a torch to heat up the pulloff (area between cell and string) and remove the cell, making sure it is sealed. At this point we now have an unpolarized cell, and the filling is done and the polarization and lifetime experimentation can begin.

4 Glass Studies

Working in collaboration with Olga Trofimova at Jefferson Lab, we were able to cut open some cells and try to get a better idea of whether the glass is affecting the lifetime of the cell. We first cut up a piece of a very old cell that had alkali metal in it and had been exposed to the air for quite some time. Olga was able to produce the following x-ray fluorescence (XRF) analysis from the cell in Figure 8. We also sent Olga some samples from glass that was blown into a cell but then immediately cut up, never having been used for actual tests and thus never coming into contact with any alkali metal. This spectrum is in Figure 9.

We can then compare the spectrum with what we know is in the glass, in Figure 10.

There are a couple elements we see because of the background due to the XRF machine itself, namely argon, nickel, iron, and rhodium. The background XRF spectrum is in Figure 11. The only questionable element we see is palladium. All other elements are expected in the glass. Ultimately it is hard to come to any conclusions, but in the future with better samples this analysis may be very helpful to determining whether the glass is becoming contaminated and affecting the cells. Using the pristine glass again, Olga was able to produce a variety of scans using atomic force microscopy (AFM).

Figure 8: XRF analysis of old target

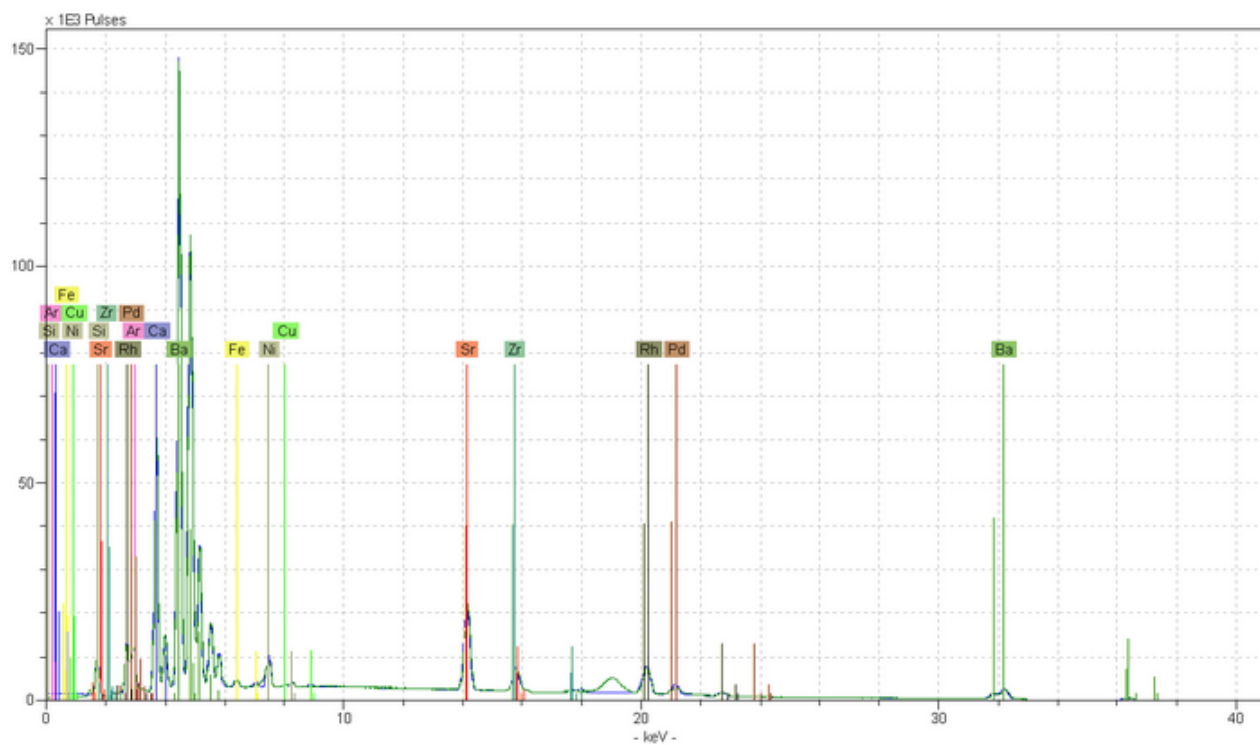

Figure 9: XRF analysis of pristine target

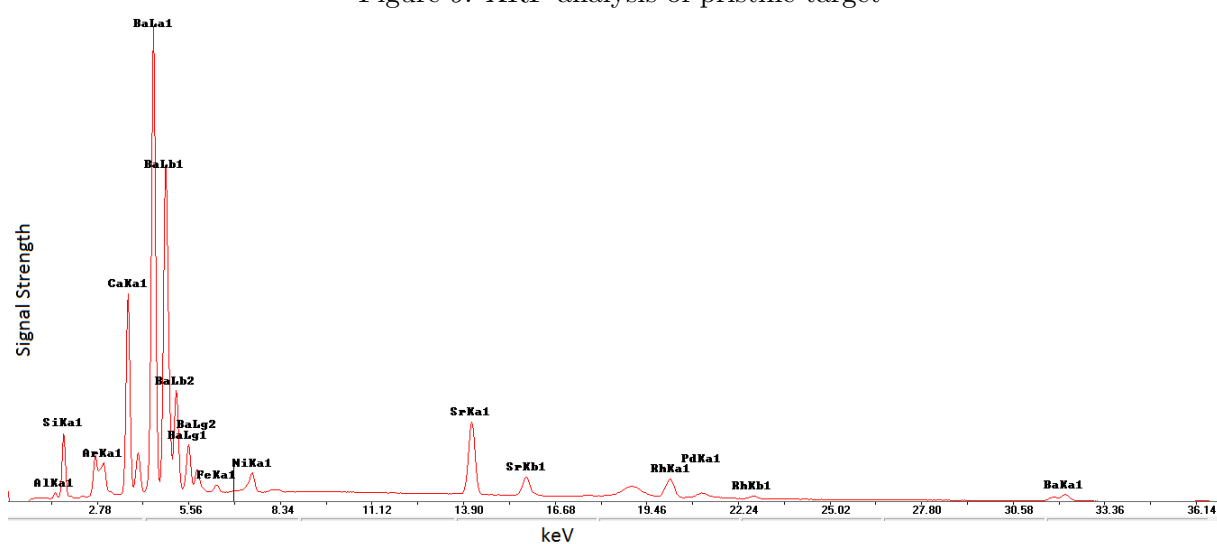
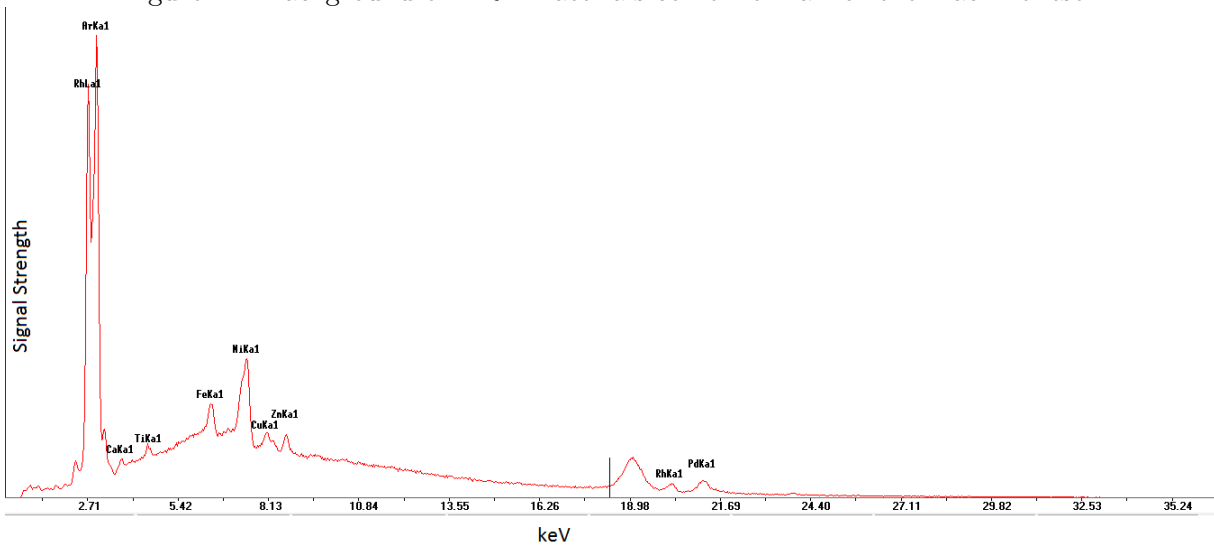

Figure 10:

GE180 Aluminosilicate Glass Composition	
Molecule	Composition by weight
SiO ₂	60.3%
BaO	18.2%
Al ₂ O ₃	14.3%
CaO	6.5%
SrO	0.25%

Figure 11: Background of XRF-materials come from air or the machine itself



The AFM has a resolution limited by the tip, usually around 10-20 nm. On that scale, the glass seems to be extremely flat. There are differences in height of around 10 nm on the scans, but they are extremely wide peaks or troughs. So from the AFM at least, it appears the glass is extremely good quality. There are seemingly no microfissures or features that would trap atoms.

Figure 12: AFM scan of pristine glass. Highest peak is about 0.6 nm tall and 120 nm wide. No fissures are seen.

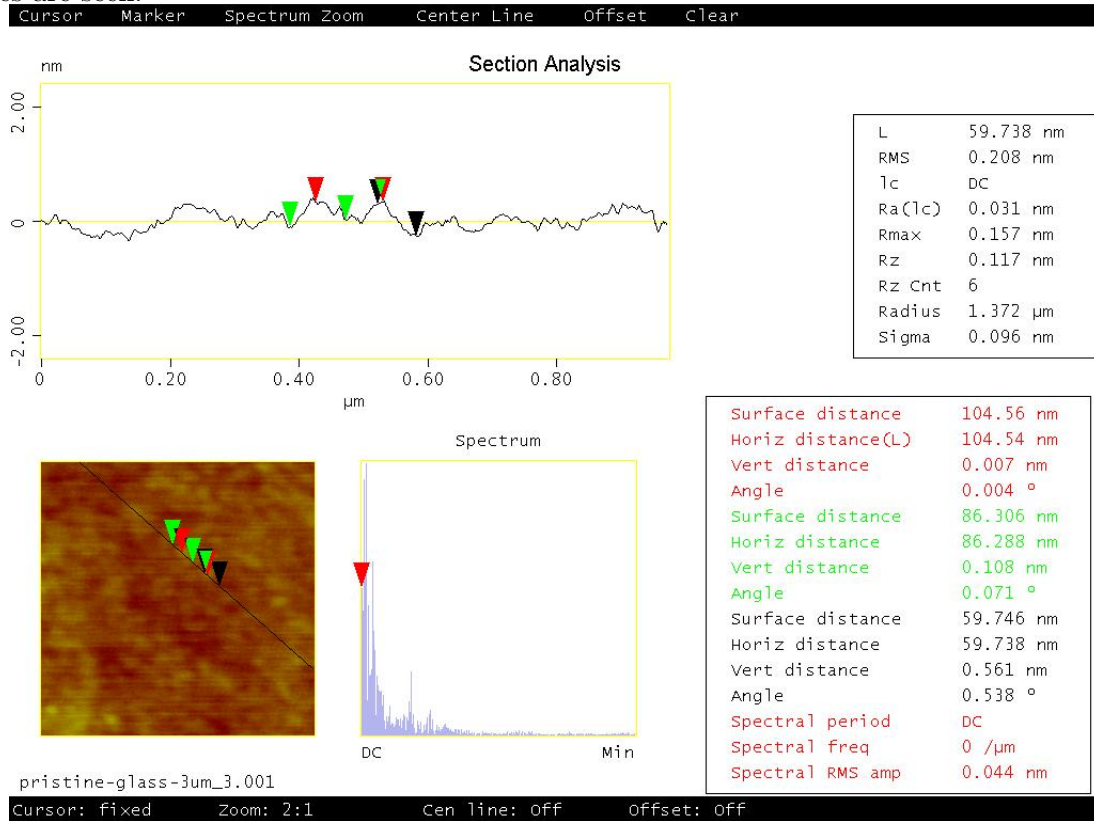

We also did similar analysis on another cell, Hobbes, which was a hybrid cell that we cut open to study the glass surface after it had come into contact with alkali metals. The surface is slightly rougher, but is still quite smooth and would not be able to trap any atoms and cause them to lose their polarization.

Figure 13: AFM scan of hybrid cell glass. Highest peak is about 1.7 nm tall and 150 nm wide. No fissures are seen.

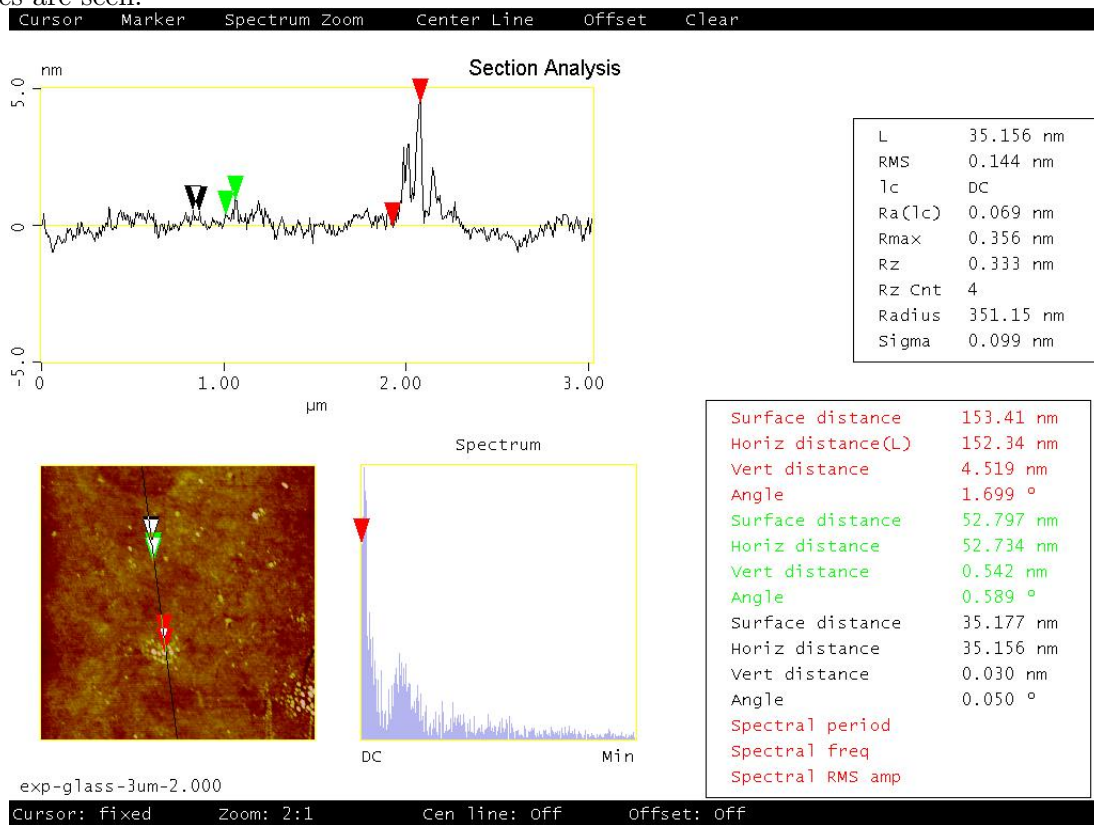

5 Results

In the fall we looked at three different cells—Calvin, Hobbes, and Mini. For the first, Calvin, we filled the cell with only rubidium. The cell was then heated to 180°C and we turned on two narrowed lasers at D1 frequency. After taking the NMR spin up measurements, we took EPR measurements and found that the cell had a EPR frequency difference of 65 kHz which gave us a polarization of 55%, which is relatively standard for a non-hybrid cell. After taking NMR spin down measurements, we found that the cell had a lifetime of around 3.76 hours. The equation for the polarization during spin up and spin down measurements is given by equations 11 and 12 respectively. For spin down measurements, $\gamma_{SE} = 0$ as the cell is no longer being polarized, and simplifies to equation 12, as, $P_0 = P_{max}$. Thus for the spin up plots, the lifetime $\tau = \frac{1}{\Gamma_r + \gamma_{SE}}$, and for spin down the lifetime $\tau = \frac{1}{\Gamma_r}$.

$$P(t) = P_0 e^{-(\Gamma_r + \gamma_{SE})t} + \frac{\gamma_{SE}}{\Gamma_r + \gamma_{SE}} \quad (11)$$

$$P(t) = P_{max} e^{-(\Gamma_r)t} \quad (12)$$

Figure 14: NMR Spin Down on Calvin- Each measurement was taken thirty minutes apart, so the lifetime is equal to tau divided by two. (3.75 hours). The data is fit to the equation $P(t) = y_0 + Ae^{t/\tau}$ where $A = P_0$.

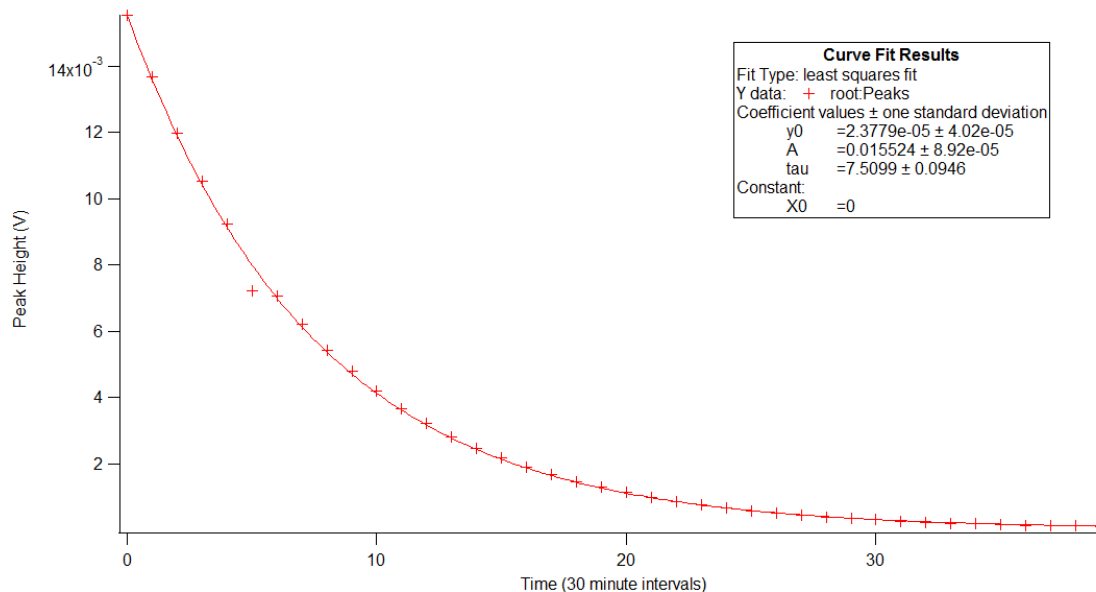

The second cell, Hobbes, is also a 3" sphere. We filled Hobbes with both rubidium and potassium, making it a hybrid cell. We followed a slightly different process this time in an attempt to increase the cell lifetime. The cell was heated to 204 °C, and then cooled back down. The cell was then heated up to the actual oven temperature at 230 °C, and two narrowed lasers as well as one broad were turned on, again at D1. Once polarized by the lasers, we found through the EPR measurements that the cell has a polarization of 63% which is expected for a hybrid cell. After doing the NMR spin down measurements, we found a lifetime of 5.3 hours, which again was short.

Figure 15: NMR Spin Down on Hobbes, lifetime 5.25 hours

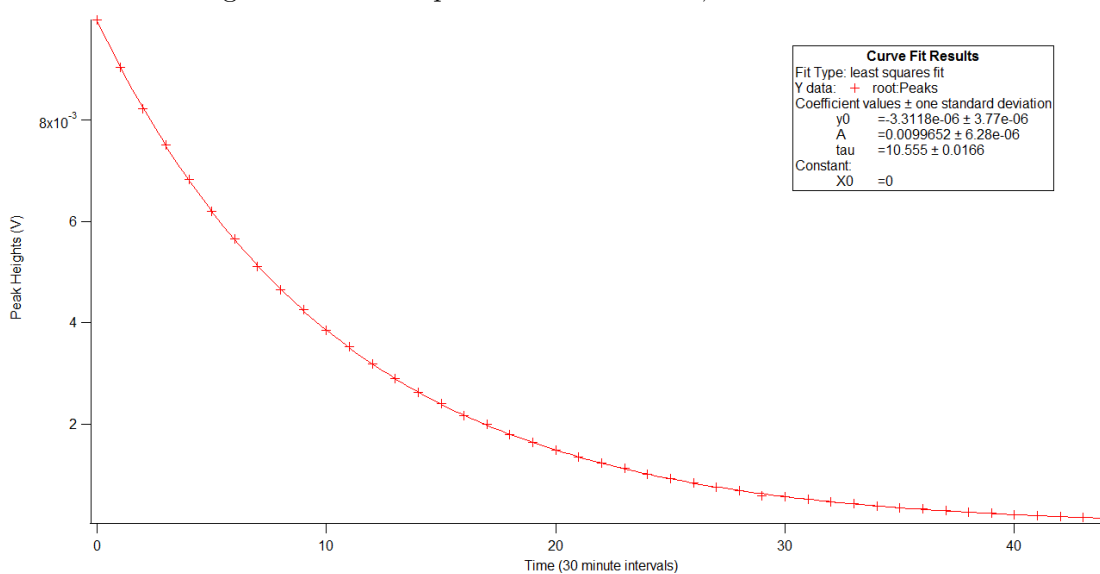

The final cell we worked on last semester was Mini, a cell sent to us by Duke University to fill and polarize. Mini is an approximately 1" sphere connected by a very small transfer tube to a 2" long cylindrical target. The cell was filled with both rubidium and potassium and then heated to 190 °C and NMR spin up measurements were performed. The EPR measurements at 190 °C yielded a frequency difference of around 16 kHz which was very small, so we increased the temperature to attempt to get a larger polarization. We then heated the cell to 200 °C and measured a frequency difference of 18 kHz. At 210 °C we then measured an indiscernible difference. Ultimately we measured a polarization of only 26% in the cell, and found a lifetime of only 1.8 hours. After the measurements, Professor Averett noted that due to the incredibly small diameter of the tube between the cell and target tube, the alkali metal had condensed in the transfer tube

and was presumably blocking the cell from effectively being polarized, especially in the lower target tube which is used for the actual collisions at Jefferson Labs. Unfortunately this somewhat limited the usefulness of the cell.

Figure 16: NMR Spin Down on Mini, lifetime 1.8 hours

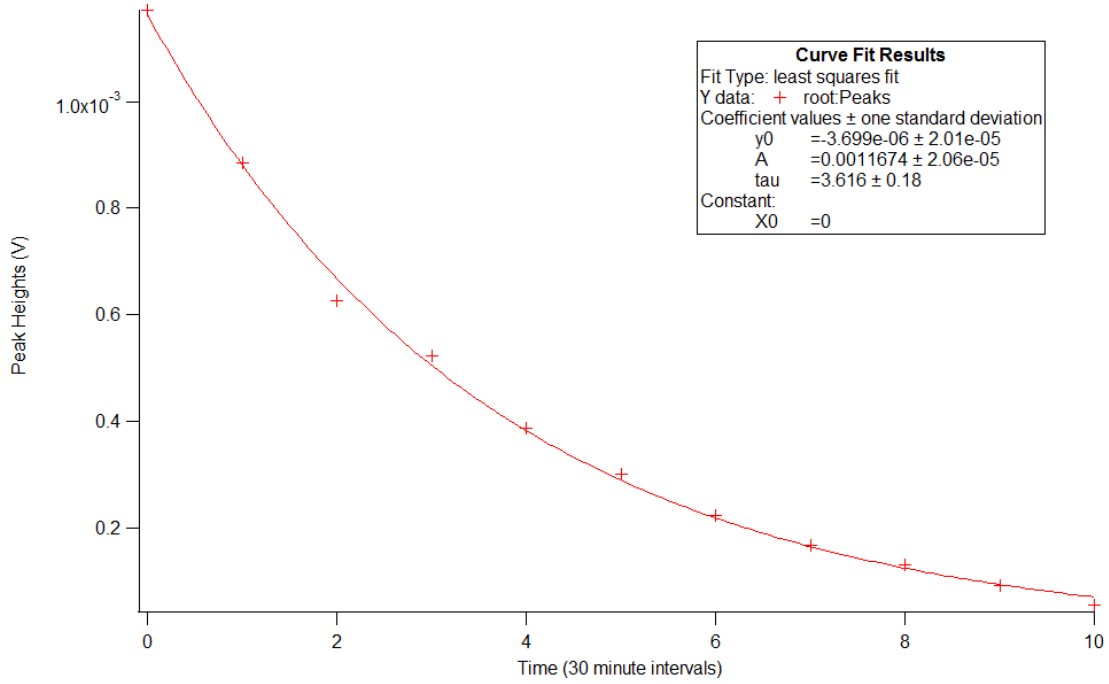

For the first cell tests of 2015, we reused an old cell that had good results, Gloucester. Gloucester had previously been found to have a lifetime of around 70 hours, so testing it would theoretically allow us to test whether the lab setup itself is somehow making worse cells than before. From the NMR spin up and down data, we see that Gloucester has a significantly shorter lifetime than had been measured previously (70 hours previously, now 7-12 hours). This may be due to the fact that the cell has simply degraded since first being tested, or we may be correct in thinking that there is some systematic problem in the NMR and EPR processes that somehow is causing the cell lifetimes to decrease. We did find, however, that as Kelly Klutz's [5] thesis suggests, raising the holding field from 13 G to 21 G increased the lifetime of the cell from about 7 hours to about 12 hours. A lifetime of 12 hours is still extremely small in comparison to previous good cells, but the increase from 7 to 12 hours is definitely helpful.

Figure 17: NMR Spin Up on Gloucester

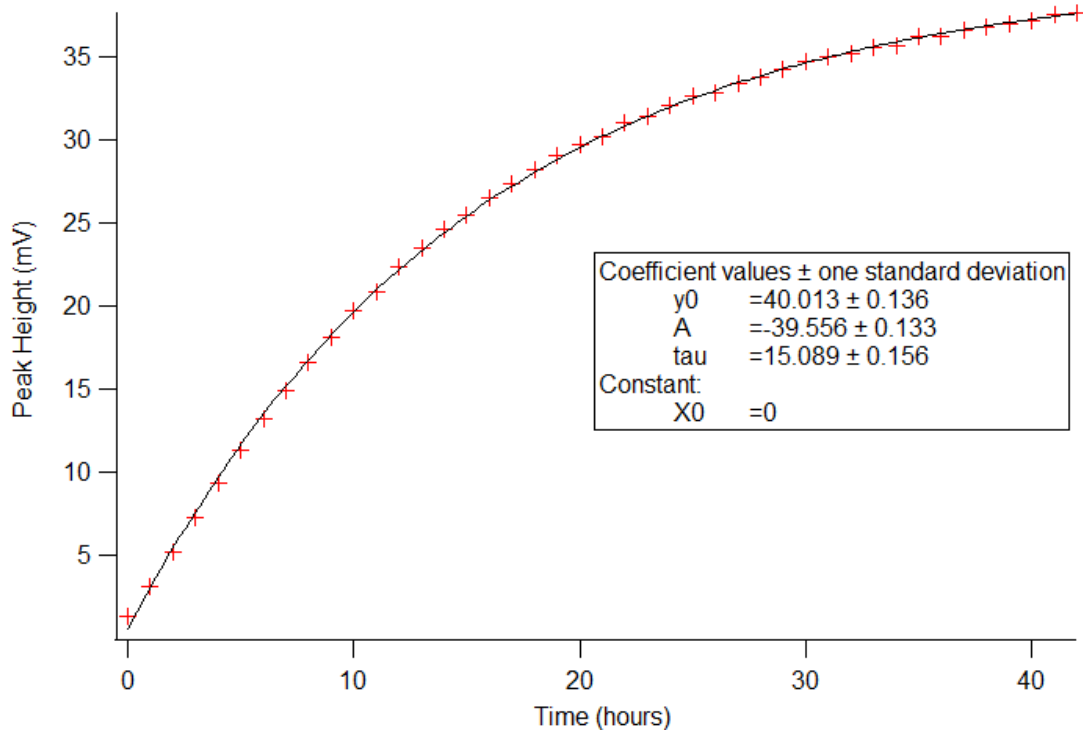

Figure 18: NMR Spin Down on Gloucester-Holding field at 13 G, lifetime 7.5 hours

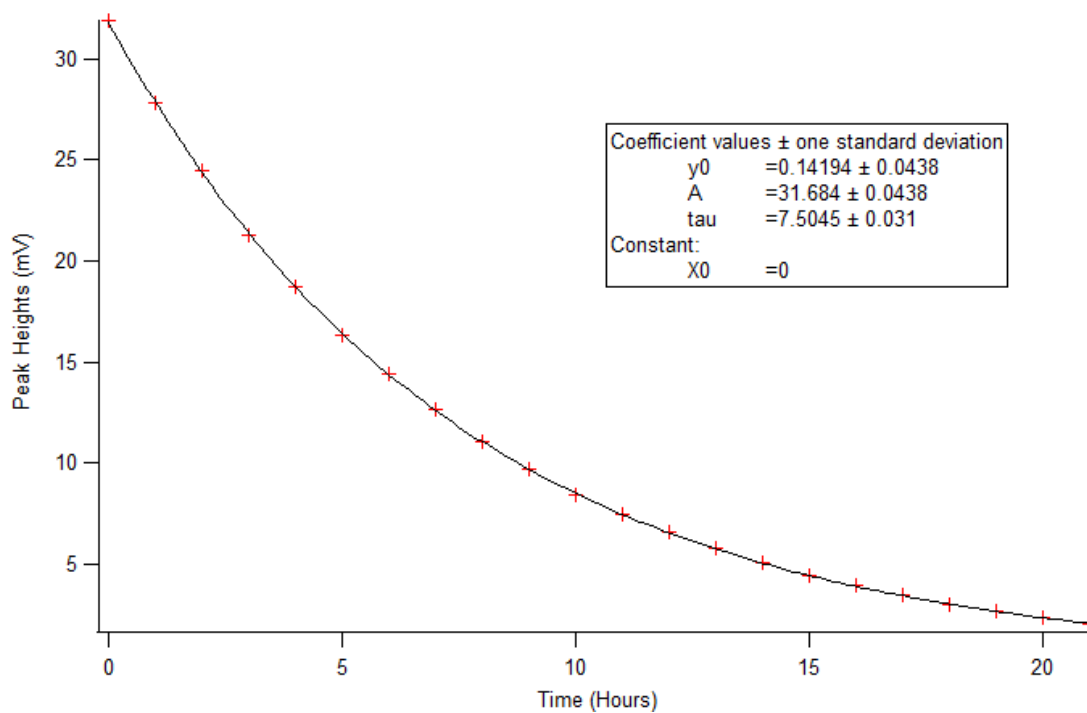
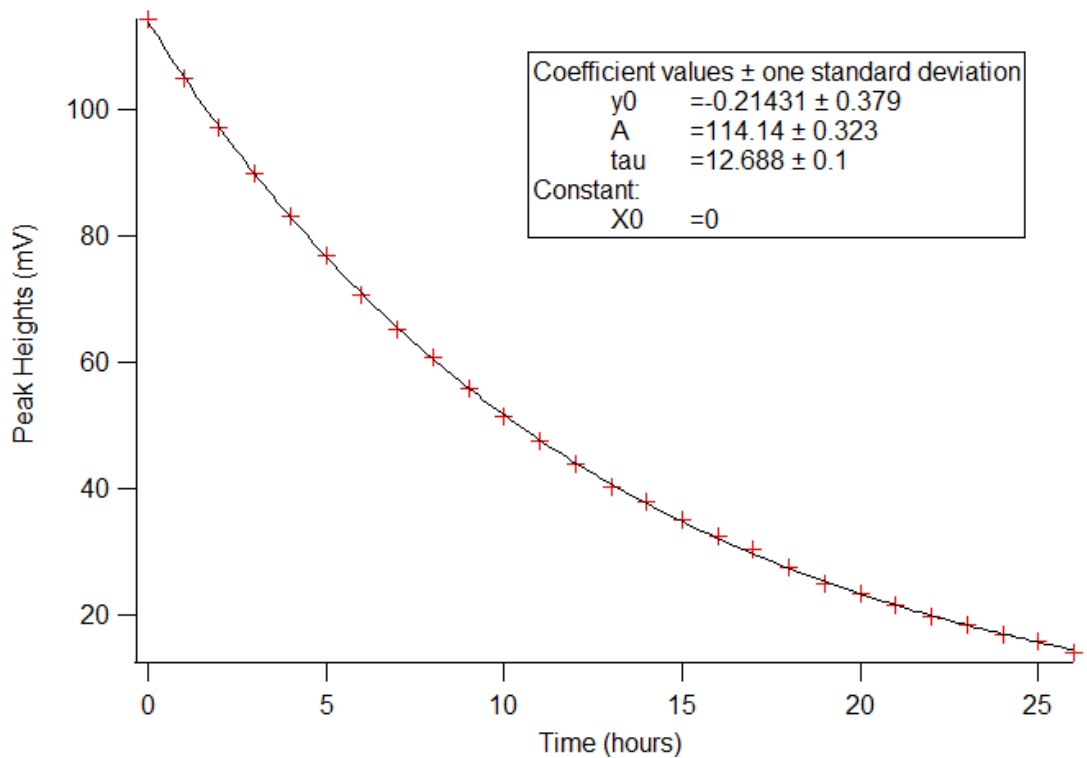

Figure 19: NMR Spin Down on Gloucester-Holding field at 21 G, lifetime 12.7 hours



After looking at Gloucester, we tested two newly filled cells, Worm and Caterpillar. Both are 3.5" spheres. Caterpillar was filled only with rubidium; Worm is a hybrid cell. We used a new stainless steel coil immersed in a dewar filled with liquid nitrogen to clean the gas of impurities. We did not use the old commercial getter (a mechanism used to clean the gas), as we feared that despite its ability to remove water and other gases, it may have been introducing other metal impurities to the system. The new liquid nitrogen getter freezes out any impurities in the gas that freeze above 77 K, hopefully improving the purity of the system. The new tubing getter was used with liquid nitrogen this time, but in the future may be used with liquid helium to clean the gas even more effectively. The first cell we tested was Caterpillar and we got a lifetime of around 33 hours with a holding field at 21 G. However, upon repolarizing the cell and changing the holding field to 13 G, we found a lifetime of only 21 hours. Finally, setting the holding field to 30 G, we obtained a lifetime of 37 hours. From these lifetimes, there is definitely a correlation between the holding field and lifetime of the target cell.

Figure 20: NMR Spin up on Caterpillar

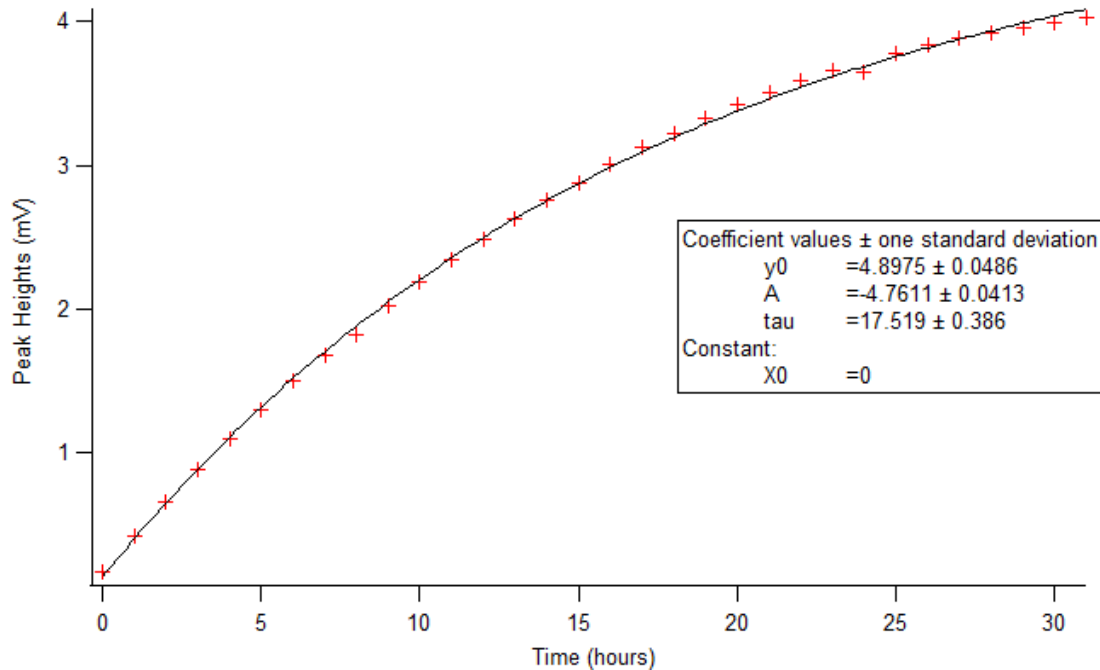

Figure 21: NMR Spin Down on Caterpillar, holding field at 21 G, lifetime 33.6 hours

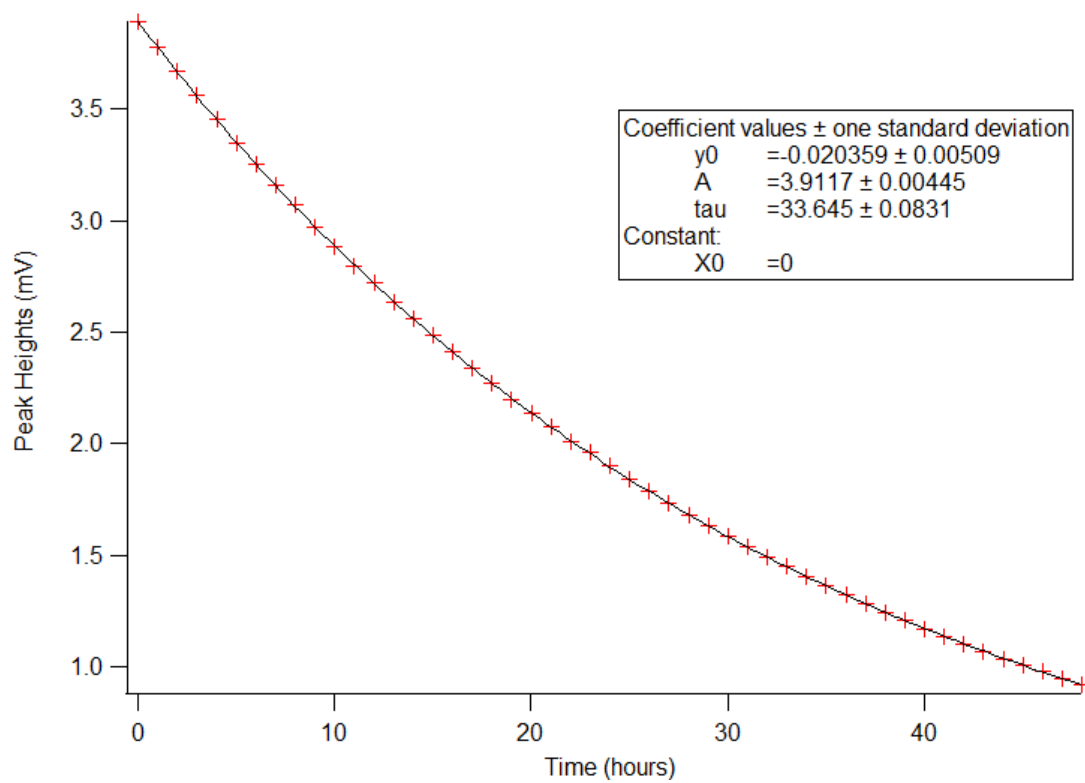

Figure 22: NMR Spin Down on Caterpillar, holding field at 13 G, lifetime 20 hours

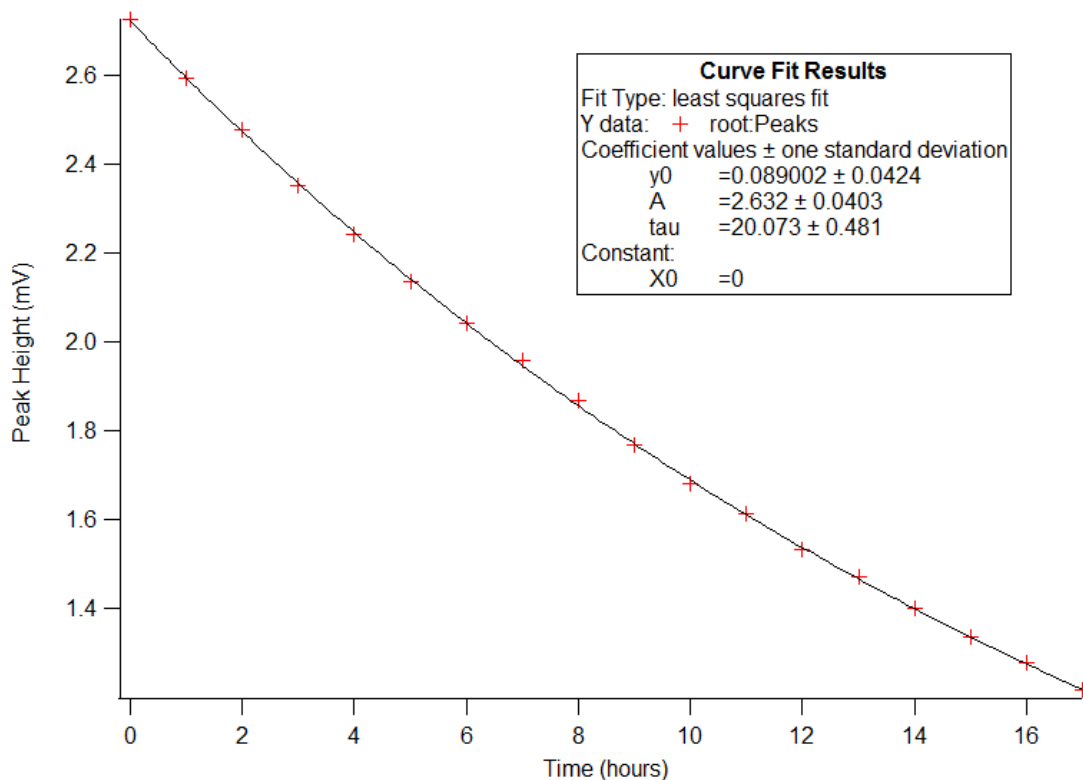
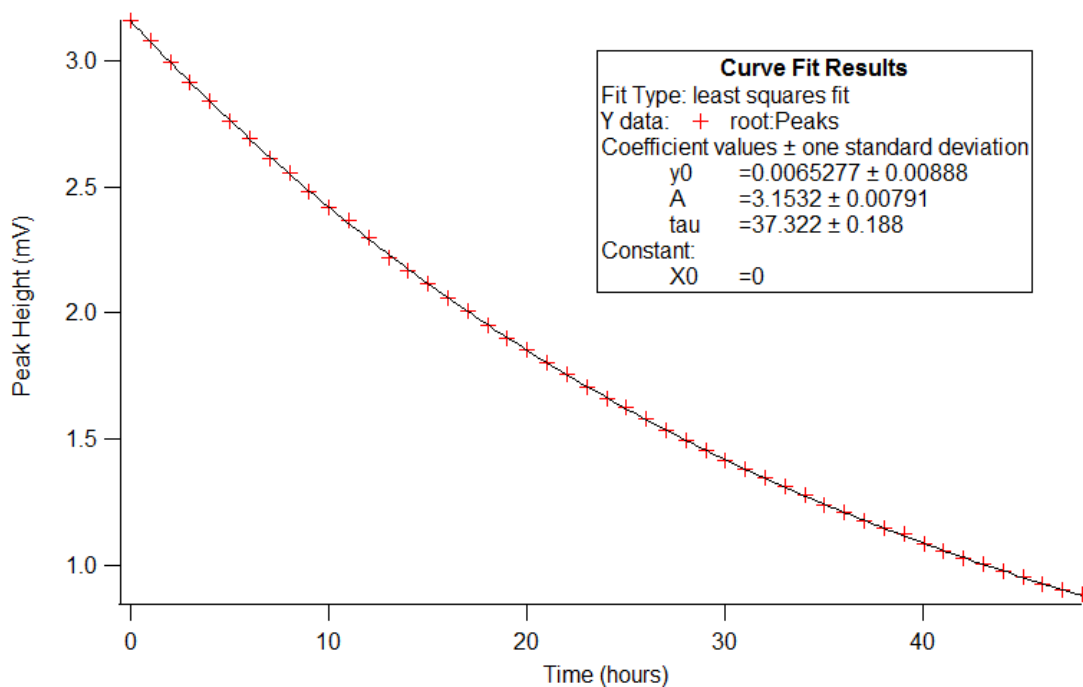

Figure 23: NMR Spin Down on Caterpillar, holding field at 30 G, lifetime 37 hours



The final cell of the semester was Worm, a hybrid cell, also 3.5" in diameter. Worm was filled with the same process at Caterpillar, and yielded similar results, with a lifetime of around 24 hours.

Figure 24: NMR Spin Up on Worm

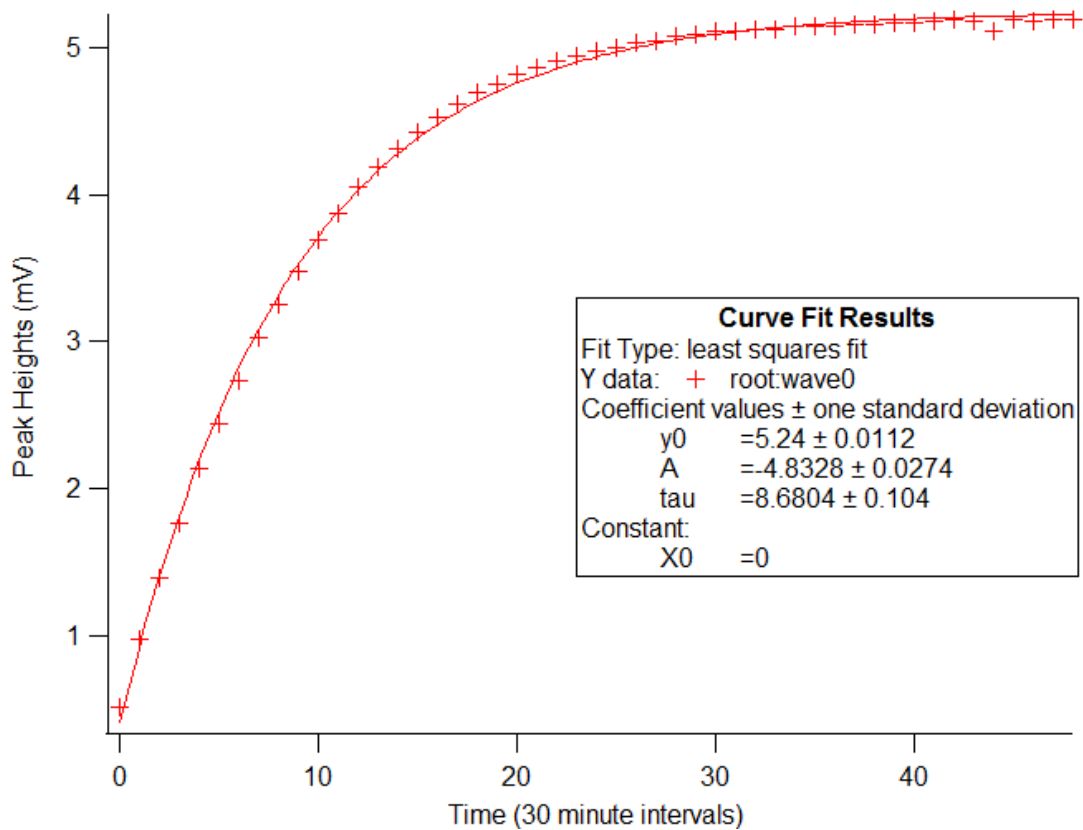

Figure 25: NMR Spin Down on Worm, holding field at 30 G, lifetime 24 hours

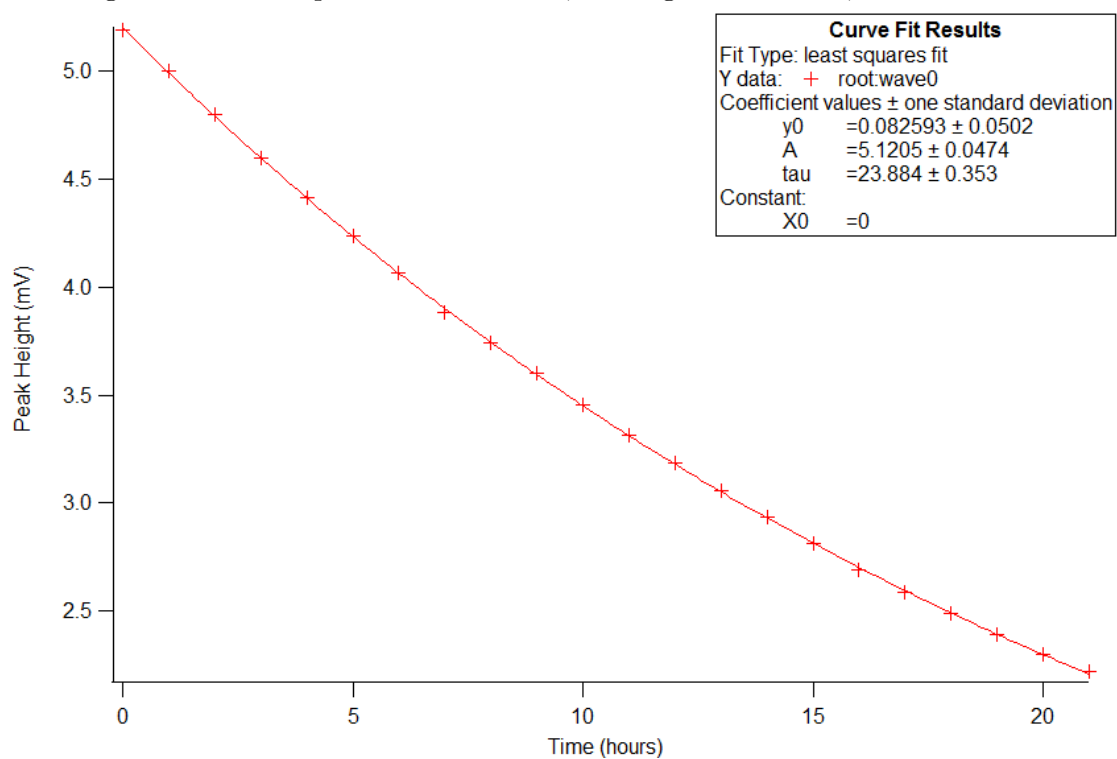

Table 1: Table of results from all 6 cells tested this year (S/V is the surface to volume ratio)

Name	Glass Type	Shape	S/V (mm^{-1})	Lifetime (hrs)	Polarization
Calvin	GE180	3" sphere	0.079	3.76	55%
Hobbes	GE180	3" sphere	0.079	5.3	63%
Mini	GE180	1" sphere+transfer tube	0.311	1.8	26%
Gloucester	GE180	3" sphere	0.18	12	46%
Caterpillar	GE180	3.5" sphere	0.067	33.6	
Worm	GE180	3.5" sphere	0.067	23.8	

6 Conclusions

Ultimately we did not come to any definitive conclusions regarding increasing the lifetime of future cells, but we did manage to improve the new cell lifetimes due to a few factors. One of the first things we looked at was creating a rubidium only cell. This cell, Calvin, had a short lifetime of about 3.76 hours.

The next thing that we tried was to heat a hybrid cell, then let it cool, before again heating it and polarizing the cell in the hopes that this would help to decrease the amount of interactions with the glass, and increase the lifetime of the cell. We did this with our second, Hobbes, a hybrid cell. Hobbes had a lifetime of approximately 5.3 hours, which was low for hybrid cells, and so was ultimately inconclusive.

There are a large number of factors at play for every cell we create, and therefore it is difficult to nail down every variable. Filling and analyzing a cell is time-consuming work, and we can only test a few cells in one semester. We worked on a few things in between semesters, the first of which was a spreadsheet of all previous cells. This catalogue of previous cells allows us to look at what we have done in the past and if applicable, what resulted from those cells. One of the conclusions we drew from the spreadsheet was that almost all cells created since Professor Averett moved labs in 2010 have had poor lifetimes. What this is caused by is uncertain. We first entertained the idea that the new lab has electromagnetic noise that is causing the cells to lose polarization. We found a signal with frequency of around 44.5kHz in the lab, and determined that it was coming from the fluorescent lights. We tested the lifetime of Caterpillar with and without the lights on and found no difference, so the fluorescent lights do not seem to have an effect. We did not find anything else, but it is also possible that in the new lab the coils are slightly misaligned, creating a field gradient that kills the polarization of the cell. This spreadsheet is included in the appendices.

The second change we made this semester was a new series of tubing we connected to the vacuum system. This coil of stainless steel was placed inside a dewar where it was cooled to around 77 K to clean the gas even more efficiently than just the commercial getter. The getter uses a metal mesh to catch unwanted particles as the gas flows through. The cold tubing will help as when cooled to that low of a temperature, particulates like water freeze and drop out of the gas. Our first cells constructed with the new tubing, Worm and Caterpillar, showed promising results.

Caterpillar is a rubidium only cell that was tested and found to have a lifetime of 33 hours at 21 G holding field. This is an excellent step back in the right direction for cell lifetimes, and bodes well for future cells created in the lab. We also noticed from measurements on Caterpillar that the holding field has a definite effect upon the lifetime. With a smaller holding field, 13 G, we measured the lifetime of Caterpillar to be 20 hours. With a large holding field of 30 G, we measured a lifetime of 37 hours. We are not yet certain as to why the field strength and lifetime are correlated. One of the possible options is that increasing the holding field effectively decreases the effect of any external field gradients in the system, which depolarize the cell. A larger holding field may simply be drowning out the external gradients that may have affected previous cells. We tested Worm next, and got a lifetime of 23.8 hours at a 30 G holding field.

We also spent some time investigating the glass used in creating the cells. This data is included in the appendices. So far we have done some AFM scans of pristine (never been filled) cell glass. The AFM has a resolution of about 10-20 nm due to the size of the tip. On that scale the glass is extremely smooth, and seemingly contains no features that would be able to trap atoms and cause them to lose polarization. We then cut open and looked at Hobbes, a recently tested hybrid cell. We found similar results, with a slightly rougher surface, but overall still extremely smooth. We also did an XRF spectrum analysis of both the pristine glass and the hybrid cell. We saw mostly what we expected to be in the glass plus the background materials in the XRF machine itself. We did not however, see and rubidium or potassium on the surface of the hybrid cell. It is possible it got cleaned off in the process of doing the analysis. Hopefully in the future we will be able to utilize some other methods to scan the surface even more closely, ideally before the cell has been opened and the alkali metal reacts with the air. Unfortunately we have mostly just begun this work, and have not come to any real conclusions regarding the glass, but hopefully these studies will eventually give us a better idea of the effect the glass has on the lifetime of the targets.

7 Appendices

7.1 Glass Studies

Figure 26: AFM scan of first piece pristine glass, $3\mu\text{m} \times 3\mu\text{m}$

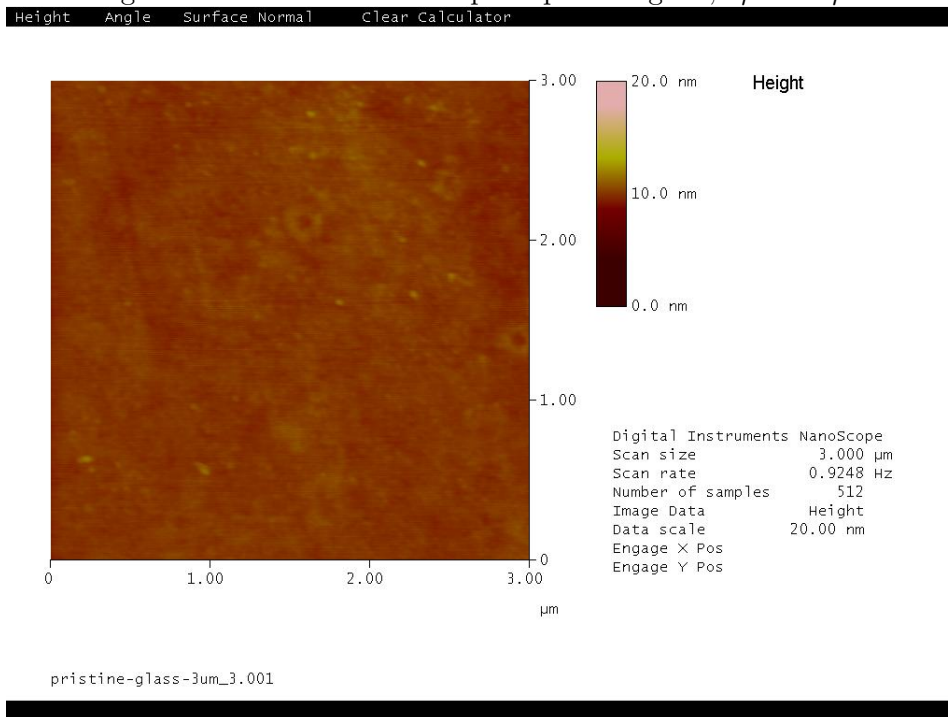

Figure 27: 3D AFM scan of the first piece pristine glass, $3\mu\text{m} \times 3\mu\text{m}$

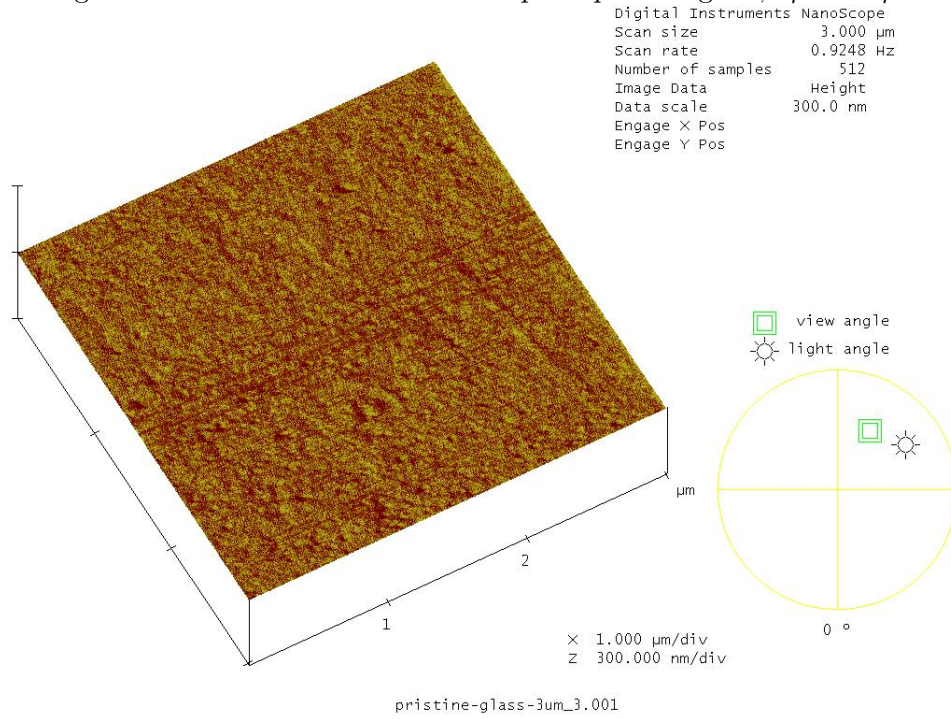

Figure 28: Roughness Analysis of AFM scan of first piece of pristine glass, $3\mu\text{m} \times 3\mu\text{m}$

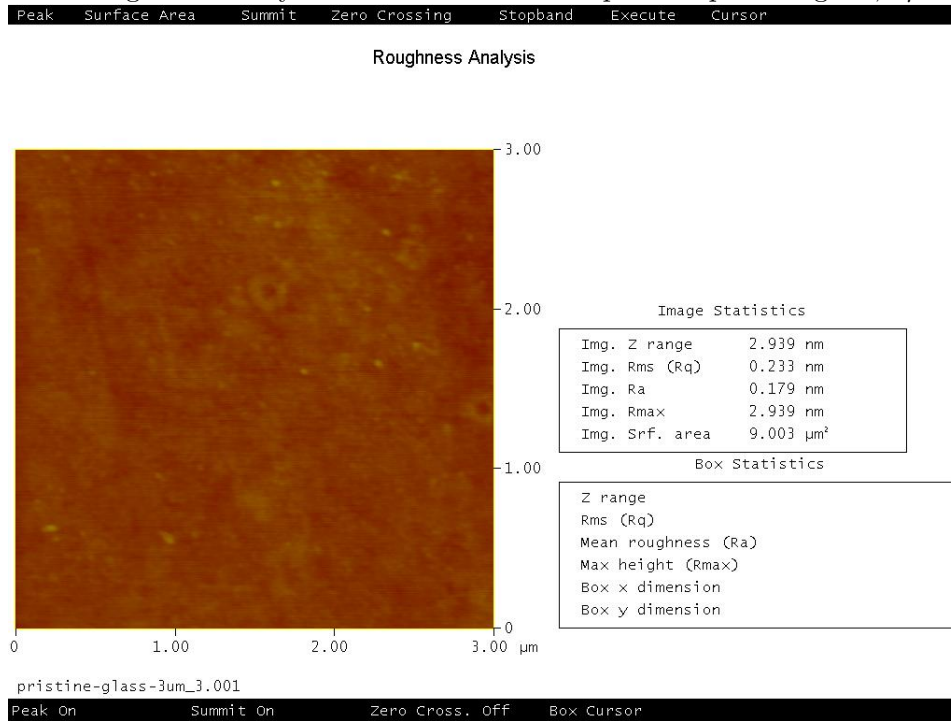

Figure 29: AFM scan of second piece pristine glass, $3\mu\text{m} \times 3\mu\text{m}$

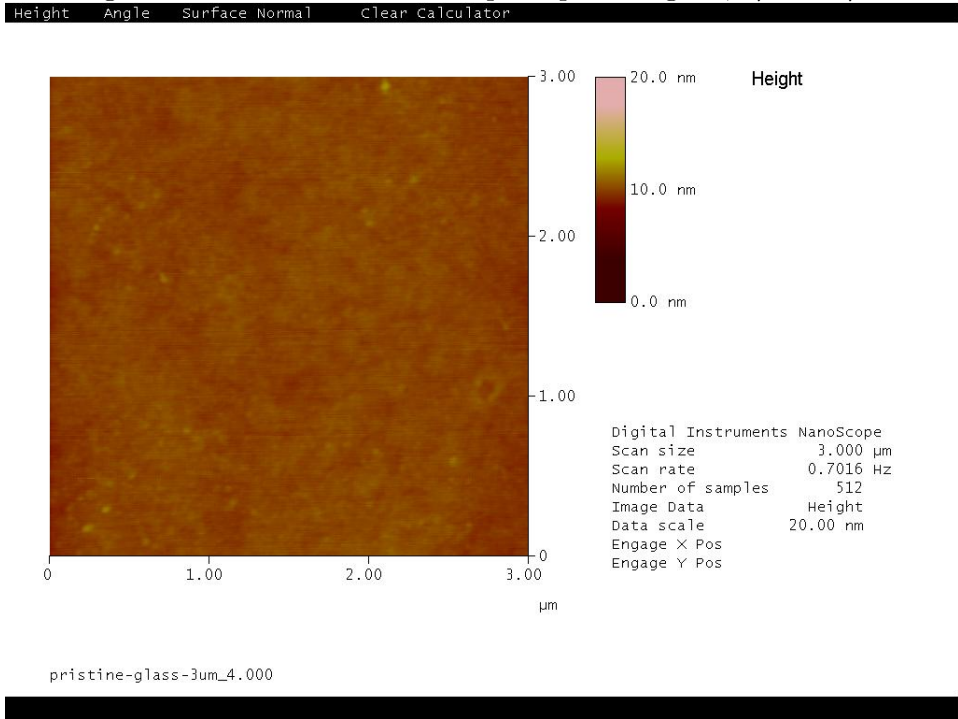

Figure 30: 3D AFM scan of second piece of pristine glass, $3\mu\text{m} \times 3\mu\text{m}$

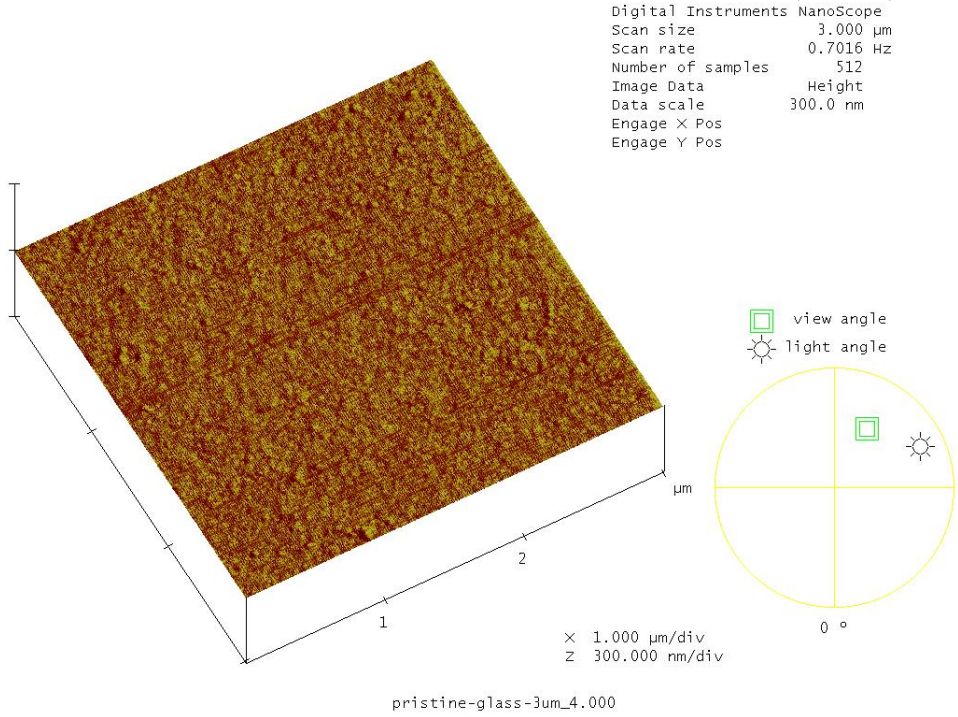

Figure 31: Roughness Analysis AFM scan of second piece of pristine glass, $3\mu\text{m} \times 3\mu\text{m}$

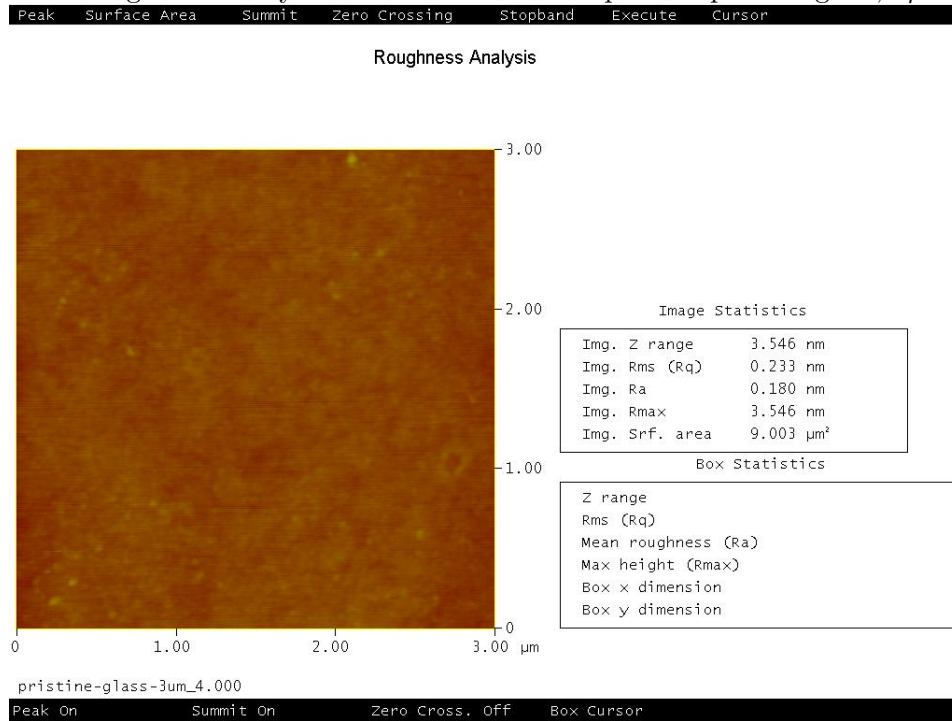

Figure 32: AFM scan of third piece of pristine glass, $5\mu\text{m} \times 5\mu\text{m}$

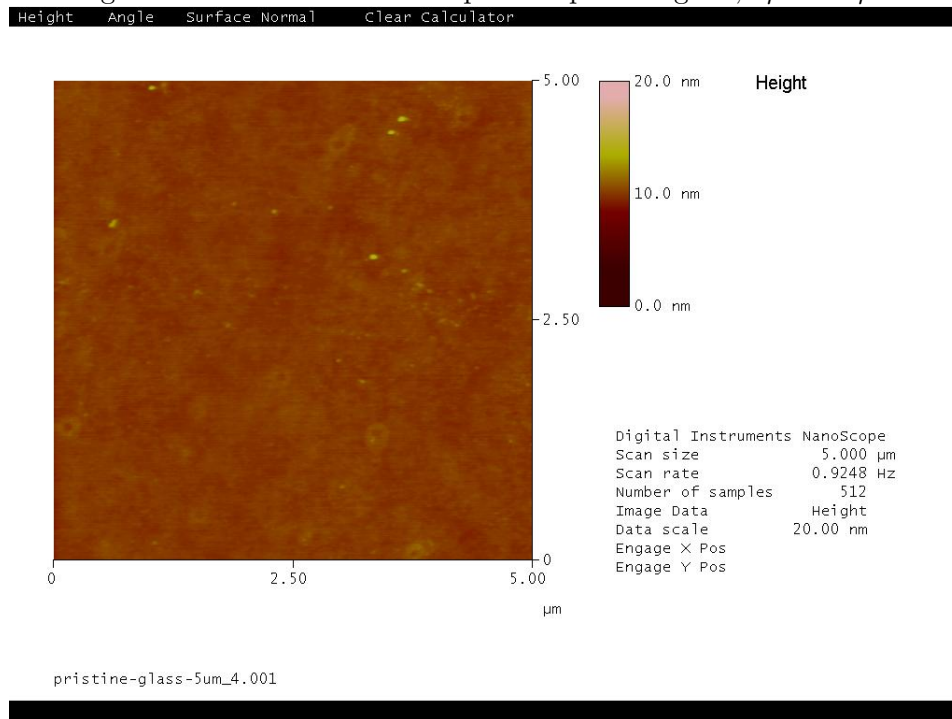

Figure 33: 3D AFM scan of third piece of pristine glass, $5\mu\text{m} \times 5\mu\text{m}$

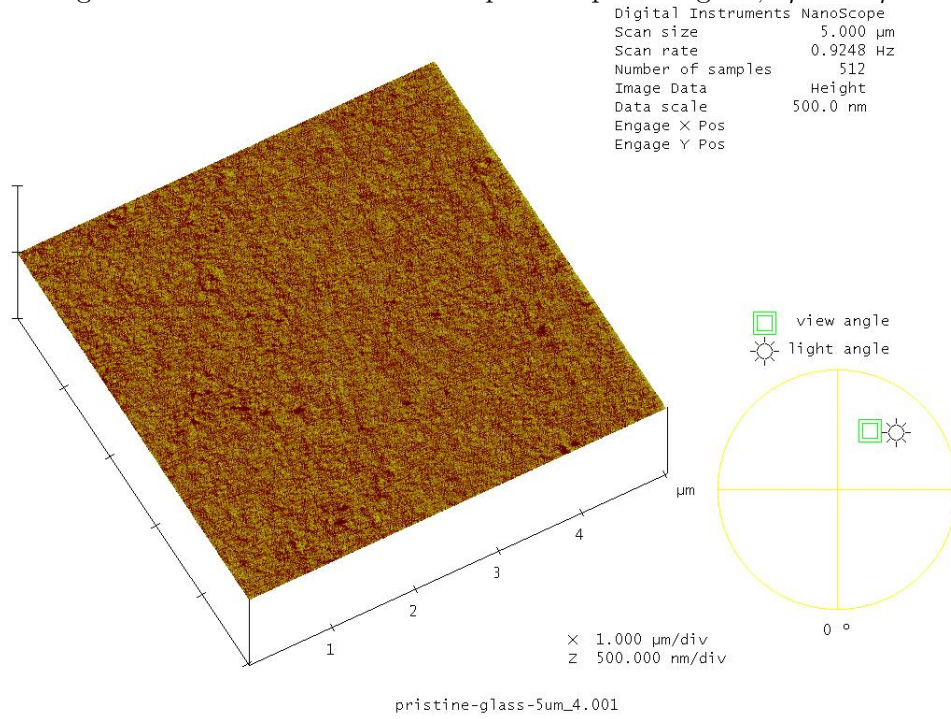

Figure 34: Roughness analysis of AFM scan of third piece of pristine glass, $5\mu\text{m} \times 5\mu\text{m}$

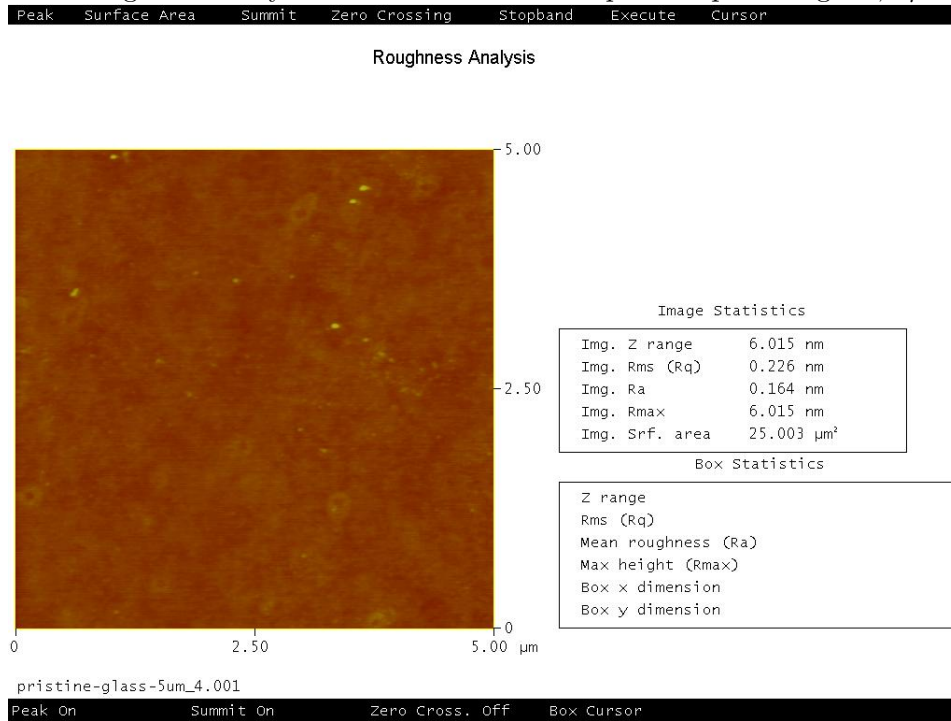

Figure 35: AFM scan of fourth piece of pristine glass, $5\mu\text{m} \times 5\mu\text{m}$

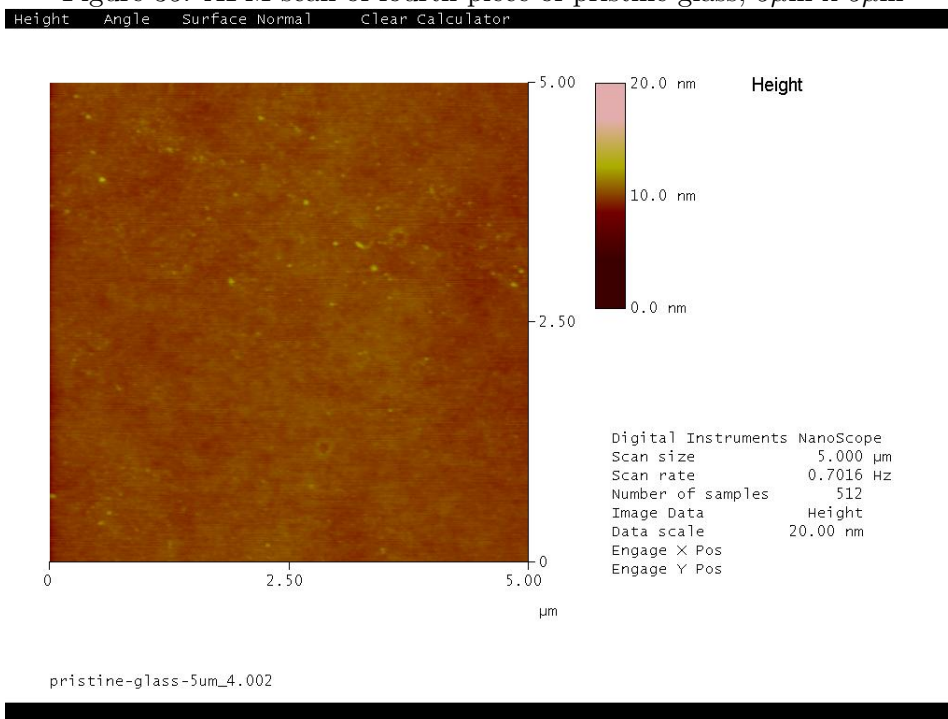

Figure 36: 3D AFM scan of fourth piece of pristine glass, $5\mu\text{m} \times 5\mu\text{m}$

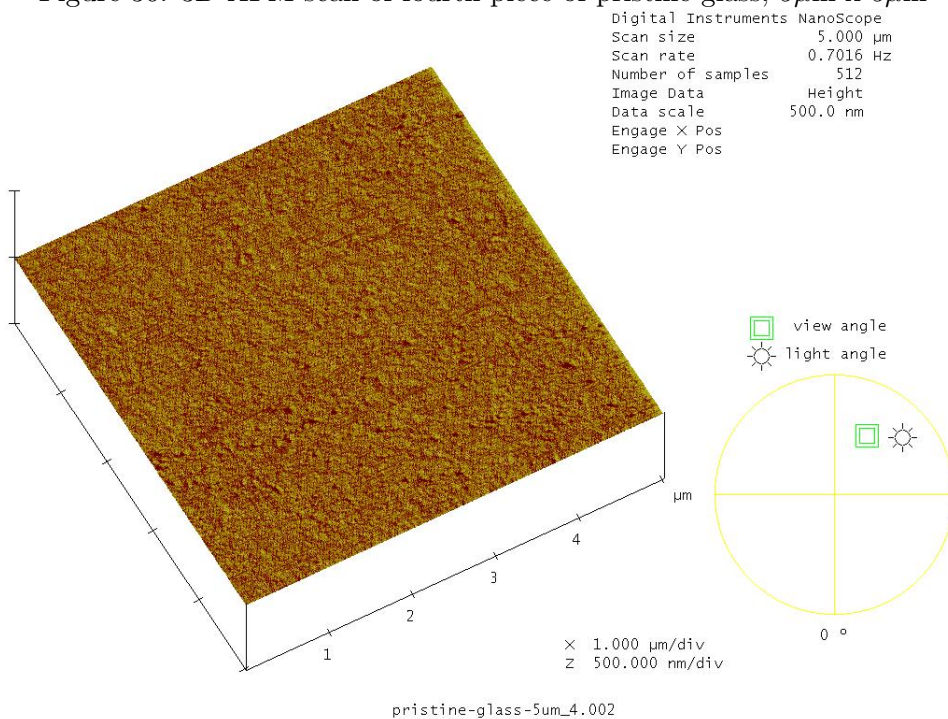

Figure 37: Roughness analysis AFM scan of fourth piece of pristine glass, $5\mu\text{m} \times 5\mu\text{m}$

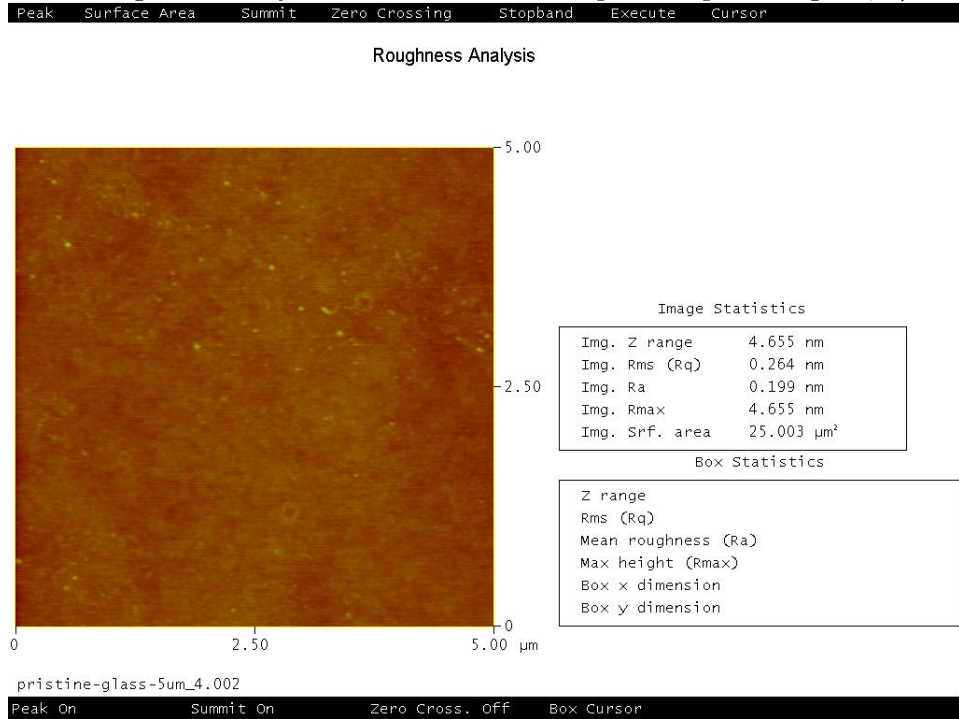

Figure 38: AFM scan of first piece hybrid cell glass, $3\mu\text{m} \times 3\mu\text{m}$

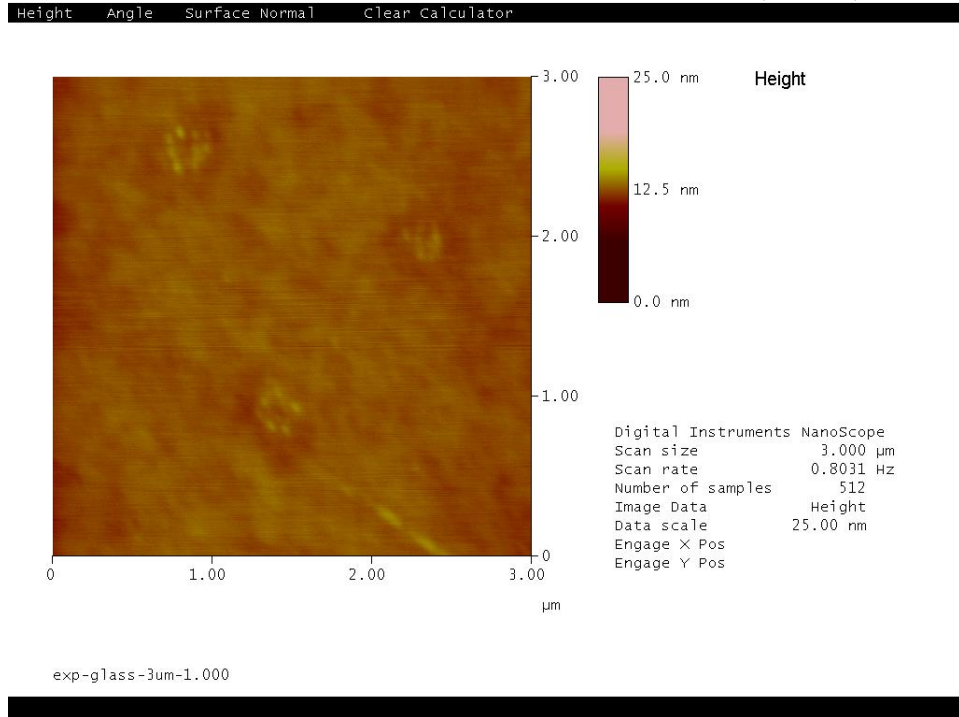

Figure 39: 3D AFM scan of the first piece hybrid cell glass, $3\mu\text{m} \times 3\mu\text{m}$

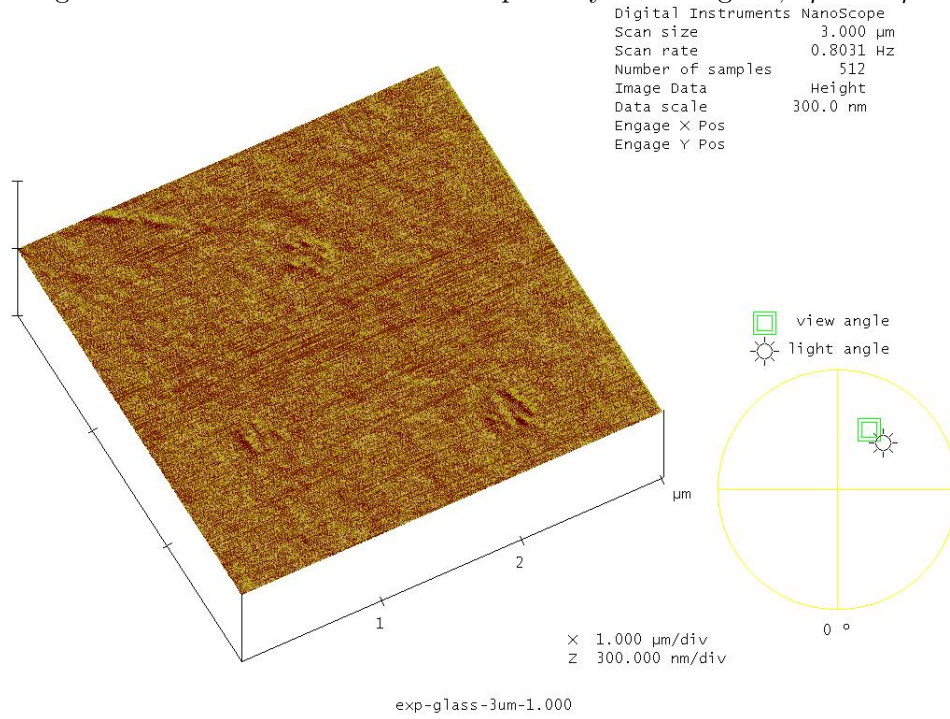

Figure 40: Roughness Analysis of AFM scan of first piece of hybrid cell glass, $3\mu\text{m} \times 3\mu\text{m}$

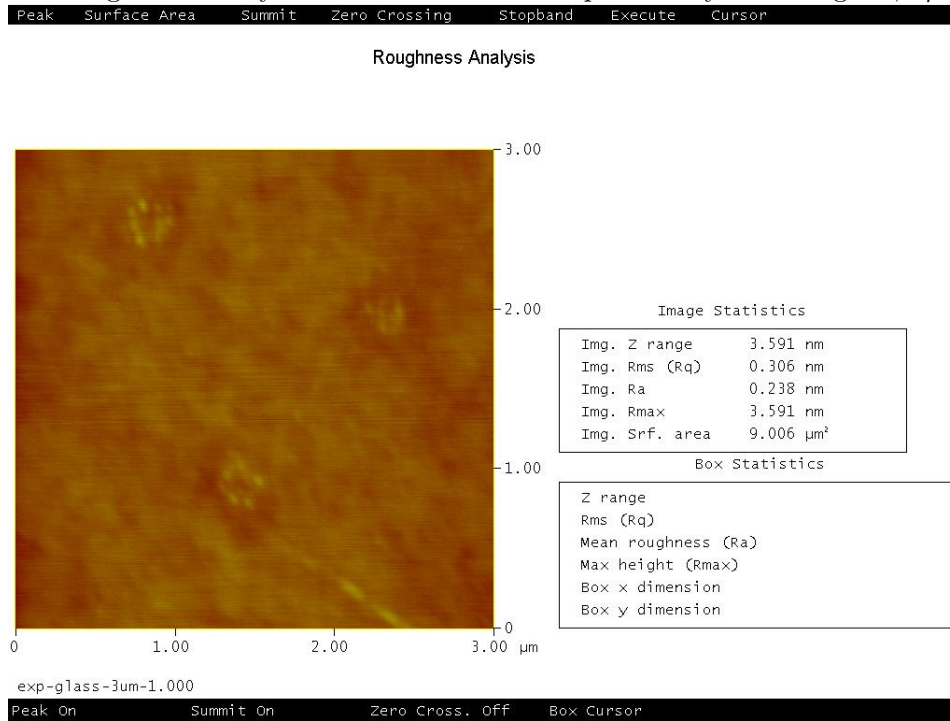

Figure 41: AFM scan of second piece hybrid cell glass, $3\mu\text{m} \times 3\mu\text{m}$

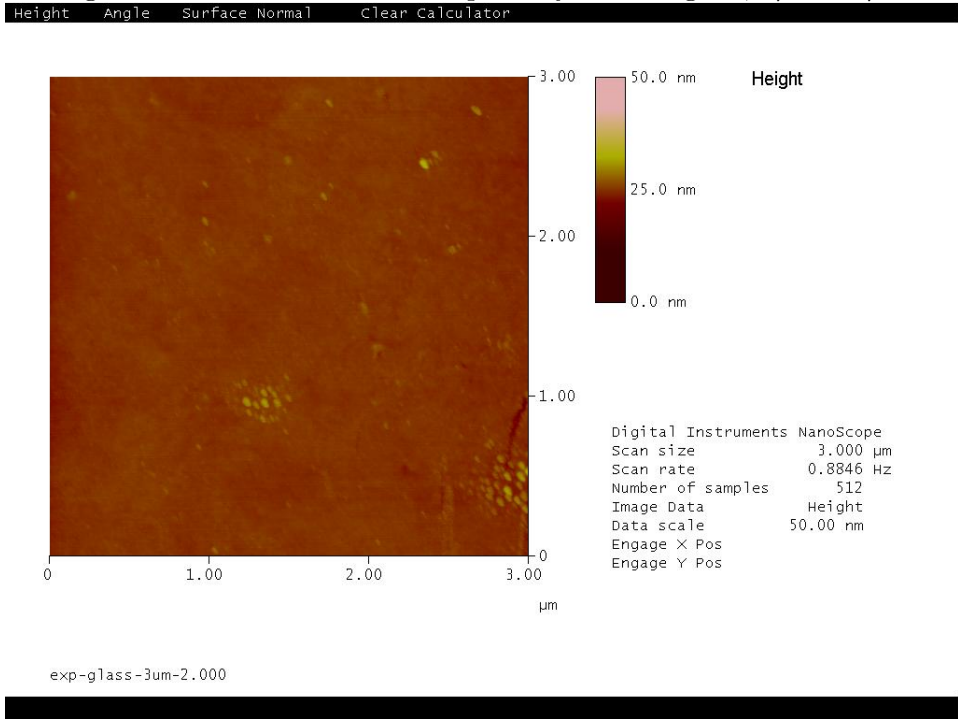

Figure 42: 3D AFM scan of second piece of hybrid cell glass, $3\mu\text{m} \times 3\mu\text{m}$

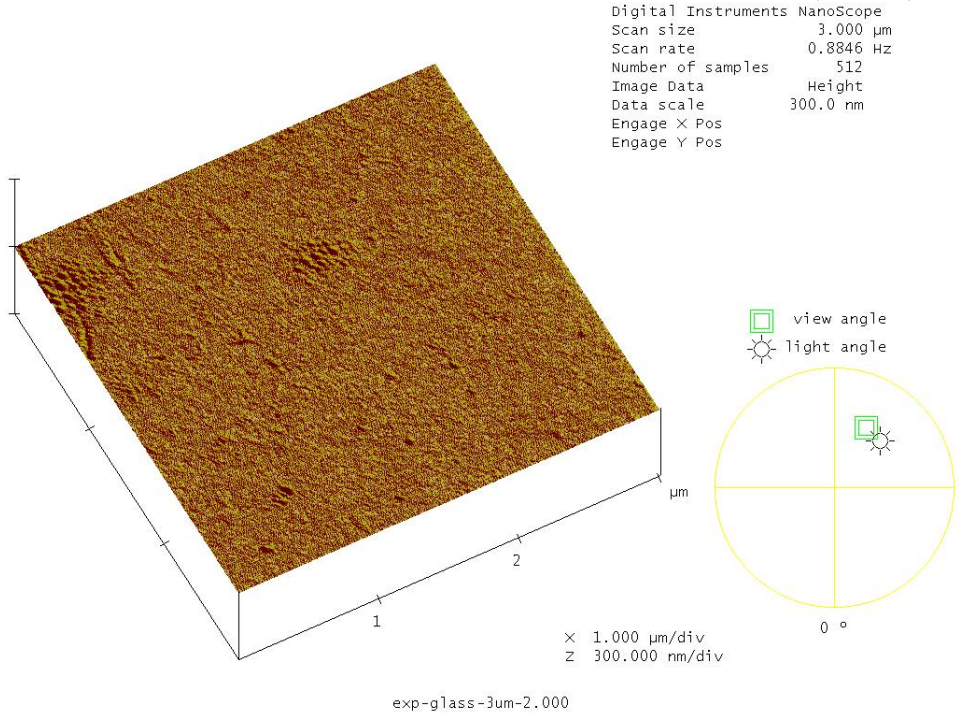

Figure 43: Roughness Analysis AFM scan of second piece of hybrid cell glass, $3\mu\text{m} \times 3\mu\text{m}$

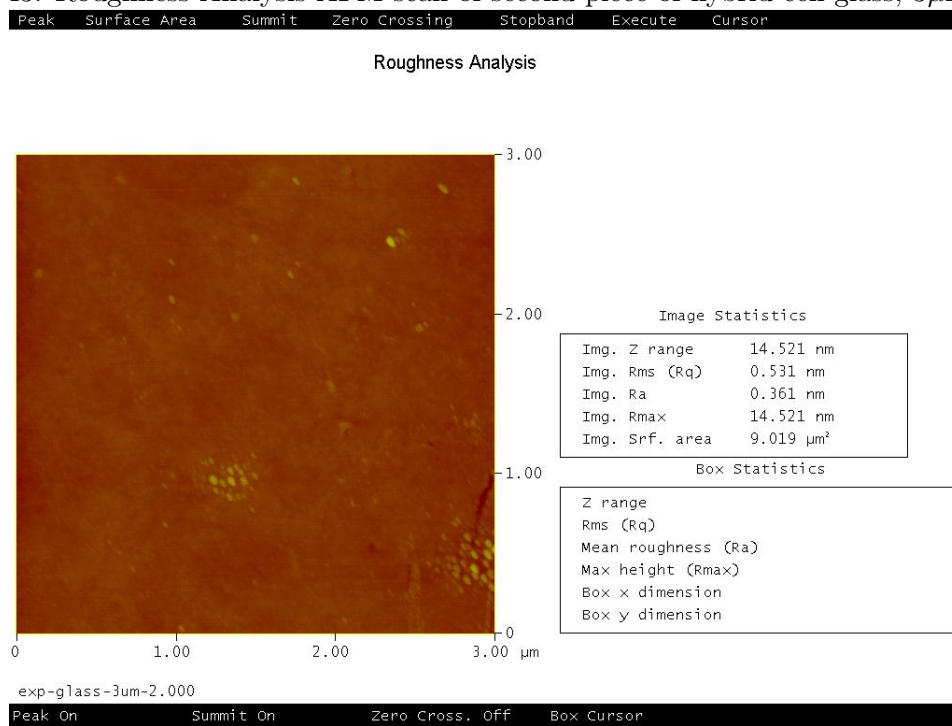

Figure 44: AFM scan of third piece of hybrid cell glass, $5\mu\text{m} \times 5\mu\text{m}$

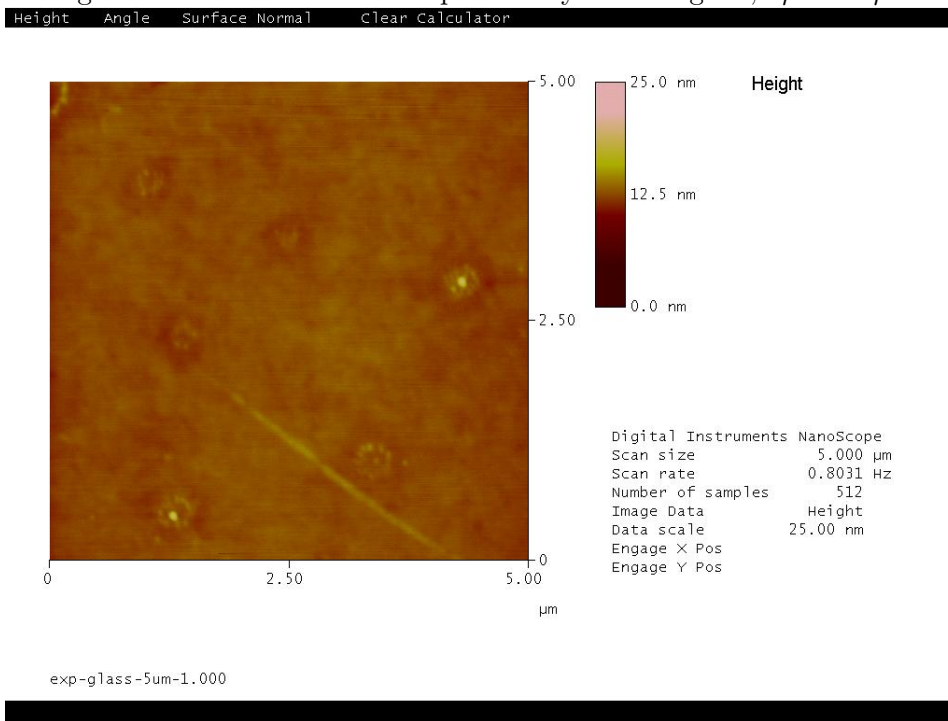

Figure 45: 3D AFM scan of third piece of hybrid cell glass, $5\mu\text{m} \times 5\mu\text{m}$

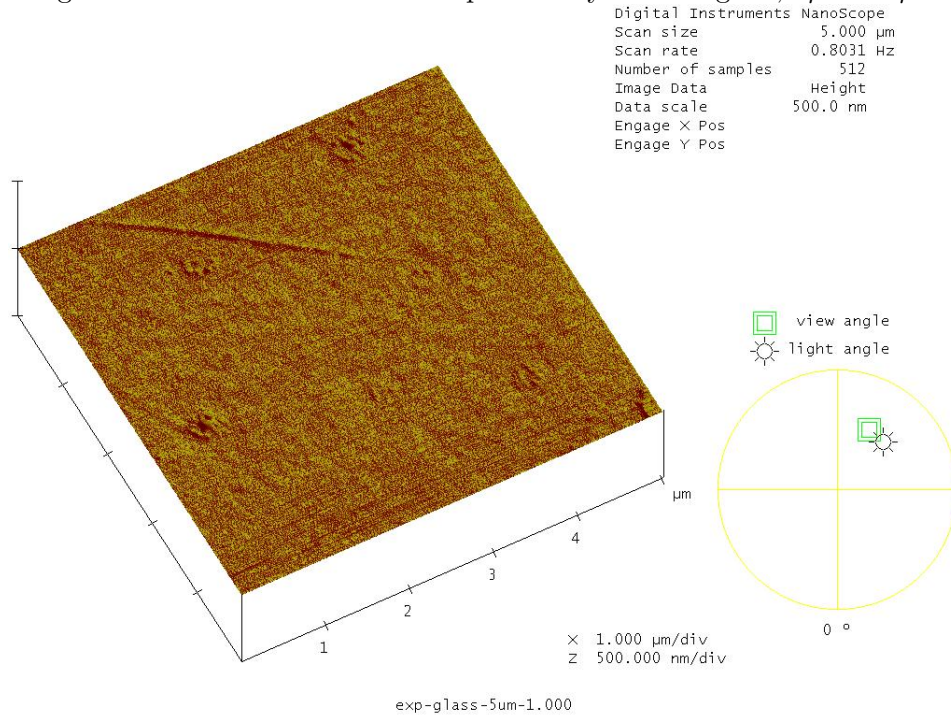

Figure 46: Roughness analysis of AFM scan of third piece of hybrid cell glass, $5\mu\text{m} \times 5\mu\text{m}$

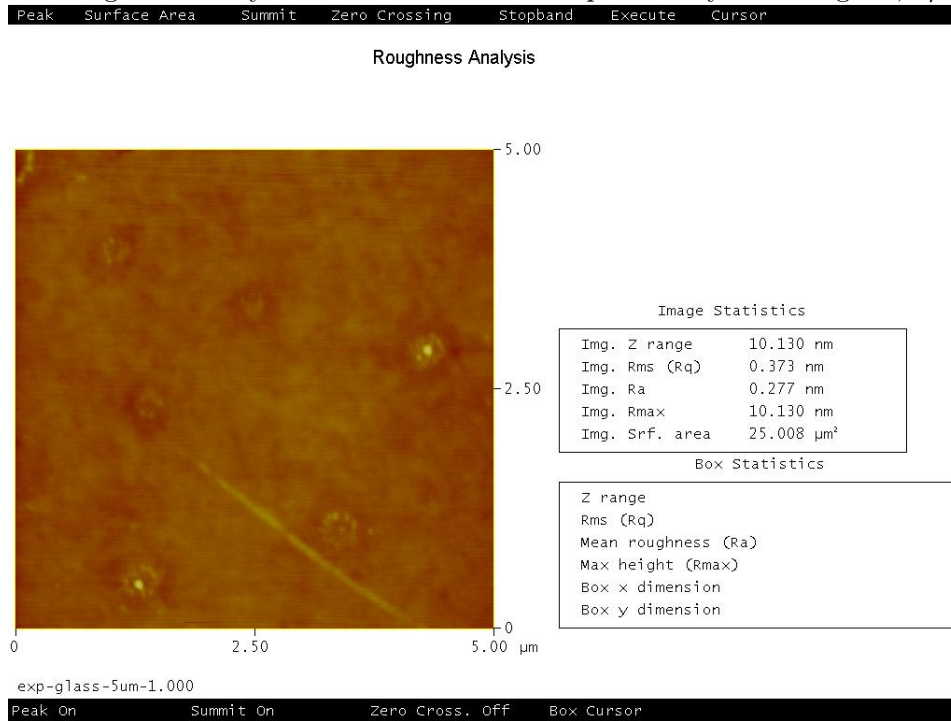

Figure 47: AFM scan of fourth piece of hybrid cell glass, $5\mu\text{m} \times 5\mu\text{m}$

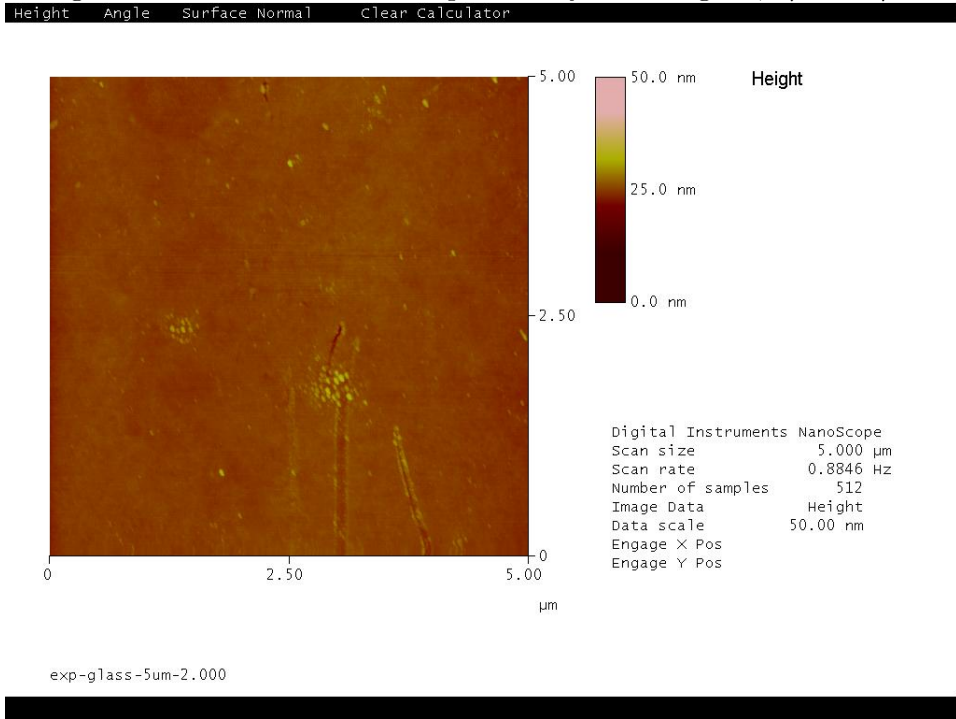

Figure 48: 3D AFM scan of fourth piece of hybrid cell glass, $5\mu\text{m} \times 5\mu\text{m}$

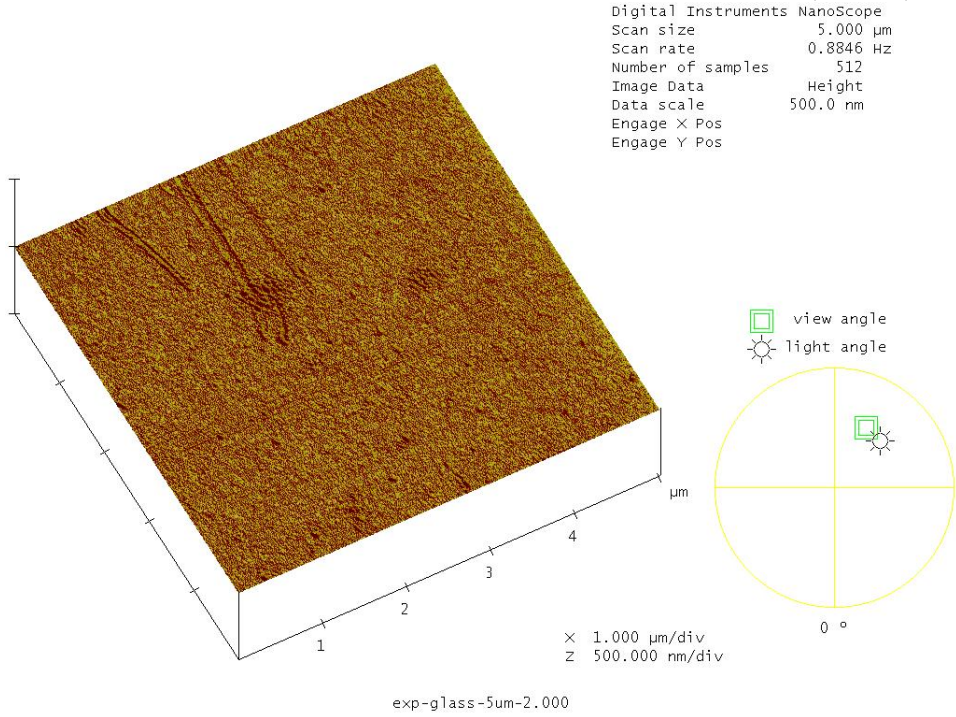
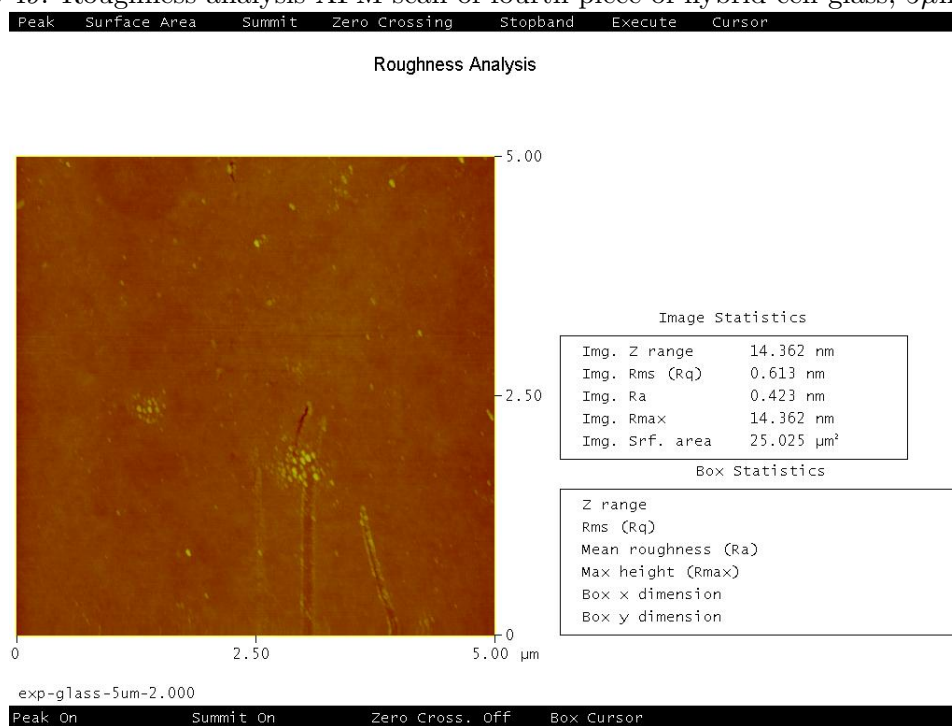

Figure 49: Roughness analysis AFM scan of fourth piece of hybrid cell glass, $5\mu\text{m} \times 5\mu\text{m}$



8 Acknowledgments

I would like to thank Professor Averett for the tremendous amount of help he gave me over the course of this year. I would also like to thank Olga and her associates at Jefferson Lab for their invaluable help with our glass surface studies.

9 References

- [1] Babcock, Earl, Ian Nelson, Steve Kadlecsek, Bastiaan Driehuys, L. W. Anderson, F. W. Hersman, and Thad G. Walker. “*Hybrid Spin Exchange Optical Pumping of ^3He .*” Physical Review Letters 91.12 (2003).
- [2] Black, Paul J., and Todd Averett. “*Characterization of Hybrid ^3He Cells Using NMR.*” Thesis. College of William & Mary, (2007).
- [3] Dolph, Peter A. “*High-Performance Nuclear-Polarized ^3He targets for Electron Scattering Based on Spin-Exchange Optical Pumping.*” Thesis. University of Virginia (2010).
- [4] Haga, Kasie J., and Todd Averett. “*Precision Characterization of Helium-3 Polarized Target Cells Using Electron Paramagnetic Resonance.*” College of William & Mary (2009).
- [5] Klutz, Kelly A., “*Studies of Polarized and Unpolarized ^3He in the Presence of Alkali Vapor.*” Thesis. College of William & Mary (2012).