

1982

Annulus formation and microstructure of hard clam (*Mercenaria mercenaria*) shells

Lowell W. Fritz

College of William and Mary - Virginia Institute of Marine Science

Follow this and additional works at: <https://scholarworks.wm.edu/etd>



Part of the [Morphology Commons](#)

Recommended Citation

Fritz, Lowell W., "Annulus formation and microstructure of hard clam (*Mercenaria mercenaria*) shells" (1982). *Dissertations, Theses, and Masters Projects*. Paper 1539617529.

<https://dx.doi.org/doi:10.25773/v5-fdfq-jx73>

This Thesis is brought to you for free and open access by the Theses, Dissertations, & Master Projects at W&M ScholarWorks. It has been accepted for inclusion in Dissertations, Theses, and Masters Projects by an authorized administrator of W&M ScholarWorks. For more information, please contact scholarworks@wm.edu.

ANNULUS FORMATION AND MICROSTRUCTURE OF HARD
CLAM (MERCENARIA MERCENARIA) SHELLS

A Thesis

Presented to

The Faculty of the School of Marine Science
The College of William and Mary in Virginia

In Partial Fulfillment

of the Requirements for the Degree of
Master of Arts

by

Lowell W. Fritz

1982

APPROVAL SHEET

This thesis is submitted in partial fulfillment of
the requirements for the degree of

Master of Arts in Marine Science

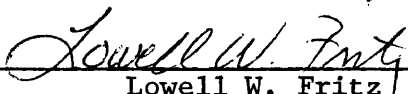

Lowell W. Fritz

Approved,



Dexter S. Haven, M.S.

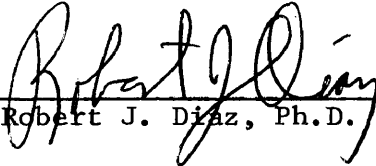

Robert J. Diaz, Ph.D.



Bruce J. Neilson, Ph.D.



Gerald H. Johnson, Ph.D.

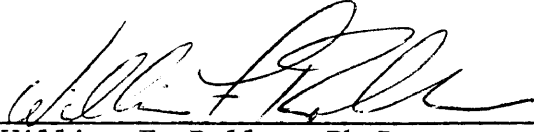

William F. Roller, Ph.D.
Computer Sciences Corp.

TABLE OF CONTENTS

| | Page |
|--|------|
| ACKNOWLEDGMENTS | iv |
| LIST OF TABLES | v |
| LIST OF FIGURES | vii |
| ABSTRACT | ix |
| GENERAL INTRODUCTION | 2 |
| INTRODUCTION TO THE SHELL STRUCTURE OF <u>MERCENARIA MERCENARIA</u> | 6 |
| MATERIALS AND METHODS | 14 |
| RESULTS | 41 |
| I. Annual Shell Growth | 41 |
| II. Daily Increments and Growth History | 84 |
| DISCUSSION | 138 |
| CONCLUSIONS | 149 |
| APPENDIX | 152 |
| BIBLIOGRAPHY | 155 |
| VITA | 161 |

ACKNOWLEDGMENTS

The support and guidance provided by Mr. Dexter S. Haven, my major professor, throughout the course of this research are sincerely acknowledged. Mr. Haven suggested the topic to me and was able, on several occasions, to help me discern forest from trees. I also wish to thank the members of my committee, Drs. Robert J. Diaz and Bruce J. Neilson of VIMS, Dr. Gerald H. Johnson of the Department of Geology, The College of William and Mary (who provided laboratory space and assistance), and Dr. William F. Roller of Computer Sciences Corp. for their support and reviews of the manuscript.

I thank the other residents of the Demonstration Building for their tolerance of odor and noise as well as their friendship. Messrs. James P. Whitcomb and Reinaldo Morales-Alamo are gratefully acknowledged for stimulating discussions, information, and critical manuscript reviews. Ms. Gloria Rowe is also to be commended for her typing and organizational skills. Finally, I would like to dedicate this work to three people whose contributions to it and my life are significant: my parents, Robert and Virginia Fritz, and Alyce D. Thomson.

LIST OF TABLES

| Table | | Page |
|-------|---|------|
| 1 | Experimental and wild clams analyzed from Virginia waters | 18 |
| 2A | Total number of known years of shell growth between 1967-1972 and dark bands in experimental clams | 44 |
| 2B | Total number of known years of shell growth between 1967-1972 defined by MDM 1, 2, and 3 years apart and dark bands in experimental clams | 45 |
| 3 | Number of experimental clams with expected number of complete dark bands after 1972 | 47 |
| 4 | Average height at age of wild clams, and calculated heights at age of wild and experimental clams from the James River | 58 |
| | Average height at age of wild clams, and calculated heights at age of wild and experimental clams from the York River | 59 |
| 6 | Shell margin growth bands of experimental and wild clams during each season | 65 |
| | Fall 'shell margin' growth bands of experimental clams, 1968-1972 | 66 |
| 8 | Growth bands in T and TI clams from 16 October 1979 to dates of collection | 71 |
| 9 | Daily increments in TI clams (summer 1980) | 87 |
| 10 | Analysis of variance (regression) of increments and days in TI clams | 88 |
| 11 | Daily increments in T and TI clams (fall 1979-summer 1980) | 91 |
| 12 | Analysis of variance (regression) of increments and days in T and TI clams | 92 |

LIST OF TABLES (continued)

| Table | | Page |
|----------|---|------|
| 13 | Analysis of variance (regression) of increments and days in T and TI clams collected prior to 4 December 1980 | 96 |
| 14 | Analysis of variance (regression) of increments and days in T and TI clams collected on or after 4 December 1980 | 97 |
| 15 | Percent agreement between increments and days between MDM in Lot XI clams, 1969-1972 | 102 |
| 16 | Percent agreement between increments and days between MDM in Lot II clams, 1968-1972 | 104 |
| 17 | Average increment width in growth bands of T and TI clams (fall 1979-summer 1981) | 120 |
| 18 | Daily increments in growth bands of T and TI clams (fall 1979-summer 1981) | 123 |
| 19 | Expressions of winter 1980-1981 in shell microstructure of T and TI clams | 134 |
| Appendix | | |
| | Spring 1981 light band and summer 1980 dark band in T and TI clams with no distinct winter growth cessation marks | 153 |

LIST OF FIGURES

| Figure | | Page |
|--------|--|------|
| 1 | Radial section of hypothetical experimental hard clam | 7 |
| 2 | SEM micrograph of prismatic layer of TI clam | 9 |
| 3 | Side and anterior views of shell exterior of hard clam | 15 |
| 4 | Chart of lower James River | 20 |
| 5 | Chart of lower York River | 22 |
| 6 | Enlargements of acetate peels of three experimental clams (ABC) | 48 |
| 7 | Annual increments in Lot XI clams, 1973-1977 | 53 |
| 8 | Annual increments in Lot II clams, 1973-1977 | 55 |
| 9 | Height at age according to Walford expressions of wild and experimental clams in James and York Rivers | 61 |
| 10 | Percent of young, mature, old, and all ages of experimental and wild clams with light or dark bands at the shell margin in each season | 67 |
| 11 | Enlargements of acetate peels of five T and TI clams (ABCDE) | 72 |
| 12 | Width of growth bands in T and TI clams (spring 1980-summer 1981) | 79 |
| 13 | Daily increments in TI clams (summer 1980) | 89 |
| 14 | Daily increments in T and TI clams (fall 1979- summer 1981) | 93 |
| 15 | Daily increments in T and TI clams, divided by collection prior to or after 4 December 1980 | 98 |
| 16 | Percent agreement between increments and days between MDM in Lot XI clams, 1969-1972 | 106 |

LIST OF FIGURES (continued)

| Figure | | Page |
|--------|--|------|
| 17 | Percent agreement between increments and days between MDM in Lot II clams, 1968-1972 | 108 |
| 18 | Average increment width in growth bands in experimental clams (Lots XI and II), 1969- 1972 | 112 |
| 19 | Daily increments in growth bands in experimental clams (Lots XI and II), 1969-1972 | 114 |
| 20 | Average increment width in growth bands of T and TI clams (fall 1979-summer 1981) | 121 |
| 21 | Daily increments in growth bands of T and TI clams (fall 1979-summer 1981) | 124 |
| 22 | Daily noon water temperatures at VIMS pier, York River, October 1979 to June 1981 | 128 |
| 23 | Enlargement of acetate peel of T clam with four growth cessations or growth rate reductions in summer 1980 | 131 |

ABSTRACT

Microstructure of radial sections of hard clam (Mercenaria mercenaria) shells from lower Chesapeake Bay was investigated in acetate peels to define an annulus and determine the time of year of its formation. Shells of experimental (those clams with monitored periods of growth) and wild stock hard clams were analyzed. Dark bands in the middle homogenous layer were formed each summer and early fall by all clams analyzed; thus, dark bands were annuli in hard clam shell microstructure. Distinct winter growth cessation marks in light bands (formed in fall through spring) were not such consistent features of annual shell increments.

Experimental hard clams formed one increment in the prismatic shell layer during each solar day in which individuals were active. Periods of inactivity were represented by growth cessation marks, which were thick organic lines in the prismatic layer. The 1:1 increment to day relationship became weaker as monitored growth periods increased in duration to include one or more winters. Also, duration of inactive periods in a year increased as hard clam age increased, thus reducing the number of daily increments formed in annual shell increments with age.

Growth rates (average daily increment widths) were slower in summer (dark bands) than in fall or spring (light bands). Decreased summer growth rates were most probably due to water temperatures greater than the optimum range for shell growth by hard clams.

Differences in seasonal growth rates by clam age groups were evident. Clams older than 8 years tended to have slower growth in fall than younger clams. Thus, dark band formation in old clams either extended longer into fall than in young clams, or old clams did not grow in fall and winter. This masked the appearance of distinct winter growth cessation marks in the shell microstructure of older (and some younger) clams. Consequently, the dark band was the only structure formed by all age groups of hard clams each year.

ANNULUS FORMATION AND MICROSTRUCTURE OF HARD
CLAM (MERCENARIA MERCENARIA) SHELLS

GENERAL INTRODUCTION

The hard clam, Mercenaria mercenaria, is an important commercial bivalve in lower Chesapeake Bay as well as along the entire east coast of the United States (Miller et al. 1975). Landings in Virginia from lower Chesapeake Bay and its tributaries (excluding the Potomac River) in the period 1972-1979 averaged over 600,000 pounds of meats and yielded over \$650,000 in ex-vessel revenue per year (NOAA 1974-1981). Virginia's contribution to the total landings of hard clams from all Middle Atlantic states (Massachusetts to Virginia) has been between 10-15% (Miller et al. 1975).

Hard clams are harvested in Virginia using both patent and hand tongs. Introduction of more modern gear into the fishery, most notably hydraulic escalator harvesters, has been recently denied by the general assembly of the Commonwealth of Virginia. However, other states have allowed their use (Miller et al. 1975). Hydraulic escalator harvesters are very efficient in capturing hard clams in 3-4 m of water from most bottom types (MacPhail 1961). Measured rates of capture range between 8 (Austin and Haven 1981) and 60 (MacPhail 1961) times greater with an escalator harvester than with conventional gear.

Sound management of a fishery using such efficient harvesting methods is critical to prevent over-exploitation of the resource. However, very little is known of the dynamics of hard clam populations in lower Chesapeake Bay (Haven et al. 1973). Knowledge of rates of

recruitment, mortality (natural and fishing), and growth in different areas of the lower bay must be integrated into a management program. To measure growth rates, an accurate and reliable age determination technique is required. Other important parameters used in studies of exploited populations which depend on age determinations include age-specific fecundity and meat yield (Tesch 1971; Ricker 1975).

Previous investigations of hard clam growth rates in lower Chesapeake Bay have involved annual morphometric measurements of marked individuals over a series of years (Haven et al. 1973; Loesch and Haven 1973). These studies yielded Walford (1946) growth equations which related size (clam length) and age in the James and York Rivers. However, accurate age determinations from size alone using these equations are not possible due to the great variation in size at age exhibited by hard clams (Haven et al. 1973; Loesch and Haven 1973). Another method of hard clam age determination utilizing major external shell rings or circuli, as suggested by Belding (1912), Kerswill (1941), and Haskin (1954), may lead to inaccurate results. Other investigators have shown that a wide variety of disturbances can interrupt bivalve growth and produce a circulus on the shell exterior which may be misidentified as an annual ring (e.g. Weymouth 1923; Pannella and MacClintock 1968; Jones et al. 1978; Thompson et al. 1980). Furthermore, as growth rate declines with age, annual rings on the shell exterior become so crowded that accurate age determinations are not possible (Mason 1957).

Barker (1964) showed that more detailed and accurate information on pelecypod growth can be obtained by examination of radial sections of a single valve. He initially reported the existence of

growth lines in the microstructure of shell sections and speculated on their periodic nature. Growth lines, bands, or patterns which are formed annually have since been identified in the shell microstructure of several molluscs, including Cerastoderma edule (Farrow 1971), Geukensia demissa (Lutz 1977; Lutz and Rhoads 1978; Lutz and Castagna 1980), and Spisula solidissima (Jones et al. 1978; Ropes and O'Brien 1979). Furthermore, annual growth bands in Mercenaria mercenaria have been investigated by Clark (1979) in populations off Georgia. The work of Lutz and his colleagues on the shell layer ultrastructure of Geukensia demissa, however, indicates that annual patterns of growth may not be the same in all populations of a species along its latitudinal range. Consequently, variation in annual shell structural units may preclude the universal application of a defined annulus to all populations along the range of a species.

In this study, annual and sub-annual growth was investigated in the shell microstructure of Mercenaria mercenaria from lower Chesapeake Bay. Shells examined were from both experimental (those with a period of known growth-history) and wild stock clams. Some of the experimental clams analyzed were from the same growth lots established by Haven et al. (1973) and Loesch and Haven (1973). The documented growth-history of these clams was longer than that of any other group of experimental bivalves used in previously published shell-growth studies. A description of seasonal and annual growth represented in the shell microstructure of Mercenaria mercenaria from lower Chesapeake Bay and how they relate to other populations along its latitudinal range will further our understanding of this valuable resource. As further

introduction to this study, a brief description of the shell structure of Mercenaria mercenaria will be presented.

INTRODUCTION TO THE SHELL STRUCTURE OF

MERCENARIA MERCENARIA

I. Main shell layers

The shell of Mercenaria mercenaria is composed of four crystalline layers which are (from the exterior inward): 1) the prismatic layer, 2) the middle homogenous layer, 3) the pallial myostracum, and 4) the inner homogenous layer (Pannella and MacClintock 1968) (Figure 1)). The prismatic layer is constructed of regular prisms of aragonite and organic matrix which are deposited sub-perpendicular to the shell exterior. Furthermore, the prismatic layer is divided into incremental growth structures. In radial section, these appear as thin organic lines also lying sub-perpendicular to the shell exterior which separate regions of high aragonite content (Figure 2). Organic, or growth line formation has been attributed to periods of internal anaerobiosis when the valves are closed and the animal is not ventilating the mantle cavity (Lutz and Rhoads 1977). Lutz and Rhoads (1977), using the work of Dugal (1939) and Crenshaw and Neff (1969), postulated that acidic end-products of glycolysis which accumulate in the extrapallial fluid dissolve calcium carbonate from the internal shell surface. An acid-insoluble organic residue of decalcified shell is left behind along the internal shell surface after dissolution of calcium carbonate. New shell added during the next period of aerobic deposition is laid directly upon this organic surface, thus forming one

Figure 1. View of radial section of hypothetical experimental hard clam (Mercenaria mercenaria) showing the four crystalline layers: outer prismatic (op), middle homogenous (mh), pallial myostracum (pm), and inner homogenous (ih). This clam was measured and re-planted during the years shown, leaving measurement disturbance marks in the shell microstructure. (After Pannella and MacClintock (1968) and Rhoads and Pannella (1970)).

MEASUREMENT DISTURBANCE MARKS
(MDM)

1967 1968 1969 1970 1972

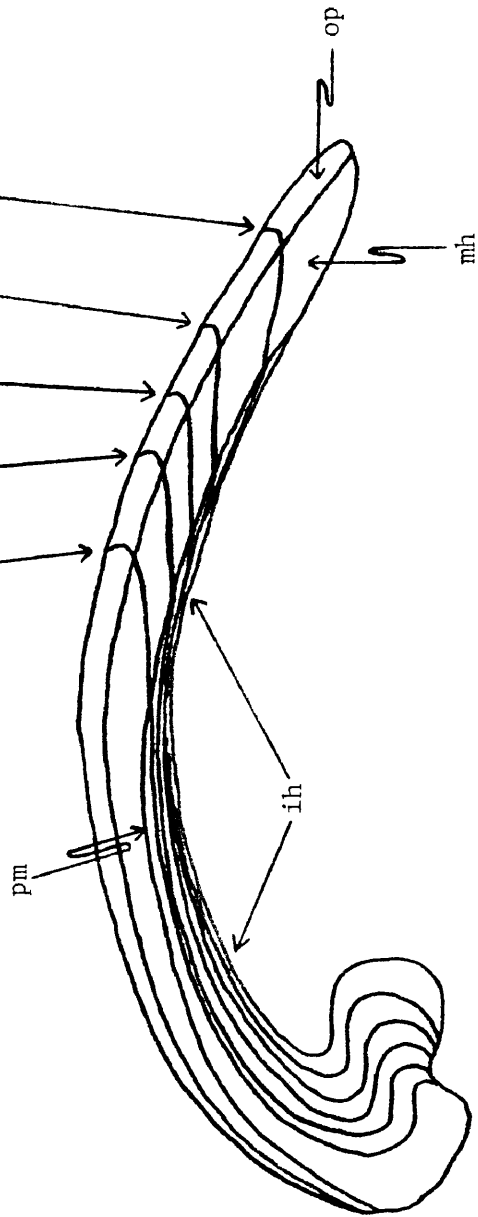
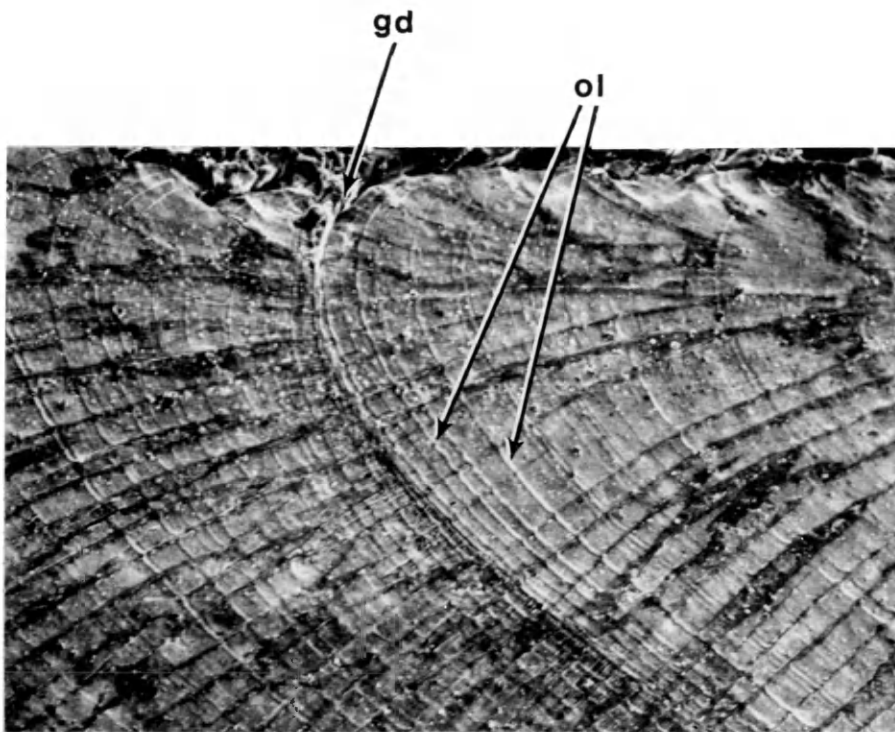

Figure 2. Scanning electron micrograph of the prismatic layer of a TI series clam (T101). Curved ridges from the upper left to the lower right are organic growth lines (ol) which separate regions higher in calcium carbonate. One daily increment consists of two organic lines and the calcium carbonate between them. Thick organic line (gd) represents the growth disturbance of 29-30 May 1980. Growth is to the left and the shell exterior surface is at the top.

SEM preparation: Air-dried specimen was coated with gold-palladium in vacuum evaporator. The specimen was observed and photographed with an AMR model 1000 SEM at 10 kV accelerating voltage and a 200 μm final aperture.



100 μ

organic, or growth line. After many such aerobic and anaerobic periods, a series of alternating calcium carbonate-rich and organic-rich layers (or lines) remains in shell microstructure. This is termed a series of growth increments, with one increment consisting of a single calcium carbonate-rich layer and the two organic lines which bracket it. Growth increments in series, then, represent periods of active shell growth (calcium carbonate-rich layers) separated by periods of inactivity when calcium carbonate is dissolved (organic lines). Consequently, activity patterns of individual animals are represented by growth increments in the prismatic layer (Thompson 1975).

Knowledge of the periodicity of formation of growth lines and increments in the prismatic layer has yielded information on cyclical geophysical phenomena (i.e., the tides, solar day) to which shell growth and activity in the species are attuned (Pannella and MacClintock 1968; Pannella 1975; Thompson 1975; Pannella 1976). Prismatic increments in M. mercenaria are usually referred to as daily increments since one is formed for each solar day of activity and growth (Pannella and MacClintock 1968; Thompson 1975). Similarly, thick organic lines separating increments are evidence of long periods of inactivity and are termed growth disturbance or cessation marks (Kennish and Olsson 1975; Gordon and Carriker 1978 (Figure 2)).

Determinations of growth rate from shell microstructure are made by measuring the width of a series of successive daily increments. Richardson et al. (1980) measured growth rates of Cerastoderma edule by a similar procedure using circatidal increments in the peripheral shell layer. In M. mercenaria, daily increments are often curved or reflected back toward the umbo near the shell exterior

surface (Figure 2). Consequently, to accurately determine growth rates, measurements of daily increments must be made along the surface of maximum growth (SMG) which is located within the prismatic layer (Pannella and MacClintock 1968). This surface is defined as the curvilinear plane along which the animal deposits shell most rapidly (Pannella and MacClintock 1968). With respect to prismatic daily increments viewed in radial section, the SMG is located where the width of each increment (distance between organic lines) is greatest. This is also where organic lines are perpendicular to the shell exterior surface.

Of the remaining three shell layers, the middle and inner homogenous layers and the pallial myostracum, only the middle homogenous layer is of interest in analyzing shell growth in microstructure. The two homogenous layers are both composed of sheet-like nacreous tablets (Pannella and MacClintock 1968). In the inner homogenous layer, aragonitic sheets are deposited parallel to the inner shell surface, while in the middle homogenous layer, they are arranged at an angle intermediate between those in the inner layer and organic lines in the prismatic layer (see Figure 1). Individual growth increments in the prismatic layer are seldom distinguishable in the middle and never in the inner homogenous layers. However, the middle homogenous layer is composed of light and dark bands which are associated respectively with wide and narrow daily increments in the prismatic layer (Clark 1979 (see Figure 6A-C)). Light and dark bands in the middle homogenous layer discussed in this study are equivalent to 'opaque' and 'transparent' zones, respectively, described by Clark (1979) (see Results section I).

II. Definition of the annulus

An annulus is any visible structure in the shell or its cross-section which is formed only once each year. Annuli could occur in some or all shell layers and be macroscopic features such as the bands in Mya arenaria (MacDonald and Thomas 1980) or the intrusions of one layer into another in Spisula sachalinensis (Kato and Hamai 1975). On the other hand, annuli could also be microscopic features such as the changes in shell layer ultrastructure in Geukensia demissa (Lutz 1977; Lutz and Rhoads 1978; Lutz and Castagna 1980). The important considerations of an annulus, however, are that it be formed only once each year and be readily recognizable once defined. Furthermore, an annual shell increment is defined as the amount of shell, as measured along the SMG, from the end of one annulus to the end of the next toward the shell margin.

MATERIALS AND METHODS

I. Sources of Mercenaria mercenaria for study

A. Experimental clams with long known growth history (Lots I, II, XI, and XIV)

Clams from long-term growth studies initiated in 1967 by the Department of Applied Biology (VIMS) were used in the present study because their growth history had been documented for as long as 13 years (Haven et al. 1973; Loesch and Haven 1973). Clams used in their studies were originally obtained in one of two ways: 1) they were purchased from local commercial dealers who bought clams harvested from lower Chesapeake Bay, or 2) they were collected by departmental personnel. Groups of clams (lots) were then placed at marked locations in the James and York Rivers and the bayside of the Eastern Shore. Clams collected by departmental personnel were obtained from the same area as the designated lot location. Each clam in a lot was numbered (using an indelible ink pen) and measured, and the group placed directly in the bottom at the desired location by a SCUBA-equipped diver. Morphometric measurements included length (greatest distance along the anterior-posterior axis) and width (greatest distance through the valves along the axis perpendicular to both length and height) as illustrated in Figure 3. Measurements were made to the nearest 0.1 mm with Vernier calipers. Total air-dried live weight was obtained with a Sartorius

Figure 3. Side (A) and anterior (B) views of the shell exterior of the hard clam showing the axes of length, height, and width. Rings on shell surface are termed circuli. (After Haven et al. (1973)).

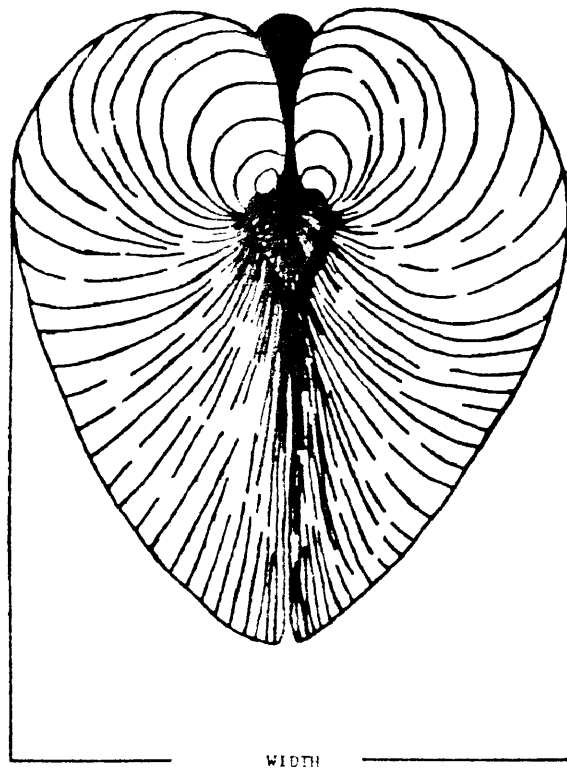
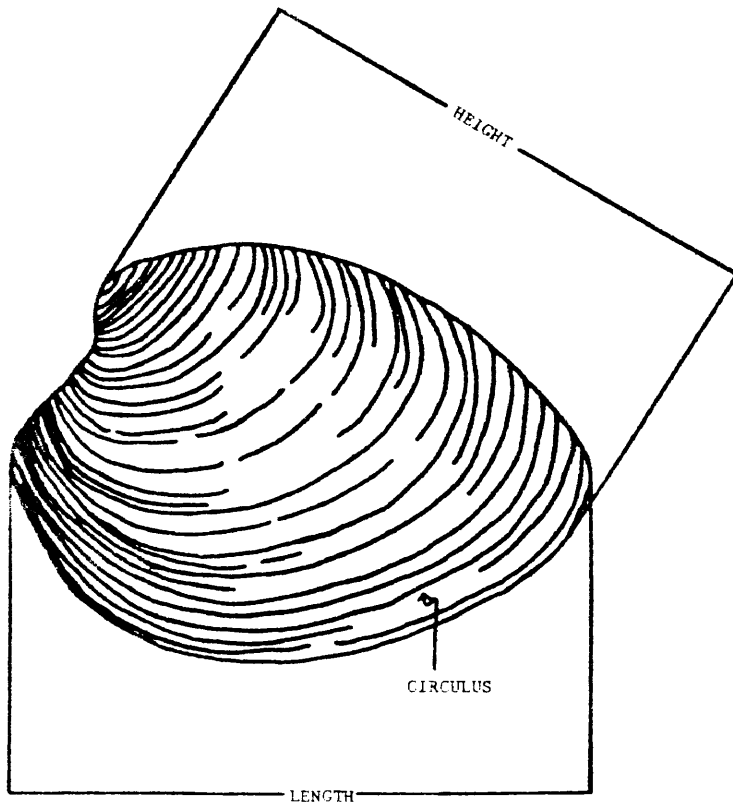

balance to the nearest 0.1 g. Weight measurements were not used in the present study.

As many clams from each lot as could be found by a diver were retrieved each year in fall from 1967 to 1972. Since the clams were placed directly in the bottom and not held in trays, individuals were often not collected for 1 or 2 years in succession. Clams from each lot were brought to VIMS where each was measured and weighed. Each lot was returned to its respective location usually within one week from the collection date. While at the laboratory, each lot was kept separately in a flow-through seawater table receiving ambient York River water. Clams were often added to an existing lot at the time of measurement each fall.

Clams in all lots remained in the bottom continuously from the fall of 1972 to the date of final collection between 1976 and 1980. At this time, as many clams as possible were collected from each lot location, measured, and shucked. The shells were carefully stored in boxes according to lot number until they were used in the present study.

Eighty-nine single valves of clams from experimental lots I, II, XI, and XIV were chosen for microstructural analysis (Table 1). These lots were chosen on the basis of: 1) geographic location (to include both the James and York Rivers), 2) complete long-term growth data available, 3) depth distribution (from barely subtidal to subtidal), and 4) final collection date (to include summer and winter dates). Locations of lots in the James River (Lot XI) and York River (Lots I, II, XIV) are shown in Figures 4 and 5. Undamaged individuals spanning the size range of each lot were chosen for analysis if their

Table 1. Experimental and Wild Clams Analyzed from Virginia Waters.

A. Experimental

| Lot No. | Location | Date of Lot Establish- ment | Depth (m) below MLW | Bottom Type | No. of Clams | Date of Final Collection |
|-----------|-------------|-----------------------------------|------------------------|-------------|-----------------|--------------------------------|
| I | York River | 9/ 8/67 | 0.5 | Muddy-sand | 16 | 12/22/76 |
| | | | | | 1 | 6/22/80 |
| | | | | | 1 | 7/18/80 |
| II | York River | 9/10-13/67 | 1.5 | Sandy-mud | 15 | 8/25/76 |
| | | | | | 10 | 1/ 3/78 |
| | | | | | 8 | 2/ 9/78 |
| XI | James River | 1/24/69 | 1.8 | Muddy-sand | 26 | 7/12/79 |
| XIV | York River | 9/26/69 | 1.5 | Sandy-mud | 6 | 8/25/76 |
| | | | | | 6 | 1/ 3/78 |
| T-Series | York River | 10/16/79 | 0.5 | Muddy-sand | 68 | Monthly to 6/27/81 |
| TI-Series | York River | 5/29/80 | 0.5 | Muddy-sand | 15 | Summer 1980 and 6/27/81 |
| Total | | | | | 172 | |

Table 1. (continued)

B. Wild

| Lot No. | Location | Depth (m) below MLW | Bottom Type | No. of Clams | Date of Collection |
|-------------|---------------------------|------------------------|----------------------------------|-----------------|-----------------------|
| XV | James River | 2.5 | Muddy-sand | 5 | 4/20/78 |
| LC | Lynnhaven Bay | 0.5 | Muddy-sand | 2 | 7/31/78 |
| Y | York River | 0.5 | Muddy-sand | 7 | 2/2-3/80 |
| VW | Eastern Shore, Seaside | 0.5 | Silty-mud under gravel bed | 3 | 3/80 |
| DM | York River | 1.0 | Sandy-mud | 3 | 7/12/80 |
| M(22) | James River | 5.5 | Fine sand, mud | 2 | 8/ 5/80 |
| M(3) | James River | 3.5 | Sand, gravel, shell | 1 | 8/ 5/80 |
| HR | James River | 15.0 | Sandy-mud | | 9/11/80 |
| Total | | | | 24 | |
| Grand total | | | | 196 | |

Figure 4. Chart of the lower James River (north shore) showing locations of experimental lots (E) and sampling sites of wild stock clams (WS).

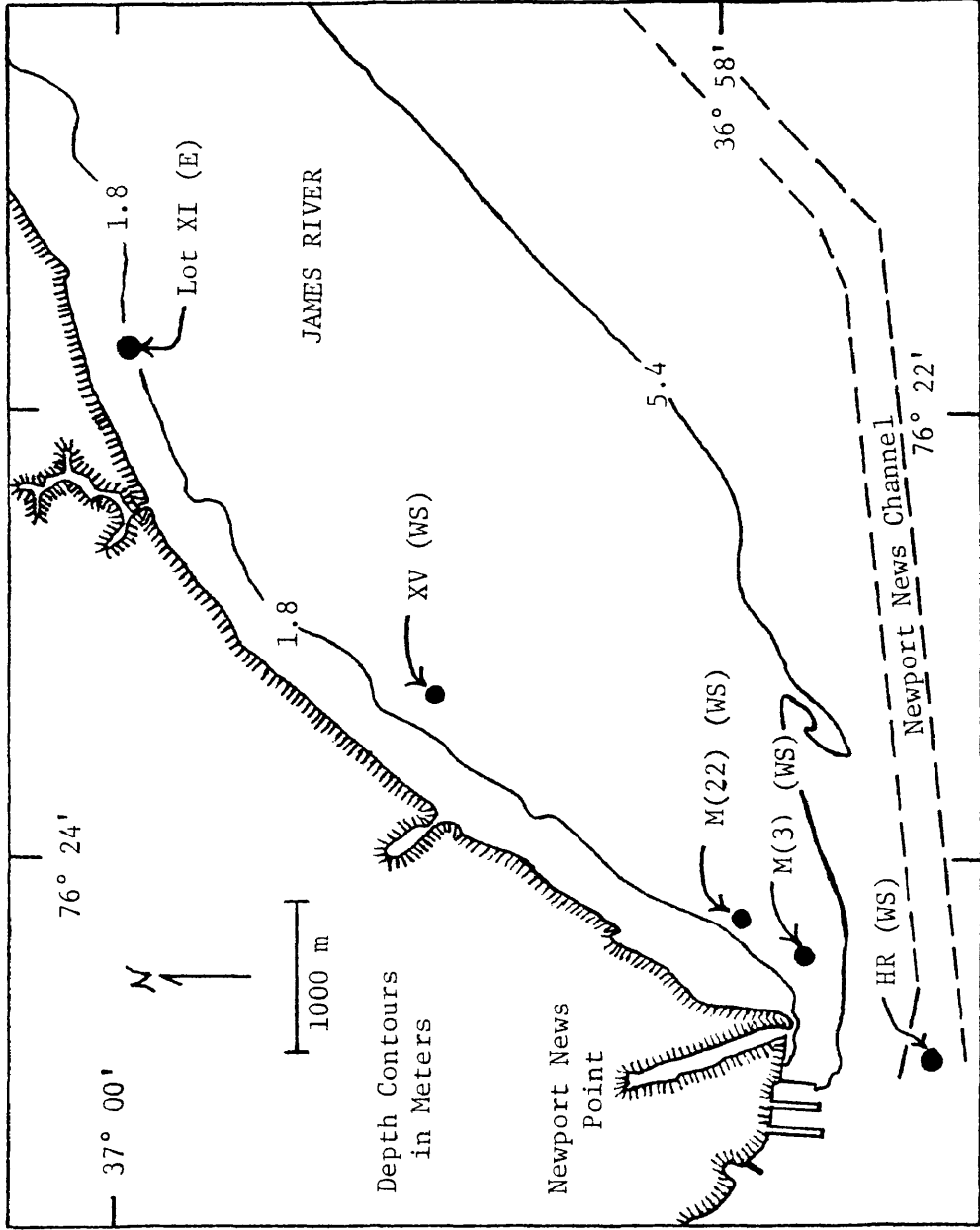
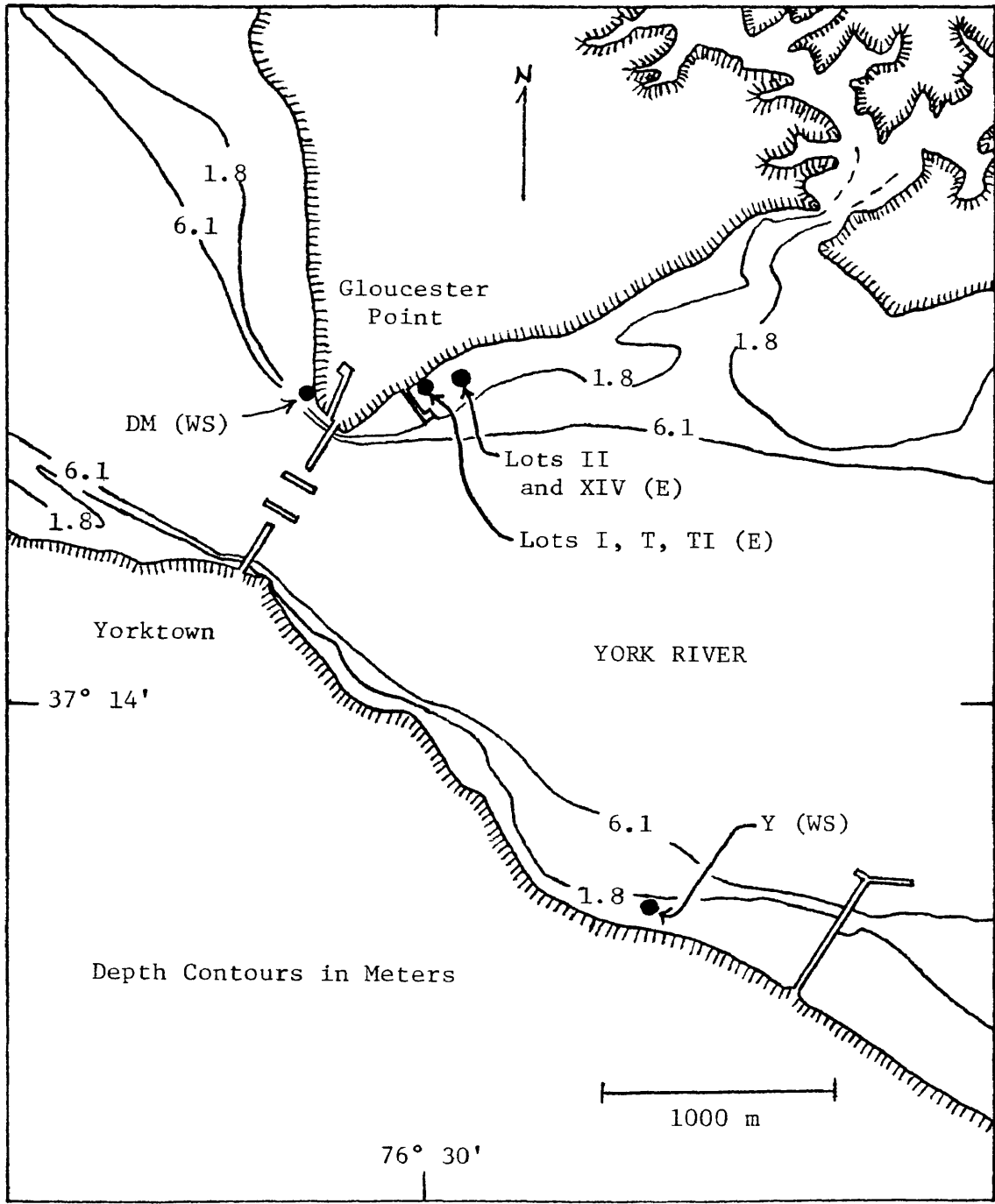

Figure 5. Chart of the lower York River showing locations of experimental lots (E) and sampling sites of wild stock clams (WS).



growth increment throughout the study period (1967 to date of final collection) exceeded 0.5 mm.

Height measurements of clams in the experimental lots were not made between 1967 and 1972. Height measurements of individual clams for each year were estimated by identifying the circulus or growth ring corresponding to the shell margin each year from the recorded length measurement (Figure 3). The shell height was measured from the identified circulus to the umbo. A size-time relationship along the height axis of each clam was critical to this study for it was along this axis that valves were cut for microstructural examination. This relationship was then used as a baseline for identification of annuli and analyses of growth.

B. Experimental clams set out during this study
(T and TI series)

The T and TI series was composed of a single year-class of clams set out at Gloucester Point in the York River (Table 1; Figure 5) on 16 October 1979. Collections from these groups were used to analyze in detail seasonal and daily growth of hard clams. Age 2+ clams were obtained from the VIMS hard clam hatchery at Wachapreague on 2 October 1979. The group of clams from which T and TI clams were collected had been reared from spawning stock and transplanted to a grow-out site at the end of their first summer of growth in the fall of 1977. Shell lengths averaged approximately 10 mm at this time (J. Kraeuter, pers. comm.). The grow-out site was at a depth of approximately 0.5 m MLW in a creek near Wachapreague with a silty-mud bottom covered by a bed of gravel. Salinities were between 28 and 30 ppt on 2 October 1979

(J. Kraeuter, pers. comm.), when T and TI clams were collected. Clams were randomly obtained from the grow-out site with hand rakes and transported on ice to Gloucester Point. Each clam was individually numbered and measured as described for other experimental lots. However, height measurements were obtained instead of width.

Attempts were made to mark the growing edge of T and TI clam shells with tetracycline hydrochloride as suggested by Dey and Bolton (1978). Tetracycline is incorporated into shell during its deposition due to its affinity for calcium. Shell added while in the presence of tetracycline will appear bright orange-yellow under ultra-violet light, thus marking the time period in shell microstructure. Once such a benchmark is created, growth bands, marks, and increments in shell added subsequently can be related to it.

T and TI clams were exposed to tetracycline hydrochloride-seawater solutions of 75 or 100 mg/l every other day (6 h/day) for 2 weeks starting 3 October 1979. Two liters of a Chlorella spp. suspension were also added during each marking attempt. Analysis of the microstructure of all T and TI clams collected during fall and winter of 1979 and 1980 revealed that little or no growth had occurred. This lack of activity immediately after transplantation precluded incorporation of tetracycline into shell and was probably due to the 10 ppt difference in salinity between the grow-out site and the York River (16-18 ppt). However, the growth disruption in microstructure clearly marked the shell edge at the time of transplantation (see Figures 11A-E). This appeared as a thick organic line extending through all shell layers.

T and TI clams were removed from the sea-table (where tetracycline marking was attempted) and planted individually in subtidal

bottoms of the York River at Gloucester Point on 16 and 17 October 1979. Collections of four clams each were made at approximately monthly intervals from then until 27 June 1981 (total n=68; Table 1). Clams were measured and shucked at each collection date and the shells stored until sectioned and examined. Since T and TI clams added little shell during the fall and winter of 1979-1980, the exact date of growth resumption in spring 1980 was unknown.

The TI series was composed of T series clams in which a growth cessation was induced in the spring of 1980. This growth break was used as a baseline for determining the periodicity of formation of prismatic shell growth increments. This growth cessation mark was induced in the TI clams as follows: On 29 May 1980, 16 T clams were collected from the T series location, measured, renumbered, and placed in a moist incubator at 4°C for 24 h to disrupt shell growth. A similar growth disruption procedure conducted by Richardson et al. (1979) had no deleterious effects on further shell growth by Cerastoderma edule after three days of incubation at the same temperature. On 30 May 1980, the TI clams were replanted with the rest of the T series, but in a segregated area (Figure 5). Three clams were collected on four occasions in the summer of 1980 and once in the summer of 1981 (total n=15; Table 1). Shells were measured, shucked, and stored for later examination.

C. Wild stock clams collected during this study

A total of 24 wild stock clams from the James and York Rivers, Lynnhaven Bay, and the seaside of the Eastern Shore were collected

during winter, spring, and summer of 1978 and 1980. Shell height and length and live, air-dried weight were measured on each clam.

Clams collected from Lynnhaven Bay and the seaside of the Eastern Shore (n=5) were originally supplied by the VIMS hard clam hatchery at Wachapreague and transplanted to those sites at the end of their first summer of growth. They were undisturbed until collected in 1978 and 1980. Descriptions of collection sites in all areas appear in Table 1. Collection sites in the James and York Rivers also appear in Figures 4 and 5.

II. Preparation of hard clams for microstructural analysis

Acetate peels of each clam listed in Table 1 were prepared according to the methods of Stewart and Taylor (1965), Pannella and MacClintock (1968), and Rhoads and Pannella (1970). One valve of each clam was carefully cleaned and air-dried for several days. It was then imbedded in Clear-Cast Liquid Casting Plastic (American Handicrafts, Fort Worth, Texas) to prevent the shell from chipping and cracking during the cut. The procedure follows: A small amount of liquid plastic with catalyst was poured into a mold and allowed to harden for about one-half hour. After this interval, the plastic was viscous enough to allow the valve (shell exterior down) to sink, but not all the way to the bottom of the mold. The valve was also pre-coated with plastic on the shell exterior to prevent bubble formation along this surface. To insure that the ventral edge of the valve was parallel to the bottom of the mold, it was held in place by bent paper clips until the plastic hardened sufficiently to hold it in place. Liquid plastic

was then added to completely cover the valve and allowed to harden for at least 2-3 days before cutting. Care was taken in the mixing of catalyst and resin to insure slow hardening which prevented cracking of the plastic. A minimum amount of catalyst (1/2 to 1 drop per ounce of resin) was used in preparation.

Plastic-imbedded shells were cut from ventral edge to the umbo along the height axis (Figure 3) using a Felker geological saw. One of the two sectional surfaces was chosen for further preparation on the basis of the quality of the cut. It was ground flat using medium and fine grit diamond laps or 300 grit carborundum powder on glass plates. Each sectional surface was then ground and polished further using 600 grit carborundum powder on glass plates and optical quality grits (labelled 'intermediate' and 'fine') on a cloth-covered rotating disc polisher. Final polishing was done either by hand or with the disc polisher using cerium oxide. Distilled water was used in the final rinse.

The polished cross-sectional surface was etched in either 1% or 5% HCl for 20-60 seconds. The acidic solution dissolved carbonates but not organic matrix leaving increment boundaries as ridges along the sectional shell surface (see Figure 2). Optimum etching times varied among clams depending on organic content and 'chalkiness' of the valve. Test etchings were conducted on representative clams to determine optimum etching times. The more dilute acid (1%) produced acetate peels of greater clarity, although optimum etching times tended to be about 10-15 seconds longer. After etching, the surface was rinsed in distilled water three times to remove any acid. It was allowed to

air-dry for 24 h or placed in an oven at 50°C for 1/2 hour and allowed to cool and dry for approximately six hours.

An acetate peel is an impression in acetate of the shell sectional surface after etching which is suitable for light microscopy. The shell cross-sectional surface was flooded with acetone and an acetate strip (0.003 inches thick) placed on it. Care was taken to insure that a pool of acetone formed at the ventral end of the plastic block by placing it, sectional surface up, in a box of sand. The block was tilted so that the umbo-end was slightly higher than the ventral end. One edge of the acetate strip was placed first in the acetone pool at the ventral edge and then lowered onto the inclined surface of the block pushing the acetone pool ahead of it. This insured contact between all parts of the shell surface with acetone and acetate. The amount of acetone required, however, varied among specimens and was determined by experience. Acetate sheets were air-dried on the sectioned surface for at least 1 h, after which they were removed, trimmed, labelled and stored between glass microscope slides or sheets of clear plastic (0.5 mm thick).

All examinations of annual, seasonal, and daily hard clam growth in acetate peel replicas of shell microstructure were conducted at 100X on an American Optical microscope. Widths of growth bands were measured using an ocular reticle with an estimated accuracy of ± 1 reticle unit (10.8 μm at 100X).

III. Definition of shell structural terms unique to this study

A. Measurement disturbance marks (MDM)

A characteristic growth disturbance mark was created in the shell microstructure of each experimental clam in lots I, II, XI, and XIV each time it was retrieved, measured, and replanted in the fall of each year between 1967 and 1972. This measurement disturbance mark, or MDM, appeared as a thick organic line in the prismatic layer which often extended into the middle homogenous layer (see Figure 6A-C). An MDM definitively located the portion of each annual shell increment which was deposited in fall.

B. Shell margin growth bands

Growth bands in this study refer to light and dark bands in the middle homogenous layer. To identify the time of year of light and dark band formation, hard clam growth bands at or near the ventral shell margin were examined. Consequently, a shell margin growth band is a light or dark band in the middle homogenous layer which was being formed on the date of collection. This band, however, must have been formed for at least a short period prior to collection as well in order for it to be observed. For instance, in Figure 6B, a dark band constitutes the shell margin growth band, while in Figure 6C, it is a light band.

C. Fall 'shell margin' growth bands

The series of MDM's in the shell microstructure of each retrieved experimental clam in lots I, II, XI, and XIV located the former shell margins in the fall of each year they were measured between 1967 and 1972. Growth bands formed prior to the collection date each fall were observed in the middle homogenous layer immediately dorsal (toward the umbo) to each MDM. These bands were termed fall 'shell margin' growth bands.

IV. Methods of annulus identification and determination of time of formation

A. Annulus identification in experimental and wild clams

1. Experimental lots I, II, XI, and XIV

Shell growth in clams from experimental lots I, II, XI, and XIV was separated into two distinct periods based on the treatments to which clams were subjected. During the first period (between 1967 and 1972), clams in each lot were retrieved from the lot location in the fall of each year and morphometric measurements taken before they were returned to the bottom. During the second period (from 1972 until the final collection date), clams remained in the bottom continuously for 4 to 8 years. The number of years of undisturbed growth during each of these two periods should be represented in each clam by a similar number of annual growth marks or annuli. On this basis, the known years of shell growth represented by the two periods were used to prove the formation of an annulus by hard clams in the four lots.

a. Shell growth from 1967 to 1972

Annulus formation in shell deposited from 1967 to 1972 was investigated using the known years of shell growth (which define known shell increments) located in microstructure by the series of MDM's. Figure 1 is a drawing of the radial section of a hypothetical clam from one of the four lots showing five MDM's caused by collection and replanting each fall in 1967, 1968, 1969, 1970, and 1972. It was not collected or measured in 1971. The four MDM's formed in 1967 through 1970 define three known annual shell increments, those formed between 1967-1968, 1968-1969, and 1969-1970. Furthermore, there are three known years of shell growth in this clam described by these four measurements made annually. There is also one biannual shell increment (which should have two annuli) defined by measurements taken in 1970 and 1972. In this period of shell growth, there are two known years which are defined by measurements made two years apart. In summary, there are five known years of shell growth in this individual, three defined by collections made every year and two by collections made every other year. The total number of known years of shell growth for all clams in each lot were summed individually for each of three ways in which they were defined; known years of shell growth were defined by measurements taken 1, 2, or 3 years apart. The number of annuli observed in the shell increment defined by MDM's made 1, 2, or 3 years apart should equal the number of known years of shell growth. Furthermore, grand totals of the number of MDM's, known years, and annuli for each and all lots were obtained.

b. Shell growth from 1972 to the final collection date

Annulus formation in shell deposited between 1972 and the date of final collection was investigated by comparisons of the numbers of known years of undisturbed growth and complete annuli in shell microstructure. Complete annuli were defined as those which were not being formed at the shell edge, but were separated from it by a different growth band in the middle homogenous layer. For instance, in Figure 6B, there are 3 complete annuli between the MDM of 1972 and the shell margin (labelled 1973, 1974, and 1975). In Figure 6C, five complete annuli are shown (labelled 1973, 1974, 1975, 1976, and 1977).

Widths along the SMG from the end of each complete annulus to the end of the next were measured. The year to which each annual increment corresponded was determined on the basis of its position in the order of all annuli from the MDM of 1972 to the shell margin, which corresponded to the final collection date (see Figure 6A-C). The annual shell increments corresponding to each year between 1973 and 1977 in each clam from lots II and XI were plotted together to show the synchrony among clams in their growth over these five years. Furthermore, widths of each annual increment were divided by the total 1973-1977 shell growth in each clam to obtain yearly percentages of total growth. The resulting percentages were independent of differences in the absolute size of each annual increment due to the age of individual clams.

2. Wild clams from the James and York Rivers

The shell microstructure of 9 wild clams from the James River and 10 from the York River was investigated for annuli similar to those observed in experimental clams. However, no periods of shell growth were known in wild clam microstructure. Consequently, Walford (1946) growth equations based on shell heights at the end of annuli similar to those observed in experimental clams were calculated. These two equations, one each for James and York wild clams, were compared to Walford equations based on annual measurements of experimental clams in the two rivers derived by Haven et al. (1973). This, in itself, does not prove the annual periodicity of formation of the designated annulus. However, if growth equations derived from height measurements at each assumed annulus (age) are similar to equations derived from annual morphometric measurements of clams in the same river, then the assumption of annual periodicity is supported.

The age of the nineteen wild clams was determined by counting the number of assumed annuli, and shell heights at each were measured. Average shell heights at each age were calculated and used to derive two Walford growth equations. These have the general form,

$$H_{t+1} = H_{\infty}(1-k) + kH_t$$

where H_t and H_{t+1} are shell heights (in mm) at the ventral end of two adjacent annuli, H_{∞} is the asymptotic height, and k is a growth constant. The characteristics of k are such that the greater its value, the slower H_{∞} is approached in time (Walford 1946).

Walford equations of Haven et al. (1973) were based on shell length measurements of experimental clams in the James and York Rivers obtained between 1968 and 1970. Experimental lots of clams used by Haven et al. (1973) were the same as those used in the present study and described previously. Their equations, based on length, were converted to equations based on height using an expression relating the two shell axes. This expression was generated by least-squares regression of 103 simultaneous height and length measurements of wild and experimental hard clams in the James and York Rivers obtained during the present study. The length to height conversion was applied to calculated average lengths at each age from the two equations of Haven et al. (1973). Resulting calculated average heights at age were then used to derive another pair of Walford growth expressions and these were compared with two similar equations based on shell height at assumed annuli of wild clams.

B. Time of year of annulus formation

The time of year of annulus formation was determined through analyses of shell margin and fall 'shell margin' growth bands of experimental and wild clams. Results from experimental clams (lots I, II, XI, and XIV) integrated 13 years of monitored shell growth and revealed the season of annulus formation. Details of annulus formation were followed through collections of T and TI clams made over a 15 month period.

1. Shell margin and fall 'shell margin' growth bands

Shell margin growth bands in the middle homogenous layer of experimental and wild clams were catalogued according to the seasons in which individual clams were collected. Percentages were calculated for clams forming light or dark bands at the shell margin in each season. Most clams, however, were collected in either winter or summer (100/108) and few in spring or fall (8/108; Table 1). Results were also catalogued by absolute age (in years) of experimental or wild clams at final collection. Clams were grouped by age according to three growth stages defined by Kennish (1980): 1) Young - under 3 years old, 2) Mature - 3 to 8 years, and 3) Old - over 8 years old. The rationale for these groups of ages is not relevant here.

The type of growth band at each fall 'shell margin' in experimental clams (lots I, II, XI, and XIV) were catalogued in the same manner as those at the shell margin. These were included with observations at the actual shell margin, yielding a more complete annual series of growth band formation.

2. Shell margin growth bands and band width measurements in monthly collections of T and TI clams

The color of shell margin growth bands in each T and TI clam collected from 5 April 1980 to 27 June 1981 was catalogued by collection date. Furthermore, width of each band formed from the growth disturbance mark caused by transplantation to the shell margin was measured along the SMG. In this manner, increase in width of shell

margin growth bands with time and their replacement at the margin by different bands were monitored for 15 months.

V. Methods of daily increment analysis

Daily increments in the prismatic layer were analyzed in experimental clams for two purposes: 1) to determine the periodicity of their formation by hard clams in lower Chesapeake Bay, and 2) to describe the relationship between daily increments and seasonal growth bands in the middle homogenous layer. Clams from experimental lots II and XI as well as the T and TI series were used in daily increment analyses. Counts were made in those shell regions which were bracketed by growth disturbance marks of known formation time (such as two MDM's) or one growth disturbance mark and the shell margin. All increment counts from individual clams were averages of three separate trials. Guidelines suggested by Crabtree et al. (1979/1980) were used in this study to distinguish and count daily increments. These are:

- 1) Count only those lines which appear to be major.
- 2) Major lines are determined by distinctness and relative length, not by width. Both wide and narrow lines may be considered major.
- 3) The lines must follow the curvature of other lines.
- 4) When it is difficult to determine whether a line should be counted, trace the line down to the inner portion of the shell and compare its distinctness there.
- 5) Be consistent.

A. Periodicity of increment formation

Three sets of increment counts from experimental clams were used to determine the periodicity of their formation and describe their relationship with monitored periods of growth. The first set was the number of increments from the growth disturbance of 29-30 May 1980 to the shell margin in twelve TI series clams collected on four dates in the summer of 1980. These counts were regressed on the number of days from 30 May 1980 to the dates of collection. The regression coefficient (slope) of the resulting expression estimated the periodicity of increment formation with respect to the solar day. This value should be 1, if one increment was formed each day.

The second set of counts was comprised of the total number of increments from the growth disturbance of 16 October 1979 to the shell margin in all T and TI clams collected on or after 5 April 1980 (excluding one collected on that date; n=58). Counts from clams collected prior to 5 April 1980 were excluded because little or no shell was added by the group in the fall and winter of 1979 and 1980. Daily increment counts of clams collected on or after 5 April 1980 were regressed on the number of days from 16 October 1979 to the dates of collection and the expected value of the regression coefficient was also 1. Counts from this group were also subdivided according to collection date to observe effects of the winter of 1980-1981 on daily increment counts. All counts from collections between 5 April 1980 and 1 November 1980 (spring to fall 1980) were regressed on days separately from counts from collections between 4 December 1980 and 27 June 1981 (winter 1980 to summer 1981).

All regressions performed on counts in sets 1 and 2 above were least squares linear regressions using analysis of variance (ANOVA) as described by Sokal and Rohlf (1969). Comparisons of regression coefficients were done in one of two ways: 1) with a t-test (t_s), if the comparison was between a calculated regression coefficient and its expected value, or 2) with an F-test (F_s), if the comparison was between two calculated regression coefficients (Sokal and Rohlf 1969). Standard errors and confidence limits of regression coefficients were calculated according to Sokal and Rohlf (1969).

The third set of counts was composed of the number of daily increments between each pair of MDM's formed one year apart in clams from experimental lots II and XI. Each count was divided by the number of solar days between measurements, which yielded the percent agreement (Richardson et al. 1979) between increments and days in defined periods of shell growth approximately one year in duration. Data were pooled both by absolute clam age and the year of growth to determine effects of both factors on the number of increments formed by clams in defined periods. Data from years prior to 1972 were pooled within each lot to compare with 1972 data and thus, observe the effects of tropical storm Agnes.

B. Daily increments and their relationship to bands in the middle homogenous layer

Daily increments were also counted between all MDM's formed 1, 2, or 3 years apart in experimental clams from lots II and XI. All daily increment counts from experimental clams (those in lots XI and II

as well as the T and TI series) were subdivided further according to the growth band in the middle homogenous layer with which they were associated. In this manner, the number of days of growth in each band (or season) could be determined. The width of each growth band along the SMG was measured in order to calculate average daily increment widths or growth rates. However, locating the single daily increment in the prismatic layer which corresponded with the beginning or end of a dark band was often a subjective decision if daily increments were wide and the dark band diffuse and pale-colored. Daily increment counts in each band for each year from 1969 to 1972 in clams from lots XI and II were analyzed separately to observe the effects of tropical storm Agnes on the number and average width of daily increments formed in 1972.

RESULTS

I. Annual shell growth by Mercenaria mercenaria in lower Chesapeake Bay

Acetate peels of etched radial shell sections are replicas of incremental growth patterns in microstructure suitable for light microscopy. In this study, dark and light bands in the middle homogenous layer of polished shell sections corresponded exactly with regions of low and high light transmittance, respectively, on acetate peels. Factors which could affect light transmittance through portions of acetate peels of etched shell sections are:

- 1) Distance between organic increment boundaries (seasonal changes in growth rate),
- 2) Regularity of crystalline deposition (lamellar or crossed-lamellar structures), and
- 3) Amount of carbonaceous material etched from the polished shell surface (which could affect the depth to which carbonate between increment boundaries was removed).

Differences in light transmittance of portions of a peel could result from any one of the three factors alone. However, variations in the magnitude of etching among shell regions most probably reflect microstructural differences described by factors 1) and 2). For

convenience, regions of low and high light transmittance through acetate peels are referred to as dark and light bands, respectively, since they corresponded exactly with dark and light bands on polished radial sections. Dark and light bands on both acetate peels and polished shell sections appear to be the same as 'translucent' and 'opaque zones' in the middle homogenous layer of thin shell sections described by Clark (1979).

A. The annulus

Dark bands in the middle homogenous layer were formed only once each year in experimental and wild clams analyzed from the James and York Rivers. This will be shown by the three sets of results which follow:

- 1) Nearly exact correspondence between numbers of known years of shell growth and dark bands observed in two periods of monitored growth by experimental clams in lots I, II, XI, and XIV (1967 to 1972 and 1972 to the date of final collection),
- 2) Synchrony among experimental clams in lots XI and II in widths of annual increments formed between 1973 to 1977, and
- 3) Similarity among two pairs of Walford growth equations, one pair derived by Haven et al. (1973) from annual shell measurements of experimental clams in the James and York Rivers, and the other pair derived from shell measurements at the ventral end of each dark band in wild clams from the two rivers.

1. Numbers of known years of shell growth and dark bands in clams from experimental lots I, II, XI, and XIV

One dark band was observed in the middle homogenous layer for each known year of shell growth in both treatment periods: 1) from 1967 to 1972, and 2) post-1972. In the 1967-1972 period, the total number of known years of shell growth and dark bands observed in all clams were identical for each and all of the four lots (Table 2A). The total number of dark bands observed in known annual, biannual, and triannual shell increments was also identical to the total number of known years of shell growth for all clams in lots I, II, and XIV (Table 2B). One clam from lot XI did not form a dark band in an annual shell increment, but formed three in the following biannual shell increment. Despite this apparent discrepancy, the number of years represented by the total shell increment determined by counting dark bands (3) was identical to the number of known years of shell growth (3).

A single known annual shell increment is shown in Figure 6A. This annual increment was defined by two MDM's formed in October 1970 and October 1971. There is a light band in the middle homogenous layer toward the shell margin (to the right) of the MDM of 19 October 1970. Following the light band, there is a relatively broad and diffuse, but distinctly darker band which ends prior to the MDM of 18 October 1971. This dark band is the annulus formed in 1971. This clam was not retrieved and measured in 1972. However, a similar pattern is repeated in the next annual increment. The annual increment formed in 1972 is much narrower than the one formed in 1971, due primarily to the effects of tropical storm Agnes, which will be discussed later.

Table 2A. Total numbers of known years of shell growth between 1967 and 1972 and dark bands in the middle homogenous layer observed in the known shell increments in clams from the four experimental lots.

| Lot No. | No. of Clams Analyzed | Total No. of Known Years for all clams ¹ | Total No. of Dark bands |
|---------|-----------------------|---|-------------------------|
| I | 18 | 35 | 35 |
| II | 33 | 43 | 43 |
| XI | 26 | 86 | 86 |
| XIV | 12 | 13 | 13 |
| TOTALS | 89 | 177 | 177 |

¹ Many of the clams from each lot were added to it after the lot had been established. Because of this, the number of known years of shell growth for all clams in each lot is always less than the number of clams analyzed multiplied by the maximum number of known years of shell growth in each clam from 1967 to 1972 (5 years).

Table 2B. Total numbers of known years of shell growth between 1967 and 1972 defined by measurement disturbance marks (MDM) 1, 2, and 3 years apart and the numbers of dark bands in the middle homogenous layer observed in the known shell increments.

| Lot No. | Total Number of Known Years ¹ and Dark Bands in Shell Increments Defined By Measurements: | | | | | | | | | | | |
|---------|--|------------|---------------|------------|---------------|------------|-------------|------------|--|--|--|--|
| | 1 Year Apart | | 2 Years Apart | | 3 Years Apart | | TOTALS | | | | | |
| | Known Years | Dark Bands | Known Years | Dark Bands | Known Years | Dark Bands | Known Years | Dark Bands | | | | |
| I | 31 | 31 | 4 | 4 | - | - | 35 | 35 | | | | |
| II | 36 | 36 | 4 | 4 | 3 | 3 | 43 | 43 | | | | |
| XI | 71 | 70 | 12 | 13 | 3 | 3 | 86 | 86 | | | | |
| XIV | 6 | 6 | 4 | 4 | 3 | 3 | 13 | 13 | | | | |
| TOTALS | 144 | 143 | 24 | 25 | 9 | 9 | 177 | 177 | | | | |

¹ See Footnote 1 in Table 2A.

Experimental clams in the four lots formed one dark band each year in the middle homogenous layer between 1967 and 1972, despite the fact that each was retrieved for measurement almost every year. Experimental clams in the post-1972 period were undisturbed for between 3 and 7 complete years. Analyses of annual shell increments deposited after 1972 provided an internal control on the effects of annual retrieval and replanting on band formation between 1967 and 1972. Results from this period of shell growth also confirm that dark bands are formed once each year.

The number of complete dark bands in shell increments formed between 1972 and dates of final collection exactly equaled the number of years of undisturbed growth in 84 of 89 (94%) experimental clams analyzed from the four lots (Table 3). Bands formed by two clams during this period are shown in Figures 6B and 6C. The clam pictured in Figure 6B was collected on 25 August 1976. There are three complete dark bands in the shell increment formed after 1972 representing growth in 1973, 1974, and 1975. There is also one incomplete dark band at the shell margin. (It should be noted here that incomplete dark bands were observed most often in experimental clams collected in summer.) The clam pictured in Figure 6C was collected on 3 January 1978 and has five complete dark bands formed between 1973 and 1977.

Five of eighty-nine clams analyzed each formed one fewer dark band than there were years of undisturbed growth after 1972 (Table 3). In each case, it appeared that one of the annual increments was very narrow and that dark bands from two successive years had merged. This would lead to inaccurate age estimates, but only in 6% of the clams analyzed.

Table 3. Number of experimental clams (lots I, II, XI, and XIV) with the expected number of complete dark bands in the middle homogenous layer in known years of growth between 1972 and the date of final collection.

| Lot No. | Final Collection Date | Years Included | Expected No. of Complete Dark Bands | No. of Clams Analyzed | No. of Clams With Expected No. of Dark Bands |
|---------|-----------------------|----------------|-------------------------------------|-----------------------|--|
| II | 25Aug 1976 | 1973-1975 | 3 | 15 | 15 |
| XIV | 25Aug 1976 | 1973-1975 | 3 | 6 | 5 |
| I | 22Dec 1976 | 1973-1976 | 4 | 16 | 16 |
| II | 3Jan 1978 | 1973-1977 | 5 | 10 | 8 |
| XIV | 3Jan 1978 | 1973-1977 | 5 | 6 | 6 |
| II | 9Feb 1978 | 1973-1977 | 5 | 8 | 8 |
| XI | 12Jul 1979 | 1973-1978 | 6 | 26 | 24 |
| I | 18Jun 1980 | 1973-1979 | 7 | 1 | 1 |
| I | 22Jun 1980 | 1973-1979 | 7 | 1 | 1 |
| TOTALS | - | - | | 89 | 84 |

Figure 6. Enlargements of acetate peels from three experimental clams showing the middle homogenous layer growth bands. Contrast in the photographs is due to differences in transparency of portions of the peels. Light regions in the photographs correspond to relatively opaque regions of the peel, or those regions which appear dark in actual shell microstructure. Scale bars in each represent 1 mm and growth is to the right.

- A. Experimental clam from lot II (K16) showing the growth disturbances (MDM) caused by measuring and replanting in 1970 (19 Oct 1970) and 1971 (18 Oct 1971). One dark band was formed between these dates and appears as a light band in the photograph. Dating of other prismatic regions (17 Feb and 9 May 1971) was from counts of daily increments.
- B. Experimental clam from lot II (N98) showing the growth disturbance (MDM) caused by measuring and replanting in 1972 (18-20 Sept 1972). Final collection date for this clam was on 25 August 1976. Four dark bands in the middle homogenous layer (marked 1973, 1974, 1975, and 1976) appear as light bands in the photograph. The last dark band (1976) is incomplete and was being formed at the shell margin when clam was collected.
- C. Experimental clam from lot XIV (X251) showing the growth disturbance (MDM) caused by measuring and replanting in 1972 (23-25 Sept 1972). Final collection date for this clam was on 3 January 1978. Five dark bands in the middle homogenous layer (marked 1973, 1974, 1975, 1976, and 1977) appear as light bands in the photograph. A light band was being formed at the shell margin when this clam was collected.

A

19 OCT. 1970

17 FEB. 1971

9 MAY 1971

18 OCT. 1971

SPRING 1972
(Hurricane Agnes)



B

18-20 SEPT. 1972

1973

1974

1975

1976

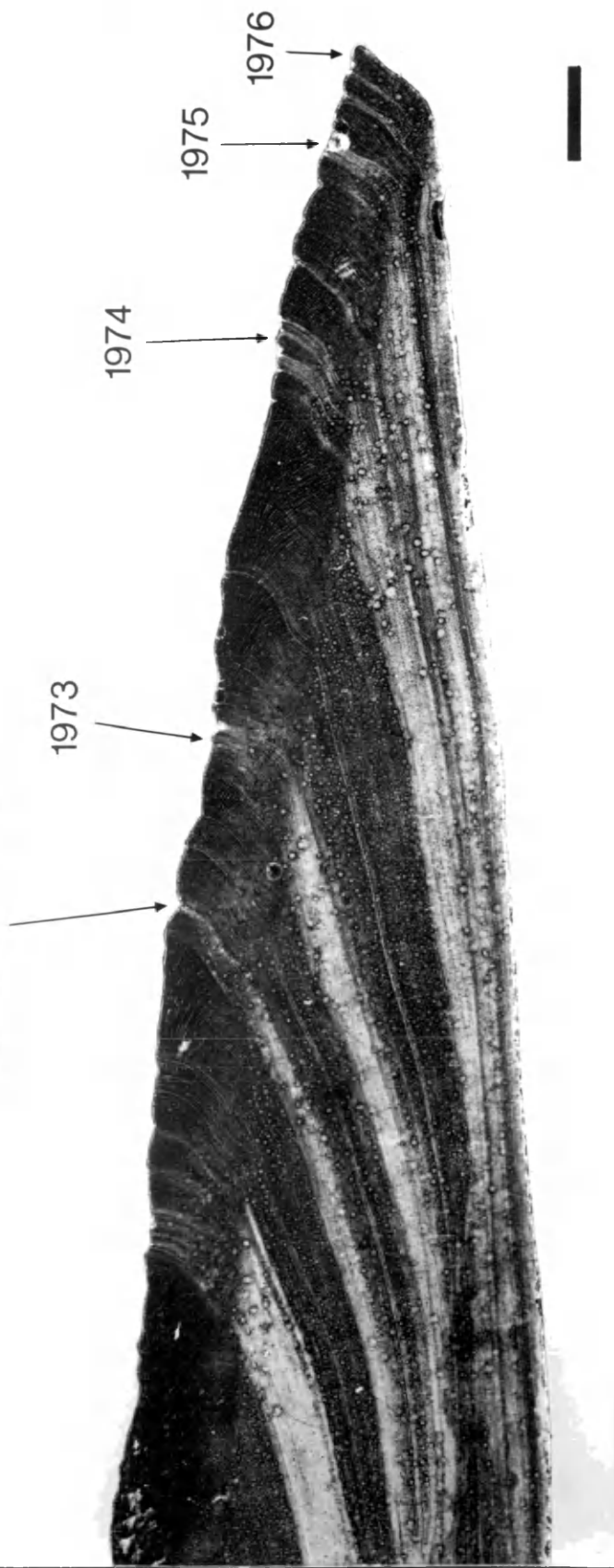

C

23-25 September

1972

1973

1974

1975

1976

1977

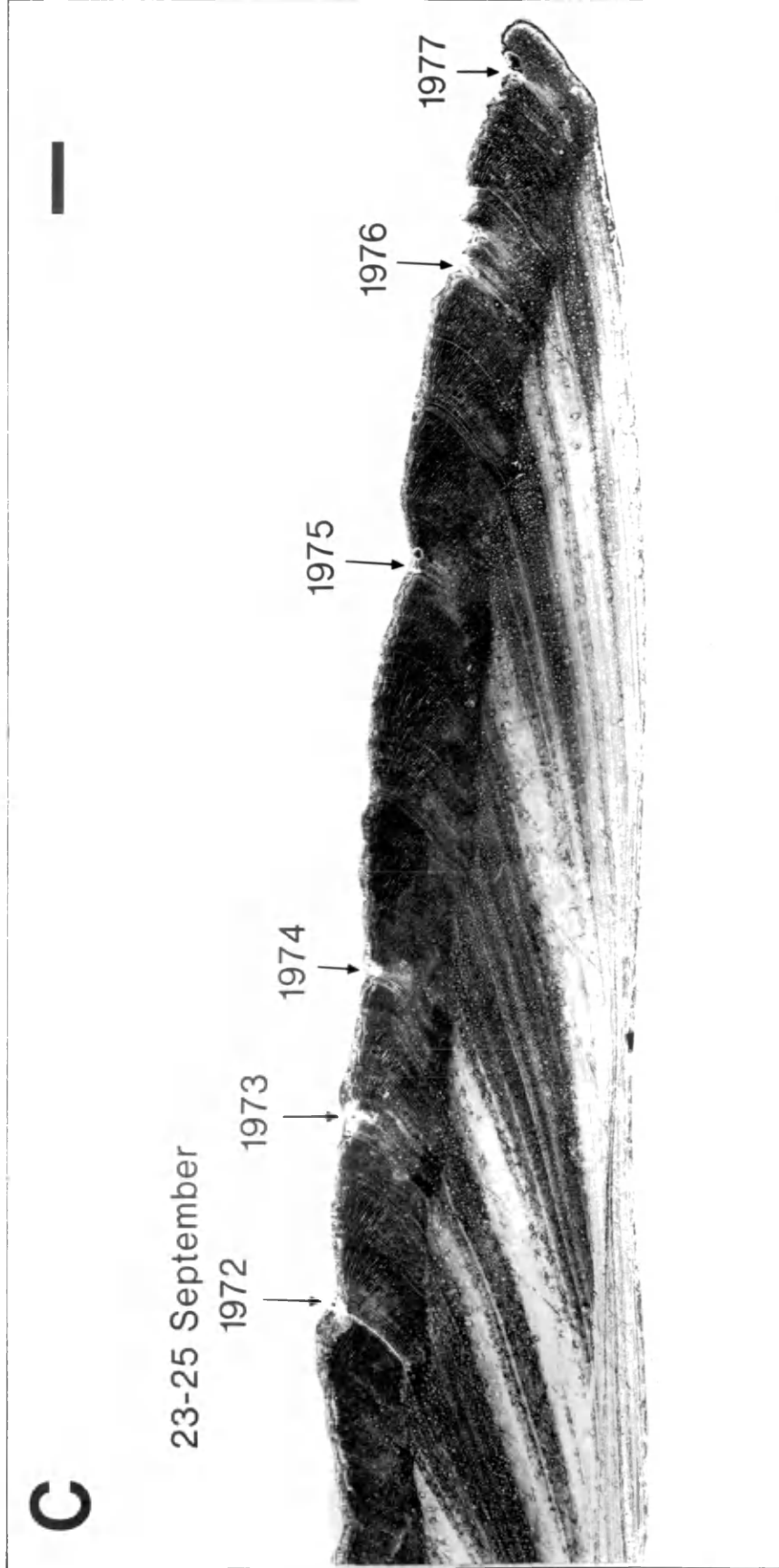

2. Synchrony among experimental clams in lots XI and II in relative width of annual increments from 1973 to 1977

Further support for the contention that dark bands were formed annually was provided by the synchrony among clams in widths of annual increments formed between 1973 and 1977. All clams older than 4 years of age in lots XI (Figure 7A) and II (Figure 8A) had similar patterns of annual increment width measurements from these five years. This result, in itself, does not prove that dark bands were formed annually. However, it does support the contention that the bands in each clam were formed with the same periodicity (Thompson et al. 1980). The exact correspondence of the number of bands and years in 94% of the clams analyzed, as discussed above, provided strong evidence that one dark band was formed each year.

The absolute width of each annual increment tended to decrease as clam age increased. For instance, age 4 clams in each lot had larger annual increments, especially in 1973 and 1974, than older clams (Figures 7A and 8A). Decreased growth rates with age were not unexpected (e.g. Belding 1912; Loesch and Haven 1973). However, comparisons of relative increment size were difficult to make because of the large range in clam age and the decrease in growth rate with age. The percentage which each annual increment represented of total 1973-1977 growth was calculated to obtain results which were independent of the effects of age on absolute annual increment size. This allowed more meaningful comparisons of relative increment size between lots and years.

Figure 7. Annual increments in lot XI clams (n=24) formed between 1973 and 1977. Clams which did not form the expected number of dark bands in the post-1972 period were omitted (Table 3). The ages of clams in 1972 are listed.

- A. Width of annual increments (mm)
- B. Distribution of percent of total 1973-1977 growth represented by each increment for all clams

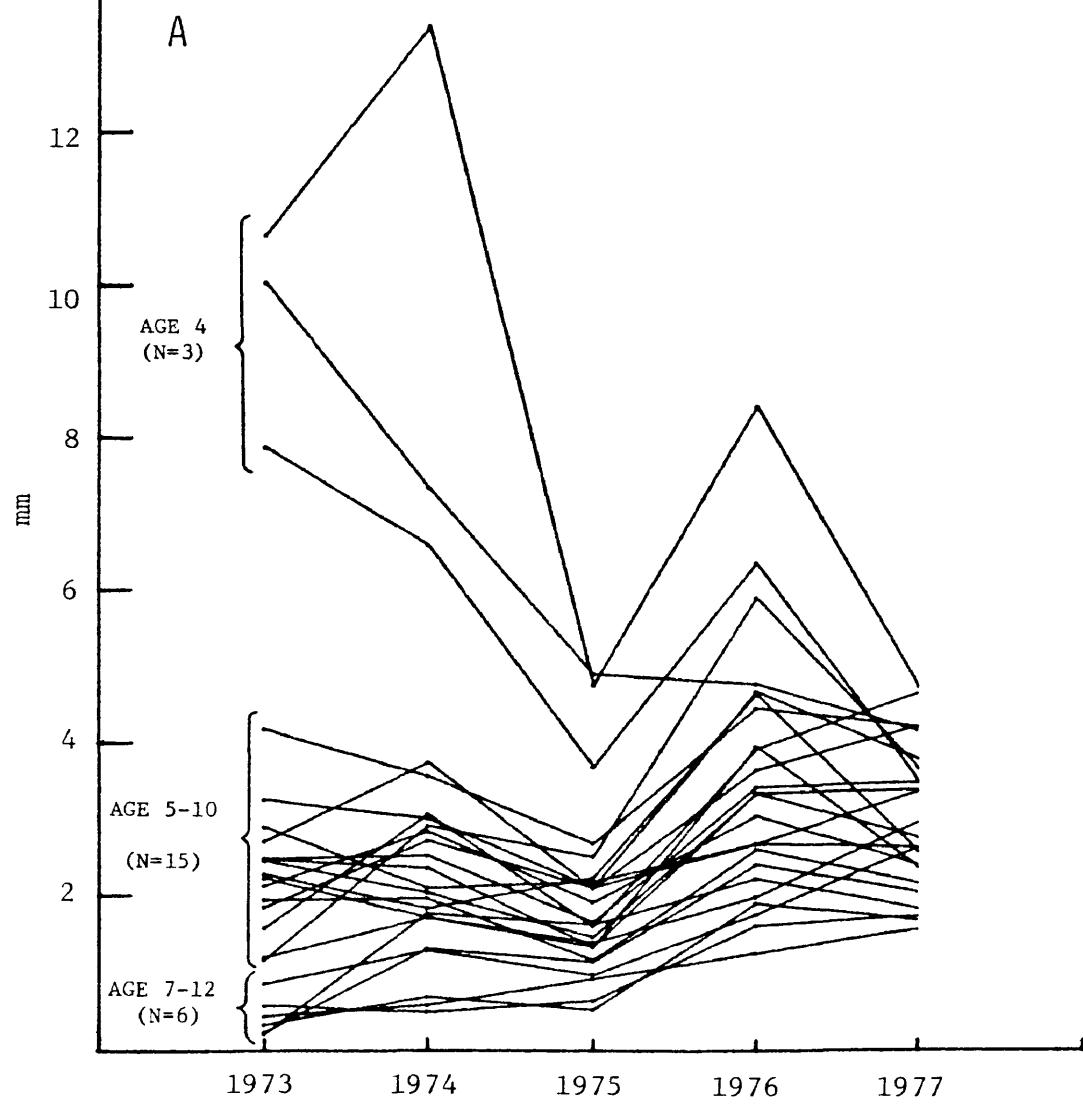
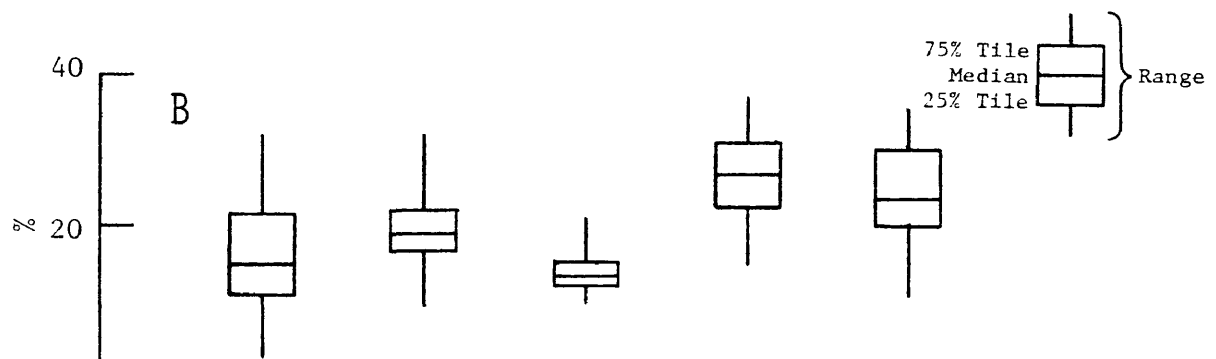
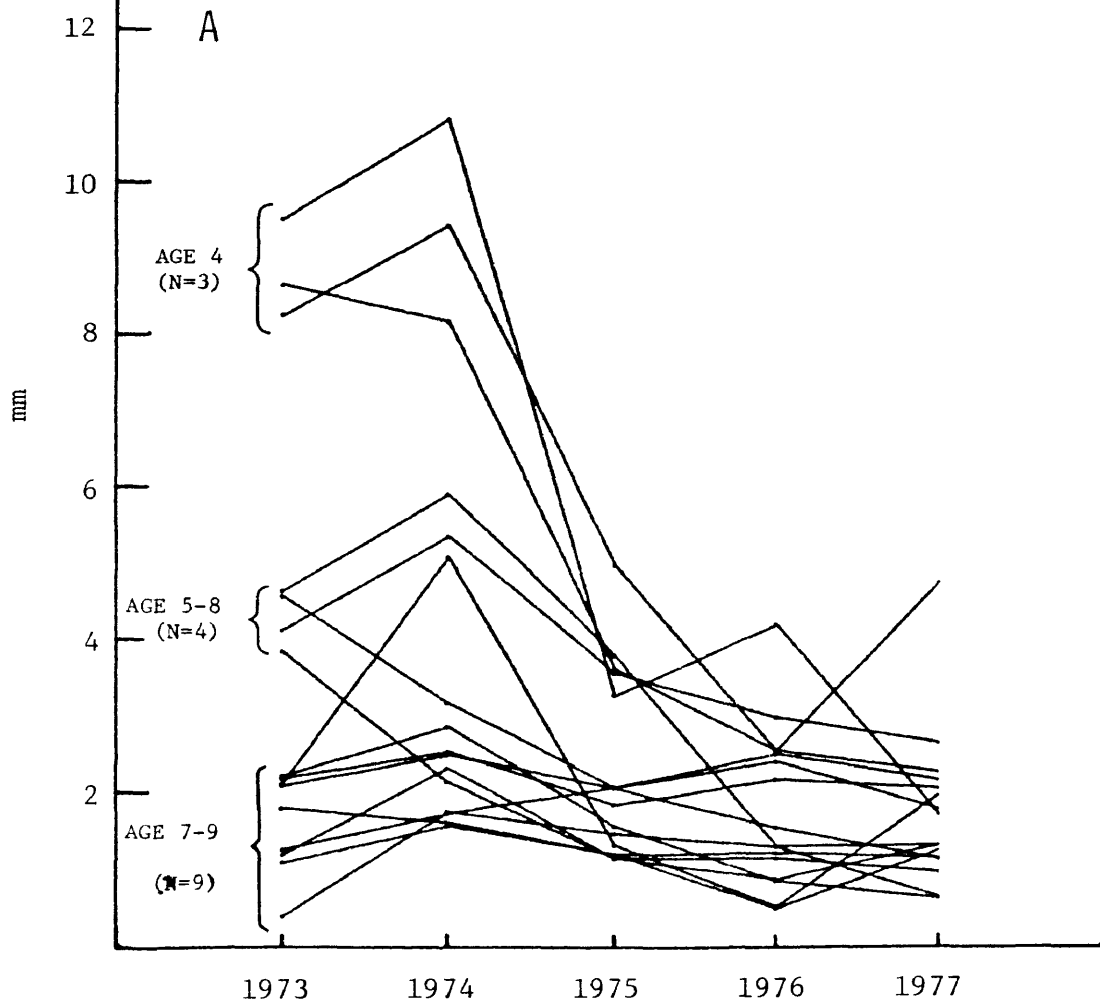
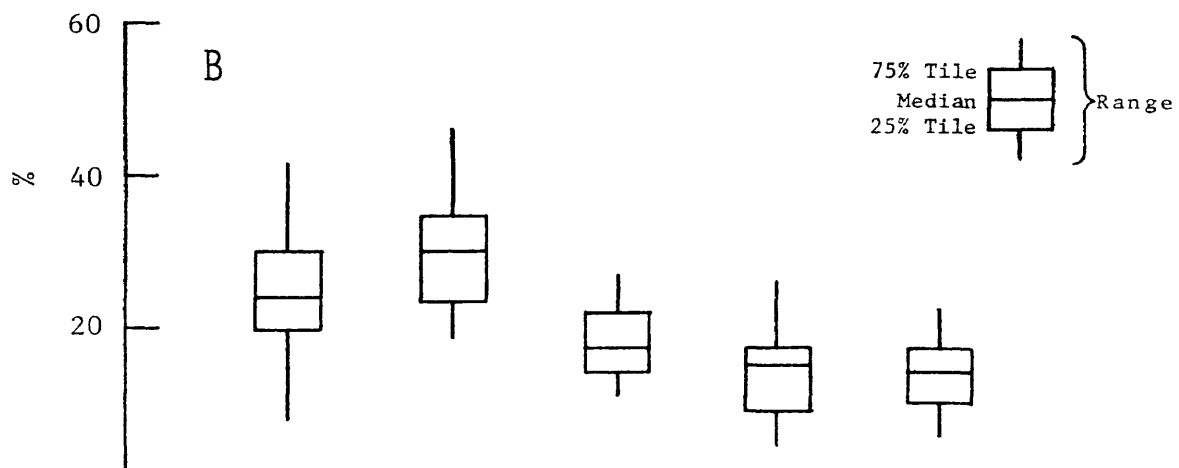

Figure 8. Annual increments in lot II clams (n=16) formed between 1973-1977. Clams which did not form the expected number of dark bands in the post-1972 period were omitted (Table 3). The ages of clams in 1972 are listed.

- A. Width of annual increments (mm)
- B. Distribution of percent of total 1973-1977 growth represented by each increment for all clams



Clams from each lot deposited a median of 50% or more of the total 1973-1977 growth in only two of the five years (Figures 7B and 8B), indicating that these years were more favorable to growth than others. Favorable growth years, however, were different in the two lots. Lot XI clams from the James River (Figure 7B) deposited a median of 50.9% of total 1973-1977 growth in 1976 (26.6%) and 1977 (24.3%). Lot II clams from the York River (Figure 8B) deposited a median of 54.0% of total 1973-1977 growth in 1973 (25.3%) and 1974 (28.7%). Clams in the same lot showed strong synchrony in the percentage of total growth for the period represented by each annual increment. This lends support to the contention that dark bands were formed annually by hard clams.

3. Wild clams in the James and York Rivers

Walford growth equations based on average shell heights at the ventral end of each dark band in wild clams from the James and York Rivers were similar to transformed equations of Haven et al. (1973), which were based on annual morphometric measurements of experimental clams in the two rivers. Again, this in itself does not prove that dark bands were formed annually. However, with the other data presented previously, it supports the contention of annual dark band formation.

Average heights at each dark band in wild stock clams from the James River (Table 4) and York River (Table 5) were used to generate the following Walford growth equations:

$$[1] \quad H_{t+1} = 17.8 + 0.772H_t ; H_{\infty} = 78.1: \text{James}$$

$$[2] \quad H_{t+1} = 14.3 + 0.791H_t ; H_{\infty} = 68.3: \text{York}$$

Table 4. Average height at age for wild clams (\bar{H}_t) sampled from the James River (n=9). Height at age according to the Walford equations derived from this data (text equation [1] and \hat{H}_t') and from the experimental growth lots in James (text equation [6] and \hat{H}_t'' ; Haven et al. 1973) are also shown.

| Age | n | \bar{H}_t | \hat{H}_t' | \hat{H}_t'' |
|-----|---|-------------|--------------|---------------|
| 1 | 8 | 15.0 | 17.8 | 19.4 |
| 2 | 6 | 24.7 | 31.5 | 34.0 |
| 3 | 6 | 40.6 | 42.1 | 44.7 |
| 4 | 5 | 51.7 | 50.3 | 52.7 |
| 5 | 5 | 58.1 | 56.6 | 58.4 |
| 6 | 5 | 63.4 | 61.5 | 62.7 |
| 7 | 4 | 66.6 | 65.2 | 65.8 |
| 8 | 3 | 68.8 | 68.1 | 68.1 |
| 9 | 3 | 70.3 | 70.4 | 69.8 |
| 10 | 3 | 71.5 | 72.1 | 71.0 |
| 11 | 3 | 72.4 | 73.5 | 72.0 |
| 12 | 3 | 73.2 | 74.5 | 72.6 |
| 13 | 3 | 73.6 | 75.3 | 73.1 |
| 14 | 3 | 73.9 | 75.9 | 73.4 |
| 15 | 3 | 74.5 | 76.4 | 73.7 |
| 16 | 3 | 74.8 | 76.8 | 73.9 |
| 17 | 3 | 75.0 | 77.0 | 74.0 |
| 18 | 3 | 75.7 | 77.2 | 74.1 |
| 19 | 2 | 78.2 | 77.4 | 74.2 |
| 20 | 2 | 78.8 | 77.6 | 74.3 |

Table 5. Average height at age for wild clams (\bar{H}_t) sampled from the York River (n=10). Height at age according to the Walford equations derived from this data (text equation [2] and \hat{H}_t') and from the experimental growth lots in the York (text equation [7] and \hat{H}_t'' ; Haven et al. 1973) are also shown.

| Age | n | \bar{H}_t | \hat{H}_t' | \hat{H}_t'' |
|-----|----|-------------|--------------|---------------|
| 1 | 7 | 12.7 | 14.3 | 13.2 |
| 2 | 10 | 23.1 | 25.6 | 24.5 |
| 3 | 10 | 32.6 | 34.5 | 33.6 |
| 4 | 10 | 42.3 | 41.6 | 41.2 |
| 5 | 10 | 47.6 | 47.2 | 47.3 |
| 6 | 10 | 52.1 | 51.6 | 52.3 |
| 7 | 9 | 55.3 | 55.1 | 56.4 |
| 8 | 9 | 57.7 | 57.9 | 59.6 |
| 9 | 9 | 59.4 | 60.1 | 62.4 |
| 10 | 9 | 60.9 | 61.8 | 64.6 |
| 11 | 8 | 62.7 | 63.2 | 66.4 |
| 12 | 7 | 64.1 | 64.3 | 67.9 |
| 13 | 6 | 65.0 | 65.1 | 69.1 |
| 14 | 5 | 65.1 | 65.8 | 70.1 |
| 15 | 4 | 66.2 | 66.3 | 70.8 |
| 16 | 4 | 66.9 | 66.8 | 71.5 |
| 17 | 3 | 66.6 | 67.1 | 72.1 |
| 18 | 3 | 67.2 | 67.4 | 72.5 |
| 19 | 3 | 67.6 | 67.6 | 72.8 |
| 20 | 3 | 67.8 | 67.7 | 73.2 |

The pair of equations derived by Haven et al. (1973), which were based on shell length (L) measurements,

$$[3] \quad L_{t+1} = 21.4 + 0.734L_t ; L_{\infty} = 80: \text{James}$$

$$[4] \quad L_{t+1} = 14.8 + 0.816L_t ; L_{\infty} = 80: \text{York}$$

were converted to height for direct comparison with equations [1] and [2] using the following expression relating shell height to length generated during this study:

$$[5] \quad H = 0.932L - 0.550 ; r = 0.99$$

The equations of Haven et al. (1973), after conversion to height, were as follows:

$$[6] \quad H_{t+1} = 19.4 + 0.734H_t ; H_{\infty} = 72.9: \text{James}$$

$$[7] \quad H_{t+1} = 13.2 + 0.816H_t ; H_{\infty} = 71.7: \text{York}$$

Values of k were the same in the equations before and after conversion to height for clams in each river. This was expected, since asymptotic size is approached at the same rate regardless of the axis of measurement.

Calculated average heights at age of wild clams (equations [1] and [2]; \hat{H}_t' in Tables 4 and 5) and experimental clams of Haven et al. (1973) (equations [6] and [7]; \hat{H}_t'' in Tables 4 and 5) are graphically presented in Figure 9. There is general agreement in the calculated

Figure 9. Height at age according to Walford expressions (see text) of wild clams sampled from the James and York Rivers compared with growth expressions derived from annual measurements of experimental clams in each river (Haven et al. 1973).

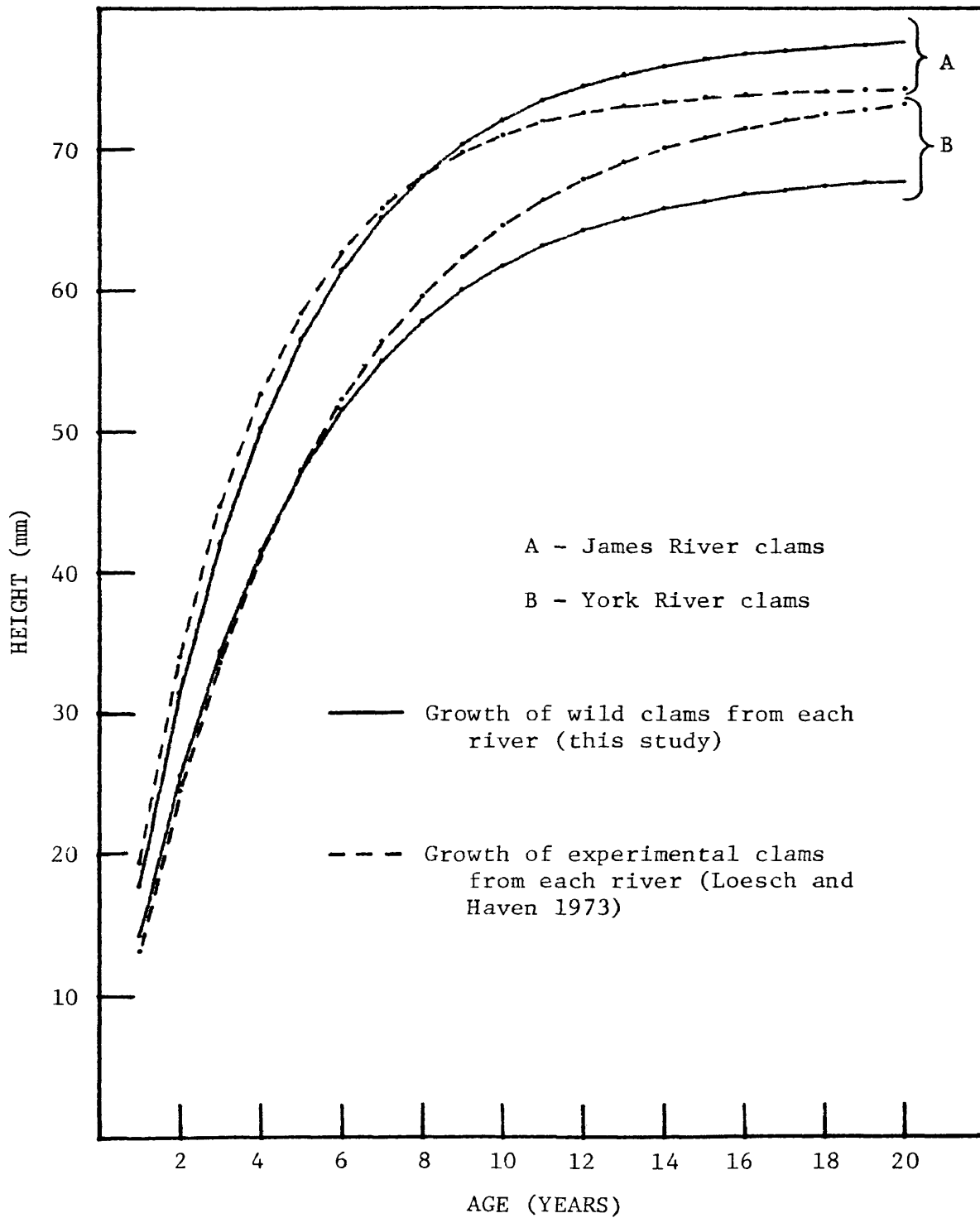

average heights at each age between wild and experimental clams in the same river. However, a consistent feature of both sets of data is the smaller average height at each age of clams in the York than the James River. This comparison shows that growth equations for hard clams from the same area have strong similarities even though they were derived by two different methods. Furthermore, it confirms the reliability of dark bands as expressions of annual periodicities in the shells of hard clams.

Differences observed between the two sets of equations in the two rivers are probably due to large differences in sample size between the two studies and lack of large York River wild clams from this study. To derive their growth expressions, Haven et al. (1973) measured 1573 James River and 1442 York River clams. Equations from this study were based on height measurements of 76 annuli in 9 James River clams and 139 annuli in 10 York River clams. The 10 mm difference in asymptotic height between James and York River wild clams from this study (equations [1] and [2]) was most probably due to lack of clams larger than 70 mm from the York River wild stock collected. This depressed both the values of H_{∞} and k in equation [2].

B. Time of year of annulus formation

Results presented in the previous section (I.A.) strongly suggested that dark bands were annuli in shells of experimental and wild hard clams. In this section, time of year of dark band formation is investigated, assuming only one was formed by any individual each year. Dark bands in the middle homogenous layer were formed most often during

summer and fall in experimental and wild clams from lower Chesapeake Bay. This will be proven through results of analyses of shell margin and fall 'shell margin' growth bands in clams from the four experimental lots, the wild stock, and the T and TI series collected in all seasons. Differences among age groups in shell margin band color in fall and winter were also revealed.

1. Shell margin and fall 'shell' margin growth bands in experimental (lots I, II, XI, and XIV) and wild clams

The percentage of all ages of experimental and wild clams collected in summer which had dark bands at the shell margin (91%) was over twice that of clams collected in winter (40%; Table 6 and Figure 10). As stated previously, incomplete annuli or dark bands at the shell margin were observed most often in experimental clams collected in summer (see Figure 6B). Only 8 clams had final collection dates in spring (Table 1). Three of these (38%) had a dark band at the shell margin (Table 6). No clams had final collection dates in fall. However, fall 'shell margin' growth bands from the 1968 to 1972 monitored growth period provided information on bands at the former shell margins in fall (Table 7). Of the 156 fall 'shell margin' growth bands analyzed, 78% were dark bands (Table 7). This data is also included in Figure 10 under 'ALL AGES' and illustrates that dark bands were at the shell margin most often in summer and fall.

Results presented in Tables 6 and 7 and Figure 10 do not deal with proportions of a group of clams which formed dark bands in each season. These results are presented only to generally summarize

Table 6. Summary of shell margin growth bands in experimental (lots I, II, XI, and XIV) and wild populations of M. mercenaria during seasons of the year. Clams were divided by ages according to Kennish (1980); Young: 0-2 years, Mature: 3-8 years, Old: over 8 years.

| Months of Collection | Season | Age(s) | N | No. With | | % With | |
|----------------------|--------|--------|-----|------------|-----------|------------|-----------|
| | | | | Light Band | Dark Band | Light Band | Dark Band |
| June-Sept | Summer | Young | 3 | 0 | 3 | 0% | 100% |
| | | Mature | 18 | 1 | 17 | 6% | 94% |
| | | Old | 34 | 4 | 30 | 12% | 88% |
| | Total | | 55 | 5 | 50 | 9% | 91% |
| Dec-Feb | Winter | Mature | 6 | 5 | 1 | 83% | 17% |
| | | Old | 39 | 22 | 17 | 56% | 44% |
| | | | 45 | 27 | 18 | 60% | 40% |
| | Total | | | | | | |
| Mar-April | Spring | Mature | 5 | 5 | 0 | 100% | 0% |
| | | Old | 3 | 0 | 3 | 0% | 100% |
| | | | 8 | 5 | 3 | 62% | 38% |
| | Total | | 108 | 37 | 71 | 34% | 66% |

Table 7. Summary of fall 'shell margin' growth bands in experimental clams (lots I, II, XI, and XIV) from 1968 to 1972. Age groups are as defined in Table 6.

| Year | Age | N | Light Band ¹ | Dark Band ² | % Light Band | % Dark Band |
|--------------|--------|-----|-------------------------|------------------------|--------------|-------------|
| 1968 | Mature | 4 | 0 | 4 | 0% | 100% |
| 1969 | Mature | 16 | 5 | 11 | 31% | 69% |
| | Old | 1 | 0 | 1 | 0% | 100% |
| | Total | 17 | 5 | 12 | 29% | 71% |
| 1970 | Mature | 23 | 12 | 11 | 52% | 48% |
| | Old | 2 | 0 | 2 | 0% | 100% |
| | Total | 25 | 12 | 13 | 48% | 52% |
| 1971 | Mature | 40 | 8 | 32 | 25% | 75% |
| | Old | 4 | 0 | 4 | 0% | 100% |
| | Total | 44 | 8 | 36 | 18% | 82% |
| 1972 | Mature | 56 | 10 | 46 | 18% | 82% |
| | Old | 10 | 0 | 10 | 0% | 100% |
| | Total | 66 | 10 | 56 | 15% | 85% |
| GRAND TOTALS | Mature | 139 | 35 | 104 | 25% | 75% |
| | Old | 17 | 0 | 17 | 0% | 100% |
| | Total | 156 | 35 | 121 | 22% | 78% |

¹ Light Band = The number of clams with a light band between the ventral end of the dark band and the MDM.

² Dark Band = The number of clams with the dark band immediately preceding the MDM.

Figure 10. Percent of young, mature, old, and all ages combined of experimental (lots I, II, XI, and XIV) and wild clams with light (unlined) or dark (lined) bands at the shell margin in spring, summer, and winter (data from Table 6). Percent of each age group of experimental clams with light or dark bands in fall based on fall 'shell margin' growth bands at annual measurements between 1968 and 1972 (data from Table 7).

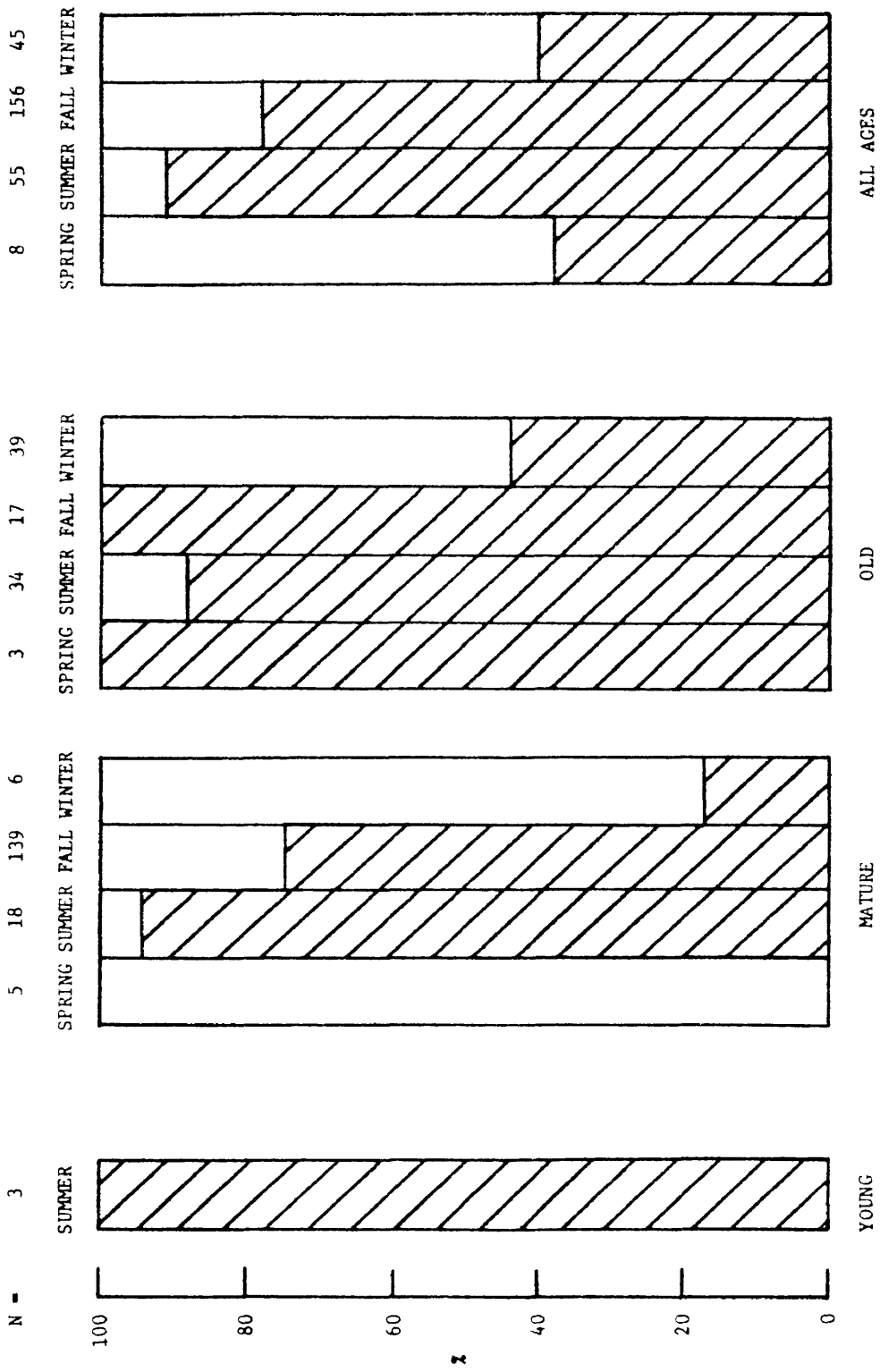

analyses of shell margin and fall 'shell margin' growth bands from several years to determine the season during which dark bands were most often at the shell margin. At no time did 100% of the clams collected in any single season have dark or light bands at the shell margin (Figure 10; ALL AGES). For example, of all clams collected in summer (55), 91% (50) had dark bands at the shell margin, while 9% (5) had light bands. The five clams with light bands were collected in early summer (June), or prior to the onset of dark band formation. Furthermore, one should not assume from this data that clams with dark bands at the margin in winter and spring formed another dark band in summer and fall of the same year. More likely, clams with dark bands at the shell margin in winter and spring stopped growing after the dark band was formed in summer and fall. (This will be discussed further in the next paragraph.) Results in Tables 6 and 7 and Figure 10 were used only to determine the season during which most clams had dark bands at the margin; by inference, this would be the season during which dark bands would most likely be formed.

Further examination of Tables 6 and 7 and Figure 10 reveals differences between age groups in the color of shell margin growth bands in fall and winter. The percentage of clams in all age groups forming dark bands at the shell margin in summer ranged between 88-100% (Table 6 and Figure 10). However, in fall and winter, differences between age groups began to appear. In fall, 100% of old and 75% of mature clams had dark bands at the shell margin (Table 7 and Figure 10). The percentage with dark bands in winter declined in both age groups, but was still larger in old (40%) than mature (17%) clams. This indicates that light band formation began sooner (after the summer dark band was

completed) in a greater percentage of mature than old clams. This could also be a result of a lack of growth by old clams in fall and winter. Dark bands at the shell margins of old clams during these seasons may then have been formed in summer. This will be discussed further in Results sections I.C. and II.C.

2. Shell margin growth bands and band width measurements in T and TI clams

Dark bands were observed at the shell margin only in T and TI clams collected in summer (Table 8). Twenty clams were collected in the summer of 1980 (June through September). The percentage at each collection forming dark bands increased from 0% in June, to 86% and 100% in July and August, and decreased to 71% and 0% in September and November, respectively. Of the 7 clams collected during the summer of 1981, four (57%) were forming dark bands at the shell margin in June (Table 8). Thus, dark band formation by T and TI clams began one month earlier in the summer of 1981 than in 1980. This will be discussed in more detail in section II.B.2.c. of Results. During the remainder of the year (fall, winter, and spring), a light band was at the shell margin of T and TI clams (Table 8).

A typical series of seasonal shell margin growth bands from this group is shown in Figure 11A-E. These photographs span 10 months of shell growth by the group from 8 August 1980 (collection date of the clam in Figure 11A) to 27 June 1981 (collection date of the clam in Figure 11E). The first three photographs (Figure 11A-C) show shell margins as they appeared in summer, fall, and winter. The dark band, which was at the shell margin in August (Figure 11A), was replaced at

Table 8. Growth bands in T and TI clams from 16 October 1979 to date of collection. Growth bands at the shell margin and average width of each growth band along the SMG from the growth disturbance of 16 October 1979 to the date of collection are also shown. Growth bands: LB = light band; DB = dark band.

| Date of Collection | Shell Margin Growth Band | | | | Average Width (μm) of Each Growth Band | | | | | | | |
|-----------------------|--------------------------|----|----|------|---|----------------|--------|----------------|----|---------------------------|----|----------------|
| | N | LB | DB | % LB | % DB | Spring 1980 | | Summer 1980 | | Fall 1980- Spring 1981 | | Summer 1980 |
| | | | | | | LB | DB | LB | DB | LB | DB | |
| 5 Apr 1980 | 3 | 3 | 0 | 100 | 0 | 223.2 | -- | -- | -- | -- | -- | -- |
| 29 May 1980 | 4 | 4 | 0 | 100 | 0 | 993.6 | -- | -- | -- | -- | -- | -- |
| 22 Jun 1980 | 3 | 3 | 0 | 100 | 0 | 1468.8 | -- | -- | -- | -- | -- | -- |
| 18 Jul 1980 | 7 | 1 | 6 | 14 | 86 | 1430.2 | 999.0 | -- | -- | -- | -- | -- |
| 8 Aug 1980 | 3 | 0 | 3 | 0 | 100 | 2016.0 | 1148.4 | -- | -- | -- | -- | -- |
| 13 Sep 1980 | 7 | 2 | 5 | 29 | 71 | 1849.9 | 2121.4 | 2127.6 | -- | -- | -- | -- |
| 1 Nov 1980 | 4 | 4 | 0 | 100 | 0 | 2254.5 | 4039.2 | 1695.6 | -- | -- | -- | -- |
| 4 Dec 1980 | 4 | 4 | 0 | 100 | 0 | 1117.8 | 3628.8 | 1344.6 | -- | -- | -- | -- |
| 31 Jan 1981 | 4 | 4 | 0 | 100 | 0 | 1846.8 | 3747.6 | 2532.6 | -- | -- | -- | -- |
| 14 Mar 1981 | 4 | 4 | 0 | 100 | 0 | 2664.9 | 4900.5 | 2627.1 | -- | -- | -- | -- |
| 4 Apr 1981 | 4 | 4 | 0 | 100 | 0 | 3339.9 | 4160.7 | 2427.3 | -- | -- | -- | -- |
| 31 May 1981 | 4 | 4 | 0 | 100 | 0 | 1838.7 | 2440.8 | 4463.1 | -- | -- | -- | -- |
| 27 Jun 1981 | 7 | 3 | 4 | 43 | 57 | 2301.9 | 3025.5 | 6847.2 | -- | -- | -- | 580.5 |

Figure 11. Enlargements of acetate peels from five T and TI clams showing growth from the transplantation in October 1979 to the date of collection (shell margin). Growth disturbance due to the transplantation labelled fall-winter 1979-1980. The middle homogenous layer growth bands are labelled lb (light band) and db (dark band). See Figure 6 for explanation of contrast in photographs. Scale bars in each represent 1 mm and growth is to the right. op - outer prismatic layer; mh - middle homogenous layer.

- A. TI clam (T60) collected in summer (8 August 1980) showing dark band (db) at the shell margin.
- B. T clam (T112) collected in fall (1 November 1980) showing light band (lb) at the shell margin.
- C. T clam (T119) collected in winter (31 January 1981) showing light band (lb) at the shell margin.
- D. T clam (T75) collected in spring (31 May 1981) showing light band (lb) at the shell margin and a distinct winter growth cessation (w) within this light band.
- E. TI clam (T38) collected in early summer (27 June 1981) showing light band (lb) at the shell margin with no distinct winter growth cessation within it.

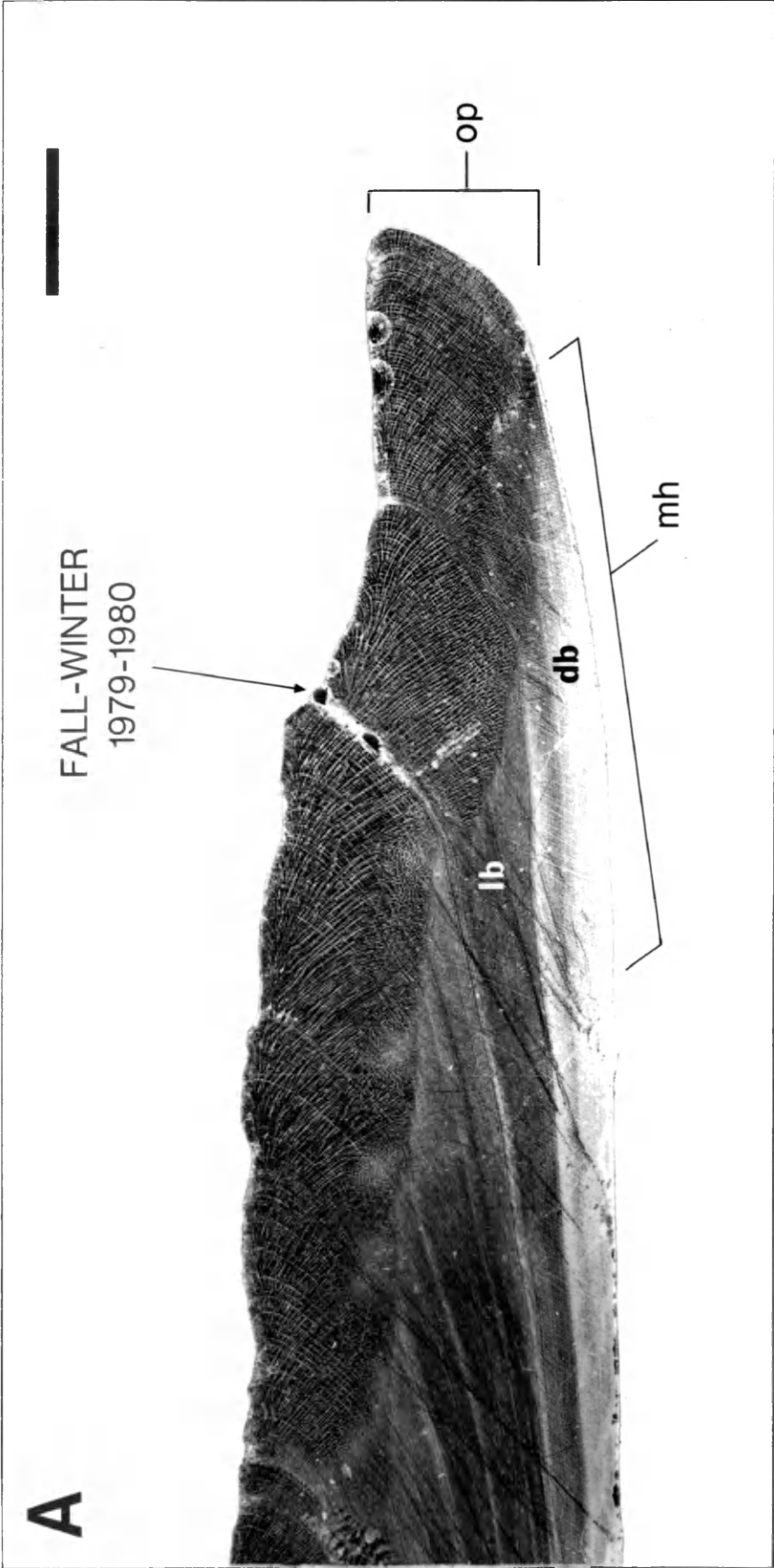

B

FALL-WINTER
1979-1980

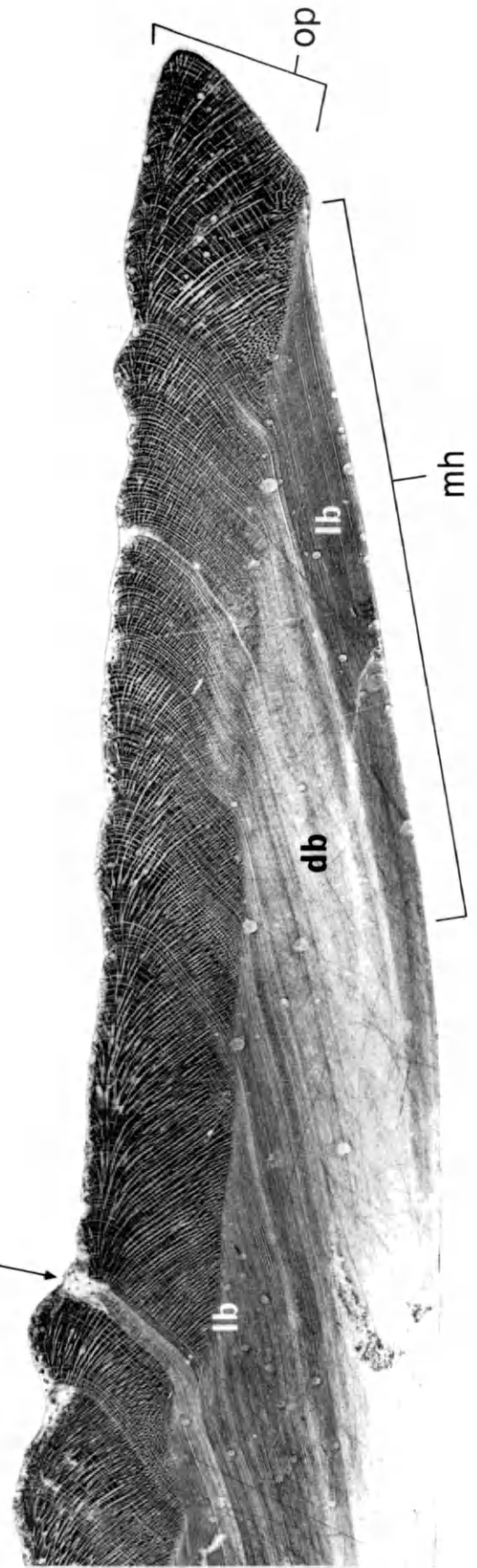

C

FALL-WINTER
1979-1980



D

FALL-WINTER
1979-1980



E

FALL-WINTER
1979-1980



db

lb

mh

op

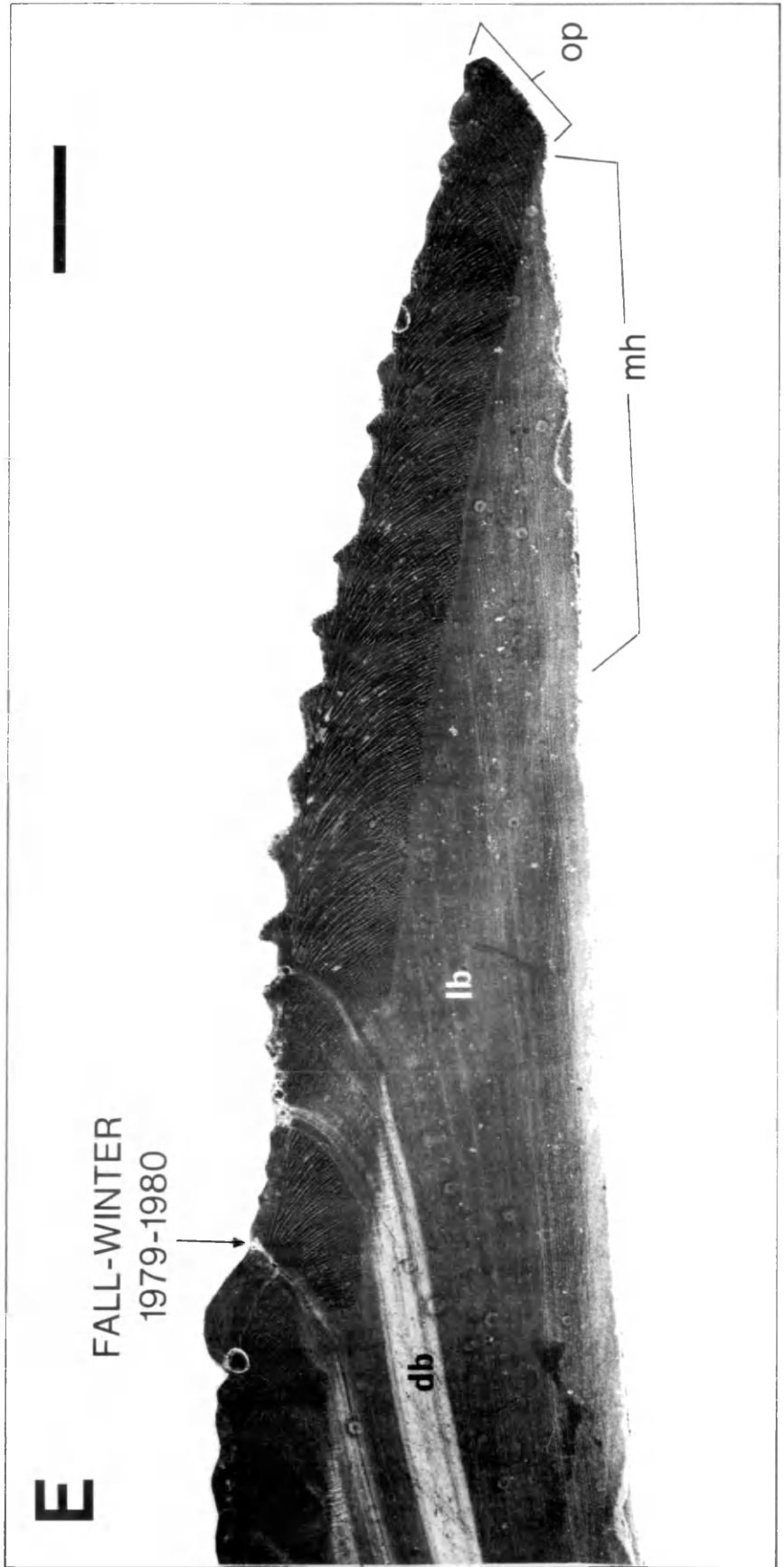

the margin by a light band prior to November (Figure 11B). A light band was also at the shell margin in January (Figure 11C). Figure 11D and E represent shell margins of two clams collected in May and June 1981, respectively. Both clams had a light band at the shell margin. However, this light band appears differently in the two clams. The shell margin light band of the clam in Figure 11D is bisected by a growth cessation mark formed during the winter of 1980-1981. This mark, termed a distinct winter growth cessation, is approximately equivalent to the shell margin of the clam collected in winter (Figure 11C). No such mark bisects the shell margin light band of the clam in Figure 11E. Distinct winter growth cessations and their significance in hard clam shell growth analysis will be discussed again in section II.B.2.d. of Results.

The average width of each band on the SMG increased with each collection during the period of its formation (Table 8; averages connected by lines in Figure 12). A light band was at the shell margin of all clams collected in April through June 1980 (Table 8). The average width of this fall 1979-spring 1980 light band increased during this same period from 223.2 μm in April to 1468.8 μm in June (Table 8; averages connected by lines in Figure 12). However, in July, a dark band replaced the fall 1979-spring 1980 light band at the shell margin. The average width of the summer 1980 dark band increased from 999.0 μm to 4039.2 μm from July to November, when it was replaced at the shell margin by a light band (Table 8; averages connected by lines in Figure 12). The average width of the fall 1980 to spring 1981 light band did not increase appreciably in any clams collected from September 1980 through April 1981, despite the fact that it was the band

Figure 12. Average (horizontal bar) and range (vertical bar) of the width of each growth band (in μm) in the T and TI clams sampled from 5 April 1980 to 27 June 1981 (n=58; data from Table 8). Number of clams represented by each bar is in parentheses. Averages connected by lines were calculated from collections made during the time of formation of each band. Unconnected averages in the light band of spring 1980 and the dark band of summer 1980 were calculated from collections after the band was formed and other band(s) separated it from the shell margin.

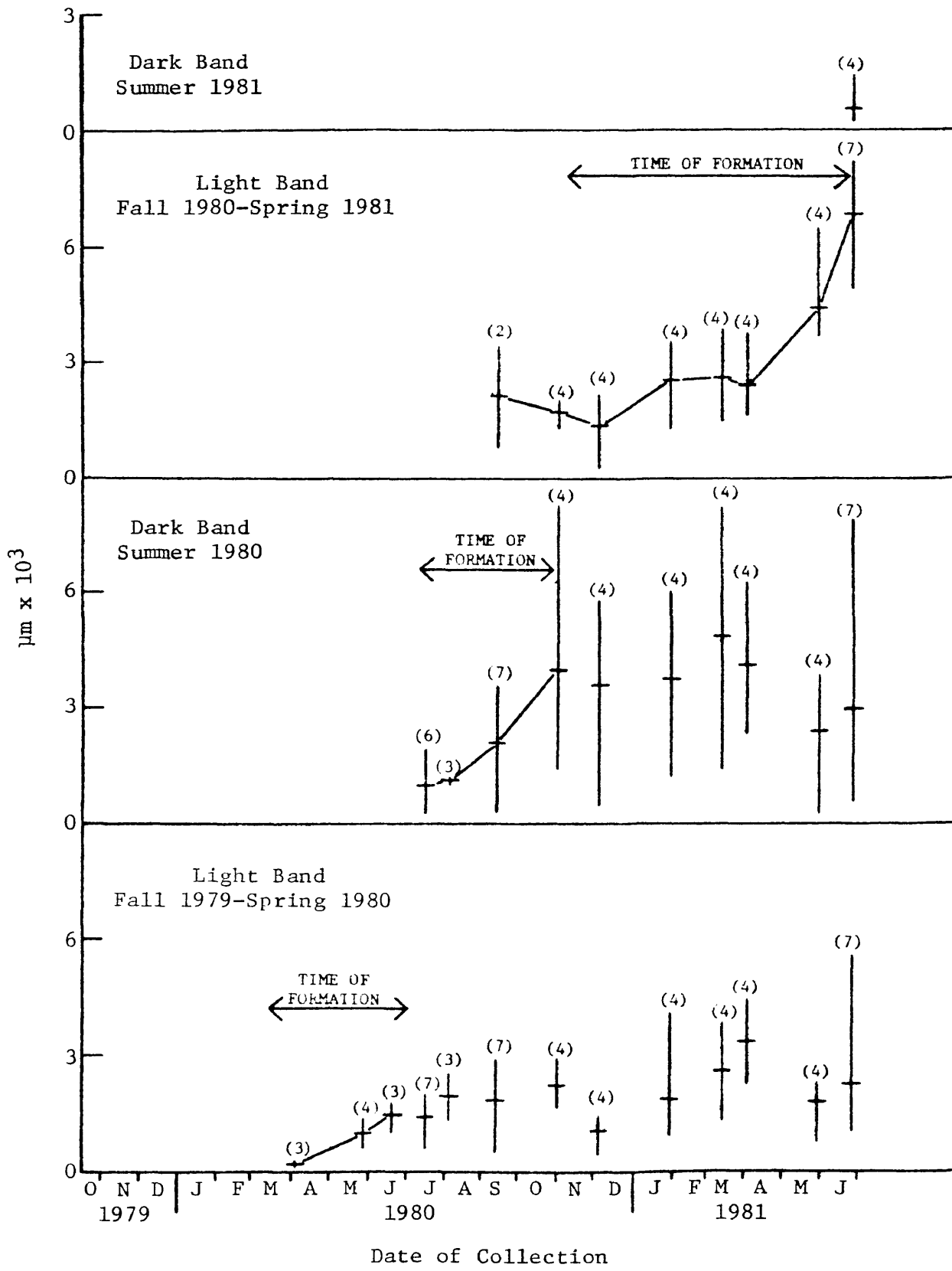

at the shell margin. However, from April through June 1981, the average width of this light band increased from 2427.3 μm to 6847.2 μm (Table 8; Figure 12).

Average widths of the fall 1979-spring 1980 light band and summer 1980 dark band varied widely in clams from collections taken when neither band was at the shell margin (unconnected averages in Figure 12). The range in band width in clams collected after the band was completed could only have been due to individual variability in absolute seasonal growth. For instance, the fall 1979-spring 1980 light band in clams collected on 4 April 1981 represented growth during the fall through spring of 1979-1980. Clams collected on 4 April 1981, however, happened to have had fall 1979-spring 1980 light bands with over twice the average width (3339.9 μm ; Table 8) of those collected in June or July 1980 (1468.8 and 1430.2 μm , respectively; Table 8), or when this light band ceased being the shell margin growth band. This large variation in average width of previously formed and completed bands must have been due to individual variability in absolute growth during the season of band formation.

C. Age determination of Mercenaria mercenaria from lower Chesapeake Bay

Data presented in sections I.A. and I.B. above have shown that dark bands in the middle homogenous layer of M. mercenaria from lower Chesapeake Bay were formed only once each year during summer and fall, and thus, fit the definition of annuli. During the remaining seasons (winter and spring), light bands were formed. However, differences among age groups in seasonal duration of dark band formation

were also apparent. Mature and young clams (those less than 8 years old) confined the period of dark band formation to the summer months. Older clams, however, either extended the period of dark band formation into fall and winter, or did not grow during this period. In the latter case, the dark band at the shell margin in fall and winter in older clams may actually represent summer and early fall growth and lack of growth in late fall and winter.

The age of a hard clam is determined by counting annuli or dark bands in shell microstructure. However, the month of collection must also be known to assign a year to the last annulus formed. For instance, assume two clams (A and B) were collected in March. Clam A has 5 complete annuli and a light band at the shell margin. The last complete annulus is assigned to the previous summer, while the light band at the shell margin represents growth from the previous fall through March. Thus, clam A is said to be 5+ years old. Clam B has 16 complete annuli and a dark band, or incomplete annulus, at the shell margin. The incomplete annulus is also assigned to the previous summer since old clams are less likely to form light bands in fall and winter. Consequently, clam B is said to be 17+ years old. Since hard clams in lower Chesapeake Bay spawn in spring (Castagna and Kraeuter 1981), an artificial birthdate of 1 May is also used in assigning integer years to age.

The definition of single dark bands is clearest when clams are between 3 and 15 years of age (see Figures 6A, 6C, and 11). Dark bands and the annual shell increments which they define are difficult to discern in clams older than 15 years due to their narrow width, and in clams younger than 3 years, due to their large width and pale, often

diffuse appearance. To determine the age of older clams, an objective technique was devised to distinguish between true annuli and large growth disruptions due to other causes, most notably cold water temperatures during winter. True annuli in clams older than 15 years are separated from each other by narrow light bands or discontinuities in the region where the inner and middle homogenous layers meet. For instance, in Figure 6B, three complete dark bands corresponding to the summers of 1973, 1974, and 1975 are labelled. The dark band of 1975 is separated from that of 1974 by a thin light band or discontinuity in the region where the two homogenous layers meet. Consequently, these two dark bands represent true annuli. However, there is a growth disruption approximately 0.6 mm ventral (toward the shell margin) to the dark band of 1974 and separated from it by a light band. This growth disruption could be mistaken for an annulus. By following the thin dark stripe associated with this growth disruption into the middle homogenous layer, one finds that it merges with the dark band of 1974. Consequently, the growth disruption does not represent a true annulus, but more likely a growth cessation during the winter of 1974-1975. The light band separating it from the dark band would then have been formed in the fall of 1974. This method was found to be essential in determining the age of almost all clams older than 15 years.

Identification of the first two annuli of hard clams, young and old, also required supplementary techniques. In young clams, annuli are usually wide and diffuse, which makes positive identification difficult, while the first several annuli of old clams are often eroded from shell microstructure. Three additional methods were useful in

assigning age to young, or identifying the first several annuli of old clams:

- 1) The total shell height of a young clam or the shell height at the first recognizable annulus of an old clam was compared with the average shell heights at age of clams from the same general geographic area (as in Tables 4 and 5). Age was then assigned to a young, or an annulus of an old clam based on the similarity of the height measurements to calculated average values at each age.
- 2) The dark band representing the first recognizable annulus was followed through the inner homogenous layer back to the umbo. The umbo region also has a record of growth history within it, but its small size made distinguishing individual dark bands difficult. However, the first several annuli were usually well separated by light bands here. Age was assigned to a designated annulus in the middle homogenous layer by counting the number of wide dark bands formed previously to it in the umbo region.
- 3) Daily increments were counted in as large a portion of shell microstructure of a young clam as possible. In this manner, an estimate of the age in days was obtained and age in years calculated from it. This method cannot be used in old clams since the prismatic layer in the umbonal region was often eroded from the shell. As will be discussed in section II.A.3. of Results, the relationship of daily increments to annual shell increments varies greatly among individual clams, which makes the accuracy of this method questionable.

II. Daily increments and analysis of growth history in Mercenaria mercenaria

Daily increments in the prismatic layer were analyzed for two purposes: 1) to determine the periodicity of their formation by lower Chesapeake Bay hard clams, and 2) to analyze the relationship between daily increments and bands in the middle homogenous layer. Data for both purposes consisted of daily increment counts in known shell growth

periods. Growth rate determinations, as well as analyses of growth disturbance marks were included in 2) above, to detail seasonal growth.

A. Periodicity of increment formation

Three sets of increment counts from experimental clams were used to determine the periodicity of their formation and describe the relationship between them and monitored periods of growth:

- 1) The number of increments from the growth disturbance of 29-30 May 1980 to the shell margin in four collections of TI clams during the summer of 1980,
- 2) The total number of increments from the growth disturbance due to transplantation of the T and TI clams to the shell margin in all but one clam collected on or after 5 April 1980, and
- 3) The number of increments between MDM's formed one year apart between 1968-1972 by clams in lots XI and II.

The last set of increment counts were also related to the age of each clam and the effects of tropical storm Agnes on shell growth in 1972 (see Results section II.B.1.c.).

The results indicated that experimental clams formed one increment during each solar day that the clams were active. However, inactive periods, which were represented by growth cessation marks, became longer with increasing age. When clams were active and growing, though, one increment was formed each solar day. Furthermore, as monitored growth periods increased to include one or more winters (as in the T and TI clams), growth cessations of varying durations decreased

the number of increments formed. Consequently, the 1:1 increment-to-day relationship was strongest in short periods (1-4 months) of monitored shell growth by young (age 3+) hard clams during the growing season (spring to fall), and did not hold over longer periods in clams of any age.

1. TI series - from 29-30 May 1980

Twelve TI clams collected on 4 dates in the summer of 1980 had a strong tendency to form one increment each solar day during the experimental period (Table 9; ANOVA presented in Table 10; Figure 13). Results of the ANOVA indicated highly significant differences in counts among sampling dates ($F=52.72$, $P<.001$), as well as a highly significant proportion of that difference explainable by a linear relationship ($F=156.30$, $P<.001$, $r=0.98$). The regression coefficient (1.10) was not significantly different from 1.00 ($t_s=1.23$, $P>.20$). This is strong evidence that hard clams form one prismatic increment each solar day, at least during the summer.

2. T and TI series - from transplantation
(16 October 1979)

Fifty-eight T and TI clams collected on or after 5 April 1980 until 27 June 1981 also tended to form one increment each solar day of activity (Table 11; ANOVA presented in Table 12; Figure 14). The results of the ANOVA indicated highly significant differences in counts among sampling dates ($F=15.05$, $P<.001$) as well as a highly significant proportion of that difference due to a linear relationship ($F=177.25$,

Table 9. Number of daily increments (average and range of three clams) in TI-clams from disturbance mark of 30 May 1980 to the shell edge in four collections from summer, 1980. The clams were collected on 29 May 1980, placed in a 4°C incubator for 24 hours, replanted on 30 May 1980 and collected again on the following dates.

| Collection Date | Sampling Time | Cumulative No. of Solar Days | Average | Range |
|-----------------|---------------|------------------------------|---------|-----------|
| 5/30/80 | planting | 0 | -- | -- |
| 6/22/80 | TI-1 | 23 | 25 | 24 - 26 |
| 7/18/80 | TI-2 | 49 | 46 | 34 - 53 |
| 8/ 8/80 | TI-3 | 70 | 69 | 64 - 74 |
| 9/13/80 | TI-4 | 106 | 116 | 110 - 126 |

Table 10. Analysis of Variance (Regression) of Number of Increments on the Number of Days in the TI (1-4) Clams (n = 12) and Testing of Regression Coefficient ($\beta = \beta_0 = 1$) with 95% Confidence Limits on b. Data From Table 9.

A. ANOVA Table

| Source of Variation | df | SS | MS | F |
|-----------------------------|----------|---------------|-----------|------------------|
| Among Sampling Dates | 3 | 13,686.25 | 4,562.08 | 52.72*** P<.001 |
| Linear Regression | 1 | 13,524.81 | 13,524.81 | 156.30*** P<.001 |
| Deviations from Regression | 2 | 161.44 | 80.72 | 0.93 n.s. P>.25 |
| Within Clams From Each Date | <u>5</u> | <u>432.67</u> | 86.53 | |
| TOTAL | 11 | 14,118.92 | | |

B. Regression equation: Y = No. of Increments

X = No. of Days in Period

$$\hat{Y} = 1.10 X - 4.40; r = 0.98$$

C. Testing of Slope ($\beta = \beta_0 = 1$)

1) Standard Error of Regression Coefficient

$$S_b = \sqrt{\frac{S^2_{y.x}}{\sum X^2}} = \sqrt{\frac{80.72}{11,070}} = 0.085$$

2) t-test (df = 10)

$$t_s = \frac{b-1}{S_b} = \frac{1.10-1}{0.085} = 1.23 \text{ n.s. } P>.20$$

3) 95% Confidence Limits on Regression Coefficient

$$t_{.05} [10] S_b = 2.228 (0.085) = 0.19$$

$$1.10 - 0.19 = 0.90$$

$$1.10 + 0.19 = 1.29$$

Figure 13. Average and range (as in Figure 12) of the number of increments in TI clams after the growth disturbance of 29-30 May 1980 to the shell margin (data from Table 9). Solid Line: regression; Dashed Lines: $\pm 95\%$ confidence limits on regression coefficient (see Table 10).

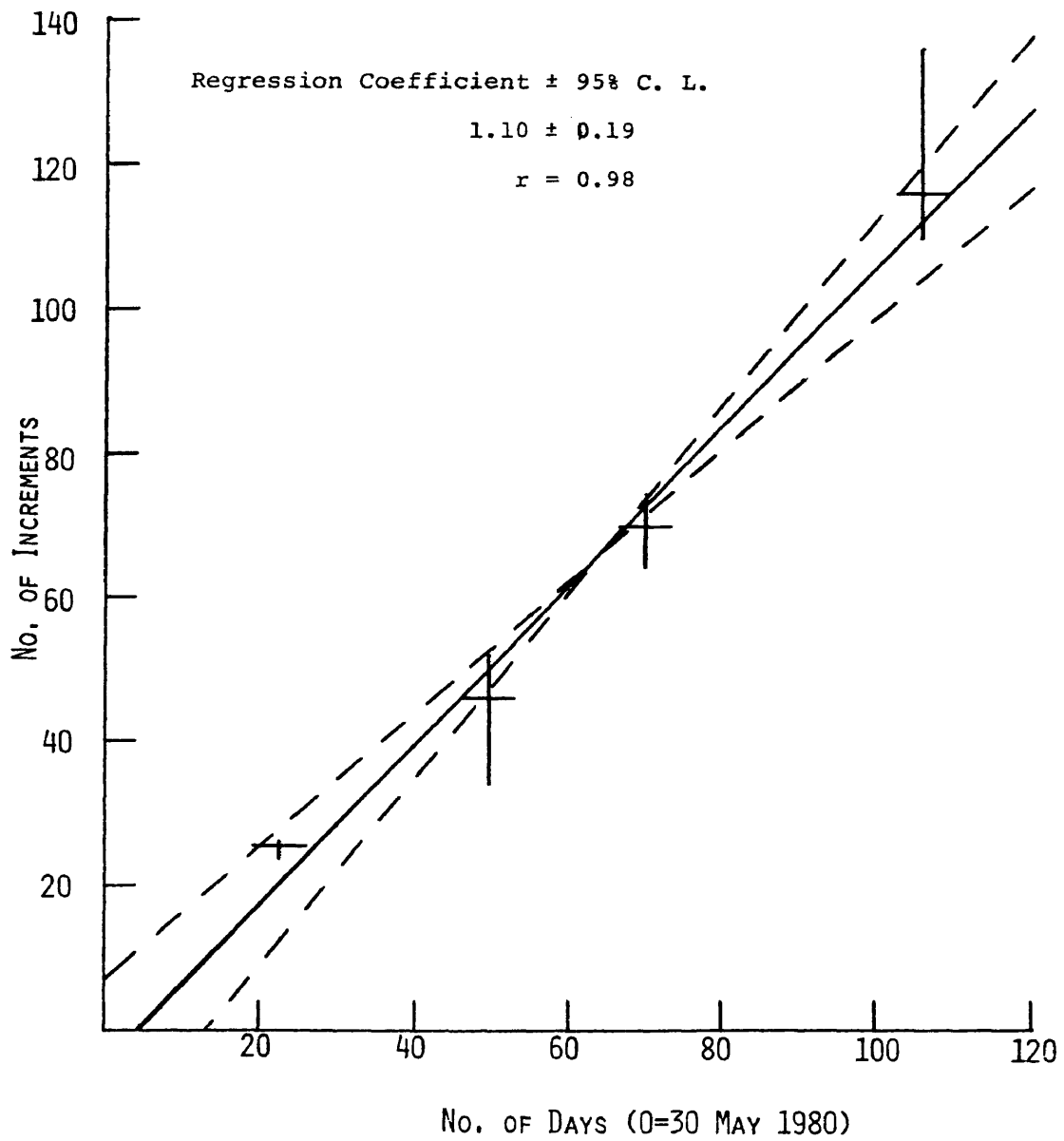

Table 11. Number of Daily Increments (Average and Range) in All T and TI-Clams From Disturbance Mark of 16 October 1979 to the Shell Margin.

| Collection Date | Sampling Time | n | No. With Increments | Cumulative No. of Solar Days | No. of Increments Average ¹ | Range |
|-----------------|---------------|---|---------------------|------------------------------|--|---------|
| 10/16/79 | t= 0 | 4 | 0 | 0 | 0 | - |
| 10/25/79 | 1 | 4 | 0 | 9 | 0 | - |
| 11/ 4/79 | 2 | 4 | 0 | 19 | 0 | - |
| 11/17/79 | 3 | 4 | 2 | 32 | 14 | 0- 14 |
| 12/ 4/79 | 4 | 4 | 3 | 46 | 21 | 0- 29 |
| 2/ 2/80 | 5 | 4 | 1 | 109 | 12 | 0- 12 |
| 4/ 5/80 | 6 | 4 | 3 | 172 | 22 | 0- 26 |
| 5/29/80 | 7 | 4 | 4 | 226 | 64 | 32- 79 |
| 6/22/80 | TI-1 | 3 | 3 | 2492 | 83 | 85- 97 |
| 7/18/80 | TI-2 | 3 | 3 | 2752 | 121 | 111-127 |
| 7/18/80 | 8 | 4 | 4 | 276 | 95 | 68-123 |
| 8/ 8/80 | TI-3 | 3 | 3 | 2962 | 129 | 118-137 |
| 9/13/80 | TI-4 | 3 | 3 | 3322 | 201 | 184-215 |
| 9/13/80 | 9 | 4 | 4 | 333 | 144 | 90-183 |
| 11/ 1/80 | 10 | 4 | 4 | 382 | 272 | 205-376 |
| 12/ 4/80 | 11 | 4 | 4 | 415 | 224 | 132-277 |
| 1/31/81 | 12 | 4 | 4 | 473 | 305 | 184-398 |
| 3/14/81 | 13 | 4 | 4 | 515 | 351 | 246-453 |
| 4/ 4/81 | 14 | 4 | 4 | 536 | 412 | 393-424 |
| 5/31/81 | 15 | 4 | 4 | 593 | 332 | 232-451 |
| 6/27/81 | TI-5 | 3 | 3 | 6192 | 366 | 318-403 |
| 6/27/81 | 16 | 4 | 4 | 620 | 438 | 311-579 |

¹ Average number of increments in those clams with increments.

² The growth of the TI-series was interrupted on 29 May 1980 for 1 day. The number of days of growth was reduced by 1.

Table 12. Analysis of Variance (Regression) of Number of Increments on the Number of Days in T and TI-Clams (t = 6 to t = 16; n = 58) and Testing of the Regression Coefficient ($\beta = \beta_0 = 1$) with 95% Confidence Limits on b. Data From Table 11.

A. ANOVA Table

| Source of Variation | df | SS | MS | F |
|-----------------------------|-----------|-------------------|------------|-----------------|
| Among Sampling Dates | 15 | 966,777.58 | 64,451.84 | 15.05***P<.001 |
| Linear Regression | 1 | 896,008.57 | 896,008.57 | 177.25***P<.001 |
| Deviations from Regression | 14 | 70,769.01 | 5,054.93 | 1.18 n.s.P>.25 |
| Within Clams From Each Date | <u>42</u> | <u>179,879.56</u> | 4,282.85 | |
| TOTAL | 57 | 1,146,567.14 | | |

B. Regression equation: Y = No. of Increments

X = No. of Days in Period

$$\hat{Y} = 0.88 X - 124.38; r = 0.88$$

C. Testing of Slope ($\beta = \beta_0 = 1$)

1) Standard Error of Regression Coefficient

$$S_b = \sqrt{\frac{S^2_{y.x}}{\sum X^2}} = \sqrt{\frac{5,054.93}{1,154,798.91}} = 0.066$$

2) t-test (df = 56)

$$t_s = \frac{b-1}{S_b} = \frac{0.88-1}{0.066} = -1.80 \text{ n.s. (P>.05)}$$

3) 95% Confidence Limits on Regression Coefficient

$$t_{.05} [56] S_b = 2.003 (.066) = 0.13$$

$$0.88 + 0.13 = 1.01$$

$$0.88 - 0.13 = 0.75$$

Figure 14. Average and range (as in Figure 12) of the number of increments in all T and TI clams from the disturbance of 16 October 1979 to the shell margin (data from Table 11). Regression analysis was based on 58 clams collected from 5 April 1980 to 27 June 1981 (Table 12). Solid line: regression; Dashed lines: $\pm 95\%$ confidence limits on regression coefficient (see Table 12).

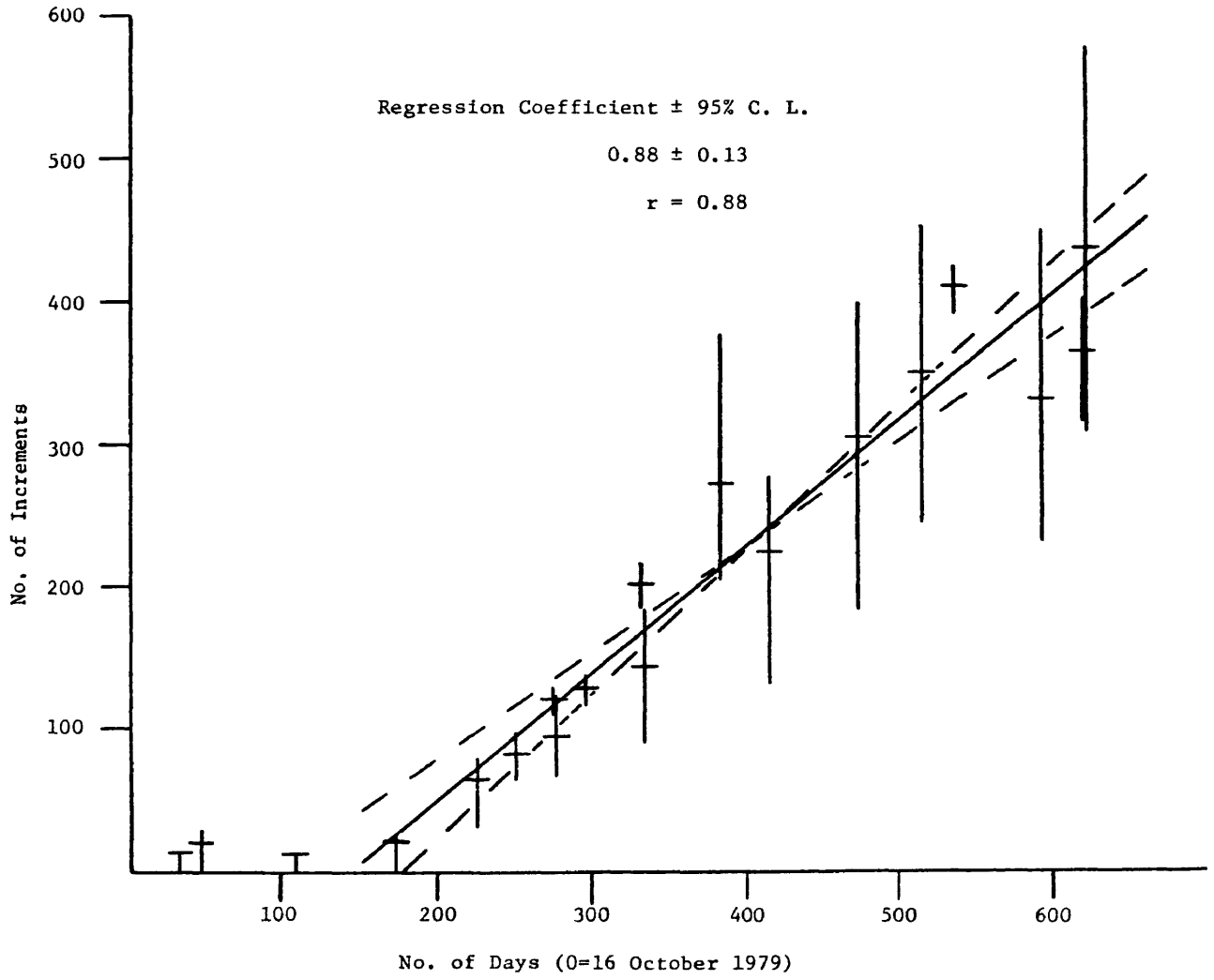

$P < .001$, $r = 0.88$). The regression coefficient (0.88) was also not probability than the coefficient of the TI clams in summer 1980 (Table 10).

Counts from clams collected between 16 October 1979 and 27 February 1980 were excluded from the ANOVA in Table 12. It is believed that disturbance from the transplantation, difference in salinity between the Eastern Shore and the York River, and low winter water temperatures combined to inhibit shell growth by clams in the group during fall and winter of 1979-1980. Clams collected between 5 April 1980 and 27 June 1981, though, tended to form one prismatic increment each day during this 14-month period (Table 12 and Figure 14). However, no T or TI clam analyzed had an exact 1:1 correspondence between increments and days for the period of shell growth in which counts were made, from 16 October 1979 to each date of collection (Table 11). Consequently, cessations of growth by each clam must have occurred at one or more times during the period of growth analyzed.

The observation that T and TI clams tended to form one increment each solar day from 5 April 1980 to 27 June 1981 obscured the fact that 13 of 27 clams collected on or after 4 December 1980 had distinct winter growth cessations in the light band at the shell margin (as in Figure 11D). Growth cessations of varying durations in clams collected on or after 4 December 1980 should have reduced the regression coefficient and increased the deviation from linearity in an ANOVA based on counts from these clams compared with one based on counts of clams collected prior to 4 December 1980. However, results from such ANOVA's (Tables 13 and 14; Figure 15) indicated that there were no significant differences between the two regression coefficients ($F_s = 0.50$, $P > .25$).

Table 13. Analysis of Variance (Regression) of Number of Increments on the Number of Days in the Period in T and TI clams collected prior to 4 December 1980 (t=6 to t=10; n=31) and Testing of the Regression Coefficient ($\beta = \beta_0 = 1$) with 95% Confidence Limits on b. Data from Table 11.

A. ANOVA Table

| Source of Variation | df | SS | MS | F |
|-----------------------------|-----------|------------------|------------|-----------------|
| Among Sampling Dates | 8 | 159,736.96 | 19,967.12 | 15.10***P<.001 |
| Linear Regression | 1 | 144,026.94 | 144,026.94 | 64.17***P<.001 |
| Deviations from Regression | | 15,710.03 | 2,244.29 | 1.69 n.s. P>.10 |
| Within Clams From Each Date | <u>22</u> | <u>29,096.87</u> | 1,322.58 | |
| TOTAL | 30 | 188,833.83 | | |

B. Regression equation: Y = No. of Increments

X = No. of Days in Period

$$\hat{Y} = 1.14 X - 197.48; r = 0.87$$

C. Testing of Slope ($\beta = \beta_0 = 1$)

1) Standard Error of Regression Coefficient

$$S_b = \sqrt{\frac{S^2_{y.x}}{\sum X^2}} = \sqrt{\frac{2,244.29}{110,584.19}} = 0.14$$

2) t-test (df = 29)

$$t_s = \frac{b-1}{S_b} = \frac{1.14-1}{0.14} = 0.99 \text{ n.s. } P>.20$$

3) 95% Confidence Limits on Regression Coefficient

$$t_{.05} [29] S_b = 2.045 (0.14) = 0.29$$

$$1.14 + 0.29 = 1.43$$

$$1.14 - 0.29 = 0.85$$

Table 14. Analysis of Variance (Regression) of Number of Increments on the Number of Days in the Period in T and TI clams collected on or after 4 December 1980 (t=11 to t=16; n=27). Testing of the Regression Coefficient ($\beta = \beta_0 = 1$) with 95% Confidence Limits on b. Data from Table 11.

A. ANOVA Table

| Source of Variation | df | SS | MS | F |
|-----------------------------|-----------|-------------------|-----------|-----------------|
| Among Sampling Dates | 6 | 119,606.74 | 19,934.46 | 2.64* P<.05 |
| Linear Regression | 1 | 74,993.16 | 74,993.16 | 8.40* P<.05 |
| Deviations from Regression | 5 | 44,613.58 | 8,922.71 | 1.18 n.s. P>.25 |
| Within Clams From Each Date | <u>20</u> | <u>150,782.69</u> | 7,539.13 | |
| TOTAL | 26 | 270,389.43 | | |

B. Regression equation: Y = No. of Increments

X = No. of Days in Period

$$\hat{Y} = 0.74 X - 48.60; r = 0.53$$

C. Testing of Slope ($\beta = \beta_0 = 1$)

1) Standard Error of Regression Coefficient

$$S_b = \sqrt{\frac{S^2_{y.x}}{\sum X^2}} = \sqrt{\frac{8,922.71}{138,089.18}} = 0.25$$

2) t-test (df = 25)

$$t_s = \frac{b-1}{S_b} = \frac{0.74-1}{0.25} = -1.04 \text{ n.s. } P>.20$$

3) 95% Confidence Limits for Regression Coefficient

$$t_{.05} [25] S_b = 2.060 (.25) = 0.52$$

$$0.74 + 0.52 = 1.26$$

$$0.74 - 0.52 = 0.22$$

Figure 15. Average and range (as in Figure 12) of the number of increments in all T and TI clams as in Figure 14. Regression analysis was based on 31 clams collected from the spring through the fall of 1980 (Table 13) and 27 clams collected from the winter of 1980 through the spring of 1981 (Table 14). Solid lines: regressions; Dashed lines: $\pm 95\%$ confidence limits on regression coefficients (see Tables 13 and 14).

Regression Coefficient \pm 95% C. L.

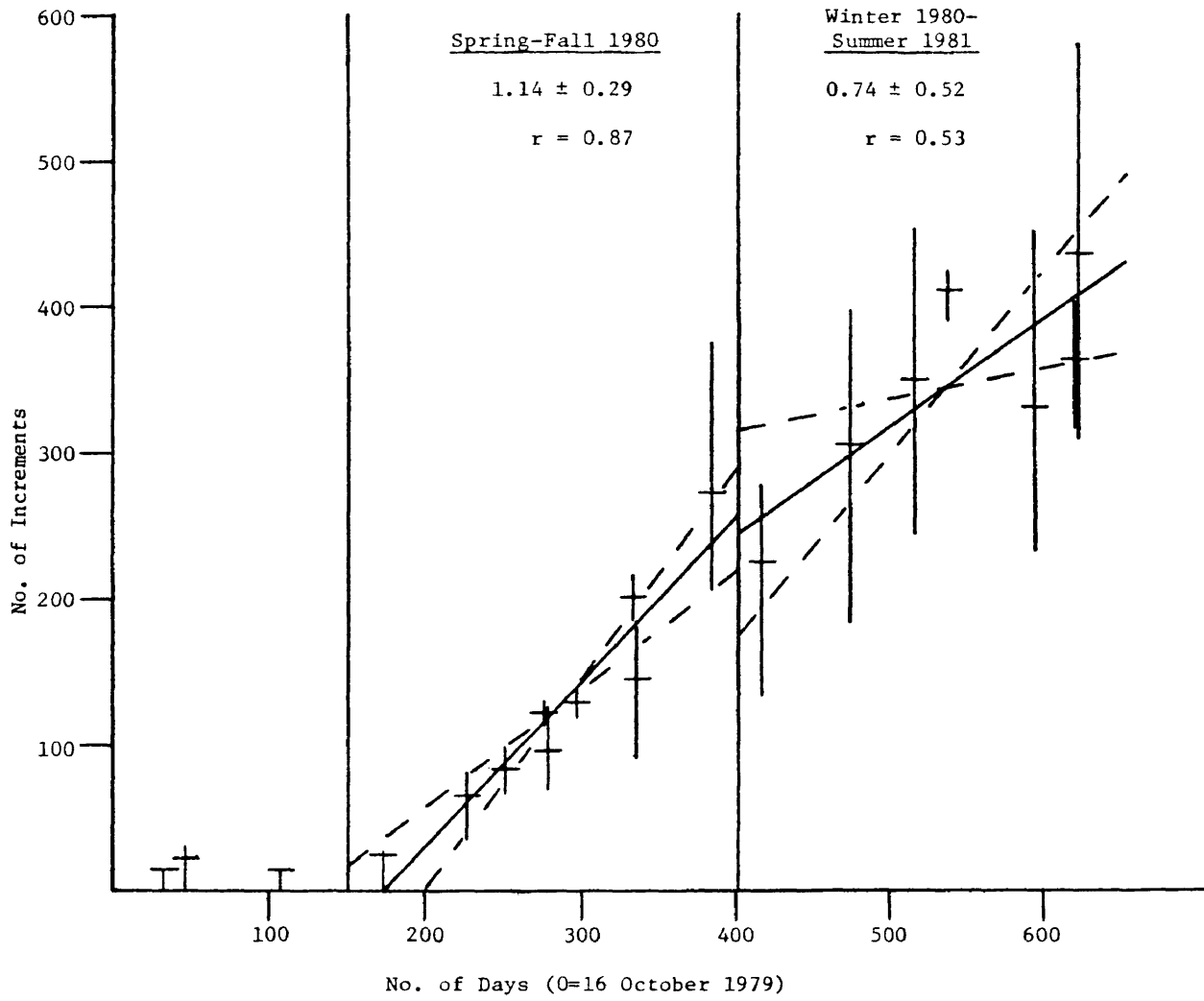

Furthermore, neither regression coefficient was significantly different from 1.00 (a. spring to fall 1980: $t_s=0.99$, $P>.20$ (Table 13); b. winter 1980 to summer 1981: $t_s=-1.04$, $P>.20$ (Table 14)), nor from the regression coefficient based on all the counts ((see Table 12) (a. spring to fall 1980: $F_s=0.49$, $P>.25$; b. winter 1980 to summer 1981: $F_s=0.11$, $P>.50$)). The amount of the variation in counts expressed by a linear relationship was also highly significant in both cases, though at an increased probability level of type II error in the winter 1980 to summer 1981 counts ($F=8.40$, $P<.05$, $r=0.53$) than in the spring to fall 1980 counts ($F=64.17$, $P<.001$, $r=0.87$).

The statistical tests in Tables 13 and 14, however, do not test solely for the effects of growth cessations in the winter of 1980-1981 on reduced regression coefficients or deviations from linearity. Individual variability in numbers of days of growth (increments) anytime during the shell growth period over which counts were made could also have obscured the effects of winter. Individual variability was evident in clams from within almost all single collections by the large range in counts (Table 11; Figures 14 and 15). Furthermore, the average number of increments counted in clams from four collections (TI-2, TI-4, t=10, t=14) was larger than in clams from both collections before and after each of them. Variability in counts was most probably a result of either an earlier resumption of growth after transplantation in some clams than in others, and/or growth cessations of varying durations in winter.

In summary, T and TI clams formed, on the average, one increment each solar day of activity during all periods of monitored shell growth. However, individual variability in absolute numbers of

increments formed over long periods of monitored shell growth (e.g. longer than the four months tested in the TI series) made interpretation of statistical results difficult. This was especially true in light of observed growth cessations in the winter of 1980-1981 in almost half of the clams collected on or after 4 December 1980.

3. Daily increments and known annual increments formed between 1968 and 1972 by clams in lots XI and II

There was considerable variability among the single age-class T and TI clams in the number of increments formed in any but the shortest of defined periods. Clams in experimental lots XI and II, which had a large range in age, each had the same time periods defined in shell microstructure by the series of MDM's. These two characteristics of clams in lots XI and II provided conditions where the effects of increasing age could be observed on the number of daily increments in a series of nearly annual increments. Data were divided into pooled pre-1972 and 1972 sub-sets to observe the effects of tropical storm Agnes on shell growth in 1972 (see Results section II.B.1.c.).

The median percent agreement between numbers of increments and days between annual MDM's decreased with increasing clam age in both the pre-1972 and 1972 data for clams in both lots (Tables 15 and 16; Figures 16 and 17). This decline was consistent in both lots despite the small number of clams in some age classes. The relationship appears to be curvilinear (Figure 16), which is not unexpected. Older clams deposit at least some daily increments in each annual shell increment, but in decreasing numbers each year. On the other hand, younger clams could

Table 15. Percent Agreement Between the Number of Daily Increments and the Number of Days Between Measurement Disturbance Marks, Approximately One Year Apart in Lot XI Clams With Respect to Age From 1969-1972. Each Percent Represents One Clam. Pooling 1969-1971 Data Shows the Decreased Agreement in 1972.

| Year | Age (In Years) At Beginning of Each Interval | | | | | | | | | | |
|-------------------|--|------|------|------|------|------|------|------|-----|--|--|
| | 3 | 4 | 5 | 6 | 7 | 8 | 9 | 10 | 11 | | |
| 1969 ¹ | 99.0 | 89.5 | 61.5 | 68.0 | 62.6 | 54.4 | | | | | |
| | 75.6 | 98.9 | 95.9 | | | | | | | | |
| | 100.0 | 80.1 | | | | | | | | | |
| 1970 ² | 97.2 | 62.8 | 59.2 | 40.1 | 58.4 | | 58.9 | | | | |
| | 93.3 | 73.4 | 75.3 | 69.2 | | | | | | | |
| | | 62.3 | 52.0 | | | | | | | | |
| 1971 ³ | | 82.0 | | | | | | | | | |
| | | 83.6 | 52.4 | 58.6 | 33.9 | 47.4 | | 47.1 | | | |
| | | 55.4 | 60.3 | 64.2 | 60.1 | | | | | | |
| 1972 ⁴ | | 79.4 | 48.6 | 66.1 | | | | | | | |
| | | 69.2 | 68.0 | | | | | | | | |
| | | 45.1 | 42.6 | 19.2 | 25.7 | 16.3 | 16.4 | 10.8 | 7.1 | | |
| | 69.8 | | 30.4 | 19.6 | 20.4 | 15.6 | | | | | |
| | 78.1 | | 51.4 | 28.5 | 20.8 | | | | | | |
| | 66.1 | | 33.3 | 32.9 | | | | | | | |
| | | | 34.5 | | | | | | | | |
| | | | 27.6 | | | | | | | | |
| | | | 28.7 | | | | | | | | |
| | | | 35.8 | | | | | | | | |

Table 15. (continued)

| Year | Age (In Years) At Beginning of Each Interval | | | | | | | | | | |
|-----------|--|-----------|-----------|-----------|-----------|-----------|------|------|-----|--|--|
| | 3 | 4 | 5 | 6 | 7 | 8 | 9 | 10 | 11 | | |
| 1969-1971 | | | | | | | | | | | |
| Median | 95.3 | 79.4 | 60.3 | 65.2 | 59.2 | 50.9 | 58.9 | 47.1 | | | |
| Range | 75.6-100.0 | 55.4-98.9 | 48.6-95.9 | 40.1-69.2 | 33.9-62.6 | 47.4-54.4 | -- | -- | | | |
| N | 6 | 11 | 9 | 6 | 4 | 2 | 1 | 1 | | | |
| 1972 | | | | | | | | | | | |
| Median | 69.8 | 45.1 | 33.9 | 24.0 | 20.8 | 16.0 | 16.4 | 10.8 | 7.1 | | |
| Range | 66.1-78.1 | - | 27.6-51.4 | 19.2-32.9 | 20.4-25.7 | 15.6-16.3 | -- | -- | -- | | |
| N | 3 | 1 | 8 | 4 | 3 | 2 | 1 | 1 | 1 | | |

1 1/24/69 to 10/16-21/69; 270 days.

2 10/28/69 to 11/17/70; 385 days.

3 11/20/70 to 10/5/71; 319 days.

4 Age 3 clams: 10/13/71 to 10/11, 12/72; 364 days. All other ages: 10/7, 8/71 to 10/11, 12/72; 369 days.

Table 16. Percent Agreement Between the Number of Daily Increments and the Number of Days Between Measurement Disturbance Marks One Year Apart in Lot II Clams With Respect to Age. Each Percent Represents One Clam. Pooling 1968-1971 Data Shows the Decreased Agreement in 1972.

| Year | Age (In Years) At Beginning of Each Interval | | | | | | | |
|-------------------|--|------|------|------|------|------|------|------|
| | 2 | 3 | 4 | 5 | 6 | 7 | 8 | |
| 1968 ¹ | { | 64.2 | | | | | | |
| | | 41.5 | | | | | | |
| 1969 ² | { | | | 63.5 | | | | |
| | | | | 69.1 | | | | |
| | | | | 75.9 | | | | |
| 1970 ³ | { | 96.5 | | | 52.7 | 66.1 | | |
| | | | | | 57.1 | 63.0 | | |
| 1971 ⁴ | { | 80.3 | 81.3 | | 75.5 | 43.1 | 53.7 | |
| | | | 78.2 | | | 58.0 | 56.4 | |
| 1972 ⁵ | { | 63.2 | | 51.4 | 51.0 | 43.8 | 27.9 | 9.9 |
| | | 41.9 | | 48.5 | | | 18.2 | 25.7 |
| | | 64.5 | | | | | 6.2 | |
| | | 44.6 | | | | | 14.5 | |
| | | 48.2 | | | | | 19.1 | |
| | | 32.7 | | | | 32.0 | | |

Table 16. (continued)

| Year | Age (In Years) At Beginning of Each Interval | | | | | | | |
|-----------|--|-----------|-----------|-----------|-----------|-----------|----------|--|
| | 2 | 3 | 4 | 5 | 6 | 7 | 8 | |
| 1968-1971 | | | | | | | | |
| Median | 80.3 | 78.2 | 69.1 | 57.1 | 60.5 | 55.0 | | |
| Range | -- | 41.5-96.5 | 63.5-75.9 | 52.7-75.5 | 43.1-66.1 | 53.7-56.4 | | |
| N | 1 | 5 | 3 | 3 | 4 | 2 | | |
| 1972 | | | | | | | | |
| Median | | 46.4 | 50.0 | 51.0 | 43.8 | 18.6 | 17.8 | |
| Range | | 32.7-64.5 | 48.5-51.4 | -- | -- | 6.2-32.0 | 9.9-25.7 | |
| N | | 6 | 2 | 1 | 1 | 6 | 2 | |
| 1 | 9/13/67 to 10/15/68; 397 days. | | | | | | | |
| 2 | 10/15/68 to 11/1/69; 382 days. | | | | | | | |
| 3 | 11/3/69 to 10/12/70; 343 days. | | | | | | | |
| 4 | 10/19/70 to 10/18/71; 364 days. | | | | | | | |
| 5 | 10/26/71 to 9/18-20/72; 329 days. | | | | | | | |

Figure 16. Distribution of the percent agreements between the numbers of daily increments and days between measurements for each age of lot XI clams measured approximately one year apart between 1969 and 1972. Data appears as solid (1969-1971) or dashed (1972) horizontal bars (for $n=1$), horizontal and vertical bars (for $n=2$ to $n=4$), or stem and whisker diagrams (for $n>4$; data from Table 15).

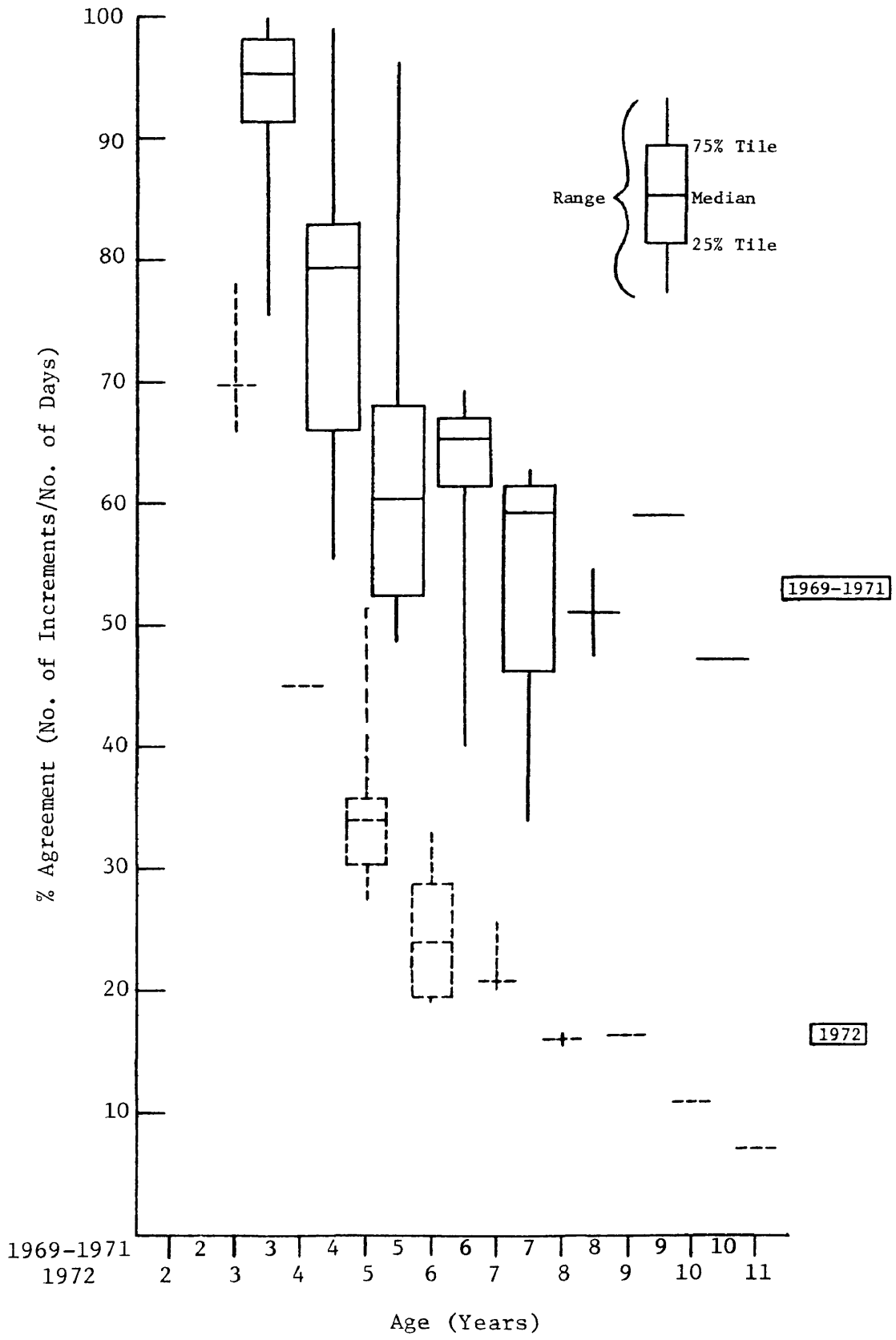
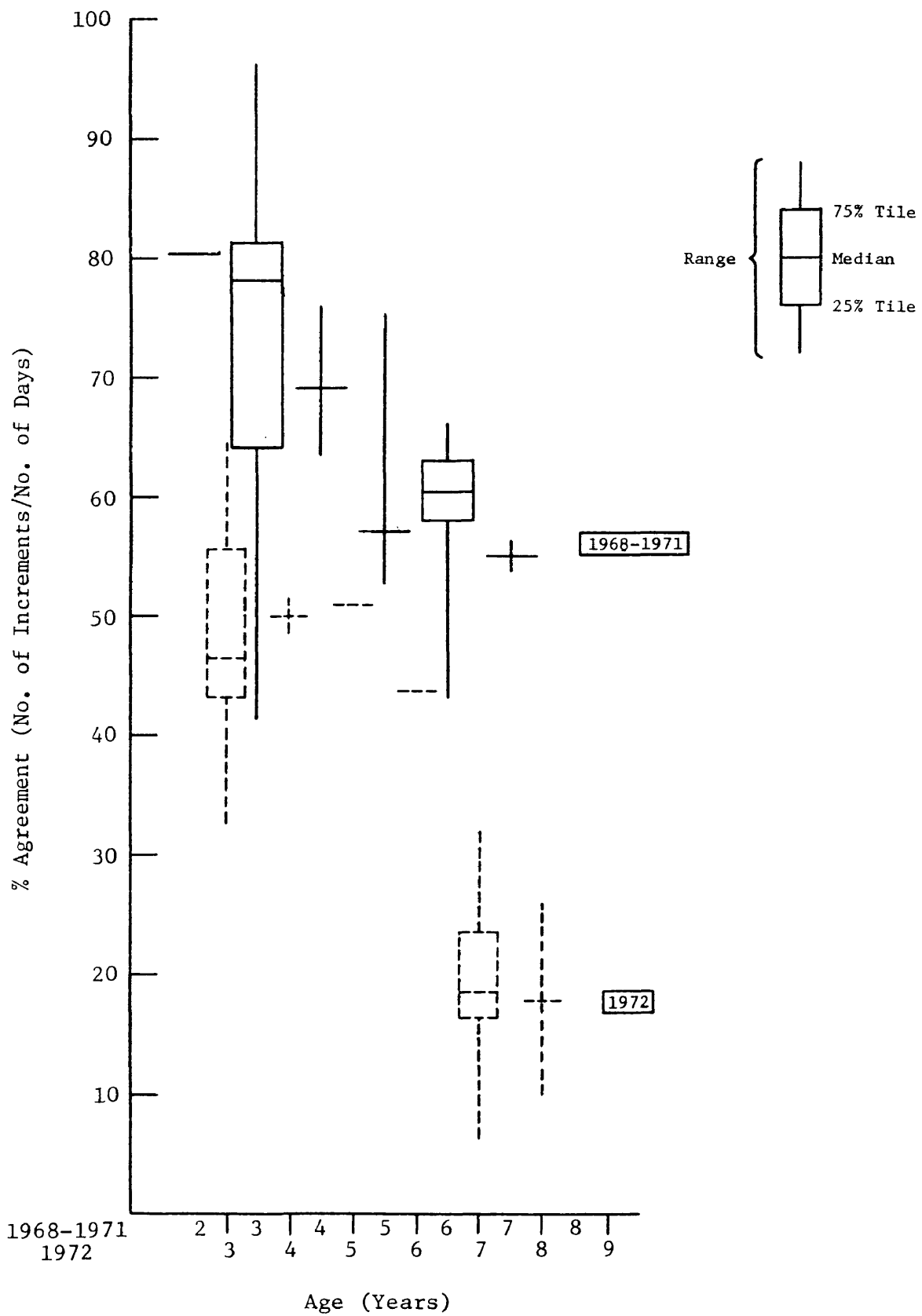

Figure 17. Distribution of the percent agreements between the numbers of daily increments and days between measurements for each age of lot II clams measured approximately one year apart. Data are presented as in Figure 16 and are taken from Table 16.



not form more than one daily increment per solar day, which would yield a maximum of 100% agreement. Consequently, clams deposit shell during fewer number of days each year with increasing age. This conclusion is in agreement with the hypothesis presented previously; that the growing season of clams becomes increasingly limited to spring and early summer with age.

B. Daily increments and middle homogenous layer bands

Counts and average width determinations of daily increments associated with light and dark bands in the middle homogenous layer of experimental clams (lots XI and II, and the T and TI series) revealed that average growth rates were slower in summer (dark bands) than in fall or spring (light bands). However, there was considerable individual variability in the number of daily increments (or days of growth) associated with any contemporary band (i.e. the dark band formed during the summer of 1971 by a group of clams) in all groups of clams analyzed. This variability appeared to be independent of age and location, since clams of the same age and growing at the same location had large differences in the number of daily increments in any single band. Despite this variability in the apparent number of days of growth among clams in a particular season, the effects of tropical storm Agnes on the average width and number of increments formed in summer 1972 were apparent in the experimental clams in lots XI and II. Furthermore, daily increment counts in T and TI clams were useful in relating the time of dark band formation with York River water temperatures and in describing growth before and after winter.

1. Experimental lots XI and II

a. Average daily increment width

The average daily increment associated with a dark band was usually narrower than one associated with a light band formed during the same year. The median average widths of daily increments associated with dark bands formed in 1969, 1970, and 1971 by lot XI clams were 33, 24, and 21 $\mu\text{m}/\text{increment}$, respectively (Figure 18). For lot II clams in 1971, the median average increment width in the dark band was 26 $\mu\text{m}/\text{increment}$ (Figure 18). Light bands formed in spring and fall of each of these years had wider increments associated with them than with dark bands. The median average increment width ($\mu\text{m}/\text{increment}$) in each of the light bands formed between 1969 and 1971 by clams in the two lots were: 1) Lot XI: 1969 - 44 and 48, 1970 - 40 and 31, and 1971 - 31 (spring only); 2) Lot II: 1971 - 32 and 39. Individual clams in certain annual increments had average daily increment widths in the dark band which were greater than in either or both light bands. This occurred only 17 times in the 181 bands in which increments were counted, or with a frequency of 9%. Consequently, average daily growth rates in summer were almost always less than those in spring or fall of the same year.

b. Number of increments per band and winter growth cessations

The median number of daily increments in each of the spring light bands and summer dark bands formed between 1969 and 1971 was approximately 100 (Figure 19). However, the range of counts from contemporary bands among clams of the same group was quite large in all

Figure 18. Distribution of average daily increment widths ($\mu\text{m}/\text{inc}$) in each band in the experimental clams from lots XI and II formed from 1969 to 1972. Daily increments were counted and growth bands measured only between MDM's formed one year apart. Counts and measurements of annual increments were made in the number of clams shown in parentheses over each spring light band or summer dark band. The number of these with a fall light band also appears in parentheses for each annual increment. Range in age (years) of clams analyzed for each annual increment is shown.

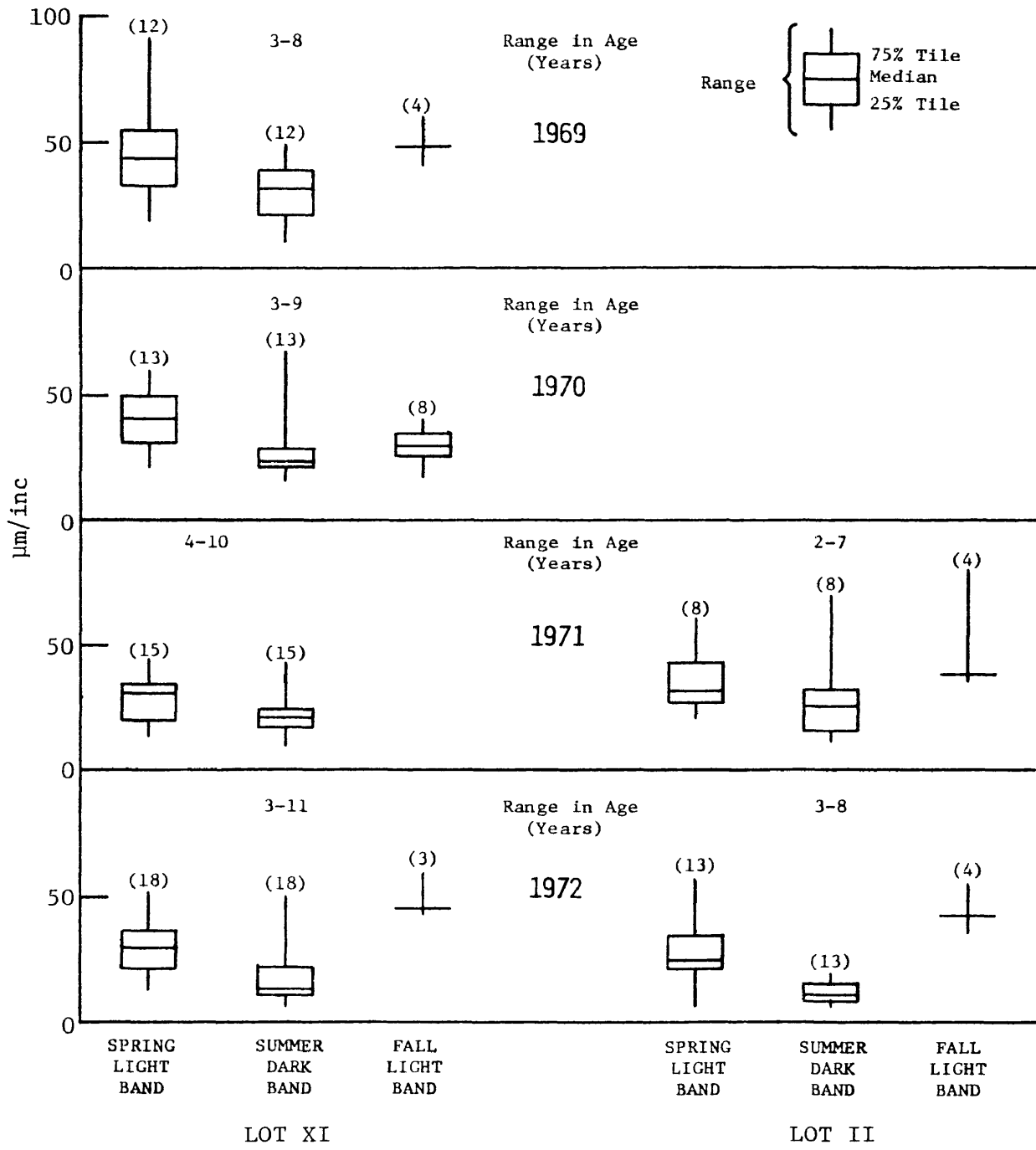
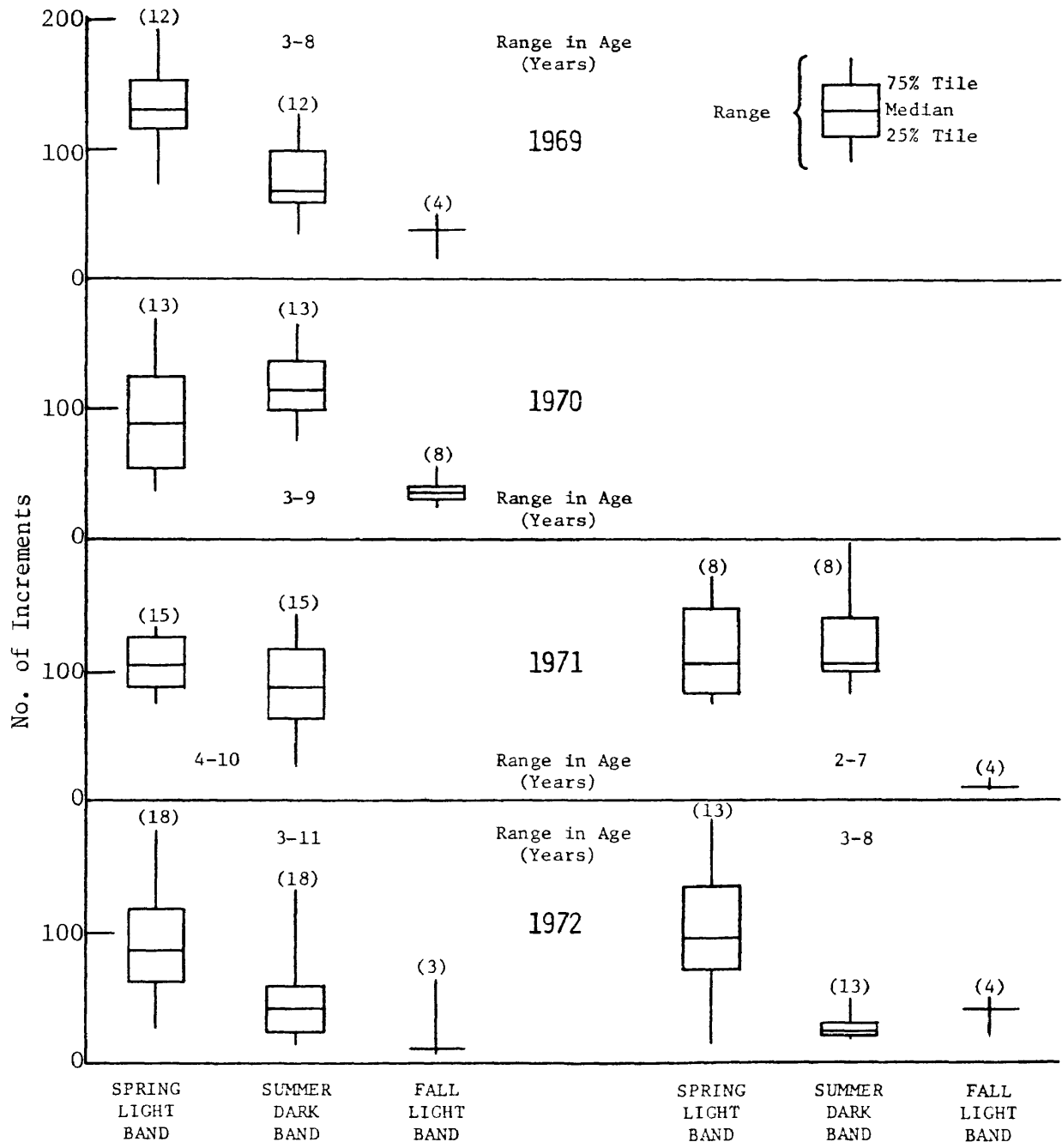

Figure 19. Distribution of the number of daily increments in each growth band in experimental clams from lots XI and II formed 1969 to 1972. Number of clams analyzed and range in age of clams are shown as in Figure 18.



LOT XI

LOT II

bands from all years. This was most probably due to individual variation in seasonal growth as well as the range in age of the clams in each sample. As discussed previously, the percent agreement between the number of daily increments and days in annual shell increments decreased with increasing age.

The small number of increments in fall light bands formed between 1969 and 1972 was an artifact of the annual measurements each fall. Since measurements were counted only between two MDM's formed one year apart, the number of days of fall growth was small. However, some increments included in the spring light band of the next annual increment may have been formed the previous fall. This would have occurred if the clam resumed growth in fall after being replanted and prior to winter. If this had occurred, the spring light band of the following annual increment would be expected to have a distinct winter growth cessation within it.

Distinct winter growth cessations, however, were not common in annual increments formed between 1969 and 1972 in clams from the two lots. Only 37% (29/79) of the spring light bands analyzed had distinct growth cessations within them which could be attributed to winter. One of these is shown in Figure 6A, and appears as the thick organic line approximately 2 mm to the right (toward the shell margin) of the MDM marked 18 October 1970, and is labelled 17 February 1971. This date (17 February 1971) was obtained by counting daily increments back from the MDM of 17 October 1971 and is the date on which this clam resumed growth in late winter. Clams with distinct winter growth cessations tended to be mature rather than old clams, which supports the results presented

previously on age and its effects on fall growth (see Tables 6 and 7; Figure 10).

The lack of visible, distinct winter growth cessations in the remaining clams of both lots, though, may be due more to the fall measurement disturbance than the actual lack of a growth cessation in winter. For a representation of a winter growth cessation to be distinct, shell growth must have resumed in fall after the clam was replanted. If growth did not resume until the following spring due to disturbance and/or decreasing water temperatures in late fall, then the MDM and the winter growth cessation would be one and the same mark in microstructure.

c. Effects of tropical storm Agnes

The median percent agreement between the number of daily increments and days in annual shell increments was lower for each age class in 1972 than in the three or four previous years for clams in lots XI and II (see Tables 15 and 16; Figures 16 and 17). This was most probably due to the effects of storm Agnes on water quality in the lower Bay. Each age class of clams analyzed had a lower percent agreement in 1972, but clams older than 4 (in lot XI) and 6 (in lot II) years of age appeared to have had a larger decrease than younger clams. However, the data are too few to make more definitive conclusions.

Analyses of daily increments (average width and counts) associated with dark and light bands in 1972 further detail the effects of storm Agnes on shell growth by hard clams. The dark band formed in summer 1972 had narrower and fewer daily increments than those formed in

the previous three years (Figures 18 and 19). The median average daily increment widths in the dark bands formed in 1972 by clams in lots XI and II were 14 and 12 $\mu\text{m}/\text{inc}$, respectively (Figure 18). This was a decrease of between 7 and 21 $\mu\text{m}/\text{inc}$ from the median average increment widths of dark bands formed the previous three years by clams in the two lots. The median numbers of increments in the dark bands of 1972 were 42 and 23 for clams in the two lots (Figure 19), or approximately one-half and one-quarter, respectively, of the number of increments in the three previous dark bands. It is significant, however, that the light band formed in the spring of 1972 was unaffected in both median average width and number of daily increments (Figure 18 and 19). This was due to the arrival of storm Agnes to the watersheds of Chesapeake Bay tributaries in late June 1972 (Hargis 1974; Haven et al. 1976), or at approximately the time of dark band initiation by clams in Virginia, as discussed previously. Consequently, shell growth in spring 1972 was unaffected. However, the effects of storm Agnes (e.g. low salinities and high turbidities for as long as three months (Hargis 1974; Haven et al. 1976)) reduced both the growth rate and the number of days of growth during the summer of 1972 for experimental clams in the James (lot XI) and York (lot II) rivers.

2. T and TI clams

a. Average increment width

Average width of daily increments was greater in light than dark bands in the experimental clams discussed previously, as well as the T and TI clams to be discussed. The light formed from fall

1980 to spring 1981 had the largest median average increment width (35.6 $\mu\text{m}/\text{inc}$) of the four bands analyzed (Table 17 and Figure 20). The two dark bands formed in the summers of 1980 and 1981 had median average increment widths approximately 10 $\mu\text{m}/\text{inc}$ less, at 24.6 and 24.3 $\mu\text{m}/\text{inc}$, respectively.

Increments associated with light bands, however, were not always wider than those associated with dark bands. The light band formed in fall 1979 to spring 1980 had the smallest median average increment width of the four bands analyzed in the T and TI clams (21.2 $\mu\text{m}/\text{inc}$). This was most likely an artifact of transplantation the previous fall. However, there were also four clams which had wider average increments in the dark band formed during summer 1980 than in the light band following it (Table 17 and Figure 20; collections of 4 December 1980 and 4 April 1981). In all four instances, the color of the band was as indicated, but was apparently independent of average increment width. This band color-increment width relationship was not the most common. The fall 1980 to spring 1981 light band usually had a larger average increment width than the summer 1980 dark band in each individual.

b. Number of increments per band

The pattern created by the plot of counts of daily increments in each light and dark band in the T and TI clams (Figure 21; data in Table 18) was very similar to that created by the plot of the band width measurements from the same collections (Figure 12). During periods when a particular band was at the shell margin (averages connected by lines

Table 17. Average and Range of Average Increment Width ($\mu\text{m}/\text{inc}$) in Each Growth Band in all T and TI clams from the Disturbance Mark of 16 October 1979 to the Shell Margin.

| Date | Sampling Time | Fall 1979-Spring 1980 Light Band | | Summer 1980 Dark Band | | Fall 1980-Spring 1981 Light Band | | Summer 1981 Dark Band | |
|----------|---------------|----------------------------------|-----------------------|-----------------------|-----------|----------------------------------|-----------|-----------------------|-----------|
| | | Average ¹ | Range | Average ¹ | Range | Average ¹ | Range | Average ¹ | Range |
| 10/16/79 | 0 | 0.0 | - | | | | | | |
| 10/25/79 | 1 | 0.0 | - | | | | | | |
| 11/ 4/79 | 2 | 0.0 | - | | | | | | |
| 11/17/79 | 3 | 8.4 | 0.0- 9.1 | | | | | | |
| 12/ 4/79 | 4 | 7.3 | 0.0- 7.6 | | | | | | |
| 2/ 2/80 | 5 | 6.5 | - | | | | | | |
| 4/ 5/80 | 6 | 10.1 | 0.0-11.7 | | | | | | |
| 5/29/80 | 7 | 14.7 | 10.1-20.5 | | | | | | |
| 6/22/80 | | 17.6 | 15.5-20.5 | | | | | | |
| 7/18/80 | 8, TI-1 | 23.1 | 13.3-26.0 | 20.8 | 9.5-37.3 | | | | |
| 8/ 8/80 | 8, TI-2 | 23.2 | 15.4-28.0 | 25.8 | 21.9-30.8 | | | | |
| 9/13/80 | 9, TI-3 | 20.7 | 14.1-26.7 | 27.0 | 17.4-46.9 | 46.7 | 26.7-66.7 | | |
| 11/ 1/80 | 10, TI-4 | 24.4 | 20.4-28.0 | 26.1 | 17.4-36.7 | 46.8 | 37.7-56.3 | | |
| 12/ 4/80 | 11 | 18.6 | 11.7-22.3 | 26.8 | 12.7-38.9 | 26.0 | 9.2-40.0 | | |
| 1/31/81 | 12 | 21.1 | 16.5-30.5 | 24.7 | 16.8-29.5 | 30.6 | 21.7-37.2 | | |
| 3/14/81 | 13 | 24.6 | 22.4-27.4 | 25.8 | 16.4-36.2 | 34.5 | 22.4-45.2 | | |
| 4/ 4/81 | 14 | 22.8 | 20.5-26.5 | 23.4 | 18.2-27.7 | 26.4 | 17.1-36.5 | | |
| 5/31/81 | 15 | 21.0 | 18.8-23.1 | 19.2 | 8.7-26.2 | 34.7 | 26.6-42.9 | | |
| 6/27/81 | 16, TI-5 | 21.4 | 16.2-31.9 | 24.2 | 10.4-40.0 | 37.3 | 32.8-42.2 | 22.2 | 12.3-27.8 |
| TOTAL | - | 19.1 | 7.6-31.9 ¹ | 24.4 | 8.7-46.9 | 34.9 | 9.2-66.7 | 22.2 | 12.3-27.8 |

¹ Average and range of those clams with recognizable increments.

Figure 20. Distribution of average daily increment widths ($\mu\text{m}/\text{inc}$) in each growth band from the disturbance of 16 October 1979 to the shell margin in all T and TI clams with recognizable increments (data from Table 17).

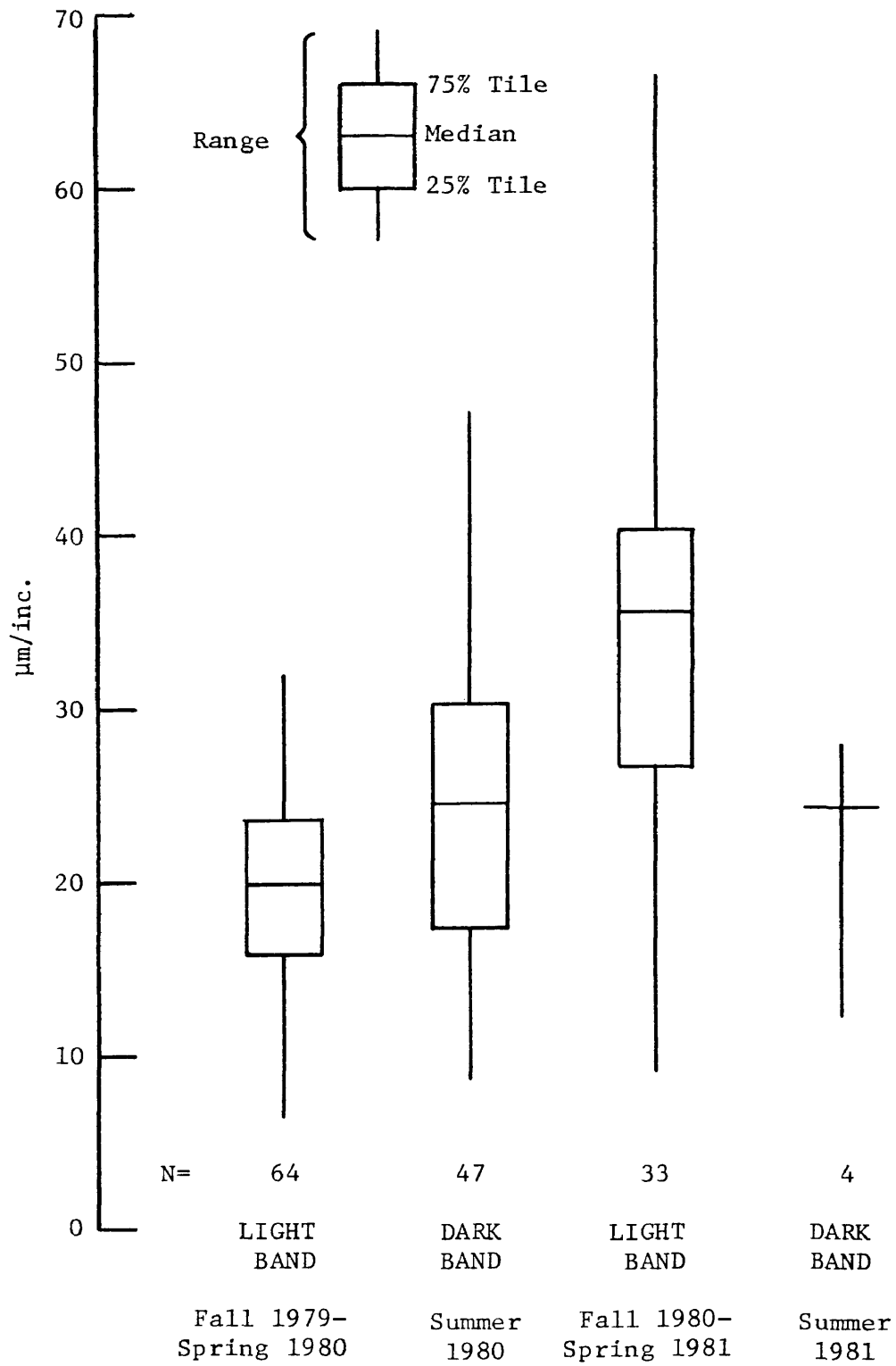
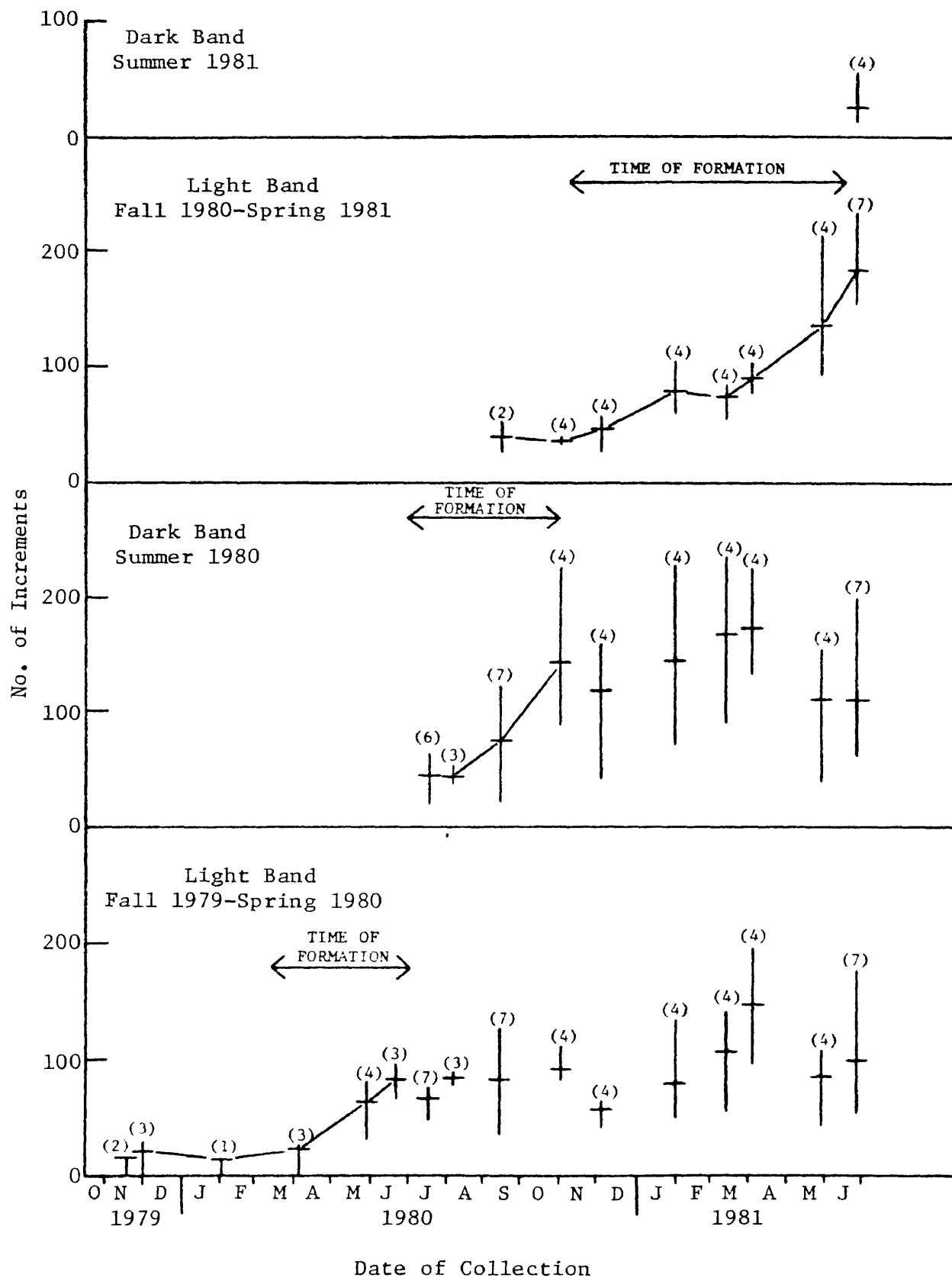

Table 18. Number of Daily Increments (Average and Range) in all T and TI-Clams in Each Growth Band from the Disturbance Mark of 16 October 1979 to the Shell Margin. (See Table 11 For Number With Recognizable Increments).

| Date | Sampling Time | Fall 1979-Spring 1980 Light Band | | Summer 1980 Dark Band | | Fall 1980-Spring 1981 Light Band | | Summer 1981 Dark Band | |
|---------------|---------------|----------------------------------|---------|------------------------|---------|----------------------------------|---------|-----------------------|--------|
| | | Average ¹ | Range | Average ¹ | Range | Average ¹ | Range | Average ¹ | Range |
| 10/16/79 | 0 | 0 | - | | | | | | |
| 10/25/79 | 1 | 0 | - | | | | | | |
| 11/ 4/79 | 2 | 0 | -- | | | | | | |
| 11/17/79 | 3 | 14 | 0- 14 | | | | | | |
| 12/ 4/79 | 4 | 21 | 0- 29 | | | | | | |
| 2/ 2/80 | 5 | 12 | 0- 12 | | | | | | |
| 4/ 5/80 | 6 | 22 | 0- 26 | | | | | | |
| 5/29/80 | 7 | 64 | 32- 79 | | | | | | |
| 6/22/80 | TI-1 | 83 | 67- 97 | | | | | | |
| 7/18/80 | 8, TI-2 | 68 | 47- 77 | 45 | 21- 63 | | | | |
| 8/ 8/80 | TI-3 | 84 | 79- 89 | 45 | 39- 53 | | | | |
| 9/13/80 | 9, TI-4 | 83 | 35-126 | 74 | 26-122 | 39 | 27- 51 | | |
| 11/ 1/80 | 10 | 92 | 83-111 | 143 | 88-226 | 36 | 35- 39 | | |
| 12/ 4/80 | 11 | 58 | 41- 64 | 119 | 43-159 | 47 | 27- 57 | | |
| 1/31/81 | 12 | 80 | 49-134 | 145 | 75-228 | 80 | 60-103 | | |
| 3/14/81 | 13 | 107 | 55-141 | 169 | 90-237 | 75 | 65- 84 | | |
| 4/ 4/81 | 14 | 148 | 113-196 | 173 | 133-226 | 91 | 79-103 | | |
| 5/31/81 | 15 | 86 | 42-107 | 111 | 40-156 | 135 | 93-213 | | |
| 6/27/81 | 16, TI-5 | 99 | 57-175 | 111 | 62-197 | 183 | 152-232 | 26 | 13- 54 |
| GRAND AVERAGE | ±95% CL | 92.9 ± 11.4 (n=41) | | 136.0 ± 20.4 (n=31) | | 180 ± 32.1 (n=4) | | | |

¹Average of those clams with recognizable increments.

Figure 21. Average and range (as in Figure 12) of the number of daily increments in each growth band in all T and TI clams with recognizable increments from the disturbance of 16 October 1979 to the shell margin (data from Table 18). Number of clams represented by each bar is in parentheses. Connected and unconnected averages as in Figure 12.



in Figures 12 and 21), there was an increase in both the average number of increments and the average width of the three bands analyzed. There was also a similar degree of variation among clams from any one collection in the number of increments counted in any particular band (Figure 21) as there was in the band width measurements (Figure 12).

The light band formed in fall 1979 to spring 1980 had approximately one-half the number of increments as the light band formed in fall 1980 to spring 1981 (Table 18 and Figure 21). All clams collected on or after 8 August 1980 ($n=41$) had completed the fall 1979 to spring 1980 light band (Table 8 and Figure 12). The average ($\pm 95\%$ confidence limits) number of increments in this band in these 41 clams was 92.9 (± 11.4 ; Table 18). Consequently, on the average, this light band represented approximately 3 months of actual growth and activity in the 9 month period from October 1979 to July 1980, or when this band was being formed. Furthermore, it appears that T and TI clams stopped growing for approximately 6 months during this period. The light band formed from fall 1980 to spring 1981 was completed by only four clams collected on 27 June 1981 which had a dark band at the shell margin (Table 8 and Figure 12). The average ($\pm 95\%$ confidence limits) number of increments in this band in these four clams was 180 (± 32.1 ; Table 18), or approximately twice that of the light band formed the previous year. This three month (90 days) difference in the number of days of growth represented by the two bands may have been due to transplantation of the clams to lower salinity York River waters in the fall of 1979. Lower water temperatures in the winter of 1979-1980 do not appear to be the cause of this growth differential, since there was little difference in both the

length of time below 10°C or the lowest temperature recorded during the two winters (see Figure 22).

The average number of daily increments in one annual shell increment (one light and one dark band) in the T and TI clams was less than 365, the number of days in one year. The average ($\pm 95\%$ confidence interval) number of daily increments in the dark band of the summer of 1980 in the 31 clams which had completed it (those collected on or after 1 November 1980; Table 8 and Figure 12) was 136 (± 20.4 ; Table 18). The best estimate of the average number of daily increments in an annual increment was obtained by adding the averages in the summer dark band (136) and the fall 1980 to spring 1981 light band (180). This yielded 316 daily increments in an annual increment, or 87% of a full year. The lack of complete representation of a full year's growth was not unexpected since the 1:1 relationship between increments and days does not appear to hold over long periods of monitored shell growth (see Results section II.A.2.)

c. Dark band formation and water temperature

Dark band formation in the summer of 1980 occurred when water temperatures were greater than 25°C. This temperature (25°C) is the upper limit of the optimum range for shell growth by hard clams (Ansell 1968). At temperatures above 25°C, growth rates drop below 50% of maximum (Ansell 1968). York River water temperatures remained at or above 25°C from 22 June to 26 September 1980 (Figure 22). This was approximately the same as the period of dark band formation by the T and TI clams (Figures 12 and 21). Consequently, there may be a link between

Figure 22. Daily noon water temperatures at VIMS pier (at a depth of 1 m) from October 1979 to June 1981. Dates of temperature maxima in the summer of 1980 are shown. Water temperatures were generally above 25°C from late June through September 1980 (broken line).

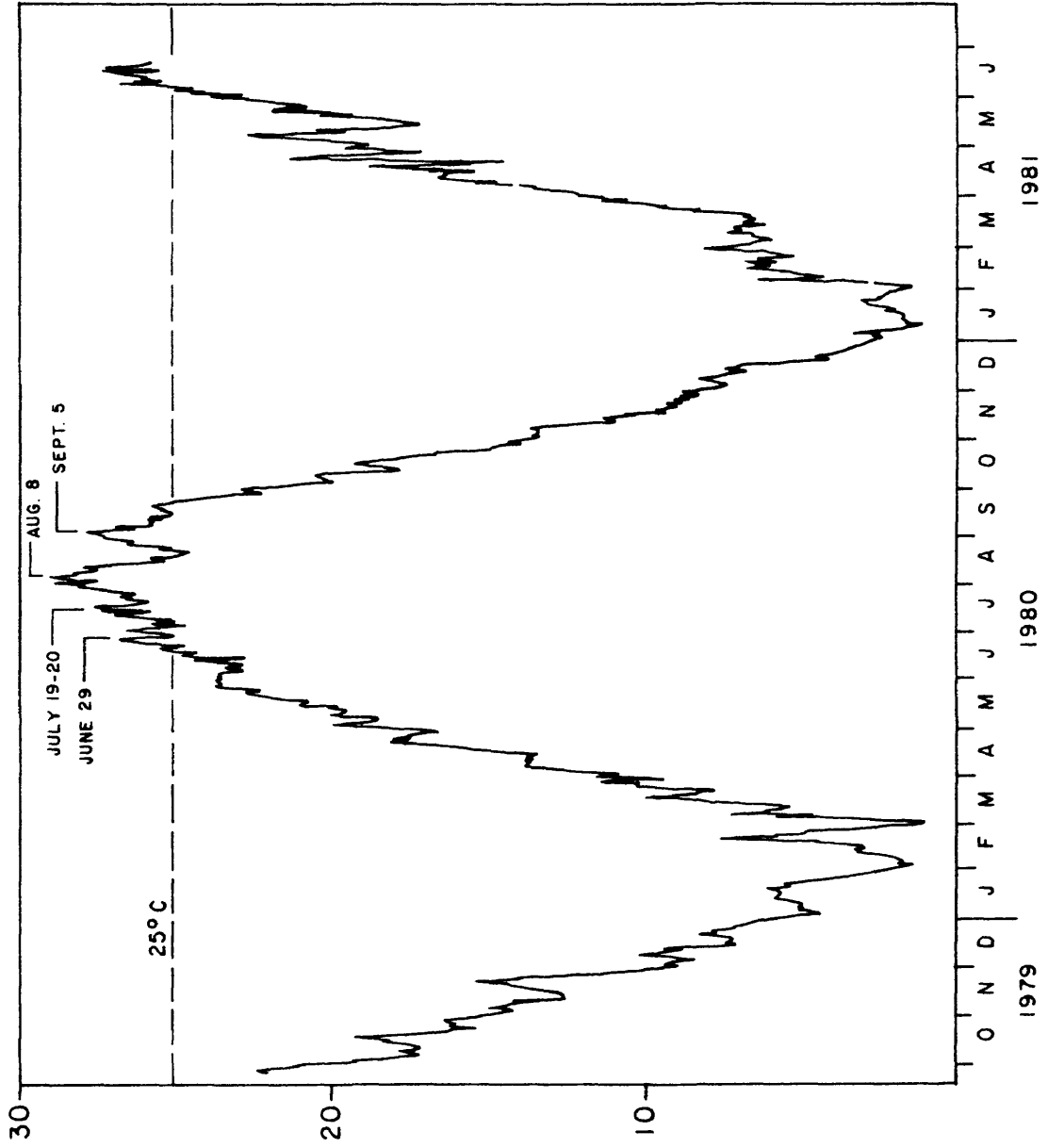

the formation of dark bands and depressed growth rates caused by elevated water temperatures. This observation is supported by the fact that daily increment widths tended to be narrower in dark bands than in light bands (Figures 18 and 20).

A similar relationship between water temperatures greater than 25°C and dark band initiation in 1980 by T and TI clams was observed in early summer 1981. York River water temperatures rose above 25°C on 14 June 1981, or approximately one week earlier than in 1980 (Figure 22). Dark bands were observed at the shell margin in 4 of 7 clams collected on 27 June 1981, while dark bands were not observed at the shell margin until the July collection in 1980 (Table 8 and Figure 12). The earlier rise in water temperatures above 25°C was reflected by the earlier formation of dark bands by the T and TI clams in 1981 than in 1980.

The effects of water temperatures above the optimum range for growth during the summer of 1980 were also seen in the patterns of growth cessations in the dark band. In Figure 22, four water temperature maxima are labelled according to the date(s) on which each was recorded. Eleven of thirty-one clams (35%) which had completed the summer 1980 dark band (Table 8) appeared to represent each of these temperature maxima by either a growth rate reduction or a growth cessation in the dark band. One of these clams is shown in Figure 23. Kennish and Olsson (1975) also found that patterns of heated effluent discharge from a nuclear power plant were represented by growth cessations in the microstructure of hard clams. It is not known why only 35% of the T and TI clams recorded each of the temperature maxima in their microstructure. Apparently, there is as large a degree of variability in the sensitivity of clams to elevated temperatures (and

Figure 23. Enlargement of acetate peel from T clam (T26) collected on 1 November 1980 showing four growth cessations or growth rate reductions (gc) in the dark band (db) formed during the summer of 1980. These may correspond to the four temperature maxima shown in Figure 22. Scale bar represents 1 mm and growth is to the right. The other labels are as defined in Figure 11. See Figure 6 for explanation of contrast.

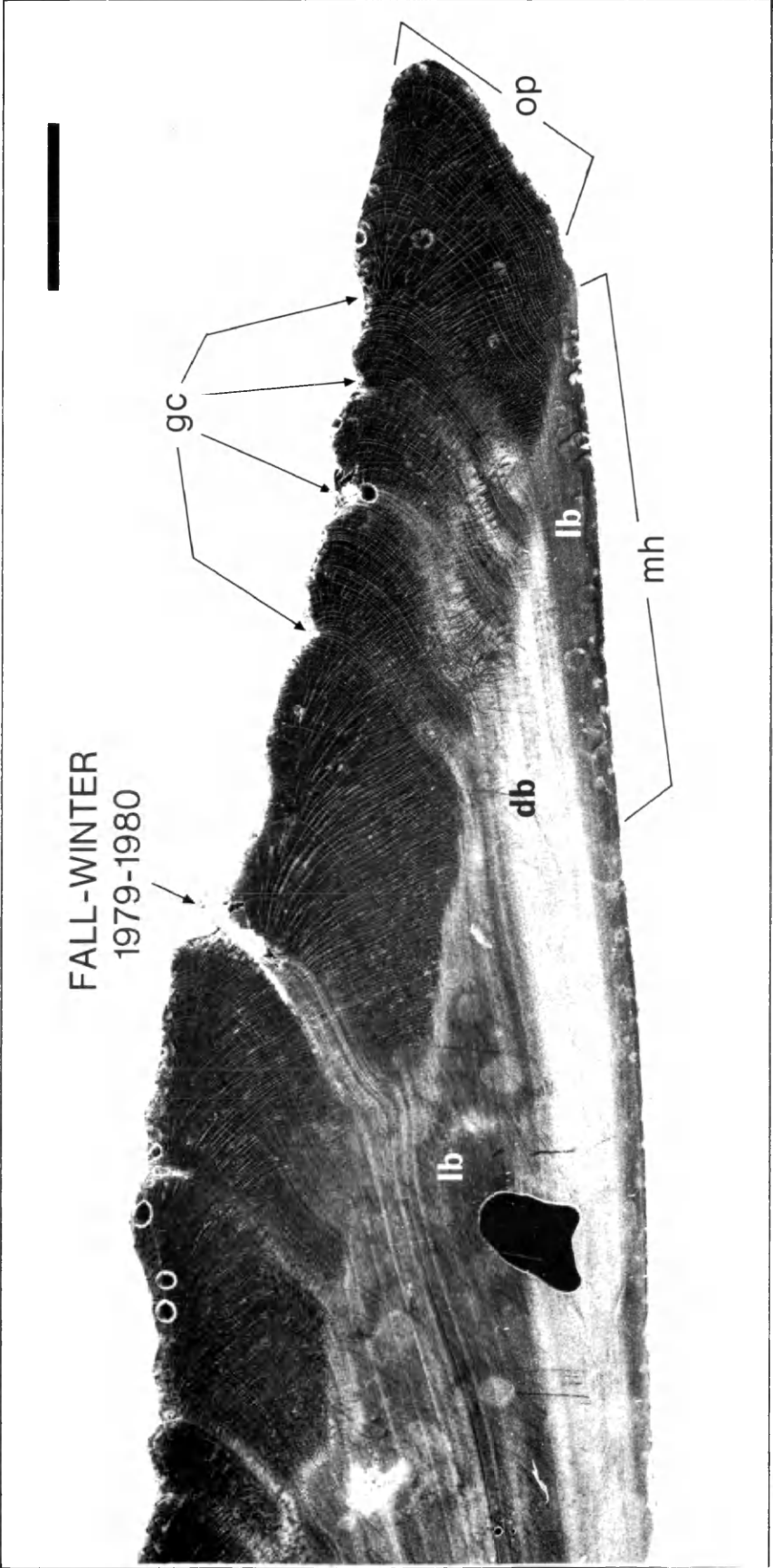

its effects of shell growth) as there was observed in both the band width measurements and daily increment counts discussed previously.

d. Winter growth cessations and water temperature

The winter of 1980-1981 was represented by T and TI clams in three ways, depending on their collection date (Table 19). These were:

- 1) Ten of twelve clams collected from December 1980 through March 1981 had increments of gradually decreasing width at the shell margin, as in Figure 11C. This indicated that the clams were probably inactive at the time of collection (Kennish and Olsson 1975).
- 2) Six of eight clams collected in March-April 1981 had a distinct growth cessation mark near the shell margin (between 1-30 increments from the shell margin). This was the result of a period of inactivity during winter. However, the presence of increments between the margin and the growth cessation mark indicated that growth had resumed prior to collection in either March or April 1981.
- 3) Seven of eleven clams collected in May-June 1981 had a distinct winter growth cessation far (greater than 30 increments) from the shell margin, as in Figure 11D. The average width of all increments deposited after the growth cessation mark was greater in the clams collected in May and June than in those collected in March or April (Table 19). Consequently, growth rates had increased in T and TI clams by late spring compared with early spring 1981.

The observations on growth before, during, and after winter 1980-1981 presented above and in Table 19 describe changes in growth rates as affected by changes in temperature during this period. The optimum temperature range for shell growth in clams is 15-25°C, with maximum growth rates occurring at 20°C (Ansell 1968). Below 10°C,

Table 19. Number of Clams From Each Sampling of T and TI Series During or After Winter 1980-1981 With (a) Increments of Decreasing Thickness at the Shell Edge, (b) A Growth Break Near the Shell Edge (1-30 Increments), (c) A Growth Break Far From the Shell Edge (>30 Increments), or (d) No Growth Break Corresponding to Winter.

| Collection Date | Total | (a) (b) (c) (d) | | | | Data on Growth Increments Formed From Winter Growth Break to Shell Edge | | |
|-----------------|-------|--|------------------------|----------------------------|-----------------|---|---------------|--------------------------|
| | | Decreasing Increment Thickness At Edge | Growth Break Near Edge | Growth Break Far From Edge | No Growth Break | No. of Incs. | μm | $\mu\text{m}/\text{inc}$ |
| 12/ 4/80 | 4 | 4 | 0 | 0 | 0 | - | - | |
| 1/31/81 | 4 | 4 | 0 | 0 | 0 | - | - | |
| 3/14/81 | 4 | 2 | 2 | 0 | 0 | 18 | 216.0 | 12.2 |
| | | | | | | 8 | 75.6 | 9.4 |
| 4/ 4/81 | 4 | 0 | 4 | 0 | 0 | 25 | 475.2 | 18.8 |
| | | | | | | 18 | 237.6 | 13.2 |
| | | | | | | 13 | 259.2 | 19.5 |
| | | | | | | 14 | 151.2 | 11.1 |
| 5/31/81 | | 0 | 0 | 2 | | 62 | 1566.0 | 25.2 |
| | | | | | | 112 | 3132.0 | 28.0 |
| 6/27/81 | | 0 | 0 | 5 | 2 | 124 | 3445.2 | 27.7 |
| | | | | | | 131 | 4503.6 | 34.4 |
| | | | | | | 137 | 5184.0 | 37.8 |
| | | | | | | 130 | 5605.2 | 43.1 |
| | | | | | | 120 | 4482.0 | 37.4 |

growth is very slow while at 6°C, it ceases entirely (Loosanoff 1938). York River water temperatures remained below 14°C for the entire month of November 1980 and dropped below 10°C on 19 November (Figure 22). This resulted in the gradually decreasing increment widths observed at the shell margin in clams collected in December 1980 through March 1981 (Table 19). Water temperatures were below 6°C (with minor fluctuations above this level) from 21 December 1980 to 1 March 1981, and did not rise above 10°C until 1 April, or 14°C until 12 April 1981 (Figure 22). The rising temperatures in March and early April resulted in the resumption of growth observed in most clams collected during these months (Table 19). Furthermore, water temperatures rose above 20°C by early May 1981, which accounted for the gradually increasing increment widths observed after the growth cessation mark in clams collected in May and June. The period of no growth, as discerned from increment width and growth cessation mark observations in clams collected from December 1980 to June 1981, was approximately early December 1980 to mid-March 1981. This period was very similar to the period during which temperatures remained below 6°C (Figure 22).

Winter growth cessation marks were not always visible (or distinct) in the microstructure of light bands (see Results sections I.B.2. and II.B.1.b.). In order for a winter growth cessation mark to be distinct, a light band formed in fall must separate it from the summer dark band. Four of twenty-seven T and TI clams collected after 4 December 1980 did not have a distinct winter growth cessation mark in the fall 1980 to spring 1981 light band (Table 19; see Figure 11E). There was evidence to suggest that these four clams resumed growth earlier in spring 1981 and grew for fewer days in summer 1980 than other

T and TI clams (see Appendix). This relationship has implications on possible patterns of seasonal growth by hard clams in lower Chesapeake Bay, which will be discussed in the following section.

C. Seasonal band formation by Mercenaria mercenaria
in lower Chesapeake Bay

Hard clams in lower Chesapeake Bay deposit a dark band in the middle homogenous layer during summer and early fall. This band was designated the annulus of the hard clam, since it was formed, with very few exceptions, only once each year by every experimental and wild clam analyzed. Distinct winter growth cessation marks were not found to be such consistent features of annual increments in hard clam shell microstructure. This must be due to individual variation in the magnitude of growth during fall, for it is a light band formed in fall which makes a winter growth cessation mark appear distinct.

Distinct winter growth cessation marks were common, but not consistent features of annual increments of clams younger than 8 years of age. This was exemplified by their presence in all but four T and TI clams collected after the winter of 1980-1981. This means that these clams had a growth rate increase in fall, during which time a light band was formed. Growth ceased entirely during winter, but resumed in spring as temperatures increased. Such a sequence of events formed a light band with a distinct winter growth cessation mark within it. This annual pattern of shell growth, called Spring to Fall growth, was characterized by a wide diffuse dark band (representing slow, summer growth) and a light band with a distinct winter growth cessation mark (representing faster growth in fall and spring, and no growth in

winter). This was the most common annual shell growth pattern observed in clams younger than 8 years of age.

One other pattern of annual shell growth was observed, but predominately in old hard clams. As clams aged beyond 8 years, light bands were formed in fall and winter by a smaller percentage of the population, indicating that growth rates were low from summer through fall and winter (when low temperatures prohibited growth). Consequently, only spring and possibly early summer remained for light band formation by older clams, and no distinct winter growth cessation mark would be formed. This annual growth pattern was also observed in some annual increments of clams younger than 8 years of age, as in the four T and TI clams discussed previously (and in the Appendix). This annual shell growth pattern, called Late Winter to Summer growth, was characterized by a narrow, deeply colored dark band with narrow daily increments (representing slow growth in mid-summer and fall) and a wide light band composed of wide daily increments with no growth cessation mark (representing fast growth in spring and early summer).

Individual clams did not have annual shell growth patterns throughout their entire growth histories which were solely characterized by pattern [1] (Spring to Fall growth) or [2] (Late Winter to Summer growth). Growth patterns often changed from year to year. However, annual increments deposited by all clams when they were older than 15 years of age were exclusively pattern [2]. Since distinct winter growth cessation marks were not features of annual shell increments in pattern [2], dark bands were the only structures suitable for use in age determination in all clams.

DISCUSSION

I. The annulus in Mercenaria mercenaria shells

Hard clams analyzed from lower Chesapeake Bay and its tributaries formed a single dark band in the middle homogenous layer each year during summer and early fall. Thus, dark bands are annuli in hard clam shell microstructure and are suitable for use in age determination. Furthermore, dark bands were associated with narrower daily increments than light bands, indicating that hard clam growth rates were slower in summer and early fall than in spring and late fall. Winter growth cessation marks were not found to be consistent features of annual shell increments of hard clams in lower Chesapeake Bay. As such, winter growth cessation marks did not conform to the definition of an annulus (Tesch 1971). These observations on seasonal hard clam shell microstructure were validated in both wild and experimental clams, which had a maximum of 13 years of monitored growth. The duration of monitored growth by experimental clams in this study is believed to be the longest of any study of bivalve shell microstructure.

The validity of bands, lines, or zones in the microstructure of bivalve shells as representations of annual periodicities has been established for species other than M. mercenaria. These include Mya arenaria (MacDonald and Thomas 1980), Arctica islandica (Thompson et al. 1980), and Spisula solidissima (Jones et al.

1978), as well as a species closely related to M. mercenaria, M. campechiensis (Saloman and Taylor 1969). Furthermore, in each species listed above, annulus formation was associated with decreased growth rates caused either by seasonal temperature changes and/or shifting of the metabolic machinery to reproductive effort.

Only 6% of the experimental clams in lots I, II, XI, and XIV did not form the expected number of dark bands in the 1973-1977 growth period (Results section I.A.2.). This was regarded as the error estimate of this age determination technique and is within acceptable limits (Tesch 1971). However, a larger sample size than that used here is suggested if studies of age and growth or population dynamics are to be conducted.

Dark band counts were also more accurate than the size-frequency method of age determination. This was exemplified by the Y group of wild clams (see Table 1; Figure 3). Shell heights at capture of the seven Y clams were 60.9, 62.4, 68.1, 68.4, 68.7, 69.3, and 69.4 mm. At least the last five clams listed (shell heights of 68.1-69.4 mm) would most probably be assigned to the same age class in a size-frequency analysis. However, the age of each clam determined by dark band counts was 14, 11, 20, 32, 13, 16, and 25 years, respectively. The large range in size at age observed in this small sample may, thus, preclude the use of the size-frequency method for determining age of hard clams in lower Chesapeake Bay.

This is the first study of seasonal microstructure of M. mercenaria shells in lower Chesapeake Bay. Other studies, which also resulted in methods of age determination, were conducted on

populations from along its latitudinal range (Gulf of St. Lawrence to the Gulf of Mexico; Franz and Merrill 1980).

Studies of hard clam shell microstructure north of Chesapeake Bay (Massachusetts, Connecticut, New York, and New Jersey) dealt primarily with periodicity of formation and seasonal width variation of prismatic increments (Pannella and MacClintock 1968; Rhoads and Pannella 1970; Greene 1975; Kennish and Olsson 1975; Thompson 1975). However, there was no discussion of association of wide or narrow daily increments with bands in the middle homogenous layer. The method of age determination which resulted from these studies involved investigation of seasonal changes in increment width (growth rate) and counting winter growth cessation marks. Thus, winter growth cessation marks were annuli in shells of hard clams north of Chesapeake Bay.

Studies on shell microstructure of hard clams south of Chesapeake Bay (Georgia) were concerned with seasonal band (or 'zone') formation in the middle homogenous layer (Clark 1979). Dark bands (or 'transparent zones') were: 1) formed each summer and early fall, and 2) associated with narrower daily increments than light bands (or 'opaque zones') in hard clams from Georgia. Clark's (1979) results concerning dark band formation and its designation as an annulus in clam shells are in agreement with those from this study conducted in lower Chesapeake Bay. However, hard clams in Georgia apparently grow throughout winter, since no distinct winter growth cessations were observed (Clark 1979).

Results of studies discussed above, as well as from this study, suggest latitudinal gradients in seasonal hard clam shell microstructure. Both dark band formation and decreased growth rates in summer appear to be restricted to populations of hard clams in

Chesapeake Bay and those to the south. Dark bands are also annuli in shells of hard clams in this region. Distinct winter growth cessations were inconsistent features of annual increments in Virginia, but were annuli in shells of northern populations and not present in southern populations of hard clams. Consequently, the seasonal shell microstructure as well as the annulus of hard clam shells appear to vary along its latitudinal range. This is similar in concept to changes with latitude observed in the seasonal ultrastructure of the inner shell layer of Geukensia demissa (Lutz 1977; Lutz and Rhoads 1978; Lutz and Castagna 1980). As was emphasized by Lutz and colleagues, latitudinal variation in the ultra- or microstructure of annual shell increments of a species may preclude application of a defined annulus to all populations along its range.

Seasonal changes in growth rates of hard clams along its latitudinal range as deduced from shell microstructural analyses are in agreement with results of shell-size monitoring studies. Trends in formation of both winter growth cessation marks and dark bands by clams (see previous paragraph) are reflected in the length of the growing season and presence of summer growth rate reductions, respectively, observed in shell-size monitoring studies. Shell growth is limited to summer in Canadian hard clam populations (Kerswill 1941), but extends throughout the year in populations off North Carolina (Chestnut et al. 1957) and Florida (Menzel 1963; 1964). This is in direct agreement with the trend in formation of winter growth cessations with decreasing latitude. Summer growth rate reductions were observed only in clam populations in Virginia (Haven and Andrews 1957), North Carolina (Chestnut et al. 1957), and Florida (Menzel 1963; 1964). This is also

in agreement with the restriction of dark band and narrow daily increment formation in summer to hard clams in Chesapeake Bay and to the south (this study; Clark 1979).

Latitudinal variation in seasonal temperature range is probably the most important factor regulating seasonal shell growth by hard clams (Pratt and Campbell 1956; Ansell 1968; Rhoads and Pannella 1970). However, there is little evidence to support the contention that the optimum range of temperature for shell growth changes with latitude (Ansell 1968). This range (15-25°C) appears to be relatively constant for all populations of hard clams examined (Ansell 1968). Consequently, hard clam shell microstructure reflects ambient seasonal cycles of temperature at the location of growth (Lutz and Rhoads 1980), necessitating examination of shells from local hard clam populations to determine the annulus and the time of year of its formation.

II. Daily increments and analyses of growth in Mercenaria mercenaria

A. Periodicity and number in annual shell increments

Experimental hard clams formed one prismatic increment during each solar day that each individual was active. Thus, the 1:1 relationship between increments and days was stronger during short periods of monitored shell growth (e.g. 4 months during summer by TI clams) than during extended periods which included one or more winters. Periods of inactivity of indeterminate duration were represented by growth cessation marks. The season of formation of either a series of daily increments or a growth cessation mark was determined by its

location in either a light or dark (summer) band. Furthermore, the percent agreement between counts of daily increments and days in known annual shell increments in experimental clams decreased with increasing age. Consequently, experimental clams were active and growing for a decreasing proportion of days in each year with increasing age.

Daily increment formation has also been documented in several other bivalve species, including Chione fluctifraga (Crabtree et al. 1979/1980) and Meretrix lusoria (Koike 1975). The number of daily increments in one annual shell increment of C. fluctifraga decreased with increasing age (Crabtree et al. 1979/1980); this relationship was also found in Mercenaria mercenaria (this study).

Results of this study on the periodicity of increment formation by hard clams are in agreement with those of others. Pannella and MacClintock (1968) first reported the existence of daily increments in hard clam shells and laboratory experiments yielding similar results were conducted by Thompson (1975). However, Pannella and MacClintock (1968) and subsequently, Kennish and Olsson (1975) and Kennish (1980), stated that one daily increment was formed by Mercenaria mercenaria every solar day regardless of season or age (up to 8 years old). This is a surprising result of their studies, since each analyzed hard clams north of Chesapeake Bay, where winter growth cessation marks were annuli in shell microstructure (Pannella and MacClintock (1968): Massachusetts and Connecticut; Kennish and Olsson (1975) and Kennish (1980): New Jersey). Each annual shell increment would thus contain approximately 365 daily increments and age estimates (in years) could be obtained by dividing the total number of daily increments formed during the lifetime of a clam by 365 (Kennish 1980). The results of this study on

M. mercenaria and those of Crabtree et al. (1979/1980) on Chione fluctifraga shed doubt on the accuracy of this method of age determination.

Decreasing percent agreements between numbers of daily increments and days in annual shell increments with increasing age (this study; Crabtree et al. 1979/1980) may also preclude use of such counts in astrophysical calculations. Berry and Barker (1968), Pannella et al. (1968) and Pannella (1975) used counts of daily increments in fossil bivalves to calculate lengths of the day, month, and year in the geologic past. However, the range of percent agreement in any single year-class, as well as its decrease with increasing age would require use of both a large sample size and clams of the same age from each geologic time. These conditions would have to be met to safely conclude that observed changes in cycle length were actual and not artifacts of individual variation (Berry and Barker 1975).

Lunar periodicities undoubtedly affect both width and 'complexity' of daily increments in hard clams (Pannella and MacClintock 1968; MacClintock and Pannella 1969; Thompson 1975; Pannella 1976), but these were not investigated in this study. Bivalves which inhabit intertidal regions, such as Cerastoderma edule (Richardson et al. 1979; 1980) and Clinocardium nuttalli (Evans 1972) form one outer shell layer increment during each tidal immersion and emersion. Tides at the T and TI series location were semi-diurnal, with two high tides of approximately the same height occurring each lunar day. If the subtidal T and TI clams had formed one increment in response to a single high and low tide (every 12.5 h), coefficients of regressions relating numbers of increments and solar days would have been approximately 0.5.

Without the stimulus of periodic immersions and emersions, subtidal hard clams apparently form increments in response to circadian events only, such as light and dark cycles, temperature changes, or plankton migrations (Thompson 1975).

B. Seasonal growth rates

Hard clams of all ages examined in this study had narrower average daily increment widths associated with dark bands than with light bands, indicating that growth rates were slower in summer than in spring or fall. Clark (1979), in his study of hard clams off Georgia, also reported that daily increments associated with dark bands were narrower than those associated with light bands. However, he did not present any data to support this claim. Studies on seasonal growth rates of hard clams from northern populations, particularly those from New Jersey (Kennish and Olsson 1975; Kennish 1980) have shown that summer daily increment widths ranged between 15 and 150 $\mu\text{m}/\text{increment}$, while widths of increments formed in fall through spring ranged between $>1-50 \mu\text{m}/\text{increment}$. These figures represent the range in widths of individual daily increments formed in each season. These are not average widths of increments associated with light or dark bands in the middle homogenous layer (or average daily growth rates for each season), as reported in this study. Consequently, direct comparisons of average seasonal growth rates obtained from daily increment width measurements along the latitudinal range of hard clams are not possible. However, it appears that summer growth rates are faster in northern hard clams (Kennish and Olsson 1975; Kennish 1980) than in those from Virginia

(this study) and Georgia (Clark 1979). Furthermore, growth rates in winter appear to be faster in clams south of Chesapeake Bay (Clark 1979), than in those to the north (Kennish and Olsson 1975; Kennish 1980).

Average widths of daily increments reported in this study also revealed large variation among individual clams in seasonal growth rates, particularly with age. Almost all clams older than 8 years and some younger clams had very low growth rates in fall and winter. An annual shell increment in these consisted of a dark band formed in summer and early fall and a light band formed in spring, with no distinct winter growth cessation mark (called Late Winter to Summer growth in Results section II.C.). Younger clams however, tended to grow quickly in both spring and fall, slower in summer and not at all during a short period in winter. An annual shell increment in these clams consisted of a dark band formed in summer and early fall and a light band formed in fall through spring which contained a distinct winter growth cessation (called Spring to Fall growth in Results section II.C.). Farrow (1971) also reported that growth in cockles, Cerastoderma edule, became increasingly limited to spring and summer with age. In hard clams of lower Chesapeake Bay, though, the summer dark band was the only universal feature of annual shell increments of clams of all ages. This was due to the tendency for growth to be restricted to spring, summer, and early fall with age and the concomitant lack of formation of distinct winter growth cessations.

C. Environmental changes recorded in shell microstructure

Analyses of daily increment widths and patterns of growth cessation marks were useful in this study in describing effects of both traumatic (e.g. tropical storm Agnes) and relatively mild (e.g. elevations in water temperature) environmental changes on hard clam growth. Effects of tropical storm Agnes resulted in decreases in both the number of days of growth and growth rates of hard clams in the summer of 1972. Also, four temperature maxima in the summer of 1980 were represented in some T and TI clams by four growth cessation marks or periods of reduced growth rate in the dark band.

Decreased growth rates as well as an increase in mortality of hard clams in 1972 in the York and James Rivers were previously linked with reduced salinities caused by tropical storm Agnes (Haven et al. 1973; Loesch and Haven 1973; Haven et al. 1976). However, this is the first study which documents these effects on shell growth in microstructure, as well as their restriction to the summer of 1972. The suggestion of Kennish and Olsson (1975) and Kennish (1977) that hard clams be used to monitor effects of thermal effluent of power-generating stations is further testimony to the quality of information on environmental change stored in hard clam shell microstructure. Growth cessation marks, patterns of increment width, and bands in the middle homogenous layer reflect changes in the micro-environment of each individual. With adequate knowledge of the magnitude of individual variation in response to change, patterns of microstructural growth in hard clam and other bivalve shells could be a successful tool for monitoring present environmental change (Kennish and Olsson 1975;

Kennish 1977; Jones 1981) as well as that from the geologic past (Rhoads and Pannella 1970; Berry and Barker 1975; Pannella 1976; Jones 1980).

CONCLUSIONS

1. Hard clams (Mercenaria mercenaria) in lower Chesapeake Bay form a single dark band in the middle homogenous shell layer each summer and early fall. Thus, dark bands are annuli in hard clam shells. Distinct winter growth cessation marks within light bands (formed in fall through spring) were not consistent features of annual shell increments (see conclusions 2 and 4).
2. Differences in band formation in fall through spring were evident among age groups of clams. Clams 8 years old and younger had a greater tendency to form light bands in this period than older clams. Thus, the month of collection must be known to assign age to the last complete or incomplete annulus formed by both young and old clams.
3. Experimental hard clams formed one increment in the prismatic shell layer during each solar day that individuals were active. Periods of inactivity were represented by growth cessation marks, or thick organic lines in the prismatic layer. As periods of monitored growth increased in duration to include one or more winters, the one-to-one increment to day relationship became weaker. Furthermore, periods of inactivity during a year became longer as age increased.

4. Dark bands in the middle homogenous layer of experimental clams were associated more often with narrower daily increments than light bands. Median average daily increment widths associated with dark bands (formed in summers of 1969 through 1971) ranged between 21-33 $\mu\text{m}/\text{inc}$. Similar measurements of increments in light bands formed in the same years ranged between 31-44 $\mu\text{m}/\text{inc}$. Decreased hard clam growth rates in summer were most probably due to water temperatures above the optimum range for shell growth (15-25°C; Ansell 1968).
5. Analysis of daily increments, growth cessation marks, and bands in experimental clams revealed two types of seasonal growth which were dependent on age (see conclusion 2):
 - a) Spring to Fall growth (8 years old and younger) - Annual shell increments were characterized by both a wide dark band formed in summer and a light band formed in fall through spring containing a distinct winter growth cessation mark. Thus, two distinct marks were formed in each annual shell increment: a dark band and a winter growth cessation mark. Clams which formed this type of annual increment had a period of faster growth in fall than in summer, as well as a period of no growth in winter.
 - b) Early Winter to Summer growth (over 8 years old) - Annual shell increments were characterized by a narrow dark band formed in summer and a light band formed the following spring with no distinct winter growth cessation mark. Clams which formed this type of annual increment lacked a period of faster growth in fall, and the period of no growth may have extended from late summer through winter.
6. Daily increments and growth cessation marks accurately represent the effects of environmental change on shell growth. For example, both the number of days of growth and the average growth rate of experimental clams (ages 4-12) in the summer of 1972 were reduced due to the effects of tropical storm Agnes. Furthermore,

four temperature maxima (above the optimum range for shell growth) in the summer of 1980 were evident in microstructure as a series of either four growth cessation marks or growth rate reductions.

APPENDIX

Four T and TI clams (two collected on both 31 May and 27 June 1981; Table 19) did not have a distinct winter growth cessation in the fall 1980 to spring 1981 light band. (These clams were mentioned previously in Results section I.B.2. with regards to gross band structure and annulus definition. One of these four is also pictured in Figure 11E). Consequently, this light band represents a period of uninterrupted growth prior to collection equal in days to the number of daily increments counted within it (Appendix Table 1). Clams with distinct winter growth cessations which were also collected on 31 May and 27 June 1981 had a period of uninterrupted growth prior to collection equal in days to the number of increments from the growth cessation to the shell margin (Table 19).

Clams without distinct winter growth cessations appeared to have resumed shell growth earlier in spring than clams with them. Three of four clams with no distinct winter growth cessations had greater number of increments in the shell margin light band than other clams collected on the same date had from the growth cessation to the shell margin (Table 19 and Appendix Table 1). The two clams collected on 31 May without a winter growth cessation had an uninterrupted growth period prior to collection of 93 and 96 days (Appendix Table 1). The other two clams collected on that date which had distinct winter growth cessations, had similar periods of 62 and 112 days in duration (Table 19). Furthermore, both clams

Appendix Table 1. Data on the Spring 1981 light band and Summer 1980 dark band in the 4 clams (Table 19) which did not have a winter growth break in the light band.

| Collection Date | No. of Clams | Spring 1981 Light Band | | | Summer 1980 Dark Band | | |
|-----------------|--------------|------------------------|---------------|--------------------------|-----------------------|---------------|--------------------------|
| | | # of Increments | μm | $\mu\text{m}/\text{inc}$ | # of Increments | μm | $\mu\text{m}/\text{inc}$ |
| 5/31/81 | 2 | 93 | 3974.4 | 42.9 | 40 | 345.6 | 8.7 |
| | | 96 | 3726.0 | 38.8 | 106 | 1771.2 | 16.7 |
| 6/27/81 | 2 | 179 | 7560.0 | 42.2 | 82 | 1242.0 | 15.1 |
| | | 152 | 5000.4 | 32.8 | 62 | 648.0 | 10.4 |

collected on 27 June which did not have a distinct winter growth cessation had longer uninterrupted growth periods than did those with distinct growth cessations collected on that date (Table 19 and Appendix Table 1). Consequently, three of four clams without distinct winter growth cessations resumed growth earlier in spring than clams with them.

Another feature of the growth history of each of these four clams was the narrow dark band formed in the summer of 1980 (Appendix Table 1; see Figure 11E). The number of increments, or days of growth, in the summer 1980 dark band averaged 72, or approximately one-half the average number in all complete summer 1980 dark bands analyzed (136; see Table 18). Consequently, not only did these four clams resume growth earlier in spring, but they also grew for fewer days in summer than other T and TI clams. These two aspects of the growth history of T and TI clams with no distinct winter growth cessations were based on only four clams, which is admittedly a small sample. However, when this information is coupled with all other data presented previously, a more complete picture of the possibilities for seasonal growth by hard clams in lower Chesapeake Bay is obtained (see Results section II.C.).

BIBLIOGRAPHY

- Ansell, A. D. 1968. The rate of growth of the hard clam (Mercenaria mercenaria (L)) throughout the geographical range. J. Cons. perm. int. Explor. Mer 31: 364-409.
- Austin, H. M. and D. S. Haven. 1981. A report on the operation of a hydraulic escalator dredge on private ground on Hampton Flats, James River, during October 1980. Mar. Res. Rept. 81-3. VIMS, Gloucester Point, VA 23062. 41 p.
- Barker, R. M. 1964. Microtextural variations in pelecypod shells. Malacologia 2: 69-86.
- Belding, D. L. 1912. A report upon the quahog and oyster fisheries of Massachusetts, including the life history, growth, and cultivation of the quahog (Venus mercenaria) and observations on the set of oyster spat in Wellfleet Bay. Mass. Div. Mar. Fish. Contrib. No. 12. 134 pp.
- Berry, W. B. N. and R. M. Barker. 1968. Fossil bivalve shells indicate longer month and year in Cretaceous than present. Nature 217: 938-939.
- Berry, W. B. N. and R. M. Barker. 1975. Growth increments in fossil and modern bivalves. Pp. 9-27 in Growth Rhythms and the History of the Earth's Rotation, G. D. Rosenberg and S. K. Runcorn (eds.), John Wiley and Sons, London.
- Castagna, M. and J. N. Kraeuter. 1981. Manual for growing the hard clam Mercenaria. Spec. Rept. No. 249 in Appl. Mar. Sci. and Ocean Engineering. VIMS, Gloucester Point, VA 23062. 110 p.
- Chestnut, A. F., W. E. Fahy, and H. J. Porter. 1957. Growth of young Venus mercenaria, Venus campechiensis, and their hybrids. Proc. Nat. Shellfish. Ass. 47: 50-56.
- Clark, G. R. 1979. Seasonal growth variations in the shells of recent and prehistoric specimens of Mercenaria mercenaria from St. Catherines Island, Georgia. Anthropol. Pap. Am. Mus. Nat. Hist. 56: 161-179.
- Crabtree, D. M., C. D. Clausen, and A. A. Roth. 1979/1980. Consistency in growth line counts in bivalve specimens. Palaeogeog., Palaeoclim., Palaeoecol. 29: 323-340.

- Crenshaw, M. A. and J. M. Neff. 1969. Decalcification at the mantle-shell interface in molluscs. *Am. Zool.* 9: 881-885.
- Dey, N. D. and E. T. Bolton. 1978. Tetracycline as a bivalve shell marker. *Proc. Nat. Shellfish. Ass.* 68: 77.
- Dugal, L. P. 1939. The use of calcareous shell to buffer the products of anaerobic glycolysis in Venus mercenaria. *J. Comp. Cell. Physiol.* 13: 235-251.
- Evans, J. W. 1972. Tidal growth increments in the cockle, Clinocardium nuttalli. *Science* 176: 416-417.
- Farrow, G. E. 1971. Periodicity structures in the bivalve shell. Experiments to establish growth controls in Cerastoderma edule from the Thames estuary. *Paleontology* 14: 571-588.
- Franz, D. R. and A. S. Merrill. 1980. Molluscan distribution patterns on the continental shelf of the middle Atlantic Bight (Northwest Atlantic). *Malacologia* 19(2): 209-225.
- Gordon, J. and M. R. Carriker. 1978. Growth lines in a bivalve mollusc: Subdaily patterns and dissolution of the shell. *Science* 202: 519-521.
- Greene, G. T. 1975. Incremental shell growth patterns as affected by environment in Mercenaria mercenaria. B.A. Thesis, Princeton University, 77 pp.
- Hargis, W. J., Jr. 1974. A preliminary report on effects of tropical storm Agnes on Chesapeake Bay. Pp. 6-29 in Studies on Certain Impacts of Tropical Storm Agnes on the Chesapeake Bay and its Tributaries, W. J. Hargis, Jr. (P.I.), Final Report Grant No. 04-3-158-10 from U. S. Dept. of Commerce, NOAA, to Virginia Inst. Mar. Sci., Gloucester Pt., VA 23062.
- Haskin, H. H. 1954. Age determination in molluscs. *Trans. New York Acad. Sci.* (2) 16: 300-304.
- Haven, D. and J. D. Andrews. 1957. Survival and growth of Venus mercenaria, Venus campechiensis, and their hybrids in suspended trays and on natural bottoms. *Proc. Nat. Shellfish. Ass.* 47: 43-49.
- Haven, D. S., W. J. Hargis, Jr., J. G. Loesch, and J. P. Whitcomb. 1976. The effects of tropical storm Agnes on oysters, hard clams, soft clams, and oyster drills in Virginia. Pp. 488-507 in The effects of tropical storm Agnes on the Chesapeake Bay estuarine system, J. Davis (proj. coord.), Chesapeake Bay Research Consortium Publ. No. 54.

- Haven, D. S., J. G. Loesch, and J. P. Whitcomb. 1973. A study of the rate of growth of the hard clam in various regions of Chesapeake Bay. Pp. 59-75 in An Investigation into Commercial Aspects of the Hard Clam Fishery and Development of Commercial Gear for the Harvest of Molluscs, Final Report Contract No. 3-124-R, Virginia Inst. Mar. Sci., Gloucester Pt., VA 23062.
- Jones, D. S. 1980. Annual cycle of shell growth increment formation in two continental shelf bivalves and its paleoecological significance. *Paleobiology* 6(3): 331-340.
- Jones, D. S. 1981. Annual growth increments in shells of Spisula solidissima record marine temperature variability. *Science* 211: 165-167.
- Jones, D. S., I. Thompson, and W. Ambrose. 1978. Age and growth rate determinations for the Atlantic surf clam, Spisula solidissima (Bivalvia: Mactracea) based on internal growth lines in shell cross-sections. *Mar. Biol.* 47: 63-70.
- Kato, Y. and I. Hamai. 1975. Growth and shell formation of the surf clam, Spisula sachalinensis (Shrenck). *Bull. Fac. Fish. Hokkaido Univ.* 25: 291-303.
- Kennish, M. J. 1977. Growth increment analysis of Mercenaria mercenaria from artificially heated coastal marine waters: A practical monitoring method. Pp. 663-669 in Proc. XII Inter. Soc. Chronobiol. Conf., Washington, D. C.
- Kennish, M. J. 1980. Shell microgrowth analysis: Mercenaria mercenaria as a type example for research in population dynamics. Pp. 255-294 in Skeletal Growth of Aquatic Organisms: Biological Records of Environmental Change, D. C. Rhoads and R. A. Lutz (eds.), Plenum Press, New York.
- Kennish, M. J. and R. K. Olsson. 1975. Effects of thermal discharges on the microstructural growth of Mercenaria mercenaria. *Environmental Geology* 1: 41-64.
- Kerswill, C. J. 1941. Some environmental factors limiting growth and distribution of the quahog, Venus mercenaria L. Ph.D. Diss., Univ. Toronto, Canada. 104 pp.
- Koike, H. 1975. The use of daily and annual growth lines of the clam Meretrix lusoria in estimating seasons of Jomon period shell gathering. *Inter. Assoc. Quat. Res. Conf.* 9: 189-193.
- Loesch, J. G. and D. S. Haven. 1973. Estimated growth functions and size-age relationships of the hard clam, Mercenaria mercenaria, in the York River, Virginia. *The Veliger* 16: 76-81.

- Loosanoff, V. L. 1939. Effect of temperature upon shell movements of clams (Venus mercenaria). Biol. Bull. 76: 171.
- Lutz, R. A. 1977. Annual structural changes in the inner shell layer of Geukensia (=Modiolus) demissa. Proc. Nat. Shellfish. Ass. 67: 120.
- Lutz, R. A. and M. Castagna. 1980. Age composition and growth rate of a mussel (Geukensia demissa) population in a Virginia salt marsh. J. Moll. Stud. 46: 106-115.
- Lutz, R. A. and D. C. Rhoads. 1977. Anaerobiosis and a theory of growth line formation. Science 198: 1222-1227.
- Lutz, R. A. and D. C. Rhoads. 1978. Shell structure of the Atlantic ribbed mussel, Geukensia demissa (Dillwyn): A re-evaluation. Bull. Amer. Malacol. Union 44th Ann. Mtg. Pp. 13-17.
- Lutz, R. A. and D. C. Rhoads. 1980. Growth patterns within the molluscan shell: an overview. Pp. 203-254 in Skeletal Growth of Aquatic Organisms: Biological Records of Environmental Change, D. C. Rhoads and R. A. Lutz (eds.), Plenum Press, New York.
- MacClintock, C. and G. Pannella. 1969. Time of calcification in the bivalve mollusk, Mercenaria mercenaria, during the 24-hour period. Geol. Soc. Amer., Ann. Mtg. Prog. 1: 140.
- MacDonald, B. A. and M. L. H. Thomas. 1980. Age determination of the soft-shell clam, Mya arenaria, using shell internal growth lines. Mar. Biol. 58: 105-109.
- MacPhail, J. S. 1961. A hydraulic escalator shellfish harvester. Fish. Res. Bd. Can. Bull. No. 128. 24 p.
- Mason, J. 1957. The age and growth of the scallop, Pecten maximus (L.), in Manx waters. J. mar. biol. Ass. U. K. 36: 473-492.
- Menzel, R. W. 1963. Seasonal growth of the northern quahog, Mercenaria mercenaria, and the southern quahog, M. campechiensis, in Alligator Harbor, Florida. Proc. Nat. Shellfish. Ass. 52: 37-46.
- Menzel, R. W. 1964. Seasonal growth of northern and southern quahogs, Mercenaria mercenaria and M. campechiensis, and their hybrids in Florida. Proc. Nat. Shellfish. Ass. 53: 111-119.
- Miller, W. S., E. M. Wallace, C. N. Shuster, and R. E. Hillman. 1975. Hard clam: the gourmet's delight. Leaflet No. 14, Atlantic States Mar. Fish. Comm., Wash., D. C. 8 p.
- NOAA. 1974-1981. U. S. Dept. Commerce, Current Fisheries Statistics. Release Nos. 6116, 6415, 6715, 6915, 7215, 7513, 7815, and 8015.

- Pannella, G. 1975. Paleontological clocks and the history of the Earth's rotation. Pp. 253-285 in Growth Rhythms and the History of the Earth's Rotation, G. D. Rosenberg and S. K. Runcorn (eds.), John Wiley and Sons, London.
- Pannella, G. 1976. Tidal growth patterns in recent and fossil mollusc bivalve shells. *Naturwissenschaften* 63: 539-543.
- Pannella, G. and C. MacClintock. 1968. Biological and environmental rhythms reflected in molluscan shell growth. *J. Paleontol.* 42(5;Suppl.): 64-80.
- Pannella, G., C. MacClintock, and M. N. Thompson. 1968. Paleontological evidence of variations in length of the synodic month since Late Cambrian. *Science* 162: 792-796.
- Pratt, D. M. and D. A. Campbell. 1956. Environmental factors affecting growth in Venus mercenaria. *Limnol. Oceanog.* 1: 2-17.
- Rhoads, D. C. and G. Pannella. 1970. The use of molluscan shell growth patterns in ecology and paleoecology. *Lethaia* 3: 143-161.
- Richardson, C. A., D. J. Crisp, and N. W. Runham. 1979. Tidally deposited growth bands in the shell of the common cockle, Cerastoderma edule (L.). *Malacologia* 18: 277-290.
- Richardson, C. A., D. J. Crisp, N. W. Runham, and Ll. D. Gruffydd. 1980. The use of tidal growth bands in the shell of Cerastoderma edule to measure seasonal conditions. *J. mar. Biol. Ass. U. K.* 60: 977-989.
- Ricker, W. E. 1975. Computation and interpretation of biological statistics of fish populations. *Fish. Res. Bd. Can. Bull.* No. 191. 382 p.
- Ropes, J. W. and L. O'Brien. 1979. A unique method of ageing surf clams. ICEES, CM1979/K:2F. Shellfish and Crustacea Committee. 5 pp.
- Saloman, C. H. and J. L. Taylor. 1969. Age and growth of large southern quahogs from a Florida estuary. *Proc. Nat. Shellfish. Ass.* 59: 46-51.
- Sokal, R. R. and F. J. Rohlf. 1969. *Biometry*. W. H. Freeman and Co., San Francisco. 776 pp.
- Stewart, W. N. and T. N. Taylor. 1965. The peel technique. Pp. 224-232 in *Handbook of Paleontological Techniques*, B. Kummel and D. Raup (eds.), W. H. Freeman and Co., San Francisco.

- Tesch, F. W. 1971. Age and growth. Pp. 98-130 in Methods for assessment of fish production in freshwaters, W. E. Ricker (ed.), Inter. Biol. Prog. Handbook No. 3, 2nd Edition, Blackwell Scientific Publications, Oxford.
- Thompson, I. 1975. Biological clocks and shell growth in bivalves. Pp. 149-163 in Growth Rhythms and the History of the Earth's Rotation, G. D. Rosenberg and S. K. Runcorn (eds.), John Wiley and Sons, London.
- Thompson, I., D. S. Jones, and D. Dreibelbis. 1980. Annual internal growth banding and life history of the ocean quahog, Arctica islandica (Mollusca: Bivalvia). Mar. Biol. 57: 25-34.
- Walford, L. A. 1946. A new graphic method of describing the growth of animals. Biol. Bull. 90: 141-147.
- Weymouth, F. W. 1923. The life history and growth of the pismo clam (Tivela stultorium Mawe). Fish. Bull. No. 7, Calif. Fish and Game Comm. 120 pp.

VITA

Lowell William Fritz

Born in Rochester, New York on 5 November 1954. Graduated from Penfield High School, Penfield, New York in June 1972 and from Bucknell University, Lewisburg, Pennsylvania, in May 1976 (A.B. degree).

Entered School of Marine Science, College of William and Mary in September 1977. Employed as graduate assistant in Departments of Estuarine Processes and Chemical Oceanography (September 1977-June 1979) and Applied Biology (July 1979-June 1982). Received M.A. degree in Marine Science May 1982.