

---

VIMS Articles

---

1998

## Effects of periodic environmental hypoxia on predation of a tethered polychaete, *Glycera americana*: implications for trophic dynamics

JA Nestlerode  
*Virginia Institute of Marine Science*

RJ Diaz  
*Virginia Institute of Marine Science*

Follow this and additional works at: <https://scholarworks.wm.edu/vimsarticles>



Part of the [Marine Biology Commons](#)

---

### Recommended Citation

Nestlerode, JA and Diaz, RJ, "Effects of periodic environmental hypoxia on predation of a tethered polychaete, *Glycera americana*: implications for trophic dynamics" (1998). *VIMS Articles*. 196.  
<https://scholarworks.wm.edu/vimsarticles/196>

This Article is brought to you for free and open access by W&M ScholarWorks. It has been accepted for inclusion in VIMS Articles by an authorized administrator of W&M ScholarWorks. For more information, please contact [scholarworks@wm.edu](mailto:scholarworks@wm.edu).

# Effects of periodic environmental hypoxia on predation of a tethered polychaete, *Glycera americana*: implications for trophic dynamics

Janet A. Nestlerode\*, Robert J. Diaz

College of William and Mary, School of Marine Science, Virginia Institute of Marine Science, Gloucester Point, Virginia 23062, USA

**ABSTRACT:** Hypoxia and anoxia have significant deleterious ecological effects on living resources throughout many estuarine and marine ecosystems worldwide. Brief periods of low oxygen have the potential to facilitate transfer of benthic production to higher trophic levels as many benthic infaunal species have shallower sediment depth distributions during hypoxic events. In August–September 1994, a time-lapse camera equipped with a water quality datalogger was used to document *in situ* exploitation of a tethered prey organism (*Glycera americana* Leidy) by mobile fish and crustacean predators during alternating normoxia-hypoxia cycles in the York River, Virginia, USA. Based on photographic and diver observations, this hypoxia-induced benthic-pelagic transfer of production is more likely to occur when environmental dissolved oxygen concentrations rise above an apparent threshold between 1 and 2 ml l<sup>-1</sup>. When oxygen concentrations decline below approximately 1.5 ml l<sup>-1</sup> (30% O<sub>2</sub> saturation), the response of the predator to increased prey availability is abruptly interrupted. There is no energy gain by the predator until oxygen concentrations rise above this critical threshold level. It is suggested that predators return to affected areas and resume feeding activity before stressed infauna are able to return to normal positions in the sediment.

**KEY WORDS:** Hypoxia · Predation · Trophic dynamics · Chesapeake Bay · Demersal predators · Blood worm · *Glycera americana*

## INTRODUCTION

Environmental dissolved oxygen depletion in subpycnocline waters has significant deleterious ecological effects on living resources in many ecosystems throughout the world (reviewed by Diaz & Rosenberg 1995). The occurrence of hypoxic (dissolved oxygen <2 ml l<sup>-1</sup>; Tyson & Pearson 1991) water masses has been reported as a common feature in fjords (Richards 1965, Diaz & Rosenberg 1995), lakes (Wetzel 1983), near-coastal areas (Stachowitsch 1984, Swanson & Parker 1988, Weigelt 1991, Rabalais et al. 1994), and estuaries (Pihl et al. 1991, Welsh & Eller 1991). In many shallow marine systems, oxygen concentrations decline primarily during the summer when the depletion

of oxygen in the process of decomposition of carbon fluxed from previous high levels of primary production combines with density stratification of the water column which isolates bottom waters from reaeration (Kuo & Neilson 1987, Rabalais et al. 1991). Shoreward migrations into oxygenated regions and mass mortalities of demersal fishes and crustaceans have been reported in conjunction with low oxygen events (Loesch 1960, May 1973, Stachowitsch 1984, Pihl et al. 1991). Although detrimental to some species, hypoxic conditions may facilitate the transfer of benthic production to higher trophic levels as many benthic infaunal species have shallower sediment depth distributions during hypoxic events than before or after the onset of hypoxia (Diaz et al. 1992). Since burial in the sediment provides refuge (Diaz et al. 1992, Pihl et al. 1992), these stressed organisms are more susceptible to predation.

\*E-mail: janetn@vims.edu

The severity and consequences of hypoxic events on benthic systems varies with the intensity, extent, and frequency of low dissolved oxygen events and the relative ability of various species and groups to withstand exposure to physiologically stressful or lethal dissolved oxygen concentrations (Llansó 1992, Pearson & Rosenberg 1992). The majority of benthic fauna have limited mobility, and migration out of hypoxic regions is not possible (Josefson & Widbom 1988, Llansó 1992). Through a combination of behavioral and physiological adaptations, however, fluctuating and short-term hypoxia is survivable by these organisms (Diaz & Rosenberg 1995).

Many species that are unable to escape hypoxic conditions initiate a series of sub-lethal responses to oxygen stress. For example, sea cucumbers swell to increase their surface area:volume ratio to promote oxygen uptake through the body surface and to store oxygen in the increased volume of coelomic fluid (Astall & Jones 1991). As oxygen concentrations decline, many infaunal organisms migrate to the sediment surface and eventually emerge from the sediment when oxygen concentrations are slightly higher than those invoking mortality in the species (Llansó 1992, Rosenberg et al. 1992, Nilsson & Rosenberg 1994). Bivalves increase pumping rates, extend their siphons above the bottom in search of oxygenated water, decrease burrowing rates, increase exposure of parts or all of their bodies on the sediment surface, and/or reduce activity levels (Jørgensen 1980, Tyson & Pearson 1991, Pihl et al. 1992). Worms emerge from their burrows and begin undulatory body movements which draw water down from above in an attempt to enhance surrounding oxygen levels (Llansó 1991, Tyson & Pearson 1991). If dissolved oxygen concentrations continue to fall, the worms' activity ceases and they lie quiescent on the sediment surface until succumbing to death (Tyson & Pearson 1991). However, if hypoxic episodes are brief (on the order of hours or days) many species that become limp and motionless can recover from oxygen depletion and reburrow within 30 min after oxygen conditions improve (Jørgensen 1980, Diaz et al. 1992).

Some macrobenthic mortality and reduced biomass in oxygen-deficient waters may be the result of increased predation resulting from these behavioral modifications induced by low oxygen stress (Pihl et al. 1992, Sandberg 1994). Because benthic invertebrates vary in their ability to tolerate hypoxia and in their vulnerability to predators, periods of benthic hypoxia could lead to selective predation on some taxa and be influential in structuring benthic communities (Kolar & Rahel 1993, Sandberg & Bonsdorff 1996).

Brief periods of hypoxia may facilitate the transfer of benthic production to predator species (Diaz &

Schaffner 1990). Two possible explanations of this transfer of prey to predators during hypoxic events have been suggested (Pihl et al. 1991, 1992, Pihl 1994). First, fish may migrate out of hypoxic waters, returning for temporary feeding 'excursions' during hypoxia to exploit exposed infauna driven out of the sediment by the oxygen stress. Second, fish may return just after the oxygen levels rise and feed on easily accessible infauna prey items that have not yet fully recovered from stress.

The functional relationship between macrobenthic invertebrates and demersal fishes is a significant component in energy flow within estuarine ecosystems (Baird & Ulanowicz 1989). One would expect, based on the background synthesis of information, that predators would only subject themselves to abiotic stress if it led to energetic benefits otherwise unavailable to them. Consequently, energy rewards of locating food must outweigh the physiological expense of foraging in low oxygen environments.

During summer, low dissolved oxygen is a characteristic feature of bottom waters of Chesapeake Bay, USA (Officer et al. 1984, Kuo & Neilson 1987). This physical stress has the potential to influence trophic dynamics between predators and their benthic prey species throughout affected systems. Demersal predator assemblages in subtidal parts of the lower York River, Chesapeake Bay, are dominated by spot *Leiostomus xanthurus* Lacépède, Atlantic croaker *Micropogonias undulatus* Linnaeus, hogchoker *Trinectes maculatus* Bloch & Schneider, and blue crab *Callinectes sapidus* Rathburn (Land et al. 1996). Spot and Atlantic croaker use the York primarily as a nursery area, with juveniles present in the estuary from spring to autumn (Chao & Musick 1977). Spot are more tolerant of low oxygen concentrations than Atlantic croaker, with spot able to survive at least 4 d at 1.2 to 1.9 ml l<sup>-1</sup> (24 to 36% O<sub>2</sub> saturation) (Pihl et al. 1991). The diet of these sciaenid fishes consists primarily of benthic polychaetes and crustaceans (Roelofs 1954, Chao & Musick 1977, Pihl et al. 1992). Hogchoker is a year-round resident of the river (Land et al. 1996) and feeds primarily on polychaetes (Pihl et al. 1992). This fish is tolerant of low oxygen, surviving at least 10 d at 0.7 ml l<sup>-1</sup> (14% O<sub>2</sub> saturation) (Pihl et al. 1991). Adult and juvenile blue crabs utilize the river throughout the year (Land et al. 1996). This opportunistic benthic omnivore is very sensitive to hypoxia and responds to low dissolved oxygen by migrating out of affected areas and returning when conditions improve (Pihl et al. 1991, Das & Stickle 1993).

The objective of this study was to examine the effect of hypoxia on food acquisition behavior of bottom-feeding predators through field observations and specifically to address whether epibenthic predators,

such as demersal fishes and crustaceans, enter hypoxic water masses to feed on stressed macrobenthic infauna driven out of the sediment by low oxygen concentrations during or immediately after hypoxia.

## MATERIALS AND METHODS

**Study area.** The York River estuary, a sub-estuary of Chesapeake Bay, is located in southeastern Virginia, USA. Study sites were located in the York off Gloucester Point (37° 15' N, 76° 30' W) near the Virginia Institute of Marine Science in approximately 17 and 21 m of water (Fig. 1). This system experiences periodic summer hypoxia. Deep areas of the lower reaches of the York experience periodic hypoxic events that can last from days to weeks (Haas 1977, Kuo & Neilson 1987, Diaz et al. 1992). The forcing mechanism driving the fortnightly cycle of establishment and breakdown of hypoxic conditions in the York is the lunar neap-spring tidal cycle (Haas 1977). Decreased turbulent mixing during a neap tide leads to a stratified water column and, consequently, hypoxic conditions in the isolated bottom water layer. Increased mixing associated with increased tidal currents during spring tides lead to a shift from a stratified, hypoxic water column to a more homogeneous, normoxic water column (Haas 1977). Superimposed on the neap-spring hypoxia cycle is a semi-diurnal tidal signal that affects short-term oxygen fluctuation (Diaz et al. 1992). Low-oxygen, high-salinity bottom water from the mainstem of Chesapeake Bay moves upriver

on a flood tide. Higher dissolved oxygen concentrations are typically associated with bottom waters on a falling tide (Diaz et al. 1992, Kuo & Park 1993). The regular periodicity of these cycles allows an opportunity to anticipate normoxic and hypoxic conditions in the bottom waters of deep areas of the river.

**Data collection.** Observational field experiments were conducted over 2 hypoxic (dissolved oxygen  $< 2 \text{ ml l}^{-1}$ ) events. Prey organisms (Polychaeta: *Glycera americana* Leidy) were attached to an aluminum camera frame (Fig. 2) and placed in an area of the York River known to undergo hypoxia during the summer ( $> 15 \text{ m}$  depth) (Kuo & Neilson 1987, Diaz et al. 1992). *G. americana* was chosen as the prey organism primarily because it was found in the gut contents of demersal fishes from the York River (Pihl et al. 1992). It is also large enough to be easily seen in the photographs and is commercially available as fish bait. Predator activity was monitored using a time-lapse underwater camera (Benthos model 372A) mounted directly above the prey.

A self-contained water quality datalogger (Hydrolab Datasonde 3) was mounted on the camera frame 20 cm above the sediment surface and used to record near-bottom water column conditions (i.e. dissolved oxygen, salinity, temperature, pH). The Datasonde was calibrated prior to each deployment. Sensor data were compared with Winkler oxygen titrations of bottom water samples and found to be accurate.

During the first camera deployment (26 August to 9 September 1994), a water quality reading was taken every 5 min and 1 photograph was taken every

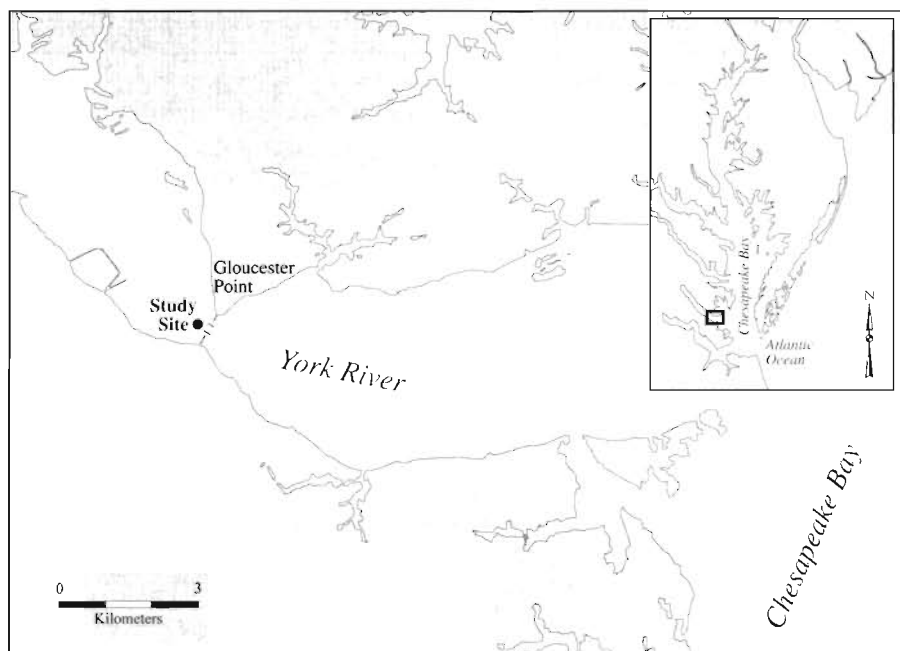

Fig. 1. Lower York River study area, USA. Camera frame apparatus was deployed southwest of Gloucester Point (study site indicated by ●)

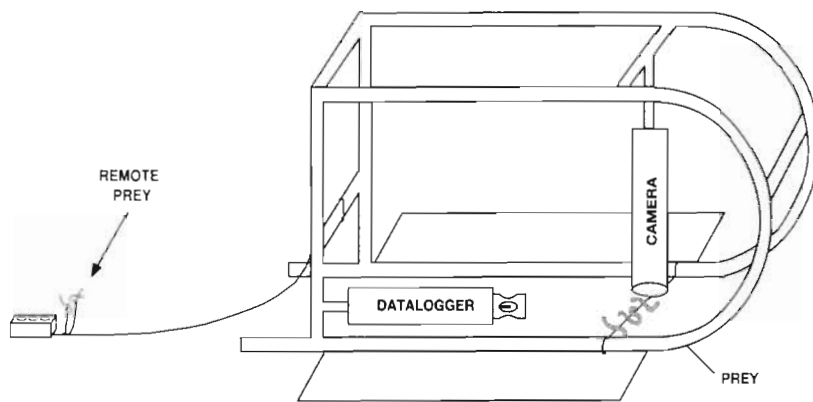

Fig. 2. Illustration of camera frame apparatus deployed in lower York River

15 min. Unfortunately, the power system for the camera strobes was unreliable, which resulted in gaps in the photographic record. In an effort to prolong battery life during the second deployment (16 to 22 September 1994) exposure frequency was changed to once per hour. Each photograph frame was inscribed with the date and time the image was taken and facilitated matching photographs with dissolved oxygen readings.

Ten *Glycera americana* were tethered by monofilament across the short axis of the frame under the camera within the  $15 \times 30$  cm field of view. Small lead sinkers were placed on the monofilament to keep the worms on the sediment surface and within the camera's focus range. Bait was replaced daily (weather permitting) by divers at slack tide. Any remaining worms were removed before fresh bait was attached to the frame. Tethered worms placed on the sediment surface were intended to mimic the natural infaunal emergence response to hypoxic conditions (Tyson & Pearson 1991). Active burrowing into the sediment by *G. americana* was not observed during any deployment and tethering was ultimately lethal to the prey organisms. Because prey were replaced at sufficient frequencies and before decomposition of the worms could take place, it is believed that the ultimate lethality of tethering did not affect predation. Although the presence of infaunal organisms exposed on the sediment surface is not normal under normoxic conditions, predation pressures can be compared by exposing tethered prey during both hypoxia and normoxia.

As a control for structure effects (e.g. attraction of predators to the frame), a baited line was extended 2 m away from the frame and anchored in place with a cement brick. Prey were attached to this line 0.25 m from the brick with monofilament and fishing hooks. Presence or disappearance of bait attached to this line was monitored daily by divers.

## RESULTS

### Environmental conditions

Two hypoxic events (28 August to 4 September 1994 and 16 to 19 September 1994) occurred. Temporal patterns of near-bottom dissolved oxygen concentrations coincided with the neap/spring tidal cycle as predicted by Haas (1977) and also displayed a semi-diurnal signal that coincided with tidal stage (Fig. 3).

The camera frame was deployed on 25 August 1994 in 21 m water depth ( $37^{\circ} 14' 39''$  N,  $76^{\circ} 30' 33''$  W) at the onset of a neap tide cycle. Approximately 2 d following camera deployment, divers discovered that the frame was sinking into the soft mud sediment. The entire apparatus was immediately retrieved, creating a gap in the water quality data time series, and modified to prevent sinking. The frame was re-deployed to the same site on 30 August 1994. By the time of re-deployment, the near-bottom dissolved oxygen concentration was nearly anoxic and remained well below  $2 \text{ ml l}^{-1}$  ( $37\%$   $\text{O}_2$  saturation) for the following 4 d. Dissolved oxygen values below  $2 \text{ ml l}^{-1}$  were recorded until 8 September (Fig. 3). The salinity ranged from 19.7 to 28.0‰ S over the course of this camera deployment and the bottom water temperature ranged from 22.8 to 25.4°C.

The camera frame was re-deployed on 16 September 1994 in 17 m water depth ( $37^{\circ} 14' 43''$  N,  $76^{\circ} 30' 30''$  W) during the peak of a neap tide cycle. Near-bottom dissolved oxygen concentrations remained below  $2 \text{ ml l}^{-1}$  until 19 September, the onset of a spring tide cycle. Dissolved oxygen values below  $2 \text{ ml l}^{-1}$  were recorded until 21 September (Fig. 3). Near-bottom water salinities ranged from 20.6 to 25.9‰ S and temperatures ranged from 21.8 to 24.1°C during this camera deployment.

### Predation events

Prey were made available on 15 occasions during 2 consecutive hypoxic-normoxic cycles. During 2 prey deployments (prey deployments 8 and 15 in Table 1), 2 separate predation events occurred, resulting in a total of 17 independent episodes. Predation occurred on 11 of these 17 occasions (Table 1). Predators were the blue crab *Callinectes sapidus*, and a feeding-pit producing demersal fish, such as spot *Leiostomus xanthurus*. Although the photographic record is often incomplete due to camera malfunction and severe tur-

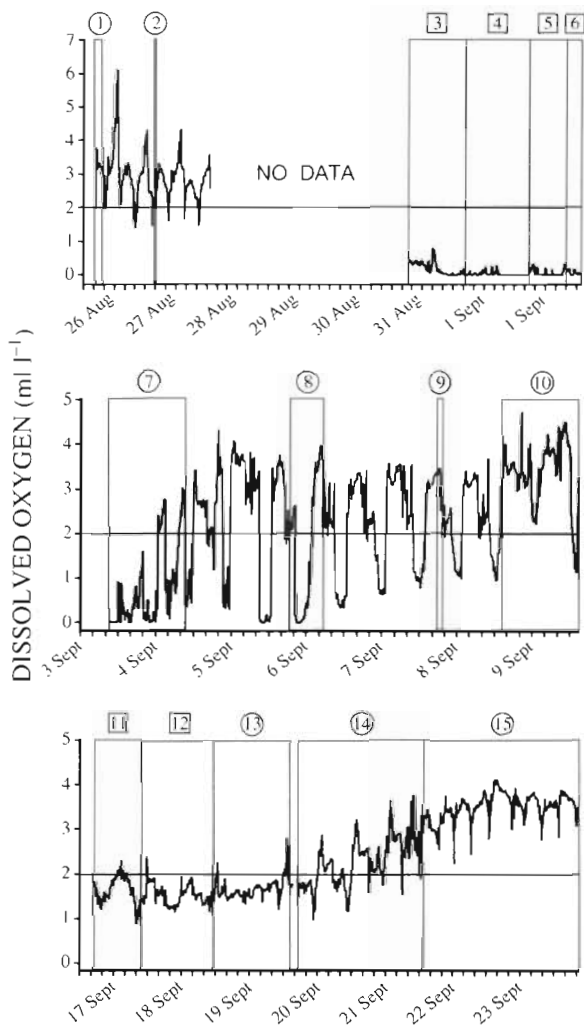

Fig. 3. Near-bottom dissolved oxygen concentrations (measured 20 cm above the sediment surface at 5 min intervals) during baited camera deployments, August and September 1994, lower York River. Horizontal axis is labeled at 4 h intervals starting at midnight of the date indicated. Shaded areas represent duration of prey deployments. Numbers above shaded areas correspond with prey deployments listed in Table 1. Circled numbers: prey deployments in which predation occurred; numbers in squares: prey deployments in which predation did not occur

bidity that made many photographs dark or unclear, the time predation events occurred could be narrowed into 'predation windows' based on clear photographs and diver observations. Diver observations were included to incorporate prey deployments for which there is no photographic record. The presence or absence of previously set prey was noted by divers prior to each new prey deployment (for deployments with and without photographic records). Time of day of this observation was noted to obtain the corresponding environmental dissolved oxygen concentration from

the water quality data. For instances of partial predation (e.g. 6 out of 10 worms removed) the initial observation is considered 'prey absent' and subsequent observations are considered 'prey present' until the next indication of predation. Examples of images from the photographic record are shown in Fig. 4.

Presence and absence of prey on the remote baited line corresponded with that of the prey attached to the camera frame. No worms were ever missing from the remote site unless they were also missing from under the camera. When there was no predation on remote prey, there was also no predation on the worms positioned under the camera.

Using Fisher's Exact Test (Agresti 1990), the null hypothesis of independence between predation and occurrence of hypoxia can be rejected ( $p < 0.001$ ). Based on a total of 485 independent photographic and diver observations and 2 oxygen concentration intervals, the odds of tethered prey remaining when the dissolved oxygen concentration was  $< 2 \text{ ml l}^{-1}$  (calculated from the conditional probabilities of prey presence, 0.86, divided by prey absence, 0.14) was 6.2. When the dissolved oxygen was  $> 2 \text{ ml l}^{-1}$ , the odds of prey being present (calculated from the conditional probabilities of prey presence, 0.07, divided by prey absence, 0.93) was 0.1. The ratio of these odds (odds ratio =  $82.8 \pm \text{SE} = 18.2$ ) indicated that tethered prey were 82.8 times more likely to be present when near-bottom dissolved oxygen concentration was  $< 2 \text{ ml l}^{-1}$  than when near-bottom dissolved oxygen was  $> 2 \text{ ml l}^{-1}$ .

Based on mean dissolved oxygen levels for each predation and non-predation event (Table 1), prey deployments were grouped into 4 dissolved oxygen concentration intervals (Table 2). A logistic regression model was constructed using the upper limit values of each interval to predict the probability of predation based on dissolved oxygen concentration (Fig. 5). The difference in predicted predation probabilities between dissolved oxygen intervals varied along the dissolved oxygen gradient. At low and high oxygen concentrations, the differences were small. However, predation probability changed rapidly with dissolved oxygen concentration and differences were greater at intermediate oxygen levels. These categorized dissolved oxygen data indicated a predation threshold somewhere between 1 and  $2 \text{ ml l}^{-1}$ ; however, if these data are examined individually (Table 1), it appears that this threshold is approximately midway within this interval at 1.5 to  $1.8 \text{ ml l}^{-1}$  (30 to 36%  $\text{O}_2$  saturation). There was a significant relationship between dissolved oxygen concentration and odds of predation [logistic regression,  $G^2(\text{M})$  goodness of fit statistic = 11.6, 1 df,  $\alpha < 0.001$ ] (Fig. 5). The predicted dissolved oxygen concentration at which the odds of predation were

Table 1. *Glycera americana*. Summary of observations and near-bottom dissolved oxygen (DO) concentrations for each prey deployment in York River, August–September 1994

Prey deployment	Min./max. DO during deployment (ml l <sup>-1</sup> )	Did predation occur?	Length of predation window	Min./max. DO during predation window (ml l <sup>-1</sup> )	Mean DO during predation window or non-predation prey set (ml l <sup>-1</sup> )	DO category (ml l <sup>-1</sup> )	Comments and observations:
1	3.0/3.3	Yes	2 h 25 min	3.0/3.3	3.2	3.0–3.9	First photograph taken 2 h 25 min after prey introduction; by that time all prey items had been removed from the monofilament
2	2.2/2.8	Yes	15 min	2.6/2.8	2.5	2.0–2.9	Prey items were set when DO was declining toward hypoxia but not yet hypoxic; 35 min after prey introduction, a blue crab ( <i>Callinectes sapidus</i> ) was photographed preying on worms (Fig. 4A). In the next photograph taken 15 min later, all prey items were removed from the monofilament and the crab was gone
3	0/0.8	No			0.2	0–0.9	Prey were set after the onset of a hypoxic event (Fig. 4B)
4	0/0.3	No			0	0–0.9	Divers observed infaunal anemones <i>Edwardsia elegans</i> and holothuroids <i>Sclerodactyla briareus</i> rolling across the sediment surface with the current
5	0/0.3	No			0.1	0–0.9	
6	0/0.3	No			0.1	0–0.9	
7	0/3.0	Yes	2 h 55 min	0.4/3.0	2.1	2.0–2.9	Prey were set near the end of a hypoxic event. An emerged <i>E. elegans</i> was photographed as it rolled through the camera's field of view (DO = 0.1 ml l <sup>-1</sup> ) (Fig. 4C). Within the 2 h 55 min predation window, the DO remained continuously normoxic for 1 h 55 min. A sediment disturbance (resembling a demersal fish feeding pit) was observed
8	0/4.0	Yes	4 h 10 min	0/2.6	0.2	0–0.9	Prey were set during near-hypoxic conditions. Due to camera malfunction, a photograph was not taken until 4 h 10 min after prey introduction. During the first 1 h 45 min of this predation window, DO ranged from 1.9 to 2.6 ml l <sup>-1</sup> until a rapid decline to anoxic conditions occurred over a 30 min period. Due to the lack of a complete photographic record, it is unclear at what DO the predation of 4 worms occurred
9	2.5/3.5	Yes	1 h 15 min	2.5/3.5	3.1	3.0–3.9	During this predation window, DO steadily climbed from 0.6 to 4.0 ml l <sup>-1</sup> . Predation of the remaining 6 worms occurred sometime within this period
10	1.1/4.7	Yes	23 h 20 min	1.1/4.7	3.4	3.0–3.9	The first photograph was taken 1 h 15 min after prey introduction and by that time all prey items had been removed from the monofilament
11	0.9/2.3	No			1.6	1.0–1.9	Due to camera malfunction there is no photographic record of this prey deployment and evidence is based on diver observations. DO during this prey deployment remained normoxic except for a 1 h 40 min period
12	1.1/2.4	No			1.5	1.0–1.9	DO remained hypoxic during this prey deployment except for a 3 h period in which DO fluctuated between 1.9 and 2.3 ml l <sup>-1</sup>
13	1.2/2.8	Yes	9 h 20 min	1.2/2.8	1.8	1.0–1.9	DO remained hypoxic during this prey deployment except for a 20 min period in which the oxygen briefly peaked to 2.4 ml l <sup>-1</sup>
14	0.9/3.8	Yes	19 h 50 min	0.9/3.8	2.3	2.0–2.9	Predation of 6 worms occurred
15	2.2/3.7	Yes	30 min	3.3/3.5	3.5	3.0–3.9	Due to camera malfunction there is no photographic record of this prey deployment and evidence is based on diver observations
							Eight hours after prey introduction, a blue crab ( <i>Callinectes sapidus</i> ) was photographed preying on worms. In the next photograph taken 30 min later, 5 worms had been removed from the monofilament and the crab was gone
							The remaining 5 worms remained undisturbed for the next hour and predation occurred sometime within the following 9 h 25 min

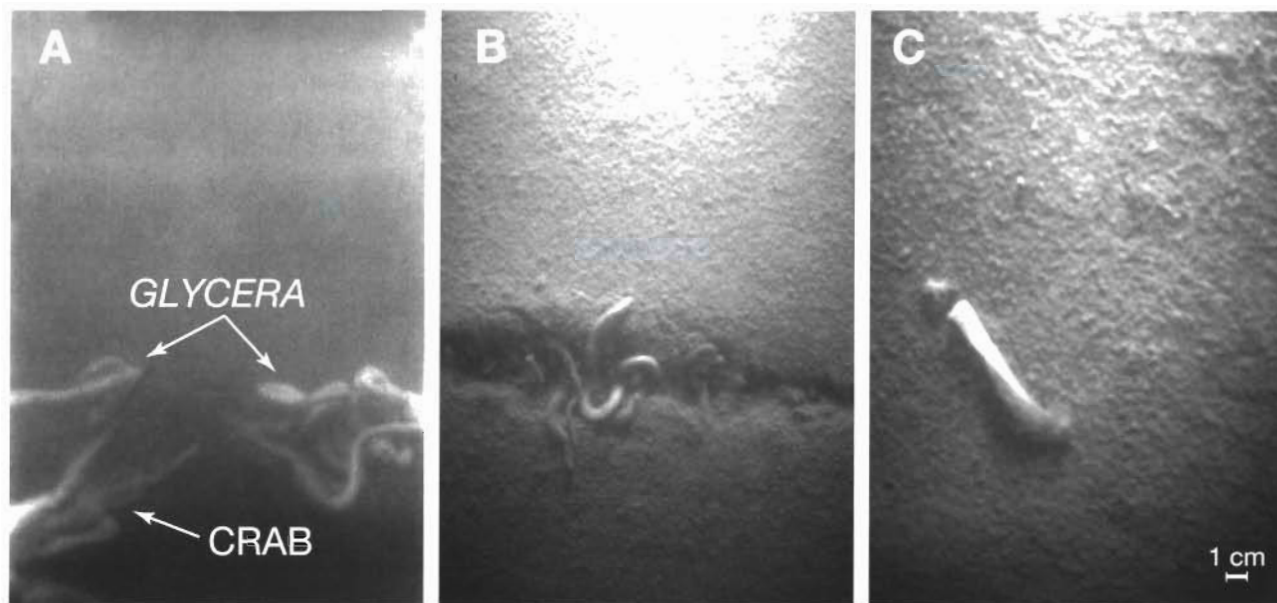

Fig. 4. *Glycera americana*. Images taken from photographic record of baited, surface, time-lapse camera deployments. (A) Thirty-five minutes after prey introduction (dissolved oxygen,  $DO = 2.6 \text{ ml l}^{-1}$ ), a blue crab *Callinectes sapidus* preying on worms; in the next photograph (not shown here) taken 15 min later, all prey items had been removed. (B) Ten *G. americana* tethered under camera ( $DO = 0.2 \text{ ml l}^{-1}$ ). (C) *Edwardsia elegans*, an infaunal burrowing anemone, rolling across the sediment surface ( $DO = 0.1 \text{ ml l}^{-1}$ )

even (50:50) was  $1.87 \text{ ml l}^{-1}$ . At this oxygen level, there is a 50% chance that emerged benthic infauna will be preyed upon by nektonic predators.

## DISCUSSION

Many estuarine systems around the world experience seasonally mild to severe hypoxia or anoxia (Whitledge 1985, Diaz & Rosenberg 1995). These low dissolved oxygen conditions in bottom waters contribute to the major reduction of living resources of many estuarine and coastal systems (Harper et al. 1981, Baden et al. 1990, Desprez et al. 1992). The responses of benthic community structure to seasonal hypoxia were found to be consistent between ecosys-

tems and to depend mainly on the frequency and duration of the hypoxia (Diaz & Rosenberg 1995). The basic behavioral modifications benthic infauna use to survive oxygen deficiency potentially enhance their vulnerability to predators (Diaz et al. 1992, Kolar & Rahel 1993). Nektonic predator species are not immune to low dissolved oxygen concentrations and respond mainly through avoidance of affected areas (Pihl et al. 1991, Breitburg 1992, Das & Stickle 1994). The dissipation of hypoxia, however, may lead to an opportunistic response by predators to increased availability of hypoxia-stressed prey.

Fluctuating hypoxia and normoxia may facilitate the transfer of benthic secondary production to mobile predator species (Diaz & Rosenberg 1995, Diaz & Schaffner 1990). The mechanism that dramatically increases the chances of predation (the odds ratio) is the behavioral response of the infauna to hypoxia. As bottom water oxygen concentrations decrease, many infaunal organisms migrate to the sediment surface and are available to predators at higher densities than during normoxic periods (Jørgensen 1980, Stachowitsch 1984, Llansó 1991, Tyson & Pearson 1991, Diaz et al. 1992). During this study, divers observed infaunal anemones *Edwardsia elegans* Verrill and

Table 2. *Glycera americana*. Near-bottom dissolved oxygen intervals in  $\text{ml l}^{-1}$  summarized for the 17 predation and non-predation events with corresponding observed and predicted predation probabilities

Dissolved oxygen ( $\text{ml l}^{-1}$ )	No. of predation events observed	No. of non-predation events observed	Observed proportional predation	Predicted proportional predation
0–0.9	1	4	0.20	0.02–0.10
1.0–1.9	1	2	0.33	0.12–0.52
2.0–2.9	4	0	1.0	0.57–0.91
3.0–3.9	6	0	1.0	0.93–0.99



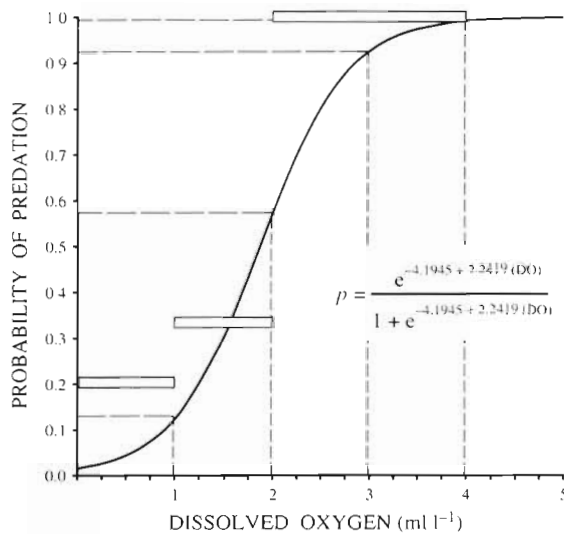

Fig. 5. Logistic regression curve [ $G^2(M/I)$  goodness of fit statistic = 11.6, 1 df,  $\alpha < 0.001$ ]. Curve is the predicted relationship between dissolved oxygen concentration and predation based on the given equation ( $p$  = probability of predation; DO = dissolved oxygen concentration in  $\text{ml l}^{-1}$ ). Shaded bars represent observed proportional predation (Table 2). Dashed lines illustrate varying differences in predicted predation probabilities between DO intervals along a DO gradient

holothuroideans *Sclerodactyla briareus* Leseur fully emerged from the sediment during nearly anoxic periods.

Patches of dense prey are more intensely exploited than low density patches (Free et al. 1977, McCall & Fleeger 1993), and therefore, since oxygen-stressed infauna are concentrated at the sediment surface, they are more susceptible to predation if foragers can migrate into and out of affected areas (Pihl et al. 1991). Since predator-prey dynamics in systems that experience hypoxic stress may have important implications for energy flow, it is important to determine conditions at which this transfer of energy does or does not take place. This study suggests that predators are likely to take advantage of hypoxia-stressed infaunal organisms once environmental dissolved oxygen concentrations rise above the 1 to 2  $\text{ml l}^{-1}$  threshold. Below this level, the functional response of the predator to increased prey availability is interrupted.

The possibility exists that a predator's functional response may be modified by hypoxia. The time predators spend foraging is likely to change due to elevated stress (Abrams 1982). In this study, the rate of predation changed with increasing and decreasing sublethal abiotic stress. A large increase in predation pressure is predicted over a limited range of dissolved oxygen values. At low dissolved oxygen concentrations, if the encounter rate with prey is enhanced by their concentration at the sediment surface due to oxygen

stress, then predator feeding thresholds may be lowered substantially such that there is a loss of the low-density refuge for the prey. Conversely, if there is a loss of feeding efficiency for the predators due to low dissolved oxygen concentrations, then the threshold may be increased for the predatory behavior. Although this predation experiment used one tethered prey species maintained on the surface of the sediment, our results are applicable to predicting predation pressure on emerged infaunal species by demersal predators in hypoxic systems. Pihl et al. (1992) found that after hypoxic events both the size and species richness of prey items taken by demersal feeding fish increased.

Under normoxic regimes, when infauna are burrowed within the sediment and less susceptible to predation, we may assume that available prey density does not yield maximum predation rates. Based on typical functional response models, we can then expect that an increase in available prey density would lead to a general increase in prey consumption (Eggleston 1990, Valiela 1995). However, the results of this study suggest that, although densities of available prey are enhanced, predatory behavior is interrupted during hypoxia (Fig. 6). Under normoxic conditions the transfer of energy to predators can be characterized by a functional response model, with the time interval prior to hypoxia representing a steady net energy transfer level (A in Fig. 6). When dissolved oxygen concentrations drop below approximately 2.0  $\text{ml l}^{-1}$ , predators escape low oxygen areas (Diaz & Rosenberg 1995). Predation begins to decline when dissolved oxygen concentrations drop below 2  $\text{ml l}^{-1}$  and ceases abruptly somewhere between 1.5 and 2.0  $\text{ml l}^{-1}$  (B in Fig. 6). When dissolved oxygen drops rapidly, the change in predation may resemble a threshold response. As oxygen concentrations increase and become tolerable to predator species, predators quickly move back into the affected areas and may lead to a pulse in trophic transfer from the increase in the amount of energy gain from predation on oxygen-stressed macrobenthos (C in Fig. 6). Hypoxia induced behavioral and physiological stress on these prey species potentially makes them more vulnerable to predation and available at higher densities.

Surviving stressed benthic infauna confined to the affected area require a recovery period on the order of minutes or hours following a hypoxic stress (Jørgensen 1980, Llansó 1991) to reburrow and resume normal activity. However, the predators' abilities to avoid hypoxic regions eliminates the need for a recovery time from oxygen stress before feeding can commence. Following a hypoxic event, but before infaunal recovery, the chances of predation of hypoxic-stressed infauna by nektonic predators increases with increas-

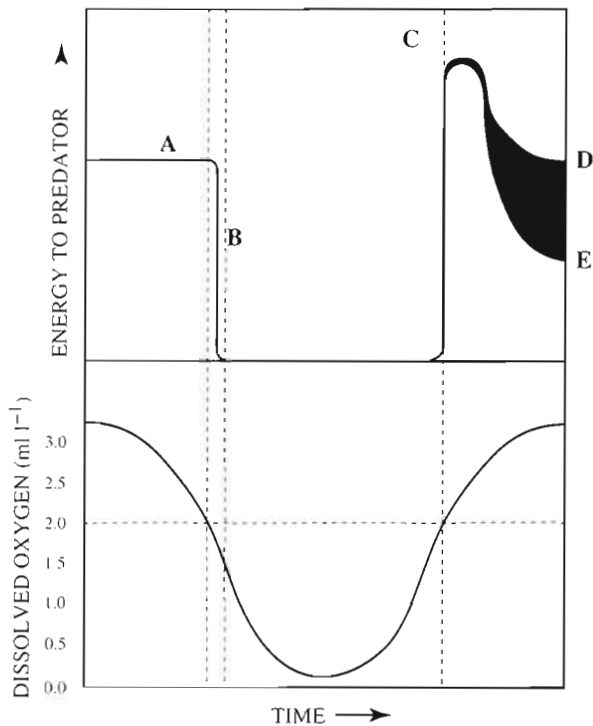

Fig. 6. Hypothetical patterns of energy transfer to predators in response to declining and increasing environmental dissolved oxygen (DO) concentrations. Under normoxic conditions the transfer of energy to predators can be characterized by steady net energy transfer level (A). As predators escape low oxygen areas, predation begins to decline when DO concentrations drop below  $2 \text{ ml l}^{-1}$  and ceases completely when DO concentrations drop below  $1.5 \text{ ml l}^{-1}$  (B). When DO drops rapidly, the change in predation resembles a threshold response. As oxygen concentrations increase and become tolerable to predator species, predators quickly move back into the affected areas. There may be an initial increase in the amount of energy gain from predation on oxygen-stressed macrobenthos (C). With recovery and reburrowing of prey organisms over time, the elevated level of energy transfer to predators declines to the pre-hypoxic condition (D). If significant numbers of prey are removed, either by predators or hypoxia-induced mortality, the predation rate may be altered and the energy transfer to the predators could be further reduced below pre-hypoxic levels (E)

ing dissolved oxygen concentration. The predators are able to move into affected areas as soon as oxygen levels are tolerable and take advantage of the increased prey availability before the prey organisms recover and reburrow in the sediment.

With recovery and reburrowing of prey organisms over time, the elevated level of energy transfer to predators declines to the pre-hypoxic condition and the predator activity may return to its pre-hypoxic state (D in Fig. 6). The pulse of available energy that follows a hypoxic event may temporarily benefit predators, but in the long term altered energy flow patterns (i.e. reduced prey productivity) could leave predators with

reduced resources later in the season (Diaz & Rosenberg 1995). If significant numbers of prey are removed, either by predators or hypoxia-induced mortality, the predation rate may be altered and the energy transfer to the predators could be further reduced below pre-hypoxic levels (E in Fig. 6). The level of reduction will be a function of the production capacity of the prey.

Seasonal hypoxia or anoxia in bottom waters is an important element in influencing secondary productivity and is dependent on the intensity and duration of the habitat's exposure to low oxygen conditions (Rainer & Fitzhardinge 1981, Diaz & Rosenberg 1995). While  $2 \text{ ml l}^{-1}$  is widely accepted as the definitional boundary for hypoxia (Tyson & Pearson 1991), in fact, serious system responses are seen at or below this level (Diaz & Rosenberg 1995). In terms of predation in oxygen stressed systems, this study demonstrates critical oxygen levels that affect trophic dynamics are, more specifically, between  $1$  and  $2 \text{ ml l}^{-1}$  (20 to 37%  $\text{O}_2$  saturation). Previous investigations have reported effects of oxygen deficiency at the population level based on trawl or trap data and dissolved oxygen concentrations (Pavela et al. 1983, Burd & Brinkhurst 1984, Pihl 1989, Pihl et al. 1991). This study takes a community level approach and examines the effects of fluctuating oxygen concentrations on the function of the species as prey or predator.

Because infaunal species differ in their ability to tolerate and recover from oxygen stress, periods of benthic hypoxia could influence benthic community structure through hypoxia-induced mortality and predation (Kolar & Rahel 1993, Nilsson & Rosenberg 1994). This investigation emphasizes the importance of considering the potential ability of a predator to avoid, yet maintain proximity to, hypoxic areas in the understanding of energy flow in hypoxic systems. More detailed, *in situ* studies on the recovery rates of prey species to hypoxia are needed to fully understand the effect of altered predation pressure during and after hypoxic stress.

*Acknowledgements.* The authors thank M. Cavalluzzi, T. Chisholm, G. Cicchetti, R. Cutter, D. Gouge, E. Hinchey, M. Lara, T. Orrell, A. Pile, R. Seitz, and E. Wooden for field assistance; A. Kuo, R. Lipcius, M. Luckenbach, M. Patterson, L. Sanderson, and 3 anonymous reviewers for comments on previous versions of the manuscript; and H. Burrell, K. Stubblefield, and D. Taylor for producing illustrations and figures. This is contribution number 2112 to the Virginia Institute of Marine Science.

#### LITERATURE CITED

- Abrams PA (1982) Functional responses of optimal foragers. *Am Nat* 120:382-390  
 Agresti A (1990) *Categorical data analysis*. John Wiley & Sons, New York

- Astall CM, Jones MB (1991) Respiration and biometry in the sea cucumber *Holothuria forskali*. *J Mar Biol Assoc UK* 71: 73–81
- Baden SP, Loo L, Pihl L, Rosenberg R (1990) Effects of eutrophication on benthic communities including fish: Swedish west coast. *Ambio* 19:113–122
- Baird D, Ulanowicz RE (1989) The seasonal dynamics of the Chesapeake Bay ecosystem. *Ecol Monogr* 59:329–364
- Breitburg DL (1992) Episodic hypoxia in Chesapeake Bay: interacting effects of recruitment, behavior, and physical disturbance. *Ecol Monogr* 62:525–546
- Burd BJ, Brinkhurst RO (1984) The distribution of the galatheid crab *Munidia quadrispinosa* (Benedict 1902) in relationship to oxygen concentrations in British Columbia fjords. *J Exp Mar Biol Ecol* 81:1–20
- Chao LN, Musick JA (1977) Life history, feeding habits, and functional morphology of juvenile sciaenid fishes in the York River estuary, Virginia. *Fish Bull US* 75:657–702
- Das T, Stickle WB (1993) Sensitivity of crabs *Callinectes sapidus* and *C. similis* and the gastropod *Stromonita haemastoma* to hypoxia and anoxia. *Mar Ecol Prog Ser* 98:263–274
- Das T, Stickle WB (1994) Detection and avoidance of hypoxic water by juvenile *Callinectes sapidus* and *C. similis*. *Mar Biol* 120:593–600
- Desprez M, Rybarczyk H, Wilson JG, Ducrotot JP, Sueur F, Olivesi R, Elkaim B (1992) Biological impact of eutrophication in the Bay of Somme and the induction and impact of anoxia. *Neth J Sea Res* 30:149–159
- Diaz RJ, Neubauer RJ, Schaffner LC, Pihl L, Baden SP (1992) Continuous monitoring of dissolved oxygen in an estuary experiencing periodic hypoxia and the effect of hypoxia on macrobenthos and fish. *Sci Total Environ Suppl*: 1055–1068
- Diaz RJ, Rosenberg R (1995) Marine benthic hypoxia: review of ecological effects and behavioural responses on benthic macrofauna. *Oceanogr Mar Biol Annu Rev* 33:245–303
- Diaz RJ, Schaffner LC (1990) The functional role of estuarine benthos. In: Haire M, Krome E (eds) Perspectives on the Chesapeake Bay. Chesapeake Bay Program Publ No. CBP/TRS41/90, Gloucester Point, VA, p 25–56
- Eggleston DB (1990) Behavioural mechanisms underlying variable functional responses of blue crabs, *Callinectes sapidus* feeding on juvenile oysters, *Crassostrea virginica*. *J Anim Ecol* 59:615–630
- Free CA, Beddington JR, Lawton JH (1977) On the inadequacy of simple models of mutual independence for parasitism and predation. *J Anim Ecol* 46:543–554
- Haas LW (1977) The effect of the spring-neap tidal cycle on the vertical salinity structure of the James, York, and Rappahannock Rivers, Virginia, USA. *Estuar Coast Mar Sci* 5:485–496
- Harper DE Jr, McKirney LD, Salzer RR, Case RJ (1981) The occurrence of hypoxic bottom water off the upper Texas coast and its effects on the benthic biota. *Contrib Mar Sci* 24:53–79
- Jørgensen BB (1980) Seasonal oxygen depletion in the bottom waters of a Danish fjord and its effect on the benthic community. *Oikos* 34:68–76
- Josefson AB, Widdom B (1988) Differential response of benthic macrofauna and meiofauna to hypoxia in Gullmar Fjord basin. *Mar Biol* 100:31–40
- Kolar CS, Rahel FJ (1993) Interaction of a biotic factor (predator presence) and an abiotic factor (low oxygen) as an influence on benthic invertebrate communities. *Oecologia* 95:210–219
- Kuo AY, Neilson BJ (1987) Hypoxia and salinity in Virginia estuaries. *Estuaries* 10:277–283
- Kuo AY, Park K (1993) Transport of hypoxic waters: an estuary-subestuary exchange. In: Prandle D (ed) Dynamics and exchanges in estuaries and the coastal zone. American Geophysical Union, Washington, DC, p 599–615
- Land MF, Geer PJ, Bonzek CF, Austin HM (1996) Juvenile finfish and blue crab stock assessment program York River random bottom trawl survey data summary report. Vol R1991–1994. Va Inst Mar Sci Spec Rpt No. 124. Virginia Institute of Marine Science, Gloucester Point, VA
- Llansó RJ (1992) Tolerance of low dissolved oxygen and hydrogen sulfide by the polychaete *Streblospio benedicti* (Webster). *J Exp Mar Biol Ecol* 153:165–178
- Llansó RJ (1992) Effects of hypoxia on estuarine benthos of the lower Rappahannock River (Chesapeake Bay), a case study. *Estuar Coast Mar Sci* 35:491–515
- Loesch H (1960) Sporadic mass shoreward migrations of demersal fish and crustaceans in Mobile Bay, Alabama. *Ecology* 41:292–298
- May EB (1973) Extensive oxygen depletion in Mobile Bay, Alabama. *Limnol Oceanogr* 18:353–366
- McCall JN, Fleeger JW (1993) Recognition and utilization of prey aggregations by juvenile spot (*Leiostomus xanthurus* Lacépède). *J Exp Mar Biol Ecol* 174:121–134
- Nilsson HC, Rosenberg R (1994) Hypoxic response of two marine benthic communities. *Mar Ecol Prog Ser* 115: 209–217
- Officer CB, Biggs RB, Taft JL, Cronin LE, Tyler MA, Boynton WR (1984) Chesapeake Bay anoxia: origin, development, and significance. *Science* 223:22–27
- Pavela JS, Ross JL, Chittenden ME (1983) Sharp reductions in abundance of fishes and benthic macroinvertebrates in the Gulf of Mexico off Texas associated with hypoxia. *Northeast Gulf Sci* 6:167–173
- Pearson TH, Rosenberg R (1992) Energy flow through the SE Kattegat: a comparative examination of the eutrophication of a coastal marine ecosystem. *Neth J Sea Res* 28:317–334
- Pihl L (1989) Effects of oxygen depletion on demersal fish in coastal areas of the southeast Kattegat. In: Ryland JS, Tyler PA (eds) Proc 23rd Eur Mar Biol Symp. Olsen & Olsen, Frederensborg, p 431–439
- Pihl L (1994) Changes in the diet of demersal fish due to eutrophication-induced hypoxia in the Kattegat, Sweden. *Can J Fish Aquat Sci* 51:321–336
- Pihl L, Baden SP, Diaz RJ (1991) Effects of periodic hypoxia on the distribution of demersal fish and crustaceans. *Mar Biol* 108:349–360
- Pihl L, Baden S, Diaz R, Schaffner L (1992) Hypoxia-induced structural changes in the diet of bottom feeding fish and Crustacea. *Mar Biol* 112:349–361
- Rabalais NN, Turner RE, Wiseman WJ Jr, Boesch DB (1991) A brief summary of hypoxia on the northern Gulf of Mexico continental shelf: 1985–1988. In: Tyson RV, Pearson TH (eds) Modern and ancient continental shelf anoxia. Geological Society Special Publication No. 58, The Geological Society, London, p 35–47
- Rabalais NN, Wiseman WJ Jr, Turner RE (1994) Comparison of continuous records of near-bottom dissolved oxygen from the hypoxia zone along the Louisiana coast. *Estuaries* 17:850–861
- Rainer SF, Fitzhardinge RC (1981) Benthic communities in an estuary with periodic deoxygenation. *Aust J Mar Freshwat Res* 32:227–243
- Richards FA (1965) Anoxic basins and fjords. In: Riley JP, Skirrow G (eds) Chemical oceanography. Academic Press, New York, p 611–645
- Roelofs EW (1954) Food studies of young sciaenid fishes.

- Micropogon* and *Leiostomus*, from North Carolina. *Copeia* 1954:151–153
- Rosenberg R, Loo LO, Möller P (1992) Hypoxia, salinity, and temperature as structuring factors for marine benthic communities in a eutrophic area. *Neth J Sea Res* 30:121–129
- Sandberg E (1994) Does short-term oxygen depletion affect predator-prey relationships in zoobenthos? Experiments with the isopod *Saduria entomon*. *Mar Ecol Prog Ser* 103:73–80
- Sandberg E, Bonsdorff E (1996) Effects of predation and oxygen deficiency on different age classes of the amphipod *Monoporeia affinis*. *J Sea Res* 35:345–351
- Stachowitsch M (1984) Mass mortality in the Gulf of Trieste: the course of community destruction. *PSZN I: Mar Ecol* 5:243–264
- Swanson RL, Parker CA (1988) Physical environmental factors contributing to recurring hypoxia in the New York Bight. *Trans Am Fish Soc* 117:37–47
- Tyson RV, Pearson TH (1991) Modern and ancient continental shelf anoxia: an overview. In: Tyson RV, Pearson TH (eds) *Modern and ancient continental shelf anoxia*. Geological Society Special Publication No 58, The Geological Society, London, p 1–24
- Valiela I (1995) *Marine ecological processes*, 2nd edn. Springer-Verlag, New York
- Weigelt M (1991) Short- and long-term changes in the benthic community of the deeper parts of Kiel Bay (western Baltic) due to oxygen depletion and eutrophication. *Meeresforschung* 33:197–224
- Welsh BL, Eller FC (1991) Mechanisms controlling summertime oxygen depletion in western Long Island Sound. *Estuaries* 14:265–278
- Wetzel RG (1983) *Limnology*. WB Saunders Co, Philadelphia, PA
- Whitledge TE (1985) Nationwide review of oxygen depletion and eutrophication in estuarine and coastal waters. National Oceanic and Atmospheric Administration, Informal Report, Brookhaven National Laboratory, Rockville, MD

*Editorial responsibility: William B. Stickle, Jr (Contributing Editor), Baton Rouge, Louisiana, USA*

*Submitted: June 23, 1997; Accepted: June 23, 1998  
Proofs received from author(s): September 29, 1998*